



How To Make A Home Run.™

Use And Care

G U I D E



Table of Contents	2
A Note to You	2
Important Safety Instructions	3
Parts and Features	6
Using Your Range	7
Caring for Your Range	18
If You Need Assistance or Service	25
Warranty	28
1-800-253-1301	
Call us with questions or comments.	

**STANDARD-CLEANING ELECTRIC SLIDE-IN RANGES
MODELS RS3025XB RS310PXB**

12/94

PART NO. 229C4020P024/4389350

Table of Contents

	Page		Page
A Note to You	2	Broiling tips	15
Important Safety Instructions	3	Energy saving tips	16
Parts and Features	6	The oven vent	16
Using Your Range	7	The storage drawer	17
Using the surface units	7	The anti-tip bracket	17
Positioning racks and pans	9	Caring for Your Range	18
For best air circulation	10	Surface units and reflector bowls	18
Using aluminum foil for baking	10	Lift-up cooktop	20
Setting the clock	11	Removing the oven door	21
Using the Minute Timer	11	Cleaning chart	22
Baking/roasting	12	The oven light	24
Adjusting the oven temperature control	13	If You Need Assistance or Service	25
Broiling	14	Warranty	28

A Note to You

Thank you for buying a Whirlpool® appliance.

Because your life is getting busier and more complicated, Whirlpool ranges are easy to use, save time, and help you manage your home better. To ensure that you enjoy years of trouble-free operation, we developed this Use and Care Guide. It is full of valuable information about how to operate and maintain your appliance properly and safely. Please read it carefully.

Also, please complete and mail in the Ownership Registration Card provided with your appliance. The card helps us to notify you about any new information on your appliance.

Please record your model's information.

Whenever you call our Consumer Assistance Center at 1-800-253-1301 or request service on your appliance, you need to know your complete model number and serial number. You can find this information on the model and serial number plate (see diagram on page 6 for location of plate).

Please also record the purchase date of your appliance and your dealer's name, address and telephone number.

Model Number _____

Serial Number _____

Purchase Date _____

Dealer Name _____

Dealer Address _____

Dealer Phone _____

Keep this book and the sales slip together in a safe place for future reference.

<p>Our Consumer Assistance Center number is toll-free 24 hours a day.</p>	<p>1-800-253-1301</p>
--	------------------------------

Important Safety Instructions

Your safety is important to us.

This guide contains safety statements under warning symbols. Please pay special attention to these symbols and follow any instructions given. Here is a brief explanation of the use of the symbol.

WARNING

This symbol alerts you to such dangers as personal injury, burns, fire and electrical shock.

WARNING

To reduce the risk of fire, electrical shock, injury to persons, or damage when using the range, follow basic precautions, including the following:

General

- Read all instructions before using the range.
- Install or locate the range only in accordance with the provided Installation Instructions. The range must be installed by a qualified installer. The range must be properly connected to electrical supply and grounded.

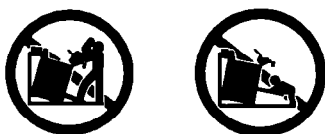

- **WARNING:** To reduce the risk of tipping of the appliance, the appliance must be secured by a properly installed anti-tip bracket. To check if the bracket is installed properly, see “The anti-tip bracket” on page 17.

- **CAUTION:** Do not store things children might want above the range. Children could be burned or injured while climbing on it.
- Do not leave children alone or unattended in area where the range is in use. They should never be allowed to sit or stand on any part of the range. They could be burned or injured.
- Do not operate the range if it is damaged or not working properly.
- Do not use the range for warming or heating the room. Persons could be burned or injured, or a fire could start.
- Use the range only for its intended use as described in this manual.

continued on next page

IMPORTANT SAFETY INSTRUCTIONS



- Do not touch surface units, areas near units, heating elements or interior surfaces of oven. Surface units and heating elements may be hot even though they are dark in color. Areas near surface units and interior surfaces of an oven become hot enough to cause burns. During and after use, do not touch, or let clothing or other flammable materials contact surface units, areas near units, heating elements or interior surfaces of oven until they have had sufficient time to cool. Other surfaces of the range, such as the oven vent opening, the surface near the vent opening, the cooktop, and the oven door, could also become hot enough to cause burns.



- Do not wear loose or hanging garments when using the range. They could ignite if they touch a hot surface unit and you could be burned.
- Use only dry potholders. Moist or damp potholders on hot surfaces could result in burns from steam. Do not let potholder touch hot heating elements. Do not use a towel

or bulky cloth for a potholder. It could catch on fire.

- Keep range vents unobstructed.
- Do not heat unopened containers. They could explode. The hot contents could cause burns and container particles could cause injury.
- Do not store flammable materials on or near the range. The fumes could create an explosion and/or fire hazard.

When using the cooktop

- Make sure the reflector bowls are in place during cooking. Cooking without reflector bowls could subject the wiring and components underneath them to damage.
- Do not line reflector bowls with aluminum foil or other liners. Improper installation of these liners could result in a risk of electric shock or fire.
- Select a pan with a flat bottom that is about the same size as the surface unit. If pan is smaller than the surface unit, some of the heating element will be exposed and could result in the igniting of clothing or potholders. Correct pan size also improves cooking efficiency.
- Check to be sure glass cooking utensils are safe for use on the range. Only certain types of glass, glass-ceramic, ceramic, earthenware or other glazed utensils are suitable for cooktops without breaking due to the sudden change in temperature.

IMPORTANT SAFETY INSTRUCTIONS

- Never leave surface units unattended at high heat settings. A boilover could result and cause smoking and greasy spillovers that could ignite.



- Turn pan handles inward, but not over other surface units. This will help reduce the chance of burns, igniting of flammable materials, and spills due to bumping of the pan.

When using the oven

- Always position oven rack(s) in desired location while oven is cool. If a rack must be removed while oven is hot, do not let potholder contact hot heating element in oven.
- Use care when opening oven door. Let hot air or steam escape before removing or replacing food.

Grease

- Grease is flammable. Do not allow grease to collect around cooktop or in vents. Wipe spills immediately.



- Do not use water on grease fires. Never pick up a flaming pan. Smother flaming pan on range by covering with a well-fitted lid, cookie sheet or flat tray. Flaming grease outside of pan can be extinguished with baking soda or, if available, a multipurpose dry chemical or foam-type extinguisher.

Care and cleaning

- Do not soak removable heating elements in water. The element will be damaged and shock or fire could result.
- Do not clean door heat seal. It is essential for a good seal. Care should be taken not to rub, damage or move the seal. Clean only parts recommended in this Use and Care Guide.
- Do not repair or replace any part of the range unless specifically recommended in this manual. All other servicing should be referred to a qualified technician.
- Disconnect the electrical supply before servicing the range.

– SAVE THESE INSTRUCTIONS –

Parts and Features

This section contains captioned illustrations of your range. Use them to become familiar with the location and appearance of all parts and features.

(Model RS310PXB shown)

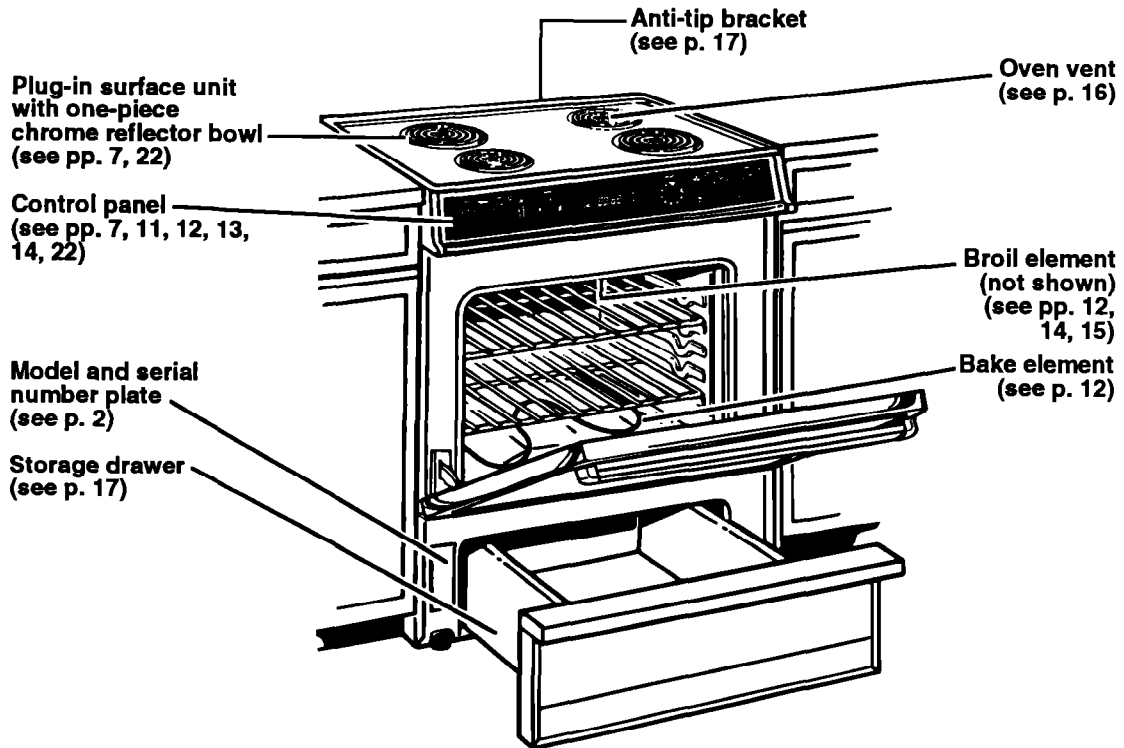

Control panel

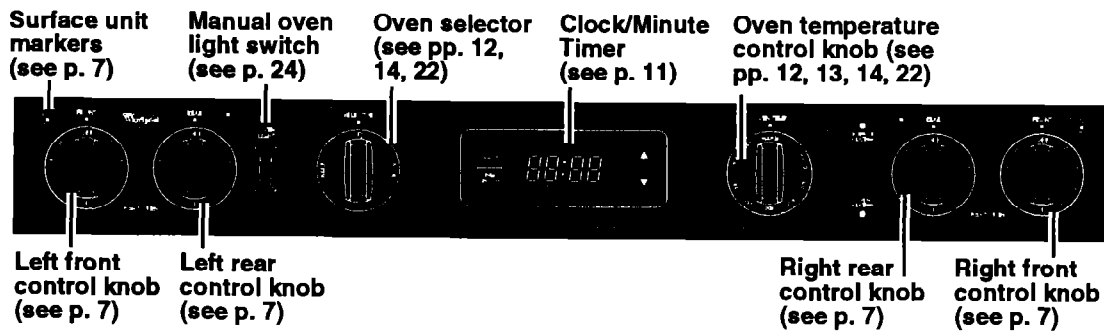

Using Your Range

To obtain the best cooking results possible, you must operate your range properly. This section gives you important information for efficient and safe use of your range.

Using the surface units

Push in control knobs before turning them to a setting. You can set them anywhere between HI and OFF.

Surface unit markers

The solid dot in the surface unit marker shows which surface unit is turned on by that knob.

Surface heating indicator light

The SURFACE HEATING Indicator Light on the control panel will glow when a surface unit is turned on.

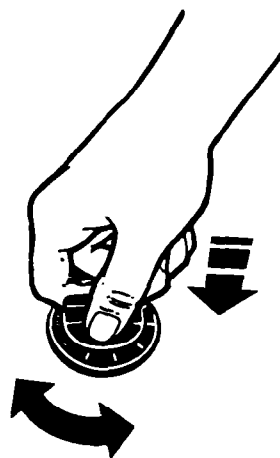

⚠ WARNING

Burn and Fire Hazard

Be sure all control knobs are turned to OFF and all indicator lights are OFF when you are not cooking.

Someone could be burned or a fire could start if a surface unit is accidentally left ON.

Until you get used to the settings, use the following as a guide. For best results, start cooking at the high setting; then turn the control knob down to continue cooking.

SETTING	RECOMMENDED USE
HI	<ul style="list-style-type: none">•To start foods cooking.•To bring liquids to boil.
Medium-high	<ul style="list-style-type: none">•To hold a rapid boil.•To fry chicken or pancakes.
Medium (opposite OFF)	<ul style="list-style-type: none">•For gravy, pudding and icing.•To cook large amounts of vegetables.
Medium-low	<ul style="list-style-type: none">•To keep food cooking after starting it on a higher setting.
LO	<ul style="list-style-type: none">•To keep food warm until ready to serve.

USING YOUR RANGE

Cookware tips

- **Select a pan** that is about the same size as the surface unit.
- **NOTE: For best results and greater energy efficiency**, use only flat-bottomed cookware that makes good contact with the surface units. Cookware with rounded, warped, ribbed (such as some porcelain enamelware) or dented bottoms could cause severe overheating, which damages the cookware and/or surface unit.

You can, however, use the newer cookware available with slightly indented bottoms or very small expansion channels. This cookware is specially designed to provide the good contact needed for best cooking results.

Also, woks, canners and teakettles with flat bottoms suitable for use on your cooktop are now available in most stores that sell housewares.

- **The pan** should have straight sides and a tight-fitting lid.
- **Choose medium to heavy gauge** (thickness) pans that are fairly lightweight.
- **The pan material** (metal or glass) affects how fast heat transfers from the surface unit through the pan material and how evenly heat spreads over the pan bottom. Choose pans that provide the best cooking results.
- **Handles** should be made of sturdy, heat-resistant material and be securely attached to the pan.

Home canning information

The large diameter of most water-bath or pressure canners combined with high heat settings for long periods of time can shorten the life of regular surface units and cause damage to the cooktop.

To protect your range:

- **Use flat-bottomed canners/pans** for best results.
- **Use the largest surface unit** for best results. Also, use a canner/pan which can be centered over the surface unit and which does not extend more than one inch outside surface unit area. Large diameter canners/pans, if not properly centered, trap heat and can cause damage to the cooktop.
- **Do not place canner** on two surface units at the same time. Too much heat will build up and will damage the cooktop.
- **Start with hot water.** This reduces the time the control is set on high. Reduce heat setting to lowest position needed to keep water boiling.
- **Keep reflector bowls clean** for best heat reflection.
- To prolong the life of the elements:
 - **Prepare small batches** at a time.
 - **Do not use elements** for canning all day.
- **Refer** to your canner manual for specific instructions.

⚠ CAUTION

Product Damage Hazard

- If a surface unit stays red for a long time, the bottom of the pan is not flat enough or is too small for the surface unit. Prolonged usage of incorrect utensils for long periods of time could result in damage to the surface unit, cooktop, wiring and surrounding areas. To prevent damage, use correct utensils, start cooking on HI and turn control down to continue cooking.
- Do not leave an empty utensil, or one which has boiled dry, on a hot surface unit. The utensil could overheat and could damage the utensil or surface unit.

Positioning racks and pans

For baking/roasting with one rack, place the rack so the top of the food will be centered in the oven.

Rack placement for specific foods:

FOOD	RACK POSITION
Frozen pies, large roasts, turkeys	Lowest level or 2nd level from bottom
Angel and bundt cakes, most quick breads, yeast breads, casseroles, meats	2nd level from bottom
Cookies, biscuits, muffins, cakes, nonfrozen pies	2nd or 3rd level from bottom

When baking on two racks, arrange racks on bottom and third level from bottom.

NOTE: For recommended rack placement when broiling, see “Broiling rack position chart” on page 15.

To remove racks:

1. Pull rack toward you.
2. Tilt up front end.
3. Pull rack out.

To replace racks:

1. Place rack on rack guides.
2. Tilt up front end.
3. Push rack in until it clears the stop.
4. Lower front and push rack in the rest of the way.

WARNING

Personal Injury Hazard

- Always position oven rack(s) in desired location before turning oven on. Be sure the rack(s) is level.
- If rack(s) must be moved while oven is hot, use potholders or oven mitts to protect hands.

Failure to follow the above precautions could result in personal injury.

For best air circulation

Hot air must circulate around the pans in the oven for even heat to reach all parts of the oven. This results in better baking.

- **Place** the pans so that one is not directly over the other.
- **For best results, allow** 1½ to 2 inches (4.5 cm) of space around each pan and between pans and oven walls. There must be a minimum space of 1 inch (2.5 cm).
- **Use** only one cookie sheet in the oven at one time.

Use the following as a guide to determine where to place the pans:

One pan

Place in the center of the oven rack.

Two pans

Place in opposite corners of the oven rack.

Three or four pans

Place in opposite corners on each oven rack. Stagger pans so no pan is directly over another.

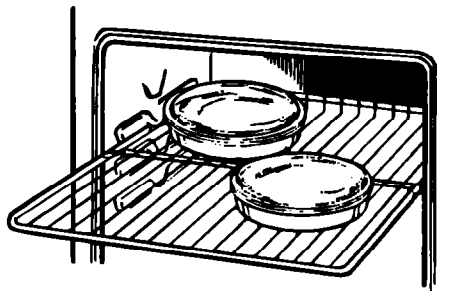

Using aluminum foil for baking

Use aluminum foil to catch spillovers from pies or casseroles:

- **Place** the foil on the oven rack below the rack with the food. **Turn up** foil edges and **make sure** foil is about 1 inch (3 cm) larger all around than the dish holding the food.
- **Do not cover** the entire rack with aluminum foil. It will reduce air circulation and cause poor cooking results.
- **Do not line** oven bottom or entire oven rack with foil or other liners. Poor baking will result.

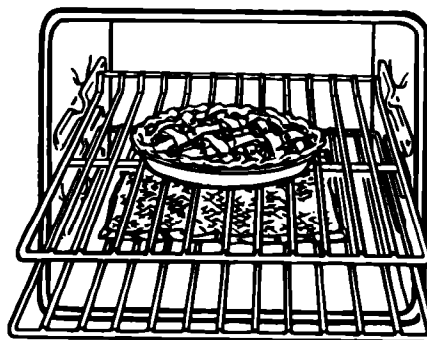

⚠ WARNING

Electrical Shock and Fire Hazard

Do not allow foil to touch the heating elements.

Failure to follow this precaution could result in electrical shock or fire hazard and damage to the elements.

Setting the clock

1. **Press** the Clock pad.



CLOCK

2. **Press** the Increase or Decrease pad until the correct time is displayed.



Using the Minute Timer

The Minute Timer does not start or stop the oven. It works like a kitchen timer. It can be set in hours and minutes up to 9 hours, 55 minutes. You can use the Minute Timer during any cooking function.

1. **Press** the Timer On/Off pad.



TIMER
ON/OFF

2. **Press** the Increase or Decrease pad until the desired time (in hours and minutes) is displayed.



To cancel the Minute Timer:

- **When TIMER is on the Display**, press the Timer On/Off pad. The time of day will show on the Display.



TIMER
ON/OFF

Baking/roasting

1. **Position** the rack(s) properly **before** turning on the oven. For further information see "Positioning racks and pans" on page 9.

2. **Set** the Oven Selector to **BAKE**.

3. **Set** the Oven Temperature Control Knob to the baking/roasting temperature you want. The **OVEN HEATING** Indicator Light will come on. The oven is preheated when the **OVEN HEATING** Indicator Light first goes off.

NOTE: Do not preheat oven when roasting or cooking items such as casseroles.

4. **Put** food in the oven. During baking/roasting, the elements will turn on and off to maintain the temperature setting. The **OVEN HEATING** Indicator Light will turn on and off with the elements.

NOTE: The top element helps heat during baking/roasting, but does not turn red.

5. **When** baking/roasting is done, turn the Oven Selector to **OFF**. The **OVEN HEATING** Indicator Light will go off.

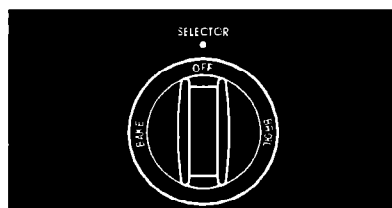
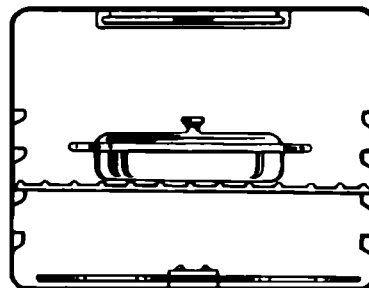
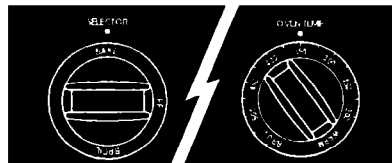

Adjusting the oven temperature control

Oven temperature controls will gradually shift after years of use. So, even though your new oven is properly adjusted to provide accurate temperatures, it may cook faster or slower than your old oven.

If, after using the oven for a period of time, you are not satisfied with the temperature settings, you can change them by following these steps:

1. **Make sure** the Oven Temperature Control Knob is turned to the off position. **Pull knob straight off and flip it over.**

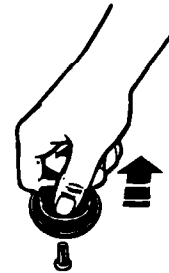

2. **Loosen the locking screws inside the control knob. Note the position of the notches.**
3. **To lower the temperature, hold knob handle firmly and move the tooth a notch counterclockwise.** Each notch equals about 5°F (2.5°C).
4. **To raise the temperature, hold knob handle firmly and move the tooth a notch clockwise.** Each notch equals about 5°F (2.5°C).
5. **Tighten the locking screws and replace the control knob.**

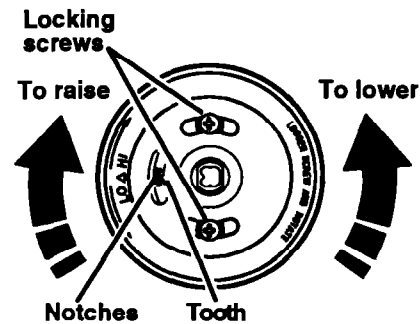

Broiling

1. **Position** the rack properly **before** turning on the oven. The oven rack should be positioned so that the surface of the food is at least 3 inches (7 cm) away from the broil element. See "Broiling rack position chart" on page 15.
2. **Put** the broiler pan and food on the rack.
3. **Close** the door to the Broil Stop position (open about 4 inches [10 cm]). The door will stay open by itself.
4. **Set** the Oven Selector and Oven Temperature Control Knob to BROIL. The OVEN HEATING Indicator Light will come on.

NOTE: Do not preheat oven when broiling.

5. **When broiling is done**, turn the Oven Selector to OFF. The OVEN HEATING Indicator Light will go off.

Custom broil

- If food is cooking too fast, turn the Oven Temperature Control Knob **counterclockwise** until the OVEN HEATING Indicator Light goes off.
- If you want the food to broil slower from the start, **set** the Oven Temperature Control Knob between 170°F and 325°F (77°C and 163°C). These temperature settings allow the broil heating element to cycle and to slow cooking. The lower the temperature, the slower the cooking.
- **Fish and chicken** are some foods that may cook better if you use lower broiling temperatures.

The Oven Selector must be on BROIL for all broiling temperatures.

NOTE: Leave the oven door partly open whenever using the oven to broil. This allows the oven to maintain proper temperatures.

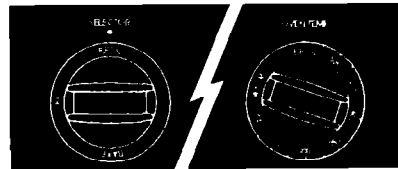

Broiling rack position chart

RACK POSITION FROM BOTTOM	TYPE OF FOOD/ DONENESS
4	Hamburger patties and thin steaks, ½" thick or less
3	Quickly searing food, rare and medium steaks, medium patties, ham slices, fish steaks, frankfurters
2	Well-done steaks and patties, lamb chops, split chicken, pork steaks and chops, whole fish
1	Not used for broiling

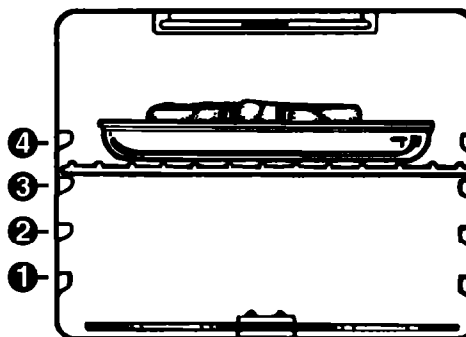

Broiling tips

- **Use** the broiler pan and grid for broiling. They are designed to drain excess liquid and grease away from the cooking surface to help prevent spatter, smoke or fire.
- **After broiling, remove** the broiler pan from the oven when you remove the food. Drippings will bake on the pan if you leave it in the heated oven.

⚠ WARNING

Fire Hazard

- Place meat the correct distance from the element. Meat placed too close to the element could spatter, smoke, burn or catch fire during broiling.
- To ensure adequate grease drainage, do not use cookie sheets or similar pans for broiling. Also, covering the broiler grid with foil is not recommended. Poor drainage of grease could result in fire. If foil is used, cut slits in foil to line up with all openings in broiler grid. Grease can then drain away and cool in pan.

Energy saving tips

Although the energy used for cooking is usually a very small percentage of the total energy used in the home, cooking energy can be used efficiently. Here are some tips to help you save energy when using your cooking product:

- **Use** pans with flat bottoms, straight sides and tight-fitting lids.
- **Match** the pan to the surface unit size.
- **Cook** with a minimum of liquid or grease to help shorten cooking time.
- **Preheat** pans only when recommended and for the shortest time possible.
- **Start** food on higher heat settings, then set surface unit control on low or off to finish cooking. Use retained heat for cooking when possible.
- **Use** the more efficient surface units instead of the oven when possible.
- **Turn on** the surface unit only after placing filled pan on the unit.
- **“Oven peeking”** may cause heat loss, longer cooking times and unsatisfactory baking results. Rely on your timer to keep track of the cooking time.
- **Bake** cakes, pies or cookies when oven is warm. Best time to bake is right after a meal has been cooked in the oven.
- **Preheat** the oven no longer than necessary.
- **Plan** your meals for the most efficient use of the range. When using the oven to cook one food, try to cook the rest of the meal in it also.
- **Do not preheat** when broiling, roasting or cooking items such as casseroles.
- **Keep** reflector bowls clean for best heat reflection.

The oven vent

Hot air and moisture escape from the oven through a vent under the right rear surface unit. You can cook on the unit or keep food warm on it while the oven is on. The vent is needed for air circulation. **Do not block the vent.** Poor baking/roasting can result.

NOTE: Plastic utensils left over the vent can melt.

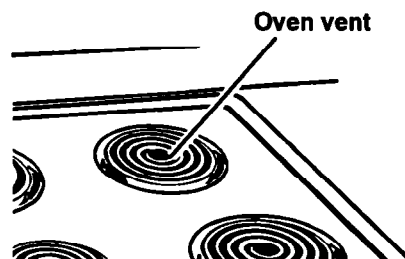

⚠ WARNING

Burn and Fire Hazard

- If you leave a utensil on the right rear surface unit, use potholders when moving it. Pan handles could become hot enough to burn.
- Keep flammable materials away from oven vent. Failure to do so could result in burns or a fire.

The storage drawer

You can remove the storage drawer to make it easier to clean under the range.

Use care when handling the drawer.

Removing the storage drawer:

1. **Empty** drawer before removing. **Pull** drawer straight out to the first stop. **Lift** front and **pull out** to the second stop.
2. **Lift** back slightly and **slide** drawer all the way out.

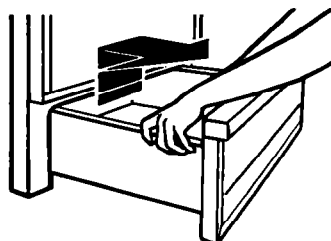

Replacing the storage drawer:

1. **Fit** ends of drawer slide rails into the drawer guides on both sides of opening.
2. **Lift** drawer front and **push in** until metal stops on drawer slide rails clear white stops on drawer guides. **Lift** drawer front again to clear second stop and **slide** drawer closed.

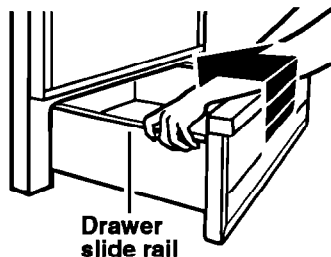

Drawer slide rail

The anti-tip bracket

The range will not tip during normal use. However, tipping can occur if you apply too much force or weight to the open door without the anti-tip bracket properly secured.



⚠ WARNING

Personal Injury Hazard

- To reduce risk of range tipping over, secure range with a properly installed anti-tip bracket supplied with range.
- If range is moved for cleaning or service, check that anti-tip device is engaged before using range.

Failure to follow the above precautions could result in personal injury.

To verify the anti-tip bracket is engaged:

- **Grasp** rear of range and carefully try to tilt forward. If anti-tip bracket is attached to floor or wall correctly, range should not tilt forward.
- **See** Installation Instructions for further details.

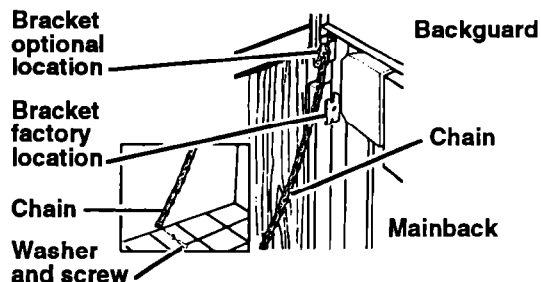

Caring for Your Range

Your range is designed for easy care. You can do most cleaning with items found around your home. Cleaning your range whenever spills or soiling occurs will help to keep it looking and operating like new.

⚠ WARNING

Burn and Electrical Shock Hazard
Make sure all controls are OFF and the range is cool before cleaning.
Failure to do so could result in burns or electrical shock.

Surface units and reflector bowls

Removing

1. **Make sure** all surface units are off and cool before removing surface units and reflector bowls.

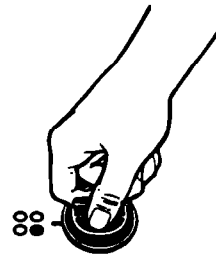

2. **Lift** the edge of the unit, opposite the receptacle, just enough to clear the reflector bowl.

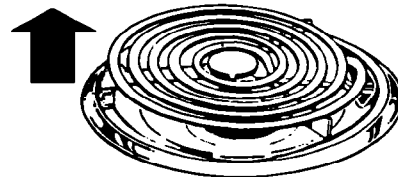

3. **Pull** the surface unit straight away from the receptacle.

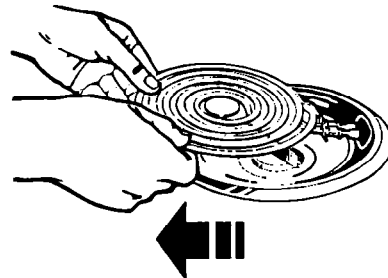

4. **Lift out** the reflector bowl. **See** "Cleaning chart" on page 22 for cleaning instructions.

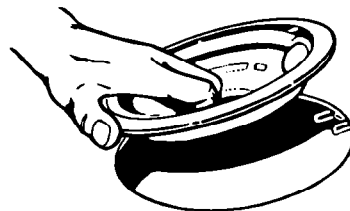

Replacing

1. **Make sure** all surface units are off and cool before replacing surface units and reflector bowls.

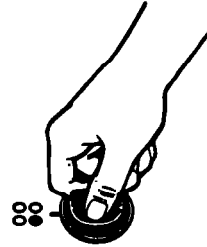

2. **Line up** openings in the reflector bowl with the surface unit receptacle.

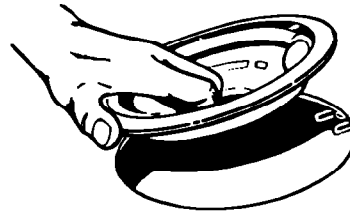

3. **Hold** the surface unit as level as possible with the terminal just started into the receptacle. **Push** the surface unit terminal into the receptacle.

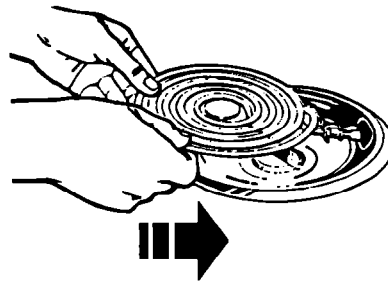

4. When terminal is pushed into the receptacle as far as it will go, **push down** the edge of the surface unit opposite the receptacle.

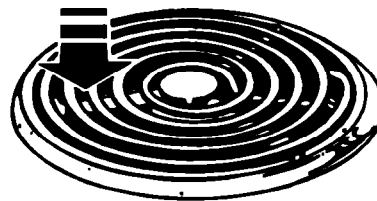

NOTE: Reflector bowls reflect heat back to the utensils on the surface units. They also help catch spills. When they are kept clean, they reflect heat better and look new longer.

If a reflector bowl gets discolored, some of your utensils may not be flat enough, or some may be too large for the surface unit. In either case, some of the heat that's meant to go into or around a utensil goes down and heats the reflector bowl. This extra heat can discolor it.

Lift-up cooktop

1. **Lift** front of cooktop at both front corners until the support locks into place.

⚠ WARNING

Personal Injury Hazard

Be sure support is fully extended and in the locked position.

Failure to do so could result in personal injury from the cooktop accidentally falling.

Product Damage Hazard

Do not drop the cooktop. Damage could result to the porcelain and the cooktop frame.

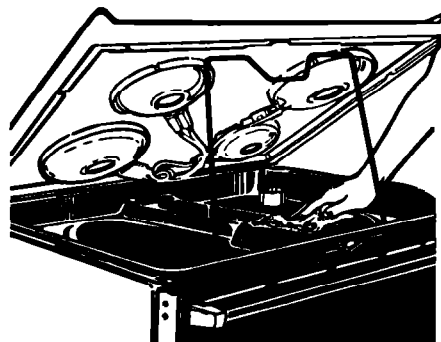

2. **Wipe** with warm, soapy water. **Use** a soapy steel-wool pad on heavily soiled areas.
3. **To lower the cooktop, lift** cooktop from both sides while pressing the support back to unlock it. **Lower** the cooktop into place.

Removing the oven door

Removing the oven door will help make it easier to clean the oven.

⚠ WARNING

Burn and Electrical Shock Hazard

Make sure all controls are OFF and the oven is cool before removing oven door.

Failure to do so could result in burns or electrical shock.

1. **Open** the door to the first stop position.
2. **Hold** the door at both sides and **lift it at the same angle it is in.**

NOTE: Be careful not to place hands between the spring hinge and the oven frame as the spring hinge could snap back and pinch your fingers or damage the porcelain on the front of the range. Cover the hinges with toweling or empty paper towel rolls while working in the oven area.

3. **To replace, fit** the bottom corners of the door over the ends of the hinges. **Push** the door down evenly. The door will close only when it is on the hinges correctly. If hinges snap back against the oven frame, pull them back out.

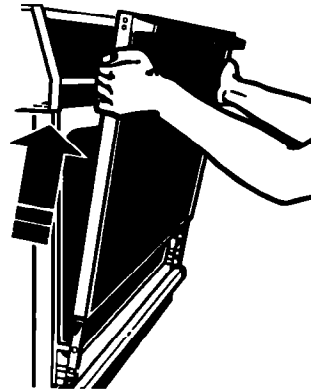

Cleaning chart

Use the following table to help you clean all parts of your range.

PART	WHAT TO USE	HOW TO CLEAN
Control knobs	Sponge and warm, soapy water	<ul style="list-style-type: none"> • Turn knobs to OFF and pull straight away from control panel. • Wash, rinse and dry thoroughly. Do not soak. • Do not use steel wool or abrasive cleansers. They may damage the finish of the knobs. • Replace knobs. Make sure all knobs point to OFF.
Control panel	Sponge and warm, soapy water OR Paper towel and spray glass cleaner	<ul style="list-style-type: none"> • Wash, rinse and dry thoroughly. • Do not use steel wool or abrasive cleansers. They may damage the finish. • Do not spray cleaner directly on panel. Apply cleaner to paper towel.
Exterior surfaces (other than control panels)	Sponge and warm, soapy water	<ul style="list-style-type: none"> • Wash, rinse and dry thoroughly. • Use nonabrasive, plastic scrubbing pad on heavily soiled areas. • Do not use abrasive or harsh cleansers. They may damage the finish. • On brushed chrome cooktop, dry the surface following the "grain." To help prevent finger marks after cleaning, spread a thin film of baby oil on the surface. Wipe away excess oil with a clean, soft cloth. <p>NOTE: Do not allow foods containing acids (such as vinegar, tomato or lemon juice) to remain on surface. Acids may remove the glossy finish. Also wipe up milk or egg spills when cooktop is cool.</p>
Surface units	No cleaning required	<ul style="list-style-type: none"> • Spatters or spills will burn off. • Do not immerse in water.
Chrome reflector bowls	Warm, soapy water and a nonabrasive, plastic scrubbing pad	<ul style="list-style-type: none"> • Wash, rinse and dry thoroughly. • Clean frequently. • Do not use abrasive or harsh cleansers.

CARING FOR YOUR RANGE

PART	WHAT TO USE	HOW TO CLEAN
Broiler pan and grid (clean after each use)	Steel-wool pad and warm, soapy water	<ul style="list-style-type: none"> • Wash, rinse and dry thoroughly.
Oven racks	Steel-wool pad and warm, soapy water	<ul style="list-style-type: none"> • Wash, rinse and dry thoroughly.
Oven door glass	Paper towel and spray glass cleaner OR Warm, soapy water and a nonabrasive, plastic scrubbing pad	<ul style="list-style-type: none"> • Make sure oven is cool. • Follow directions provided with the cleaner. • Wash, rinse and dry thoroughly.
Oven cavity	Steel-wool pad and warm, soapy water OR Commercial oven cleaners Heavy-duty aluminum foil or shallow pan	<ul style="list-style-type: none"> • Make sure oven is cool. • Remove door for easier access. (See page 21.) • Clean heavily soiled areas or stains. Rinse well with water. • Remove door for easier access. • Place newspaper on floor to protect floor surface. • Follow directions provided with the oven cleaner. • Rinse well with clear water. • Use in well-ventilated room. • Do not allow commercial oven cleaners to contact the heating elements, heat seal, thermostat or exterior surfaces of the range. Damage will occur. • Place piece of foil or shallow pan, slightly larger than the cooking container, on lower rack to catch spillovers. <p>NOTE: Do not use foil or foil liner to cover the oven floor. Poor baking/roasting results could occur.</p>

The oven light

To turn the light on, use the Oven Light Switch on the control panel.

⚠ WARNING

Electrical Shock and Burn Hazard

Make sure oven and light bulb are cool and power to the range has been turned OFF before replacing the light bulb.

Failure to do so could result in electrical shock or burns.

To replace the oven light:

1. **Unplug** appliance or **disconnect** at main power supply.
2. **Remove** the light bulb from its socket. **Replace** the bulb with a 40-watt appliance bulb.
3. **Plug in** appliance or **reconnect** at the main power supply.

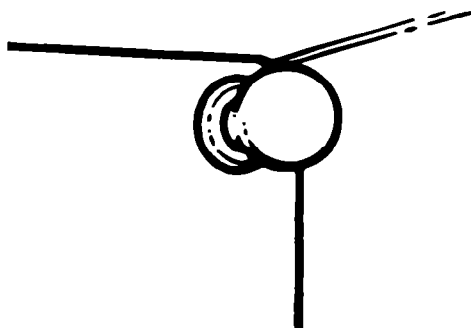

If You Need Assistance or Service

This section is designed to help you save the cost of a service call. Part 1 of this section outlines possible problems, their causes, and actions you can take to solve each problem. Parts 2 and 3 tell you what to do if you still need assistance or service. When calling our Consumer Assistance Center for help or calling for service, please provide a detailed description of the problem, your appliance's complete model and serial numbers and the purchase date. (See page 2.) This information will help us respond properly to your request.

1. Before calling for assistance ...

Performance problems often result from little things you can find and fix without tools of any kind. Please check the chart below for problems you can fix. It could save you the cost of a service call.

PROBLEM	POSSIBLE CAUSE	SOLUTION
Nothing will operate	The unit is not wired into a live circuit with proper voltage. A household fuse has blown or a circuit breaker has tripped.	Wire the unit into a live circuit with proper voltage. (See Installation Instructions.) Replace household fuse or reset circuit breaker.
The oven will not operate	You have not turned the Oven Selector to BAKE or BROIL. You have not turned the Oven Temperature Control Knob to a temperature setting.	Turn the Oven Selector to the desired setting. Turn the Oven Temperature Control Knob to a temperature setting.
The surface units will not operate	A household fuse has blown or a circuit breaker has tripped. You have not plugged in surface units all the way. You are not setting the control knobs correctly.	Replace household fuse or reset circuit breaker. Turn control knobs to OFF and plug in surface units all the way. (See "Replacing" on page 19.) Push control knobs in before turning to a setting.
Control knob(s) will not turn	You are not pushing in before turning.	Push control knob(s) in before turning to a setting.

continued on next page

IF YOU NEED ASSISTANCE OR SERVICE

PROBLEM	POSSIBLE CAUSE	SOLUTION
<p>Cooking results are not what you expected</p>	<p>The range is not level.</p> <p>The oven temperature seems too low or too high.</p> <p>You have not preheated the oven as the recipe calls for.</p> <p>The recipe has never been tested or is not from a reliable source.</p> <p>The pans are not the type or size recommended in the recipe.</p> <p>There is not proper air circulation around pan when baking.</p> <p>The cooking utensils are not the proper shape or do not fit the surface units being used.</p>	<p>Level range. (See Installation Instructions.)</p> <p>Adjust the oven temperature control. (See "Adjusting the oven temperature control" on page 13.)</p> <p>Preheat oven if called for in recipe.</p> <p>Use only tested recipes from a reliable source.</p> <p>Refer to a reliable cookbook for recommended pan type and size.</p> <p>Allow 1½ to 2 inches (4-5 cm) on all sides of the pans for air circulation. There must be a minimum space of 1 inch (2.5 cm).</p> <p>Use cooking utensils with smooth, flat bottoms that fit the surface units being used.</p>

2. If you need assistance ...

Call Whirlpool Consumer Assistance Center telephone number. Dial toll-free from anywhere in the U.S.A.:

1-800-253-1301

and talk with one of our trained consultants. The consultant can instruct you in how to obtain satisfactory operation from your appliance or, if service is necessary, recommend a qualified service company in your area.

If you prefer, write to:

Mr. William Clark
Consumer Assistance Representative
Whirlpool Corporation
2000 N State Route 63
Benton Harbor, MI 49022-2692

Please include a daytime phone number in your correspondence.

3. If you need service ...



Whirlpool has a nationwide network of authorized Whirlpool® service companies. Whirlpool service technicians are trained to fulfill the product warranty and provide after-warranty service, anywhere in the United States. To locate the authorized Whirlpool service company in your area, call our Consumer Assistance Center telephone number (see Step 2) or look in your telephone directory Yellow Pages under:

**• APPLIANCE-HOUSEHOLD-
MAJOR, SERVICE & REPAIR**
- See: Whirlpool Appliances or
Authorized Whirlpool Service
(Example: XYZ Service Co.)

**• WASHING MACHINES &
DRYERS, SERVICE & REPAIR**
- See: Whirlpool Appliances or
Authorized Whirlpool Service
(Example: XYZ Service Co.)

4. If you need FSP® replacement parts ...

FSP is a registered trademark of Whirlpool Corporation for quality parts. Look for this symbol of quality whenever you need a replacement part for your Whirlpool® appliance. FSP replacement parts will fit right and work right, because they are made to the same exacting specifications used to build every new Whirlpool appliance.

To locate FSP replacement parts in your area, refer to Step 3 above or call the Whirlpool Consumer Assistance Center number in Step 2.

5. If you are not satisfied with how the problem was solved ...

- Contact the Major Appliance Consumer Action Panel (MACAP). MACAP is a group of independent consumer experts that voices consumer views at the highest levels of the major appliance industry.
- Contact MACAP only when the dealer, authorized servicer and Whirlpool have failed to resolve your problem.
Major Appliance Consumer Action Panel
20 North Wacker Drive
Chicago, IL 60606
- MACAP will in turn inform us of your action.

WHIRLPOOL®

Electric Range Warranty

LENGTH OF WARRANTY	WHIRLPOOL WILL PAY FOR
FULL ONE-YEAR WARRANTY From Date of Purchase	FSP® replacement parts and repair labor to correct defects in materials or workmanship. Service must be provided by an authorized Whirlpool service company.
LIMITED WARRANTY FOR LIFE OF THE PRODUCT Second Year Through Life of Product From Date of Purchase	FSP replacement parts for control knobs.
WHIRLPOOL WILL NOT PAY FOR	
<p>A. Service calls to:</p> <ol style="list-style-type: none"> 1. Correct the installation of your range. 2. Instruct you how to use your range. 3. Replace house fuses or correct house wiring. 4. Replace owner accessible light bulbs. <p>B. Repairs when your range is used in other than normal, single-family household use.</p> <p>C. Pickup and delivery. Your range is designed to be repaired in the home.</p> <p>D. Damage to your range caused by accident, misuse, fire, flood, acts of God or use of products not approved by Whirlpool.</p> <p>E. Any labor costs during limited warranty.</p> <p>F. Repairs to parts or systems caused by unauthorized modifications made to the appliance.</p>	

5/93

WHIRLPOOL CORPORATION SHALL NOT BE LIABLE FOR INCIDENTAL OR CONSEQUENTIAL DAMAGES. Some states do not allow the exclusion or limitation of incidental or consequential damages, so this limitation or exclusion may not apply to you. This warranty gives you specific legal rights, and you may also have other rights which vary from state to state.

Outside the United States, a different warranty may apply. For details, please contact your authorized Whirlpool distributor or military exchange.

If you need service, first see the "If You Need Assistance or Service" section of this book. After checking "If You Need Assistance or Service" additional help can be found by calling our Consumer Assistance Center telephone number, **1-800-253-1301**, from anywhere in the U.S.A.



Printed on recycled paper—
 10% post-consumer waste
 50% recovered materials

PART NO. 229C4020P024/4389350

© 1994 Whirlpool Corporation

● Registered Trademark/TM Trademark of Whirlpool, U.S.A.

Printed in U.S.A.