

## OVEN CIRCUIT // CIRCUIT DU FOUR

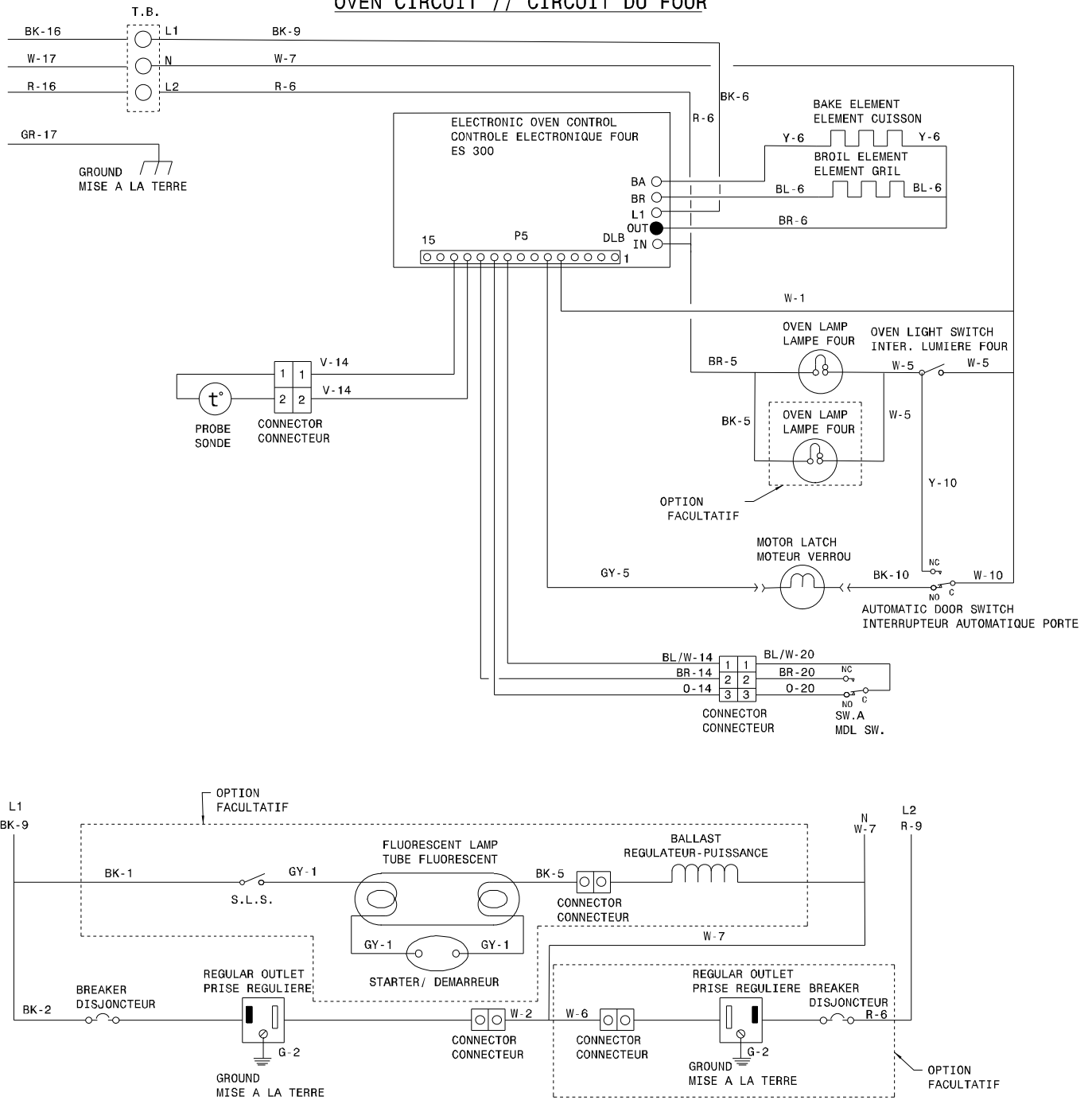

### LEGEND/LEGENDE

SW. - SWITCH/INTERRUPTEUR  
 R.F. - RIGHT FRONT/AVANT DROIT  
 R.R. - RIGHT REAR/ARRIERE DROIT  
 L.F. - LEFT FRONT/AVANT GAUCHE  
 L.R. - LEFT REAR/ARRIERE GAUCHE  
 P.L. - PILOT LIGHT/LAMPE TEMOIN  
 LIM. - LIMITOR/LIMITEUR  
 W.Z. - WARMER ZONE/ZONE RECHAUD  
 UIB. - UNIT INTERFACE BOARD/PLAQUETTE INTERFACE  
 H.S. - HOT SURFACE/SURFACE CHAUDE  
 T.B. - TERMINAL BLOCK/BLOC DE CONNECTION  
 MDL. - MOTOR DOOR LATCH/MOTEUR PORTE VERROU  
 S.L.S. - SURFACE LAMP SWITCH/INTERRUPTEUR LAMPE-SURFACE

### COLOR CODE/CODE DE COULEUR

G. - GREEN/VERT  
 W. - WHITE/BLANC  
 R. - RED/ROUGE  
 O. - ORANGE/ORANGE  
 Y. - YELLOW/JAUNE  
 BR. - BROWN/BRUN  
 BL. - BLUE/BLEU  
 BK. - BLACK/NOIR

| WIRE FIL | GAUGE CALIBRE | TEMP. °C | CSA     | UL   |
|----------|---------------|----------|---------|------|
| 1        | 18            | 125      | CL1251  | 3173 |
| 2        | 16            | 125      | CL1251  | 3173 |
| 3        | 14            | 125      | CL1251  | 3173 |
| 4        | 12            | 125      | CL1251  | 3173 |
| 5        | 18            | 150      | EXL-150 | 3321 |
| 6        | 16            | 150      | EXL-150 | 3321 |
| 7        | 14            | 150      | EXL-150 | 3321 |
| 8        | 12            | 150      | EXL-150 | 3321 |
| 9        | 10            | 150      | EXL-150 | 3321 |
| 10       | 18            | 200      | SEW-1   | 3122 |
| 11       | 16            | 200      | SEW-1   | 3122 |
| 12       | 12            | 250      |         | 3252 |
| 13       | 16            | 250      |         | 3252 |
| 14       | 20            | 150      | EXL-150 | 3321 |
| 15       | 8             | 150      | EXL-150 | 3321 |

| WIRE FIL | GAUGE CALIBRE | TEMP. °C | CSA     | UL   |
|----------|---------------|----------|---------|------|
| 16       | 8             | 60       |         |      |
| 17       | 10            | 60       |         |      |
| 18       | 10            | 200      | SEW-1   | 3122 |
| 19       | 20            | 125      | SEW-1   | 3173 |
| 20       | 20            | 200      | SEW-1   | 3122 |
| 21       | 22            | 125      | CL-1252 | 3266 |

**CAUTION: DISCONNECT POWER BEFORE SERVICING UNIT.**  
**ATTENTION: COUPEZ L'ALIMENTATION AVANT D'EFFECTUER LA REPARATION.**

**318046791 REV:A**  
**SHEET/FEUILLE: 1/2**

COOKTOP CIRCUIT // CIRCUIT TABLE CUISSON

SURFACE-ELEMENT-CIRCUIT/CIRCUIT ELEMENT SURFACE  
SMOOTH TOP/VITRIFIEE

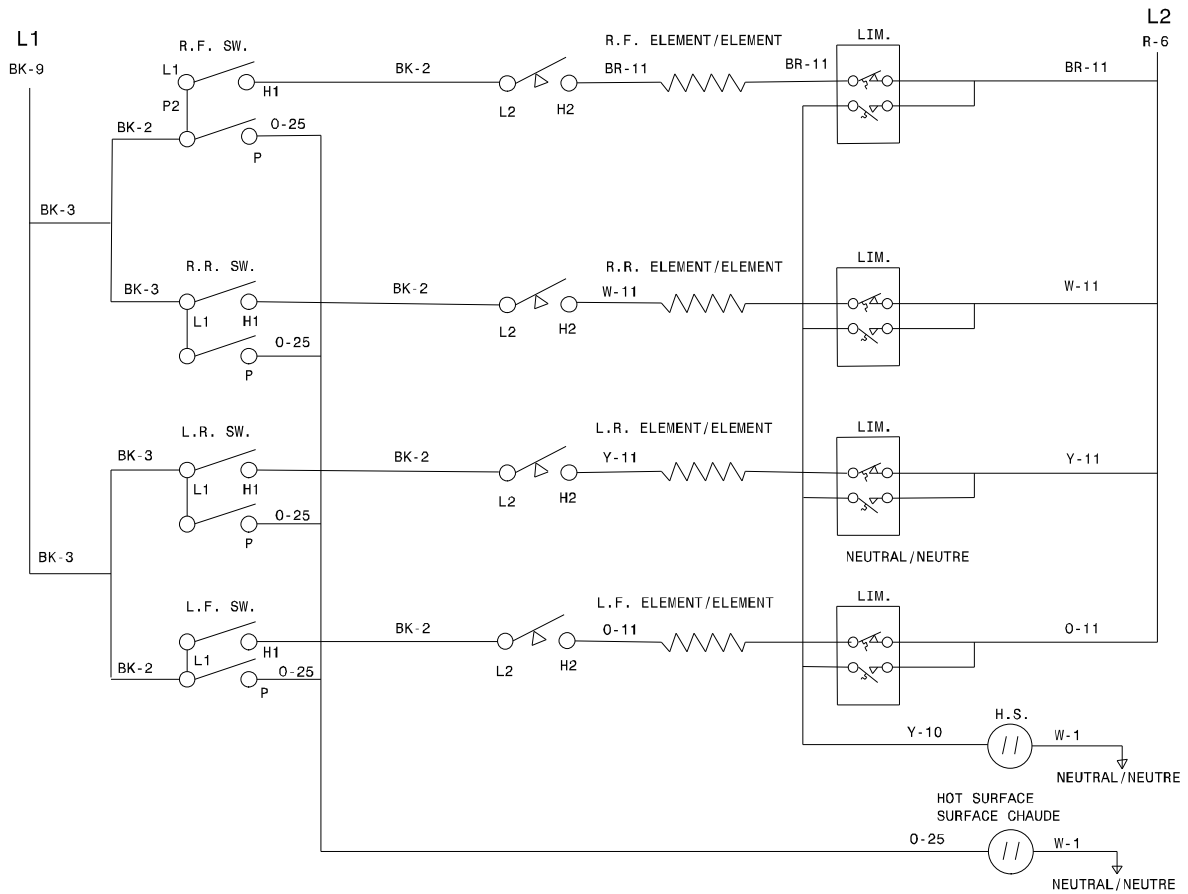

CAUTION: DISCONNECT POWER BEFORE SERVICING UNIT.  
 ATTENTION: COUPEZ L'ALIMENTATION AVANT D'EFFECTUER LA REPARATION.

318046791 REV:A  
 SHEET/FEUILLE:2/2