

Installation Instructions

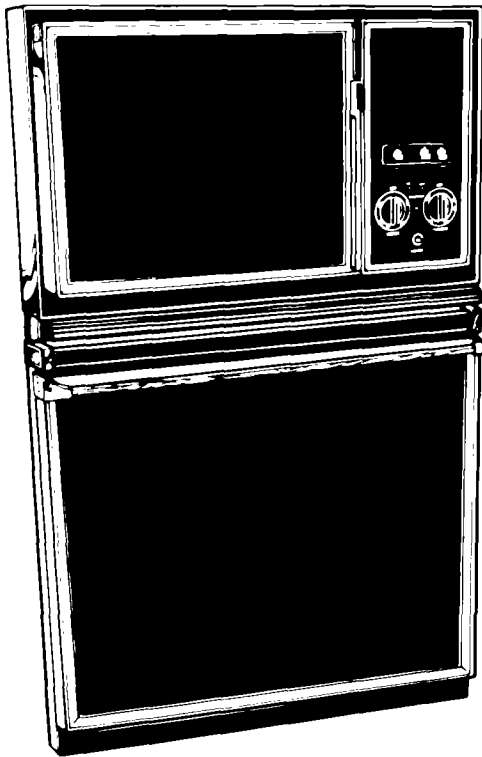

30" BUILT-IN MICROWAVE OVEN COMBINATION

IMPORTANT

INSTALLER: LEAVE THESE INSTRUCTIONS WITH THE HOMEOWNER.
HOMEOWNER: RETAIN THESE INSTRUCTIONS FOR FUTURE REFERENCE.

ave Ovens, Compactors, Room Air Conditioners, Dehumidifiers, Automatic Washers, Clothes Dryers, Freezers, Refrigerator-Freezers, Ice Makers, Dishwas

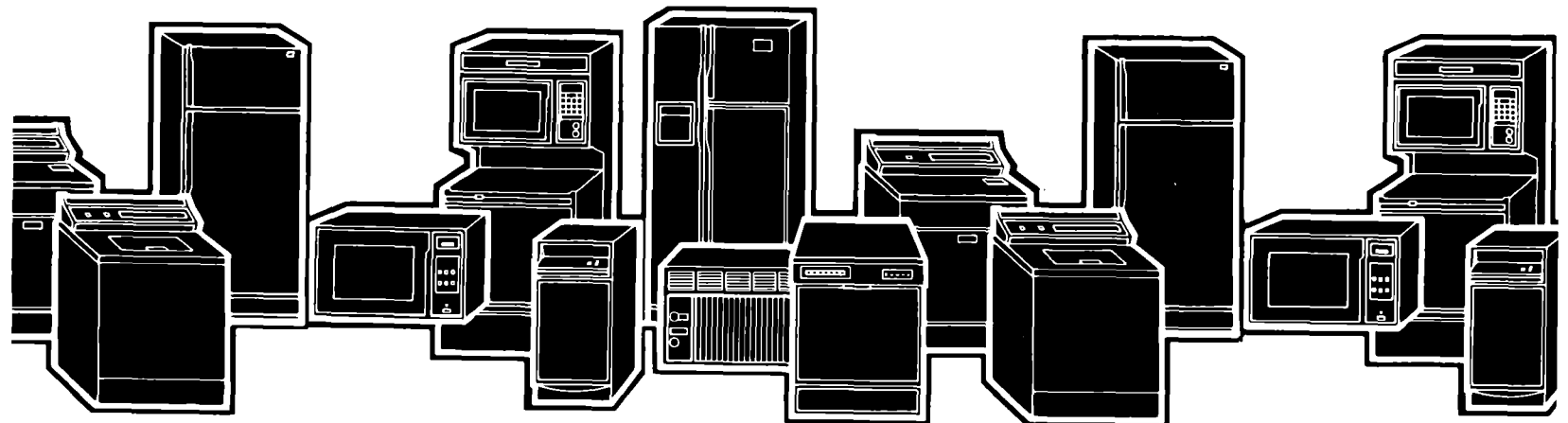

1 Before you begin

Read these instructions completely and carefully. If followed, they will simplify the installation job.

IMPORTANT:

Observe all governing codes and ordinances. Failure to follow these instructions could lead to fire or electrical shock hazard.

WARNING:
The microwave oven in this unit is designed for household use only. It must not be used for commercial purposes.

A. Space requirements

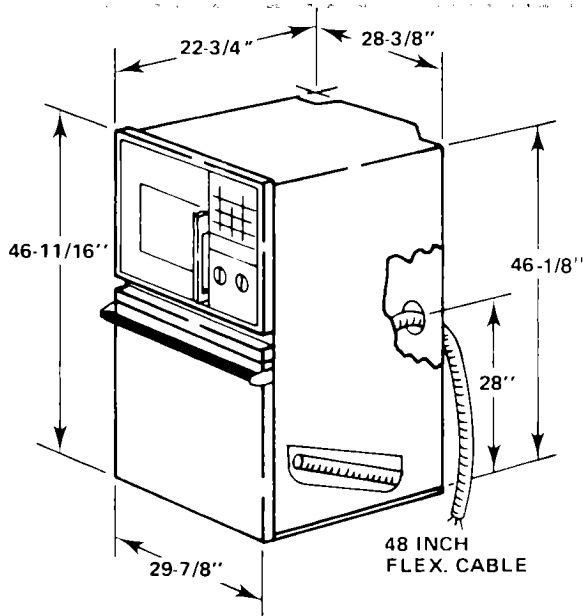

** 28-1/2" MINIMUM, IF 28-5/8" IS AVAILABLE THE CUTOUT SHOULD BE MADE 28-5/8".

The oven support surface may be solid plywood or similar material but the contact surface must be level from side to side and from front to rear. This surface is 2 3/4" below the open lower door height.

NOTE 1: The oven support surface must be flush with the bottom of the cabinet cutout.

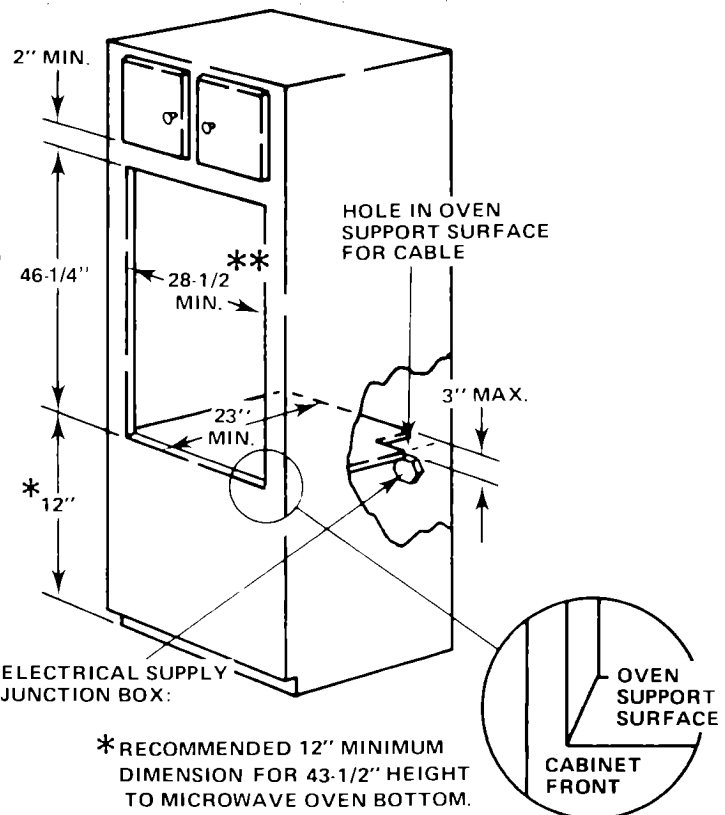

* RECOMMENDED 12" MINIMUM DIMENSION FOR 43-1/2" HEIGHT TO MICROWAVE OVEN BOTTOM.

SEE NOTE 1

PRECAUTIONS TO AVOID POSSIBLE EXPOSURE TO EXCESSIVE MICROWAVE ENERGY

Do not attempt to operate this oven with the door open since open-door operation can result in harmful exposure to microwave energy. It is important not to defeat or tamper with the safety interlocks.

Do not place any object between the oven front face and the door or allow soil or cleaner residue to accumulate on sealing surfaces.

Do not operate the oven if it is damaged. It is particularly important that the oven door close properly and that there is no damage to the:

1. Door (bent)
2. Hinges and latches (broken or loosened)
3. Door seals and sealing surfaces.

The oven should not be adjusted or repaired by anyone except properly qualified personnel.

The oven should be checked for microwave leakage by qualified service personnel after a repair is made.

Do not operate the oven if the door glass is broken.

Do not seal range to cabinets.

FIGURE 1



B. Check microwave for damage

Remove all packing material from the oven cavity. When unpacking the unit, check for damage such as misaligned door, damaged gaskets around the door, or dents inside the oven or on the exterior. If there is any damage, please do not operate the unit until it has been checked by an authorized Whirlpool trained service technician.

C. Electrical requirements

IMPORTANT:

SAVE THESE INSTRUCTIONS FOR THE LOCAL ELECTRICAL INSPECTOR'S USE

A. This appliance must be connected to the proper electrical voltage and frequency as specified on nameplate. Models rated at 15 KW on 240 volts (11.25 KW on 208V) or more require a separate 50 amp circuit. Models rated less than 15KW on 240 volts (11.25 KW on 208V) require a separate 40 ampere circuit. Fuse both sides of the line. **DO NOT** fuse the neutral. A time delay fuse or circuit breaker is recommended. Wire sizes must conform to the requirements of the National Electrical Code and/or local codes and ordinances for the kilowatt rating of the range. The nameplate is located on the front frame behind the microwave oven door.

NOTE: Wire sizes and connections must conform with the fuse size and rating of the appliance in accordance with National Electrical Code and local codes and ordinances. Do not use an extension cord.

B. The appliance should be connected to the fused disconnect (or circuit breaker) box through flexible armored or non-metallic sheathed cable. The flexible armored cable extending from the appliance should be connected directly to the junction box. The junction box should be located as shown in Figure 1 on page 2 so that as much slack as possible remains in the cable between the box and the appliance so that it can be moved if servicing is necessary.

C. A suitable strain relief must be provided to attach the flexible armored cable to the junction box.

2 Begin the installation

Remove racks and all other contents from oven before removing appliance.

A. Remove shipping skid

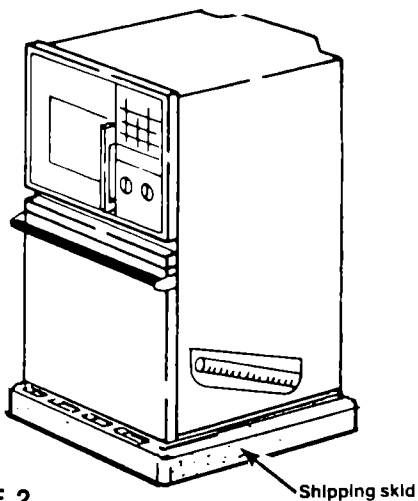

FIGURE 2

NOTE:

Before installing the oven in the cut-out, it may be helpful to remove the lower oven door. See details below.

Insert appliance into cut-out. Screws are provided for fastening the front frame of the appliance to the cabinet. The mounting holes in the front frame of appliance may be used as a template to locate the appliance mounting screw holes.

CAUTION:

For your personal safety, and to minimize potential personal injury, this oven must be securely fastened to the cabinet, using the four screws that are provided.

TO REMOVE OVEN DOOR—SELF-CLEANING MODELS (Door to be removed for installation only.)

1. Remove the two screws, one on each side of the inner door panel. See *View A*.

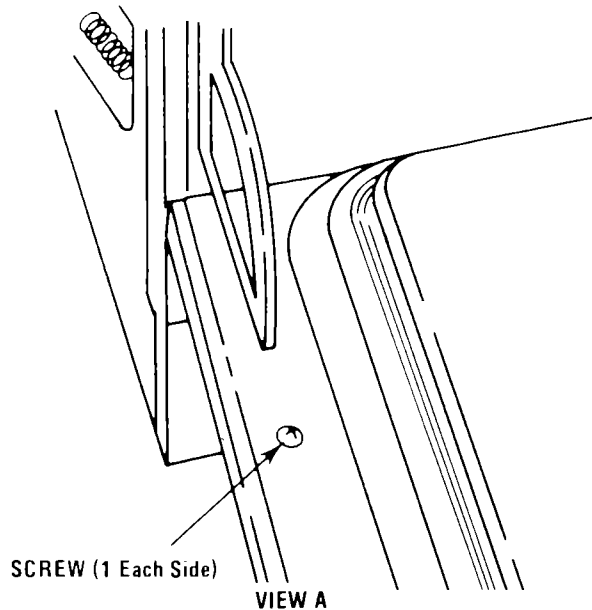

2. Put a nail (5/32" or smaller) or equivalent in the hole in each of the hinges. Close the oven door until the pins touch the oven front. See *View B*.
3. The oven door can now be lifted off.
4. Reinstall oven door the same as on non-self cleaning models. (See page 5)
5. Reinstall the door mounting screws.

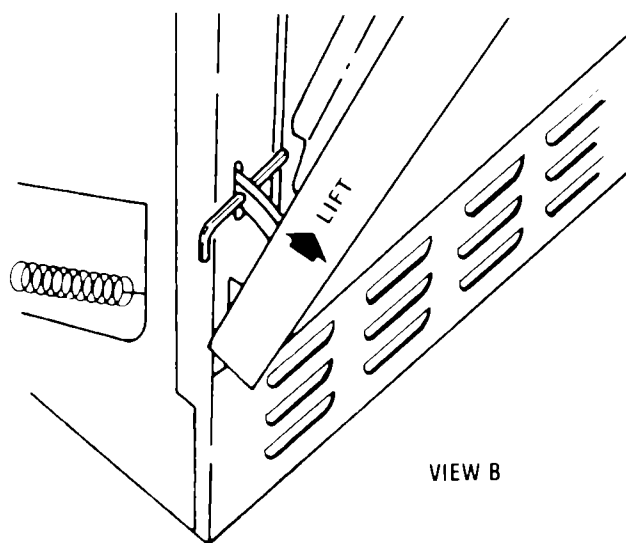

Installation Instructions



TO REMOVE OVEN DOOR (NON-SELF-CLEANING MODELS)

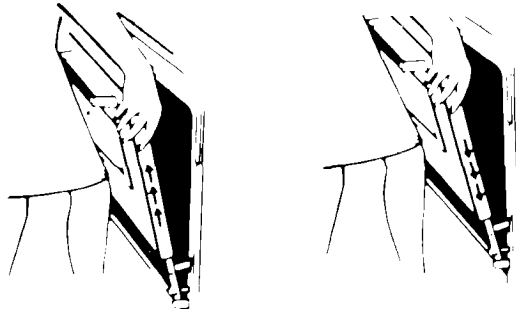

Pull straight with the angle of part-open door.

Push down evenly.

Removing the oven door may make it easier to clean the oven. To remove the door, first open it to the first stop (about 4 inches or 10 cm). Take hold of both sides of the door near the top; then lift it **at the same angle it is in**.

With the door off, you will notice how the ends of hinges slide into slots at the bottom corners of the door. To put the door back on, fit both corners of the door over the ends of the hinges. Push the door down evenly, so neither corner gets ahead of the other. When it reaches the bottom, you can close the door. A safety latch will hold the door open until it is on correctly.

Removing the oven door: (For installing and cleaning)

3 Make electrical connection

GROUNDING NEUTRAL

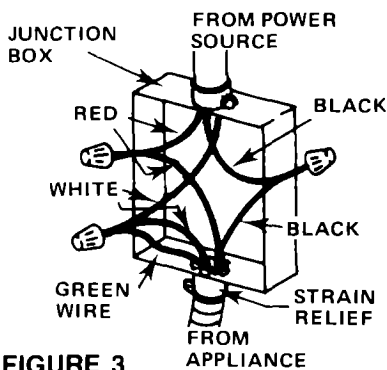

FIGURE 3

UNGROUNDING NEUTRAL

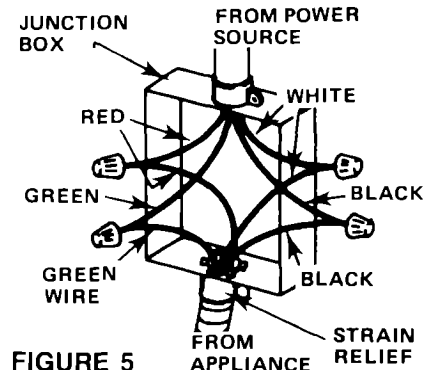

FIGURE 5

Grounding Instructions

WARNING: THIS APPLIANCE MUST BE CONNECTED TO A GROUNDED, METALLIC, PERMANENT WIRING SYSTEM, OR GROUNDING CONDUCTOR SHOULD BE RUN WITH THE CIRCUIT CONDUCTORS AND CONNECTED TO THE GROUNDING TERMINAL OR LEAD ON THE APPLIANCE.

Connect the flexible armored cable that extends from the unit to the junction box using a suitable strain relief at the point the armored cable enters the junction box. Then make the electrical connection as follows:

WARNING:
IT IS THE PERSONAL RESPONSIBILITY AND OBLIGATION OF THE CUSTOMER TO CONTACT A QUALIFIED INSTALLER TO ASSURE THAT THE ELECTRICAL INSTALLATION IS ADEQUATE AND IS IN CONFORMANCE WITH THE NATIONAL ELECTRICAL CODE AND LOCAL CODE ORDINANCES.

Electrical ground is required on this appliance.

This appliance is equipped with copper lead wires. If connection is made to aluminum house wiring, use only special connectors which are approved for joining copper and aluminum wires in accordance with the National Electrical Code and local codes and ordinances. This appliance is manufactured with a white neutral power supply wire and a frame connected green ground wire twisted together.

If local codes permit connection of the frame grounding conductor to the neutral (white) wire, connect the green and white wire from the supply cable of the appliance together and the neutral (white) wire in the junction box. Connect the remaining wires from the supply cable to the wires in the junction box. See Figure 3.

If local codes DO NOT permit frame grounding to the neutral, separate the white and green wires that extend out of the end of the supply cable of the appliance. See Figure 5. Connect the white wire from the supply cable to the neutral wire in the junction box. Connect the black and red wires from the supply cable, to the corresponding wires in the junction box. The green wire must now be used to ground the appliance in accordance with local electrical codes. Connect the green colored copper ground wire to a grounded cold water pipe* (see Figure 4) or to the grounded lead in the service panel.

Do not ground to a gas supply pipe. Do not connect to electric power supply until appliance is permanently grounded. Connect the ground wire before turning on the power. (See Figure 4.)

CAUTION — If connecting to a four-wire electrical system (MOBILE HOME) the appliance frame **MUST NOT** be connected to the neutral wire of the four-wire electrical system. Separate the white and green wires that extend out of the supply cable of the appliance. Connect the white, red and black wires from the supply cable to the corresponding wires in the junction box. Connect the green wire from the supply cable to the ground wire in the junction box. (See Figure 5.)

*Cold water pipe must have metal continuity to electrical ground and should not be interrupted by plastic, rubber or other electrically insulating connectors (including water meter or pump) without adding a jumper wire at those connectors.

4

Check operation



CAUTION:
DO NOT TOUCH ANY HEATING ELEMENTS. THEY MAY BE HOT AND YOU MAY BE BURNED.

A. Microwave oven

Refer to Use and Care Guide for details.

B. Oven elements

BAKE — Set selector switch on BAKE. Turn thermostat to 350° BAKE. The bottom element should glow red and indicator light should be on. The upper element should become hot but NOT glow red.

BROIL — Set selector switch on BROIL. Turn thermostat to high. The top element should glow red and indicator light should be on.

C. Rotisserie (if optional rotisserie kit is installed)

Place straight oven rack on bottom ledge position.

Place broiler pan on oven rack.

Place special rotisserie rack on broiler pan. Position the spit bar on this special rack.

Rotation should start when spit bar is inserted into receptacle in back of oven.

D. Clock

Refer to operating instructions in the Use and Care Guide (packed in the oven).

E. Cleaning

See the Use and Care Guide (packed in the oven) for proper care and cleaning instructions.

Installation Instructions



5 Before you call for service . . .

See the Use and Care Guide for trouble-shooting checklist.

Check for blown fuses or tripped circuit breaker.

If you must call for service. . .

You will need the appliance model and serial number.

Find the serial plate on the front frame of the microwave oven behind the microwave oven door.



Making your world a little easier.

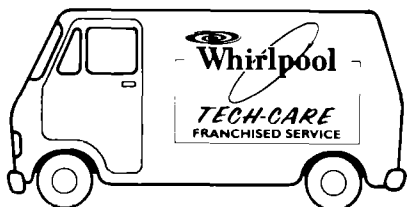

In the event your WHIRLPOOL appliance should need service, call the dealer from whom you purchased the appliance or a WHIRLPOOL franchised TECH-CARE[®] service company. He is in the Yellow Pages of your telephone directory listed under "Appliances-Household-Major-Service and Repair." You can also obtain his name and number by dialing, free, within the continental United States the Whirlpool COOL-LINE[®] Service (800) 253-1301. When calling from Michigan, dial (800) 632-2243; from Alaska or Hawaii, dial (800) 253-1121. Dial just as you normally dial long distance. A special operator will tell you the name and number of your nearest Whirlpool TECH-CARE service outlet. During normal working hours, Whirlpool consultants at this same number will also answer any questions about operating or maintaining your appliance not covered in your Use and Care Guide.

Learn the benefits of using TECH-CARE service for maintaining the quality originally built into your WHIRLPOOL appliance.

Part No. 313724 Rev. A

Printed in U.S.A.

difiers, Automatic Washers, Clothes Dryers, Freezers, Refrigerator-Freezers, Ice Makers, Dishwashers, Built-In Ovens and Surface Units, Ranges, Microw.

