

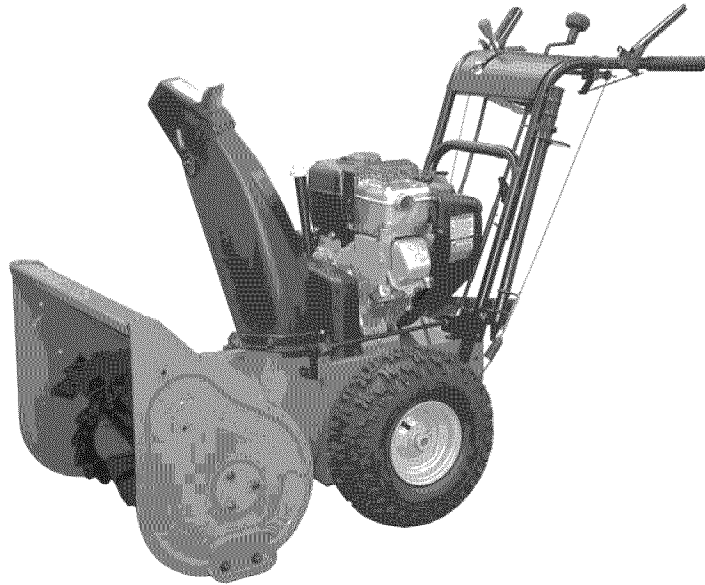

OPERATOR'S MANUAL



Intermediate Snowthrower Models

555 Models

Mfg. No.	Description
1694587	555M, 5HP, Manual Start
1694595	555M, 5HP, Manual Start (CE)
85665	I5225, 5HP, Manual Start
80494	EI5225, 5HP, Manual Start (CE)

7555 Models

Mfg. No.	Description
1694836	7555M, 7.5HP, Manual Start
1694837	7555EX, 7.5HP, Manual Start (CE)
7800000	I75225, 7.5HP, Manual Start
7800001	EI75225, 7.5HP, Manual Start (CE)

860 Models

Mfg. No.	Description
85666	I8245E, 8HP OHV, Electric Start
80495	EI8245, 8HP OHV, Manual Start (CE)
1694588	860E, 8HP OHV, Electric Start
1694596	860M, 8HP OHV, Manual Start (CE)

8560 Models

Mfg. No.	Description
7800017	I85245E, 8.5HP OHV, Electric Start
7800018	EI85245, 8.5HP OHV, Manual Start (CE)
1694845	8560EI, 8.5HP OHV, Electric Start
1694846	8560EX, 8.5HP OHV, Manual Start (CE)

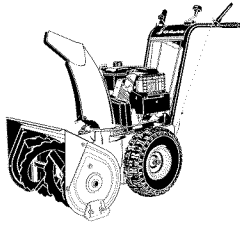

Table of Contents

Safety Rules & Information

Training	2
Preparation	2
Operation	2
Children	3
Clearing a Clogged Discharge Chute	3
Service, Maintenance and Storage	3
Emissions	3
Identifications Numbers	5
Decals	6
Safety Icons	7

Features, Controls, & Operation

Control Locations	8
Starting Controls	10
Ground Speed Controls	11
Auger Control	11
Deflector Controls	11
Scraper Height	11
Traction Lock Control	11

General Operation

Checks Before Each Start-Up	12
Starting The Engine	13
Operating The Snowthrower	14
Clearing a Clogged Discharge Chute	14
Ground Speed Selector	14
Engine Speed	14
Deflector	15
Scraper Bar & Skid Shoes	15
Free Wheeling and Traction Drive Lock	16
After Each Use	16

Regular Maintenance

Schedule	17
Checking Tire Pressure	17
Checking Auger Gear Case Lubrication	17
Lubrication	18
Check / Lubricate Free-hand Linkage	19
Lubricate Auger Shaft & Assembly	19
Storage	19

Troubleshooting, Adjustment, & Service

Troubleshooting	20
Speed Selector Pivot Adjustment	22
Traction Drive Clutch Cable Adjustment	22
Discharge Chute Worm Assy. Adjustment	23
Discharge Chute Control Rod Gear Adjustment	23
Auger Drive Clutch Cable Adjustment	24
Drive Belt Adjustment	24
Drive Belt Replacement	26
Roller Chain Replacement	28
Shear Pin Replacement	28

Specifications29

Replacement Parts & Accessories 30

Technical Manual availability30

WARNING

You must read, understand and comply with all safety and operating instructions in this manual before attempting to set-up and operate your snowthrower.

Failure to comply with all safety and operating instructions can result in loss of machine control, serious personal injury to you and /or bystanders, and risk of equipment and property damage. The triangle in the text signifies important cautions or warnings which must be followed.

WARNING

Engine exhaust from this product contains chemicals known, in certain quantities, to cause cancer, birth defects, or other reproductive harm.

Safety Rules & Information



This machine is capable to amputating hands and feet and throwing objects. Read these safety rules and follow them closely. Failure to obey these rules could result in loss of control of unit, severe personal injury or death to you, or bystanders, or damage to property or equipment. The triangle  in text signifies important safety information which must be followed.

TRAINING

1. Read, understand, and follow all instructions on the machine and in the manuals before operating this unit. Be thoroughly familiar with the controls and the proper use of the equipment. Know how to stop the unit and disengage the controls quickly.
2. Never allow children to operate the equipment. Never allow adults to operate the equipment without proper instruction.
3. Keep the area of operation clear of all persons, particularly small children and pets.
4. Exercise caution to avoid slipping or falling especially when operating in reverse.

PREPARATION

1. Thoroughly inspect the area where the equipment is to be used and remove all doormat, sleds, boards, wires, and other foreign objects.
2. Disengage all clutches and shift into neutral before starting engine (motor).
3. Do not operate the equipment without wearing adequate winter outer garments. Wear footwear that will improve footing on slippery surfaces. Avoid loose fitting clothing that can get caught in moving parts.
4. Handle fuel with care; it is highly flammable.
 - (a) Use an approved fuel container.
 - (b) Never add fuel to a running engine or hot engine.
 - (c) Fill fuel tank outdoors with extreme care. Never fill fuel tank indoors. Replace fuel cap securely and wipe up spilled fuel.
 - (d) Never fill containers inside a vehicle or on a truck or trailer bed with a plastic liner. Always place containers on the ground, away from your vehicle, before filling.
 - (e) When practical, remove gas-powered equipment from the truck or trailer and refuel it on the ground. If this is not possible, then refuel such on a trailer with a portable container, rather than from a gasoline dispenser nozzle.
 - (f) Keep nozzle in contact with the rim of the fuel tank or container opening at all times, until refueling is complete. Do not use a nozzle lock-open device.
 - (g) Replace gasoline cap securely and wipe up spilled fuel.
 - (h) If fuel is spilled on clothing, change clothing immediately.
5. Use extension cords and receptacles as specified by the manufacturer for all units with electric drive motors or electric starting motors.
6. Adjust the collector housing height to clear gravel or crushed rock surfaces.
7. Never attempt to make any adjustments while the engine (motor) is running (except when specifically recommended by the manufacturer).
8. Let engine (motor) and machine adjust to outdoor temperatures before starting to clear snow.
9. Always wear safety glasses or eye shields during operation or while performing an adjustment or repair to protect eye from foreign objects that may be thrown from the machine.

OPERATION

1. Do not put hands or feet near or under rotating parts. Keep clear of the discharge opening at all times.
2. Exercise extreme caution when operating on or crossing gravel drives, walks, or roads. Stay alert for hidden hazards or traffic.
3. After striking a foreign object, stop the engine (motor), remove the wire from the spark plug, disconnect the cord on electric motors, thoroughly inspect the snowthrower for any damage, and repair the damage before restarting and operating the snowthrower.
4. If the unit should start to vibrate abnormally, stop the engine (motor) and check immediately for the cause. Vibration is generally a warning of trouble.
5. Stop the engine (motor) whenever you leave the operating position, before unclogging the collector/impeller housing or discharge guide, and when making any repairs, adjustments, or inspections.
6. When cleaning, repairing, or inspecting make certain the collector/impeller and all moving parts have stopped. Disconnect the spark plug wire and keep the wire away from the plug to prevent accidental starting.
7. Do not run the engine indoors except for starting the engine or for transporting the snowthrower in or out of the building. Open the outside doors; exhaust fumes are dangerous.
8. Exercise extreme caution when operating on slopes. Do not attempt to clear steep slopes.
9. Never operate the snowthrower without proper guards, plates, or other safety protective devices in place and working.
10. Never direct the discharge toward people or areas where property damage can occur. Keep children and others away.
11. Do not overload the machine capacity by attempting to clear snow at too fast a rate.
12. Never operate the machine at high transport speeds on slippery surfaces. Look behind and use care when operating in reverse.
13. Disengage power to the collector/impeller when snowthrower is transported or not in use.
14. Use only attachments and accessories approved by the manufacturer of the snowthrower (such as wheel weights, counterweights, or cabs).
15. Never operate the snowthrower without good visibility or light. Always be sure of your footing, and keep a firm hold on the handles. Walk, never run.
16. Never touch a hot engine or muffler.
17. Never operate the snowthrower near glass enclosures, automobiles, window wells, drop-offs, and the like without proper adjustment of the discharge angle.
18. Never direct discharge at bystanders or allow anyone in front of the unit.
19. Never leave a running unit unattended. Always disengage the auger and traction controls, stop engine, and remove keys.
20. Do not operate the unit while under the influence of alcohol or drugs.

21. Keep in mind the operator is responsible for accidents occurring to other people or property.
22. Data indicates that operators, age 60 years and above, are involved in a large percentage of power equipment-related injuries. These operators should evaluate their ability to operate the unit safely enough to protect themselves and others from injury.
23. DO NOT wear long scarves or loose clothing that could become entangled in moving parts.
24. Snow can hide obstacles. Make sure to remove all obstacles from the area to be cleared.
8. Always follow the engine manual instructions for storage preparations before storing the unit for both short and long term periods.
9. Always follow the engine manual instructions for proper start-up procedures when returning the unit to service.
10. Maintain or replace safety and instruction labels as necessary.
11. Keep nuts and bolts tight and keep equipment in good condition.
12. Never tamper with safety devices. Check their proper operation regularly and make necessary repairs if they are not functioning properly.
13. Components are subject to wear, damage, and deterioration. Frequently check components and replace with manufacturer's recommended parts, when necessary.
14. Check control operation frequently. Adjust and service as required.
15. Use only factory authorized replacement parts when making repairs.
16. Always comply with factory specifications on all settings and adjustments.
17. Only authorized service locations should be utilized for major service and repair requirements.
18. Never attempt to make major repairs on this unit unless you have been properly trained. Improper service procedures can result in hazardous operation, equipment damage and voiding of manufacturer's warranty.
19. Check shear bolts and other bolts at frequent intervals for proper tightness to be sure the equipment is in safe working condition.

CHILDREN

Tragic accidents can occur if the operator is not alert to the presence of children. Children are often attracted to the unit and the operating activity. Never assume that children will remain where you last saw them.

1. Keep children out of the area and under the watchful care of another responsible adult.
2. Be alert and turn unit off if children enter the area.
3. Never allow children to operate the unit.
4. Use extra care when approaching blind corners, shrubs, trees, or other objects that may obscure vision.

CLEARING A CLOGGED DISCHARGE CHUTE

Hand contact with the rotating impeller inside the discharge chute is the most common cause of injury associated with snowthrowers. Never use your hand to clean out the discharge chute.

To clear the chute:

1. SHUT OFF THE ENGINE.
2. Wait 10 seconds to be sure the impeller blades have stopped rotating.
3. Always use a clean out tool, not your hands.

SERVICE, MAINTENANCE, AND STORAGE

1. Check shear bolts and other bolts at frequent intervals for proper tightness to be sure the equipment is in safe working condition.
2. Never store the machine with fuel in the fuel tank inside a building where ignition sources are present such as hot water and spacer heaters, or clothes dryers. Allow the engine to cool before storing in any enclosure.
3. Always refer to the operator's manual for important details if the snowthrower is to be stored for an extended period.
4. Maintain or replace safety and instruction labels as necessary.
5. Run the machine a few minutes after throwing snow to prevent freeze-up of the collector/impeller.
6. If fuel is spilled, do not attempt to start the engine but move the machine away from the area of spillage and avoid creating any source of ignition until fuel vapors have dissipated.
7. Always observe safe refueling and fuel handling practices when refueling the unit after transportation or storage.

EMISSIONS

1. Engine exhaust from this product contains chemicals known, in certain quantities, to cause cancer, birth defects, or other reproductive harm.
2. If available, look for the relevant Emissions Durability Period and Air Index information on the engine emissions label.

Blank lined writing area.

Identification Numbers

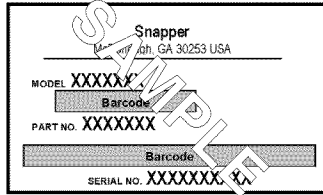

North American / CE Models

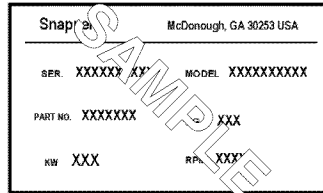

CE Models (only)

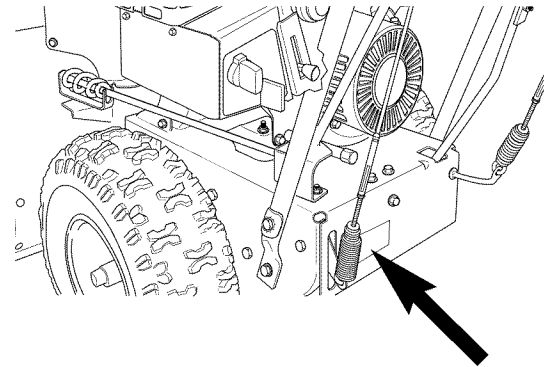

ID Tag Location

Identification Numbers

When contacting your authorized dealer for replacement parts, service, or information you **MUST** have these numbers.

Record your model name/number, manufacturer's identification numbers, and engine serial numbers in the space provided for easy access. These numbers can be found in the locations shown.

NOTE: For location of engine identification numbers, refer to the engine owner's manual.

PRODUCT REFERENCE DATA	
Model Description Name/Number	
Unit MFG Number	Unit SERIAL Number
Mower Deck MFG Number	Mower Deck SERIAL Number
Dealer Name	Date Purchased
ENGINE REFERENCE DATA	
Engine Make	Engine Model
Engine Type/Spec	Engine Code/Serial Number

CE IDENTIFICATION TAG MARKINGS

- A. Manufacturer's Identification Number (Part Number)
- B. Manufacturer's Serial Number
- C. Power Rating in Kilowatts
- D. Maximum Engine Speed in Rotations per Minute
- E. Manufacturer's Address
- F. Year of Manufacture
- G. CE Compliance Logo
- H. Mass of Unit in Kilograms
- I. Sound Power in Decibels *
- J. Model Number

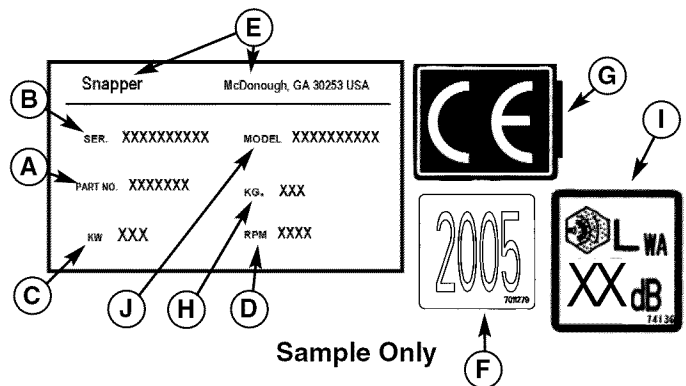

Sample Only

NOTE: Decal format and configuration may differ from illustration.

See page 29 for actual CE compliance information.

* See page 29 for CE compliance information regarding sound pressure and vibration.

Safety Decals

GENERAL

This unit has been designed and manufactured to provide you with the safety and reliability you would expect from an industry leader in outdoor power equipment manufacturing.

Although reading this manual and safety instructions it contains will provide you with the necessary basic knowledge to operate this equipment safely and effectively, we have placed several safety labels on the unit to remind you of this important information while you are operating your unit.

All safety and instructional messages on your unit should be carefully read and obeyed. Personal bodily injury can result when these instructions are not followed. The information is for your safety and it is important. The safety decals below are on your unit.

If any of these decals are lost or damaged, replace them at once. See your local dealer for replacements.

These labels are easily applied and will act as a constant visual reminder to you, and others who may use the equipment, to follow the safety instructions necessary for safe, effective, operation.

NORTH AMERICAN MODEL DECALS

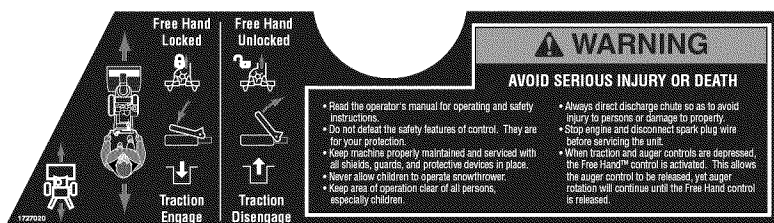

Part No. 1727020

WARNING / Main Dash Decal, North American Models

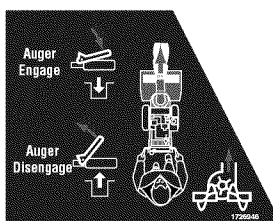

Part No. 1726946

Auger Control Decal



Part No. 7071880

Discharge Chute Danger Decal



Part No. 1716532

Auger Danger Decal

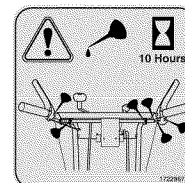

Part No. 1722867

Lubrication Decal

CE MODEL DECALS



Part No. 1727021

WARNING / Main Dash Decal, CE Models

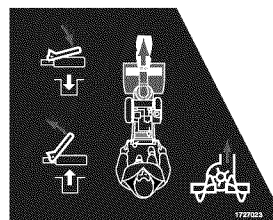

Part No. 1727023

Auger Control Decal

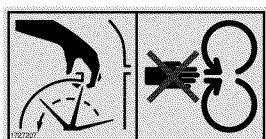

Part No. 1727207

Discharge Chute Danger Decal

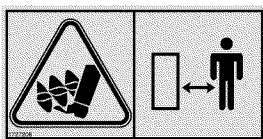

Part No. 1727208

Auger Danger Decal

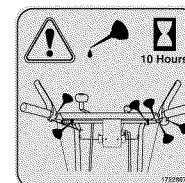

Part No. 1722867

Lubrication Decal

CE Safety Icons & Compliance Specs

Warning: Read Operator's Manual.

Read and understand the Operator's Manual before using this machine.

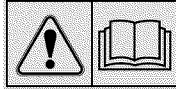

Danger: Thrown Objects.

This machine is capable of throwing objects and debris. Keep bystanders away.

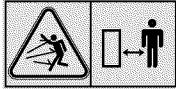

Warning: Remove Key Before Servicing.

Remove the key, disconnect spark plug wire, and consult technical literature before performing repairs or maintenance.



Warning: Dismemberment.

This machine can amputate limbs. Keep bystanders and children away when engine is running.

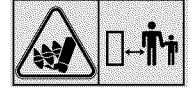

Danger: Dismemberment.

The auger can amputate limbs. Keep hands and feet away from auger and rotating parts.



Danger: Dismemberment.

The impeller can amputate limbs. Stop the engine, remove the key, and disconnect spark plug wire before clearing the discharge chute or performing service work. Keep hands and feet away from impeller and rotating parts.

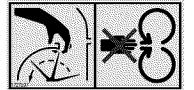

Features, Controls, & Operation

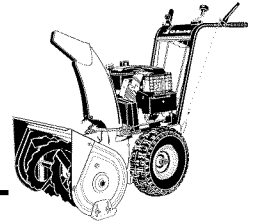

Please take a moment and familiarize yourself with the name, location, and function of these controls so that you will better understand the safety and operating instructions provided in this manual.

ALL MODELS

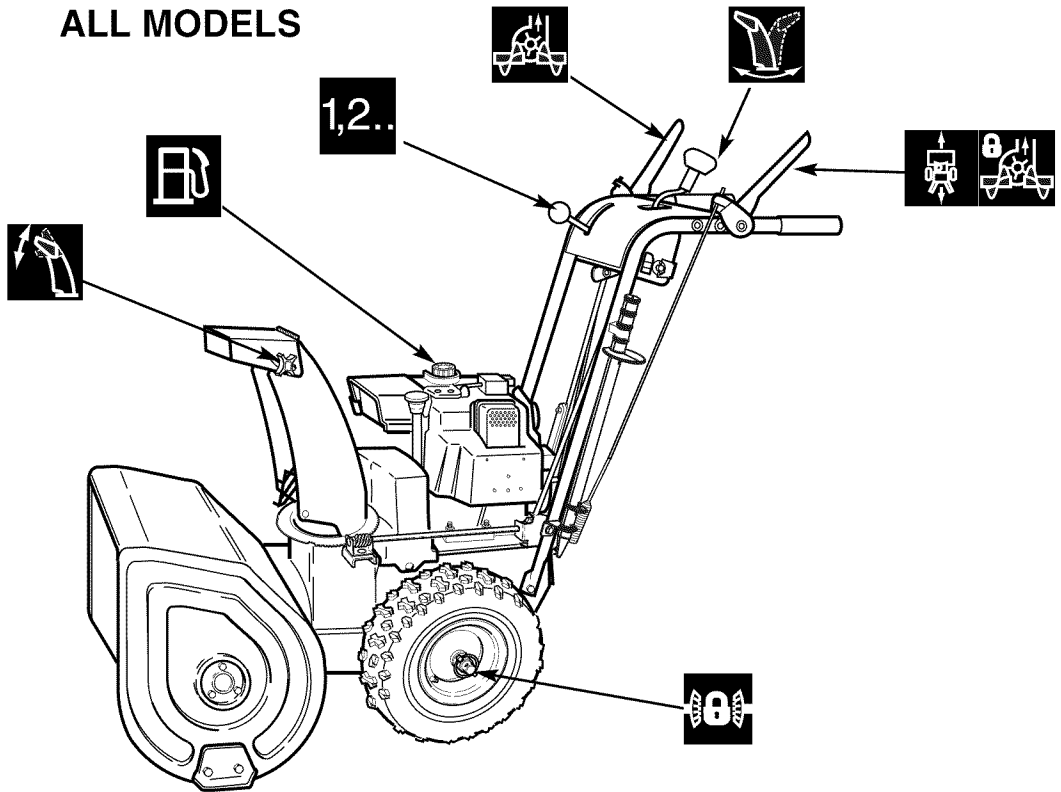

TECUMSEH MODELS

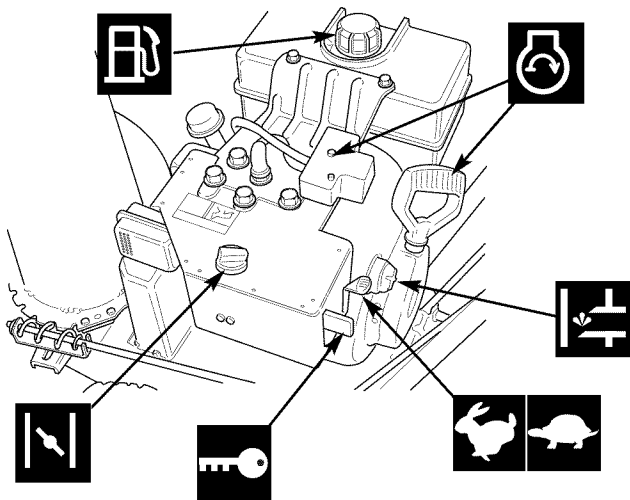

BRIGGS & STRATTON MODELS

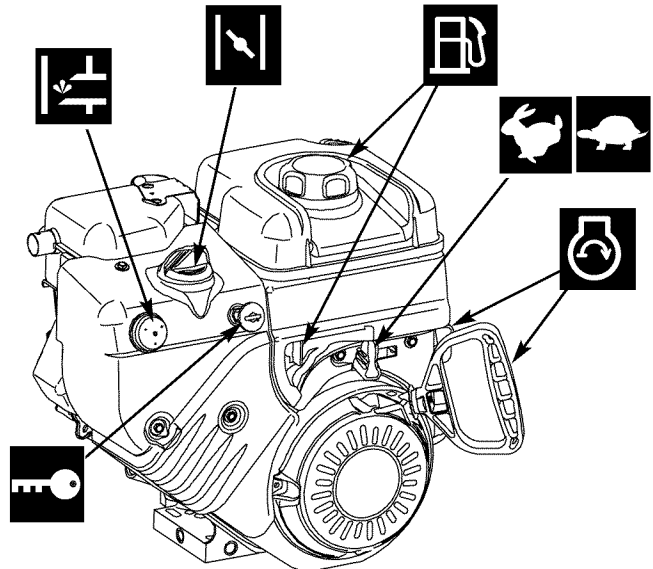

CONTROL LOCATIONS

The information below briefly describes the function of individual controls. Starting, stopping, and driving require the combined use of several controls applied in specific sequences. To learn what combination and sequence of controls to use for various tasks see the OPERATION section.

Speed Selector

Selects forward speeds 1-5 and reverse speeds 1-2.



Traction Control / Free Hand™ Lock

Engages traction drive to wheels when depressed. Also locks auger control when depressed simultaneously. Releasing the traction control lever releases the Free Hand™ auger control lock and stops the drive wheels.



Auger Control

Engages the auger/impeller when depressed. Releasing the control stops the auger/impeller.



Chute Direction Control

Rotates the discharge chute to desired position.



Chute Deflector Knob

Locks chute deflector in desired position.



Traction Lock Pins

The traction drive to each wheel can be locked and unlocked with the Traction Lock Pins (H, Figure 4) to permit the unit to “free-wheel,” allowing easier manual handling and transport of the snowthrower.



Electric Start Button (Optional)

Activates electric starter.



Fuel

Fuel tank filler cap (see illustration). Note: The fuel shut off valve is located under the fuel tank. Close the valve when the snowthrower is not in use. Open the valve before starting.



Starter Handle

Used to pull-start the engine.



Primer Button

Primes carburetor for faster cold starting.



Throttle Lever

Controls engine speed. Move toward the hare icon for faster engine speed, move toward the turtle icon for slower engine speed. Move the throttle all the way to STOP to stop the engine.



Engine Key

Prevents starting of engine without key. Stops engine when removed.



Choke Knob

Adjusts air/fuel mix for easier cold weather starting.

Engine Controls

STARTING CONTROLS

See Figures 1 & 2 for the following instructions.

Units with Optional Electric Start

A. Electric Start Button (North American Models)- The electric start button (A) activates an electric starter mounted to the engine, eliminating the need to pull the starter handle. The electric start button operates on 120 Volts AC, which is provided by connection to the extension cord provided with units equipped with this feature. **Connect this extension cord ONLY to a properly grounded 3 prong electrical outlet.**

Electric Start Button (CE Models)- Please refer to the detailed instructions supplied with the electric start kit.

Manual Start

- B. Fuel Valve** - The fuel valve (B) is located under the fuel tank. It is used to turn the fuel supply off for out-of-season storage.
- C. Starter Handle** - The starter handle (C) connects to a starter cord to manually start the engine. Pulling starter handle rapidly spins the engine crankshaft, cycles the engine, and generates the spark necessary for starting the engine.
- D. Primer Button** - When pressed, the primer button (D) provides initial fuel to help start a cold engine. Normally, pressing the primer button twice will provide enough fuel to start a cold engine.
- E. Throttle Lever** - The throttle lever (E) controls the engine speed. For best overall performance, the throttle lever should be set to the **FAST** position. Use the **SLOW** position only for warming the engine, or to help prevent snow/ice freeze-up when shutting the unit down for the day.
- F. Engine Key** - The engine key (F) prevents the engine from being started by unauthorized individuals. The key must be fully inserted into the key slot for the unit to start. The key is also used to stop the engine by pulling the key out of the key slot.
- G. Choke Knob** - The choke knob (G) adjusts the air/fuel mixture, and is used to help start a cold engine by providing a richer mixture. Once the engine is warm and running smoothly, the choke knob should be set to the off position to provide a normal air/fuel mix.

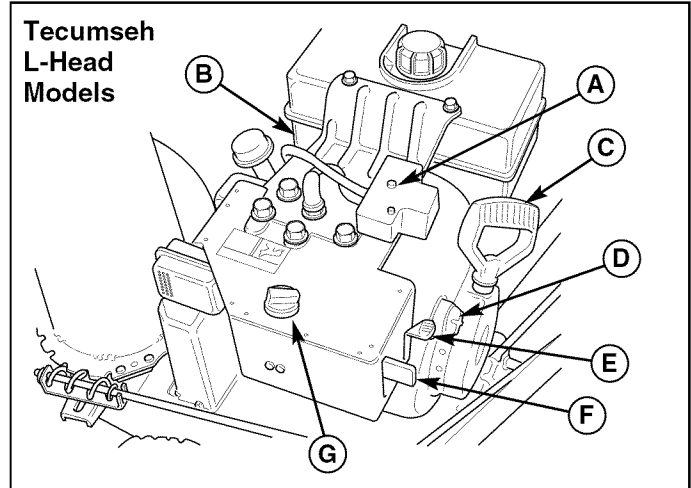

Figures 1. Engine Controls

- A. Electric Start Button
- B. Fuel Valve
- C. Starter Handle
- D. Primer Button
- E. Throttle Lever
- F. Engine Key
- G. Choke Knob

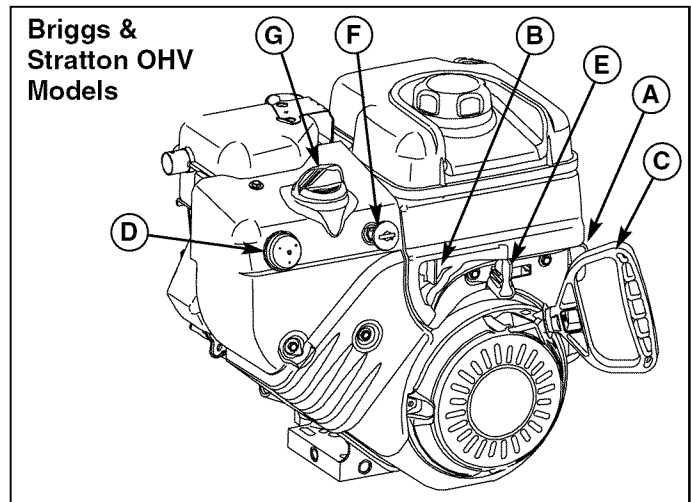

Figures 2. Engine Controls

- A. Electric Start Button
- B. Fuel Valve
- C. Starter Handle
- D. Primer Button
- E. Throttle Lever
- F. Engine Key
- G. Choke Knob

GROUND SPEED CONTROLS

A. Speed Selector - This lever (A, Figures 3 & 4) is used to set the ground speed of the snowthrower.

The snowthrower has five forward speeds, 1–5, and two reverse speeds, 1–2. No neutral position or gate is required, since the traction drive design automatically provides "neutral" (no forward or reverse movement), whenever the drive control is released.

B. Traction & Free Hand™ Control - This control engages the traction drive as the lever (B, Figures 3 & 4) is depressed, and disengages the traction drive when the lever is released. When both levers are depressed the Free Hand™ control is activated. This allows the auger control to be released yet the auger remains engaged until the traction Free Hand™ is released. **NOTE:** Changing ground speeds must only be done while the drive control is in the disengaged (fully released) position.

AUGER CONTROL

C. Auger Control - The auger control clutch lever (C Figures 3 & 4), engages the auger drive when the lever is depressed and disengages the auger drive when the lever is released (unless Traction Free Hand™ control is also depressed-see above).

DEFLECTOR CONTROLS

D. Chute Direction Control - The chute direction control (D, Figures 3 & 4), allows the discharge chute to be rotated to throw snow in the desired direction. Snow may be thrown at any angle from straight left, to straight forward, to straight right.

E. Chute Deflector - Controls the distance snow is thrown. Tilting the chute deflector (E, Figure 4) UP provides a higher stream and greater distance, while tilting the deflector DOWN provides a lower stream and less distance.

F. Chute Deflector Knob - This knob (F, Figure 4) allows the discharge chute deflector (E) to be locked in the desired tilt position.

SCRAPER HEIGHT

G, H. Scraper Bar Height Control - The skid shoes (G, Figure 4) control the height of the scraper bar (H). (NOTE: On later models, the scraper bar is also adjustable.) The scraper bar allows smooth surfaces (such as concrete or asphalt driveways) to be scraped clean of snow. On surfaces such as gravel, the scraper bar should be adjusted higher — so that it will not pick up gravel or debris.

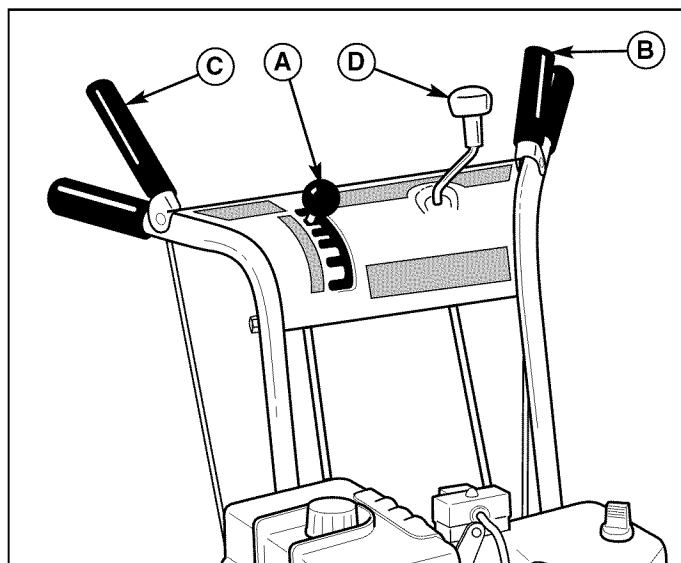

Figure 3. Operator's Control Position
A. Speed Selector **C. Auger Control**
B. Drive Control **D. Chute Direction Control**

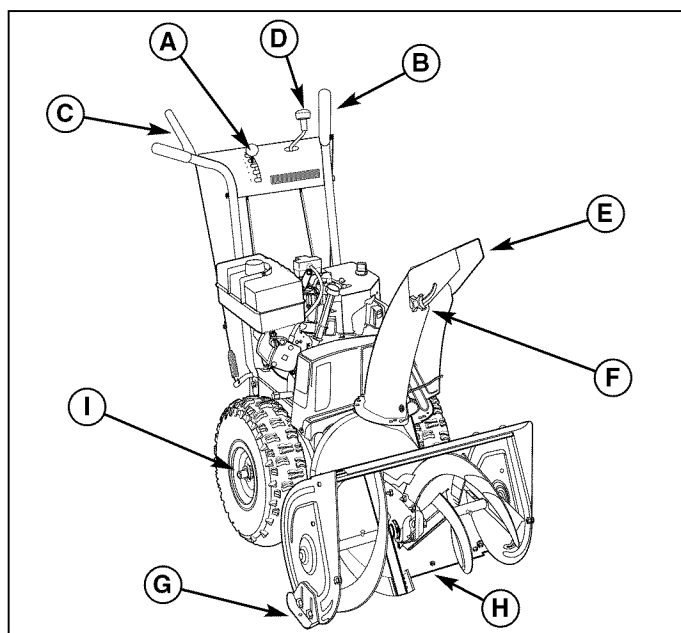

Figure 4. Snowthrower Controls
A. Speed Selector **E. Chute Deflector**
B. Drive Control **F. Chute Deflector Knob**
C. Auger Control **G. Skid Shoes**
D. Chute Control Knob **H. Scraper Bar**
I. Traction Lock Pins

TRACTION LOCK CONTROL

I. Traction Lock Pins - The traction drive to each wheel can be locked and unlocked with the traction lock pins (I, Figure 4) to permit the unit to "free-wheel," allowing easier manual handling and transport of the snowthrower.

GENERAL OPERATION

CHECKS BEFORE EACH START-UP

1. Make sure all safety guards are in place and all nuts, bolts and clips are secure.
2. Check to make sure that the clean-out tool is attached to the handle on the machine. Do not operate the machine without the clean-out tool properly stored on the handle.
3. Check the engine oil level. See your engine owner's manual for procedure and specifications.
4. Check to make sure spark plug wire is attached and spark plug is tightened securely. If necessary, torque spark plug to 15 ft. lbs.
5. Check the fuel supply. Fill the tank no closer than 1/4 to 1/2 inch of top of tank to provide space for expansion. See your engine owner's manual for fuel recommendations.
6. Check the scraper bar to make sure it is set at the desired height. Adjust the scraper bar height if necessary. (See page 15.)
7. Check the drive control (B, Figure 3), and Auger Control (C) for proper operation. The auger and impeller must stop within 5 seconds of releasing the Auger Control (C). If adjustment is required, see the Service Section for procedures.
8. Check the chute direction control (D, Figure 3) for proper operation. The discharge chute should rotate freely in both directions. See the Service Section for adjustment procedures and troubleshooting.
9. Check the chute deflector (E, Figure 3) for proper operation. The deflector should pivot freely up and down when the chute deflector knob is loosened. If adjustment is required, see the Service Section for procedures.
10. Position the chute at the desired starting direction and set the deflector at the desired angle.
11. Check the speed selector (A, Figure 3) for smooth operation. The control must move freely into each speed position gate and remain in position when released. If the speed selector does not move freely into all forward and reverse speed positions, contact your local authorized dealer for assistance.

WARNING

This unit is a “two-stage” snowthrower.

The first stage is the auger, which feeds the snow back into the impeller housing. The second stage is the impeller, which throws the snow out the discharge chute. If bodily contact is made with the auger or impeller when they are rotating, severe personal injury will occur.

To avoid injury, keep others and yourself away from the auger and the discharge chute whenever the engine is running. Read and follow all of the safety rules and warnings in this manual.

DANGER

Do not clean out discharge chute with hands. Contact with moving parts inside chute will cause serious injury. Use clean-out tool provided with machine. Use the following procedure to remove objects or clear the chute:

1. Stop the engine. Remove the key
2. Wait 10 seconds to be sure the auger/impeller blades have stopped rotating.
3. Always use the clean-out tool. DO NOT use your hands.

WARNING

For your safety, operation on slopes should be in an up and down direction only. If it becomes necessary to move across the face of a slope, use caution and do not blow snow. Be very careful when changing direction on a slope.

Proper winter footwear is recommended for the operator to help prevent slipping. Never attempt to clean snow from excessively steep slopes. The maximum slope for any operation is 17.7% (10°).

WARNING

Gasoline is highly flammable and must be handled with care. Never fill the tank when the engine is hot or running. Always move outdoors to fill the tank. Keep snowthrower and gasoline away from open flame or spark.

STARTING THE ENGINE

1. Turn the fuel valve (B, Figure 5 & 6) to the ON position.
2. Insert the engine key (F) into the engine key slot and push fully in to the RUN position.
3. Move the throttle lever (E) fully up to the FAST position.
4. Fully close the choke (G) if engine is cold. (Do not choke a warm engine.)
5. Push the primer button (D) two times if engine is cold. (Do not prime a warm engine.)
6. Pull starter handle (C) rapidly, or push starter button if equipped with the electric start. Do not allow the starter handle to snap back—let the starter rope rewind slowly—while keeping a firm grip on the starter handle.
7. As the engine starts and begins to operate evenly, open the choke (G) slowly and set the throttle lever to SLOW. If the engine falters, turn the choke knob clockwise until the engine runs smoothly, and let it run briefly before returning the choke to the OPEN position.

NOTE: Allow the engine to warm up at SLOW throttle for a few minutes before operating the snowthrower at full speed. The engine will not develop full power until it reaches operating temperature.

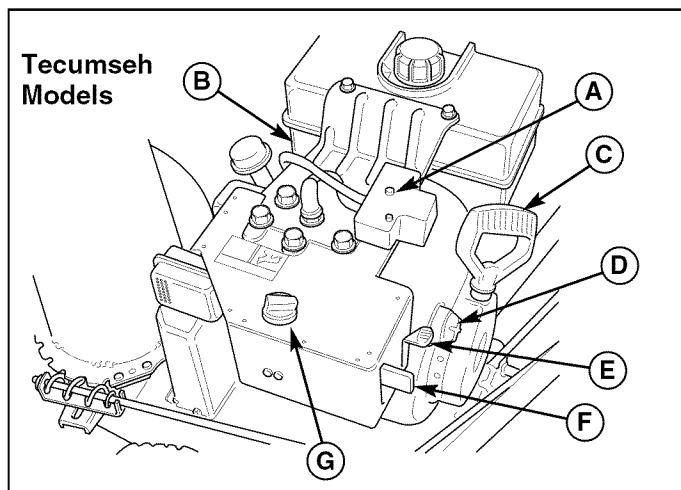

Figures 5. Engine Controls

- | | |
|---------------------------------|--------------------------|
| A. Electric Start Button | E. Throttle Lever |
| B. Fuel Valve | F. Engine Key |
| C. Starter Handle | G. Choke Knob |
| D. Primer Button | |

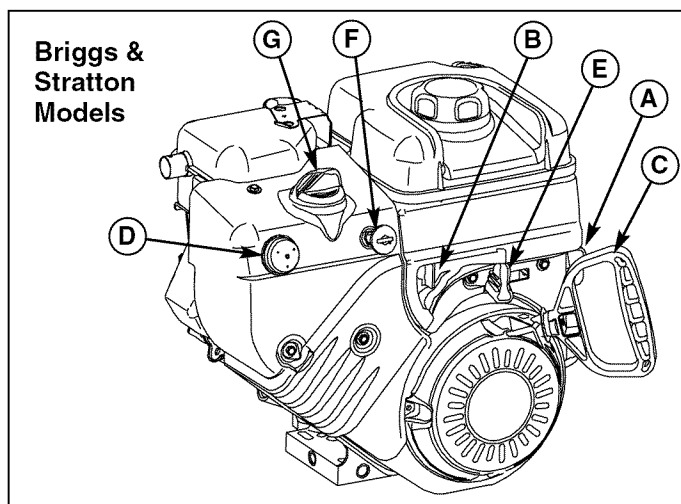

Figures 6. Engine Controls

- | | |
|---------------------------------|--------------------------|
| A. Electric Start Button | E. Throttle Lever |
| B. Fuel Valve | F. Engine Key |
| C. Starter Handle | G. Choke Knob |
| D. Primer Button | |

Operation

OPERATING THE SNOWTHROWER

1. Rotate the discharge chute to the desired direction.
2. Set the speed selector to the desired forward speed.
3. Fully press and hold the auger control (C, Figure 7) on the right-hand grip to begin auger rotation. To disengage the auger, completely release the lever.
4. Fully press and hold the traction drive control lever (B, Figure 7) on the left-hand grip to engage the traction drive and begin moving the snowthrower. To disengage the traction drive, completely release the lever. If engaged at the same time, the drive control (B) will lock the auger control (C) in the engaged position. Releasing the drive control (B) will release the auger control (C).
5. Select forward or reverse speeds as needed using the speed selector (A, Figure 7). Release the drive control lever whenever changing drive speeds.

NOTE: After 5 - 10 hours of use, it may be necessary to adjust the tension on the traction drive cable. See "Traction Drive Clutch Cable Adjustment" in the Service Section for the adjustment procedure.

CLEARING A CLOGGED DISCHARGE CHUTE

Hand contact with the rotating auger/impeller inside the discharge chute is the most common cause of injury associated with snowthrowers. **DO NOT** use your hand to clean out the discharge chute. To clear the chute:

1. Stop the engine. Remove the key.
2. Wait 10 seconds to be sure the auger/impeller blades have stopped rotating.
3. Always use the clean-out tool. **DO NOT** use your hands.

GROUND SPEED SELECTOR

Use the speed selector (A, Figure 7) to control the drive speed of the snowthrower. There are five forward speeds and two reverse speeds.

Use the lower speeds to blow deep or wet snow. Use the higher speeds to blow light snow or to drive the snowthrower without blowing snow.

To change speeds, first release the traction drive control lever (B, Figure 7), then move the speed selector to the desired speed setting. Fully press the traction drive control lever to resume operation.

ENGINE SPEED

Run the engine at full throttle when operating. Use the engine throttle lever (See Figure 8) to set the engine speed. Slide the throttle lever **UP** to increase engine speed, and **DOWN** to reduce speed.

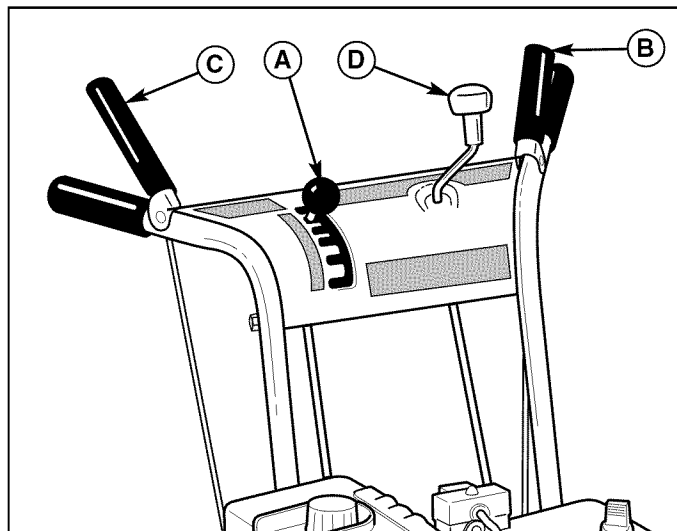

Figure 7. Operator's Control Position
A. Speed Selector C. Auger Control
B. Drive Control D. Chute Direction Control

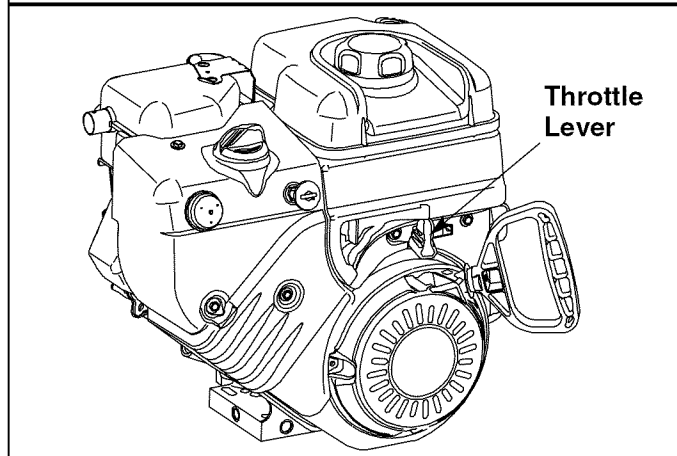
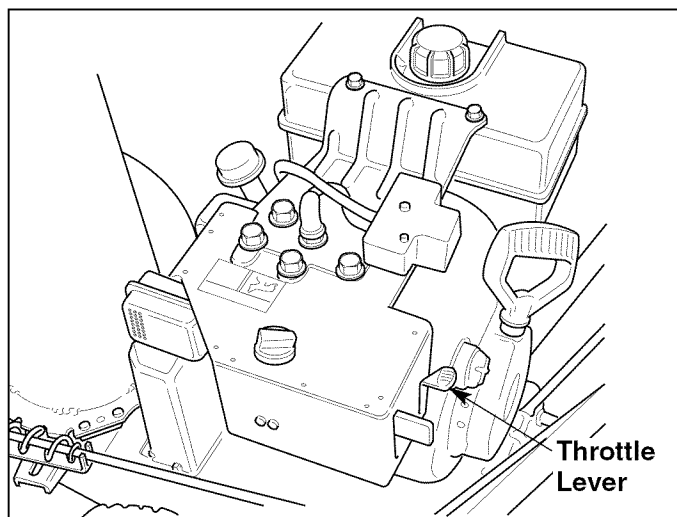

Figure 8. Engine Speed Selection

DEFLECTOR

The distance of the discharged snow is mainly controlled by the position of the deflector (Figure 9). (Engine speed also affects distance of discharge. Always operate at FULL throttle.)

The more the deflector is tilted UP, the farther snow will be thrown. Loosen the deflector knob, tilt the deflector UP or DOWN, and then retighten the knob when the desired angle has been chosen.

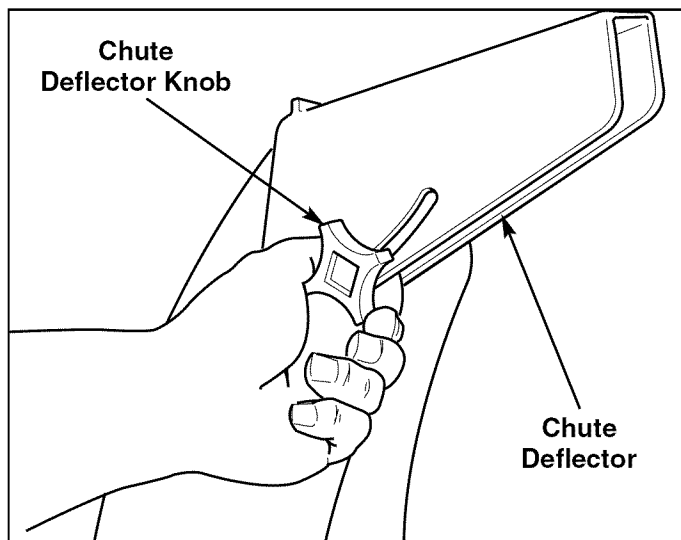

Figure 9. Chute Deflector Adjustment

SCRAPER BAR & SKID SHOES

On smooth surfaces such as concrete or asphalt, the scraper bar should scrape the surface. On surfaces such as gravel, the scraper bar should be high enough so that it will not pick up gravel or debris.

The height of the scraper bar is controlled by raising or lowering the skid shoes (See Figure 10).

1. To raise the scraper bar height, rest the scraper bar on a strip of wood equal in thickness to the desired height.
2. Make sure the scraper bar is parallel to the ground surface.
3. Loosen the skid shoe nuts and let the skid shoes drop to the surface.
4. Tighten the nuts, making sure the skid shoes are adjusted equally and are parallel to the surface.
5. To lower the height of the scraper bar, raise the skid shoes.
6. If the scraper bar becomes worn, it can be replaced by removing the hardware attaching it to the snowthrower.

On later models, the scraper bar is adjustable. (See Figure 10a). If desired scraper bar height adjustment cannot be achieved solely by raising or lowering the skid shoes:

1. Loosen the nuts securing the scraper bar to the auger housing, and raise or lower the scraper bar until desired height is achieved.
2. Tighten the nuts, making sure the scraper bar is parallel with the bottom edge of the auger housing.

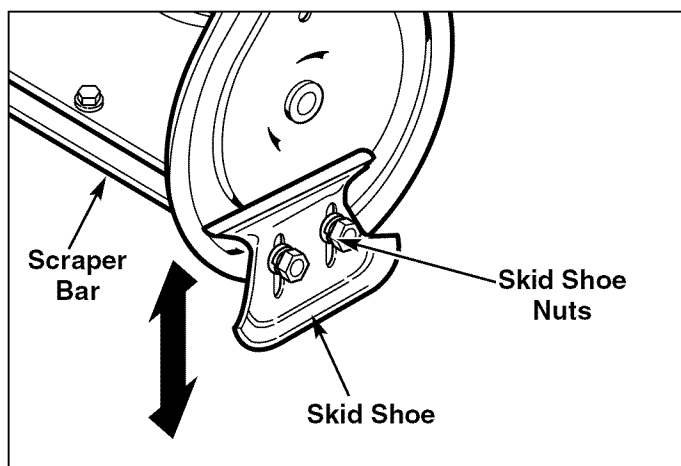

Figure 10. Skid Shoe Adjustment

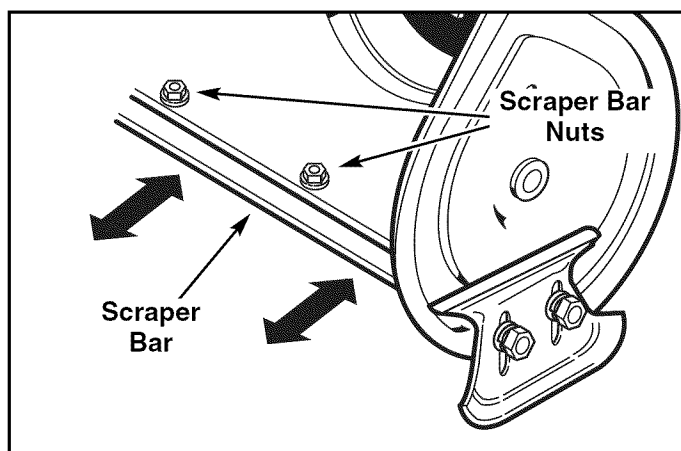

Figure 10a. Scraper Bar Adjustment (Later Models)

Operation

FREE-WHEELING AND TRACTION DRIVE LOCK

For easy turning when pushing the snowthrower, you can disengage the traction drive at one or both wheels by using the traction lock pins (See Figures 11 & 12).

1. Turn the unit off, remove the engine key, and disconnect the spark plug wire.
2. To **DISENGAGE** the traction drive lock, insert the traction lock pin through the outer hole in the axle. (See Figure 11).
3. To **ENGAGE** the traction drive lock, insert the pin through the hub and axle (See Figure 12). If the hole in the hub is not aligned with the inner hole in the axle, push the snowthrower until the holes align and install the traction lock pin.

NOTE: When snowthrowing with the full width of the auger, for best drive performance engage both wheels. For easier turning when not using the full width of the auger, engage one wheel and use the engaged side as the snow contact side for the auger.

AFTER EACH USE

Normal use of the snowthrower may result in a build-up of packed snow in and around the starter cord housing and around engine controls. Heat from the engine will usually prevent the snow from freezing solid while the unit is running, but after the engine is shut down, some snow may continue melting from engine heat, and later freeze around some moving parts as the unit cools.

After each period of use, follow these steps to prevent freeze-up caused by ice formation in and around the engine controls and external parts.

1. Before shutting off the engine, pull the starter rope out 2 - 3 times, and allow it to rewind slowly. This will help clear packed snow from the starter cord area. Allow the engine to run for several minutes.
2. Stop the engine by moving the throttle lever (See Figure 8) down, or by pulling out the engine key.
3. Disconnect the spark plug wire, and position it away from the spark plug.
4. Brush snow and ice from the snowthrower. Be sure to clear engine and snowthrower controls, discharge chute, worm and chute rod gears, clutch cable areas, and anywhere else snow has accumulated.
5. Always remove the engine key and store in a safe place to prevent unauthorized use.
6. If the snowthrower is kept in a cold shelter, fill the fuel tank to prevent condensation. Do not store near sparks or flame.

Note: The engine owner's manual contains further information on preventing ice formation and freeze-up.

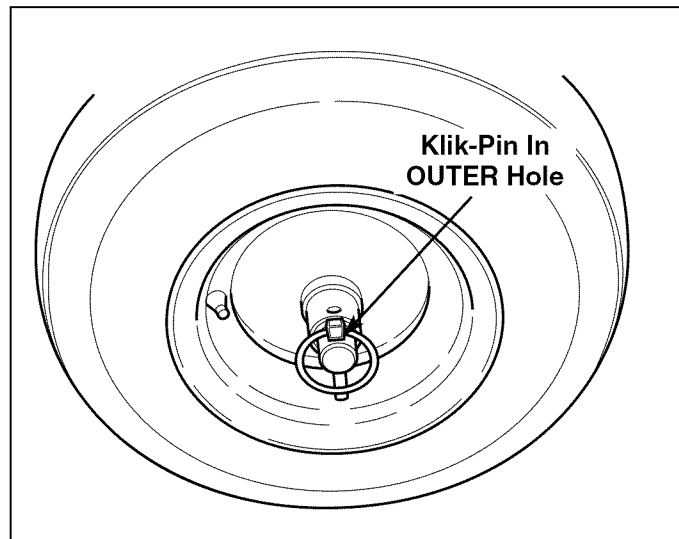

Figure 11. Traction Drive Lock - Disengaged

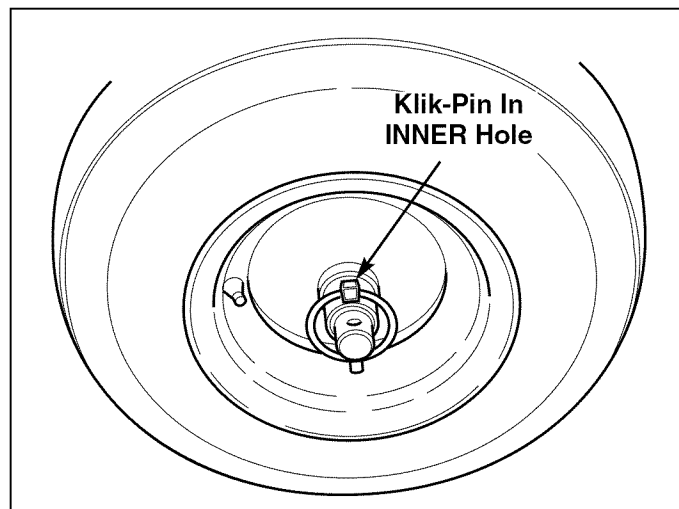

Figure 12. Traction Drive Lock - Engaged

WARNING

Never store snowthrower, with gasoline in engine or fuel tank, in a heated shelter or in enclosed, poorly ventilated enclosures. Gasoline fumes may reach an open flame, spark or pilot light (such as a furnace, water heater, clothes dryer, etc.) and cause an explosion.

Handle gasoline carefully. It is highly flammable and careless use can result in serious fire damage to people and property.

Drain fuel into an approved container outdoors away from open flame or sparks.

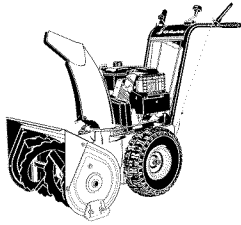

Regular Maintenance

MAINTENANCE SCHEDULE

MAINTENANCE REQUIRED	FREQUENCY	NOTES
Check auger gear case lubrication.**	25 Hours	Benalene 900 Grease
Lubricate snowthrower.	10 Hours	10W Oil and Grease
Check tire pressure.	Monthly	20 psi (1.37 bar)
Change engine oil.*+	50 Hours+	See Engine Manual
Clean or replace spark plug.+	Yearly	See Engine Manual
Check drive linkage/belt tension.	4-6 Hours	N/A
Lubricate Axle Shafts.	Yearly	Lithium Grease
Check / Lubricate Free-Hand Linkage.	10 Hours	10W Oil
Lubricate Auger Shaft. ***	10 Hours	Lithium Grease
* Change original oil after two hours of operation. ** Check oil level each fall and spring. ***Lubricate each fall and spring. + See your engine Owner's Manual.		

CHECKING TIRE PRESSURE

The air pressure in each tire (Figure 13) should be 20 psi (1,36 kPa) and should be equal for both tires for best performance. Be sure to keep caps on valves to prevent entry of debris into the valve stem when tires are filled.

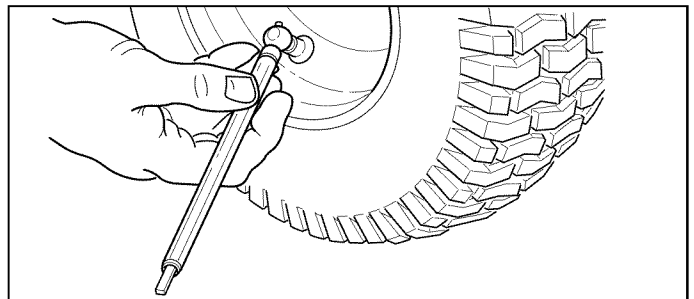

Figure 13. Checking Tire Pressure

CHECK AUGER GEAR CASE LUBRICATION

1. Place the snowthrower on a level surface.
2. Remove the pipe plug (Figure 14).
3. Check the lubricant level. It should be level with the lower edge of the plug opening. If not, add Benalene 900 grease (available from your dealer).
4. Re-install pipe plug, and tighten securely.

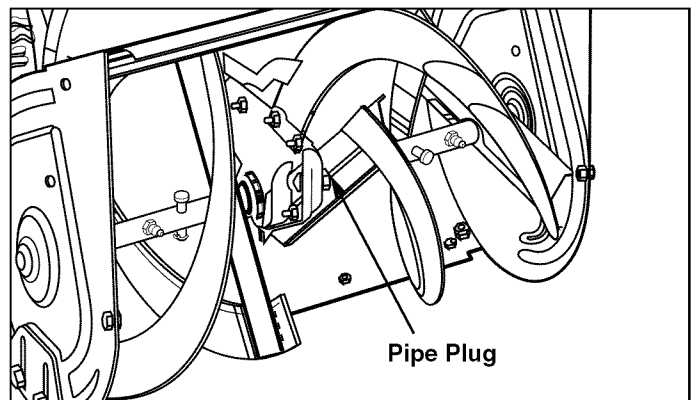

Figure 14. Checking Auger Gear Case Lubrication

Maintenance

LUBRICATION

IMPORTANT NOTE

It is very important that grease fittings on the auger shaft are lubricated regularly. If auger rusts to shaft, damage to worm gear may occur if shear pins do not break.

To prevent wheels rusting to axles, it is also necessary to remove the wheels and grease the axles regularly.

Remove wheels and grease axles once each year.

There are two grease fittings on the auger shaft. Wipe the fittings clean and apply grease, using a grease gun. Also apply grease on other points indicated.

Apply medium weight (10W) oil to points shown (See Figures 15 - 18).

Apply 5W-50 synthetic motor oil to the friction disc hex shaft (see Figure 15).

Generally, all moving metal parts should be oiled where contact is made with other parts. Keep oil and grease off belts, pulley grooves, drive disc, and friction disc.



LUBRICATION NOTES:

Grease locations indicated by grease gun symbol. Use grease fittings when present. Disassemble parts to apply grease to moving parts when grease fittings are not installed.



Oil locations indicated by oil can symbol. Do not allow oil to drip onto traction drive or friction disc.

CAUTION

In order to keep the free-hand controls disengaging properly when released, it is important to oil the free-hand controls every 10 hours.

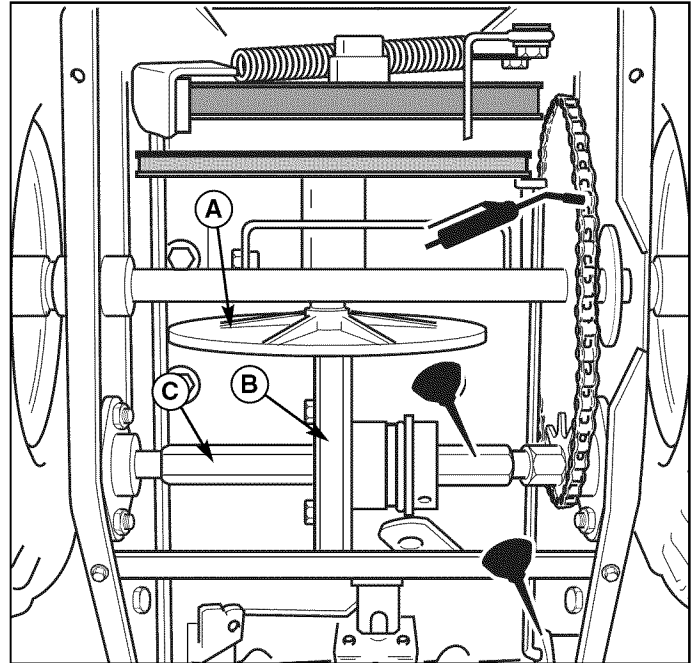

Figure 15. Drive Area Lubrication Points (Bottom Cover Removed)

- A. Drive Disc
- B. Friction Disc
- C. Hex Shaft

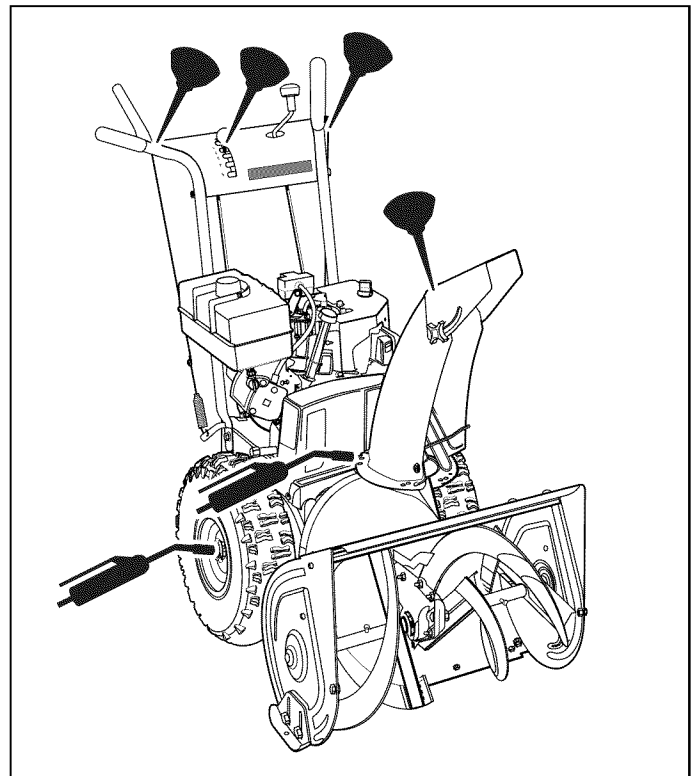

Figure 16. Snowthrower General Lubrication Points

LUBRICATION CHECK / LUBRICATE FREE-HAND LINKAGE

Check the function of the Free-Hand controls: the controls should function as described in the CONTROLS section. **It is critical for the safe operation of the unit that the controls disengage when released.**

If the controls do not function properly, lubricate them. If lubrication does not rectify the problem, see your dealer. Under no circumstances should the unit be used if the controls are not functioning properly.

IMPORTANT NOTE

It is very important that grease fittings on the auger shaft are lubricated regularly. If auger rusts to shaft, damage to worm gear may occur if shear pins do not break.

LUBRICATING THE AUGER SHAFT & ASSEMBLY

1. Remove cotter pin (C, Figure 18) and shear pin (B).
2. Use a grease gun and squirt several shots of grease into grease fitting (A).
3. Rotate auger assembly (D) several times to distribute the grease evenly. Repeat step 2.
4. Reinstall shear pin (B) and cotter pin (C).
5. Repeat procedure for other side.

STORAGE

⚠ WARNING

Never store the unit (with fuel) in an enclosed, poorly ventilated structure. Fuel vapors can travel to an ignition source (such as a furnace, water heater, etc.) and cause an explosion.

Fuel vapor is also toxic to humans and animals.

Before you store your unit for the off-season, read the Maintenance and Storage instructions in the Safety Rules section, then perform the following steps:

- Disengage the PTO, set the parking brake, and remove the key.
- Perform engine maintenance and storage measures listed in the engine owner's manual. This includes draining the fuel system, or adding stabilizer to the fuel (do not store a fueled unit in an enclosed structure - see warning).

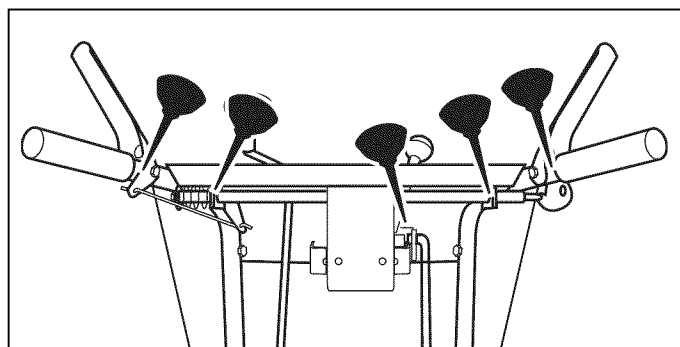

Figure 17. Lubricate Free Hand Control

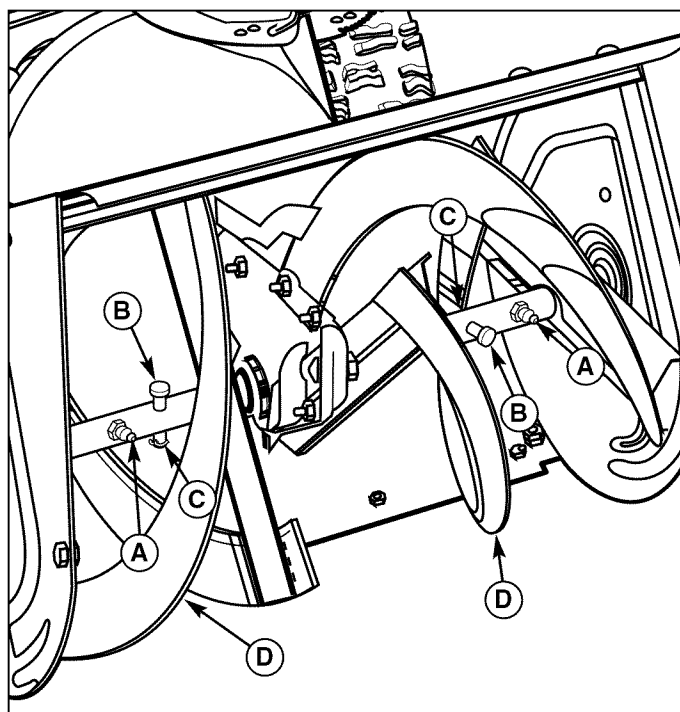
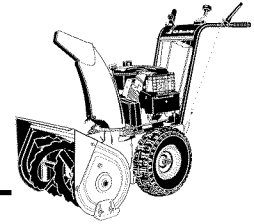

Figure 18. Checking Auger Gear Case Lubrication
 A. Grease Fittings C. Cotter Pins
 B. Shear Pins D. Auger Assembly

Before starting the unit after it has been stored:

- Check all fluid levels. Check all maintenance items.
- Perform all recommended checks and procedures found in the engine owner's manual.
- Allow the engine to warm up for several minutes before use.

Troubleshooting, Adjustment, & Service



TROUBLESHOOTING

This section provides troubleshooting and service instructions. Locate the problem and check the possible cause/remedy in the order listed.

Also, refer to the engine manufacturer's Owner's Manual for additional information.

For problems not covered here, contact your local dealer.

WARNING

Before performing any adjustment or service to snowthrower, stop the engine and wait for moving parts to stop. Remove the key. To prevent accidental starting, disconnect the spark plug wire and fasten away from the plug.

PROBLEM	POSSIBLE CAUSE	REMEDY
Engine fails to start.	<ol style="list-style-type: none"> 1. Key is OFF. 2. Failure to prime cold engine 3. Fuel valve is in CLOSED position. 4. Out of fuel. 5. Choke OFF - cold engine. 6. Engine flooded. 7. Spark plug not sparking. 8. Water in fuel, or old fuel. 	<ol style="list-style-type: none"> 1. Push key in to the ON position. 2. Press Primer Button twice and restart. 3. Turn valve to OPEN position. 4. Fill fuel tank. 5. Turn choke to ON, set throttle to FAST. 6. Turn choke to OFF; try starting. 7. Check gap. Gap plug, clean electrode, or replace plug as necessary. 8. Drain tank (Dispose of fuel at an authorized hazardous waste facility). Fill with fresh fuel.
Engine starts hard or runs poorly.	<ol style="list-style-type: none"> 1. Fuel mixture too rich. 2. Carburetor adjusted incorrectly. 3. Spark plug faulty, fouled, or gapped improperly. 4. Fuel cap vent is blocked. 	<ol style="list-style-type: none"> 1. Move choke to OFF position. 2. See your dealer for adjustments. 3. Clean and gap, or replace. 4. Clear vent.
Auger does not rotate.	<ol style="list-style-type: none"> 1. Auger control not engaged. 2. Foreign matter blocking auger. 3. Auger drive clutch cable slack. 4. Auger drive belt slipping. 5. Broken belt. 6. Shear pin broken. 	<ol style="list-style-type: none"> 1. Engage auger control. 2. STOP engine and REMOVE the key. DISCONNECT the spark plug wire. Clear auger using clean-out tool. See warning in SAFETY RULES. 3. Tighten to remove slack. See auger clutch cable adjustment. 4. Check auger drive belt adjustment. 5. Replace belt. 6. Replace shear pin.

PROBLEM	POSSIBLE CAUSE	REMEDY
Auger rotates, but snow is not thrown far enough	<ol style="list-style-type: none"> 1. Chute deflector too low. 2. Engine speed too slow. 3. Ground speed too fast. 4. Snowthrower discharge chute clogged. 5. Auger belt loose or worn. 	<ol style="list-style-type: none"> 1. Adjust deflector as necessary. 2. Set speed to full throttle. 3. Use slower speed selector setting. 4. STOP engine and REMOVE the key. DISCONNECT the spark plug wire. Clear auger using clean-out tool. See warning in SAFETY RULES. 5. Check auger drive belt adjustment
Scraper bar does not clean hard surface.	<ol style="list-style-type: none"> 1. Scraper bar height improperly adjusted. 	<ol style="list-style-type: none"> 1. RAISE skid shoes LOWER scraper bar (later models)
Scraper bar picks up and throws stones on gravel drive.	<ol style="list-style-type: none"> 1. Scraper bar height improperly adjusted. 	<ol style="list-style-type: none"> 1. LOWER skid shoes RAISE scraper bar (later models)
Poor traction	<ol style="list-style-type: none"> 1. Tires slipping. 	<ol style="list-style-type: none"> 1. Check tire pressure and tread.
Auger does not stop when auger lever is released	<ol style="list-style-type: none"> 1. Auger clutch cable too tight or bent. 2. Auger drive belt out of adjustment. 3. Auger belt guide out of adjustment. 4. Free hand control not releasing. 	<ol style="list-style-type: none"> 1. Loosen or straighten clutch cable. 2. Adjust auger belt. 3. Adjust auger belt guide. 4. Lubricate free hand linkage.
Snowthrower does not stop when drive lever is released	<ol style="list-style-type: none"> 1. Traction drive clutch cable bent or too tight. 	<ol style="list-style-type: none"> 1. Loosen cable to remove slack or replace. See adjustment procedure.
Snowthrower does not drive when drive lever is engaged.	<ol style="list-style-type: none"> 1. Traction drive clutch cable loose. 2. Drive belt loose, broken, or stretched. 3. Drive roller chain damaged. 4. Traction lock pins in free-wheeling position (OUTER hole). 5. Friction disc worn. 	<ol style="list-style-type: none"> 1. Tighten to remove slack. See adjustment procedure. 2. Replace drive belt. 3. Replace chain. 4. Change traction lock pins to INNER hole to engage traction drive. 5. Replace disc (see your dealer).
Discharge control is difficult to operate.	<ol style="list-style-type: none"> 1. Gearing needs lubrication 2. Worm gear not adjusted properly. 3. Control rod gears misaligned. 4. Pin connecting control shaft broken. 	<ol style="list-style-type: none"> 1. Oil or grease as required. 2. Adjust worm gear. See adjustment procedure. 3. Adjust gear bracket. See adjustment procedure. 4. Replace pin.
Snowthrower veers to one side.	<ol style="list-style-type: none"> 1. Tire pressure not equal. 2. One wheel is set in free-wheeling mode. (Traction lock pin is in the OUTER hole). 	<ol style="list-style-type: none"> 1. Check tire pressure. 2. Make certain BOTH traction lock pins are in the INNER holes (to engage traction drive).
Excessive vibration.	<ol style="list-style-type: none"> 1. Loose parts or damaged auger. 	<ol style="list-style-type: none"> 1. STOP engine and REMOVE the key. DISCONNECT the spark plug wire. Tighten all hardware. Replace auger if necessary. If vibration continues, see your dealer.
Drive fails to move snowthrower at slow speeds.	<ol style="list-style-type: none"> 1. Traction drive out of adjustment. 	<ol style="list-style-type: none"> 1. Readjust drive, or shift speed selector setting up one speed faster.

Adjustments

SPEED SELECTOR PIVOT ADJUSTMENT

The speed selector is factory set for optimal performance at each forward and reverse speed setting. However, if drive system components have been replaced, adjustment may be necessary.

Adjust as follows:

1. Move the ground speed control (A, Figure 19) fully forward.
2. Loosen the hardware (B) securing the upper and lower shift rods.
3. Push the lower rod (C) down fully (into the housing).
4. Make sure the ground speed control (A) is in the full forward (5th gear) position. Pull the two rods apart and tighten the shift rod hardware (B).

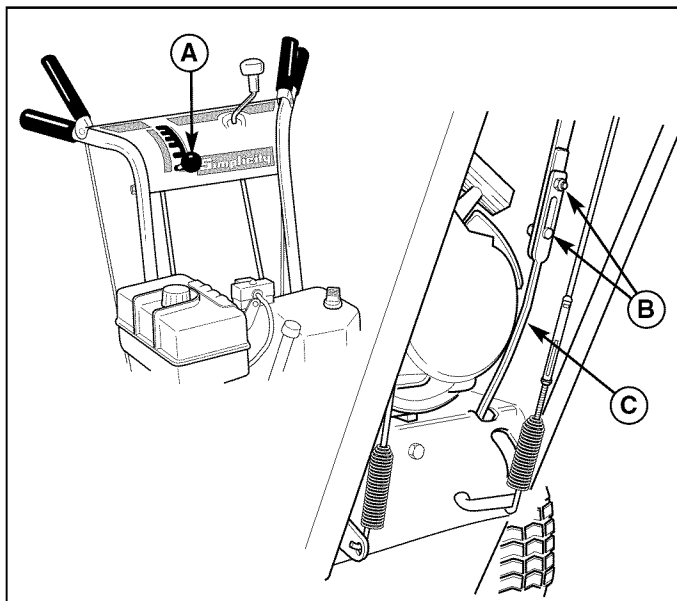

Figure 19. Speed Selector Linkage Adjustment

- A. Ground Speed Lever
- B. Shift Rod Hardware
- C. Lower Shift Rod

TRACTION DRIVE CLUTCH CABLE ADJUSTMENT

Initial Adjustment

The traction drive clutch cable should initially be adjusted so that there is no slack in the cable when moved slightly from side to side, but bellcrank arm remains in fully down position. To adjust tension on the cable:

1. Loosen adjustment hex nut (Figure 20) by holding the adjusting flats and turning adjustment hex nut.
2. Tighten adjustment screw by turning adjustment flats and holding screw. The adjustment screw is a phillips screw and the head can be held or turned by inserting a screwdriver through the traction drive clutch cable spring. **Tighten just until slack in cable is removed.**
3. Tighten hex nut securely. The unit should be able to be pushed forward and back freely.

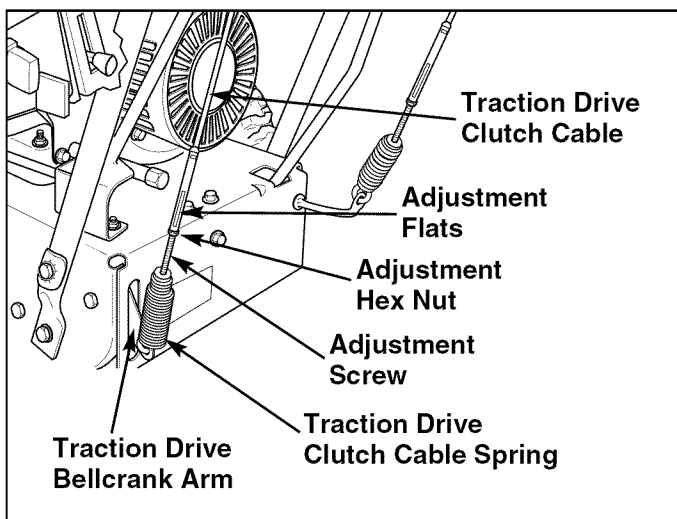

Figure 20. Traction Drive Clutch Cable Adjustment

⚠ WARNING

Do not over-tighten, as this may cause traction drive to engage without depressing the traction drive control (bellcrank arm must remain in down position).

Verify that the cables are not over-tightened: With speed selector in position 1 and traction drive control fully released, push snowthrower forward. The unit should move forward freely.

If unit does not move forward freely, the cable has been over-tightened. To remedy, loosen tension on clutch cable slightly, and recheck.

Run-In Adjustment

1. After 5 hours of use, check for proper adjustment. Readjust clutch cable if necessary by increasing tension on cable. A small amount of bellcrank arm movement is permissible if unit passes operating checks described in the Caution at left. **Optimal adjustment provides 3/16" clearance between traction drive disc and rubber ring on friction disc when drive lever is released** (see Figure 15 for friction disk location).

MANUAL DISCHARGE CHUTE CONTROL LINKAGE ADJUSTMENT

Pinion Gear Adjustment

If the discharge chute is difficult to operate, first lubricate the pinion gear (A, Figure 21) and ring gear (F). If it is still difficult to operate, adjust as follows:

NOTE: If the discharge chute will not stay in position, adjust the pinion gear (A) closer to the ring gear (F).

1. Loosen the nut (G, Figure 23) which holds the pinion gear bracket in the slotted hole.
2. If the pinion gear is too tight against the ring gear, move it away slightly and then retighten the nut.
3. Check the operation again.

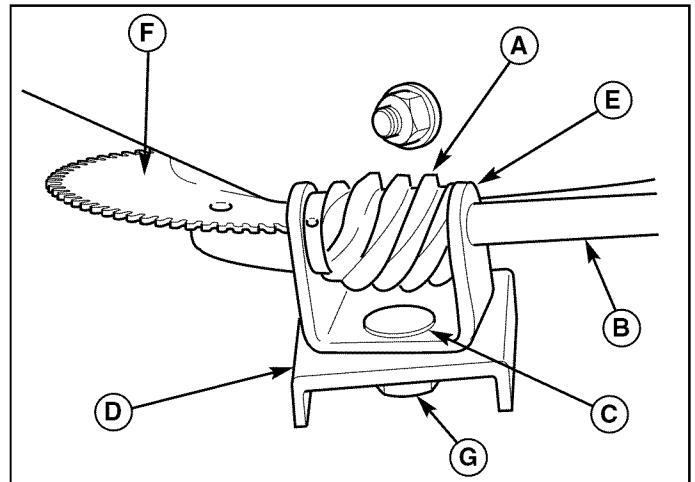

Figure 21. Discharge Control

- A. Pinion Gear
- B. Control Rod
- C. Carriage Bolt
- D. Slotted Bracket
- E. U-shaped Bracket
- F. Ring Gear
- G. Nut

CHUTE DIRECTION CONTROL ROD GEAR ADJUSTMENT

If the discharge chute becomes difficult to rotate or begins to operate erratically, the chute direction control rod gears may require adjustment:

1. Loosen the gear bracket mounting nuts (Figure 22).
2. Slide the gear bracket into the position that provides the best engagement between the gears.
3. Tighten the bracket mounting nuts, and check for smooth operation.
4. Readjust if necessary.
5. Lubricate the chute direction control rod gears with a medium weight (10W) oil.

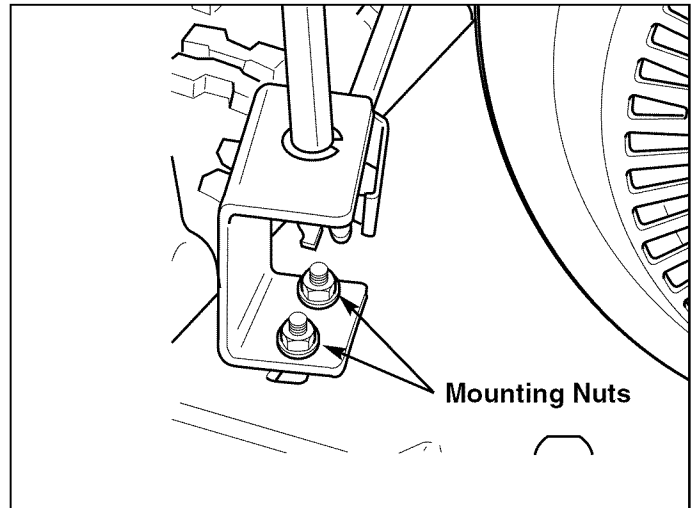

Figure 22. Chute Direction Gear Adjustments

Adjustments

AUGER DRIVE CLUTCH CABLE ADJUSTMENT

The auger drive clutch cable should be adjusted so that there is no slack in the cable when moved slightly from side to side. To adjust tension on the cable:

1. Loosen adjustment hex nut (Figure 23) by holding the adjusting flats and turning adjustment hex nut .
2. Tighten adjustment screw by turning adjustment flats and holding screw. The adjustment screw is a phillips screw and the head can be held or turned by inserting a screwdriver through the auger drive clutch cable spring. **Tighten just until slack in cable is removed.**

WARNING

Do not over-tighten, as this may lift the idler cable lever and cause auger drive to be engaged without depressing the Auger Control.

3. Tighten hex nut securely.
4. Start unit and check auger. Auger must not be engaged unless auger control is depressed.
5. With engine running, fully depress auger control, the auger should engage and run normally.
6. Release auger control. **Auger must stop within 5 seconds.**
7. If auger does not operate properly, stop engine and recheck clutch cable adjustments.
8. If clutch cable is properly adjusted, auger drive belt tension may require adjustment. See "Adjusting Auger Drive Belt" on next page.

DRIVE BELT ADJUSTMENT

The snowthrower is equipped with two drive belts located just in front of the engine under the belt cover. Figure 24 shows both belts and idler pulleys. The belt nearest the engine is the unit traction drive (wheels) belt. The belt farthest from the engine is the auger/ impeller drive belt.

The traction drive belt has constant tension provided by a spring-loaded idler pulley arm, and is non-adjustable. This belt rotates whenever the engine is running, and provides power to the traction drive disc, which also rotates constantly while the engine is running.

The auger drive belt tension may be adjusted by moving the auger drive idler pulley. See "Adjusting Auger Drive Belt" on next page.

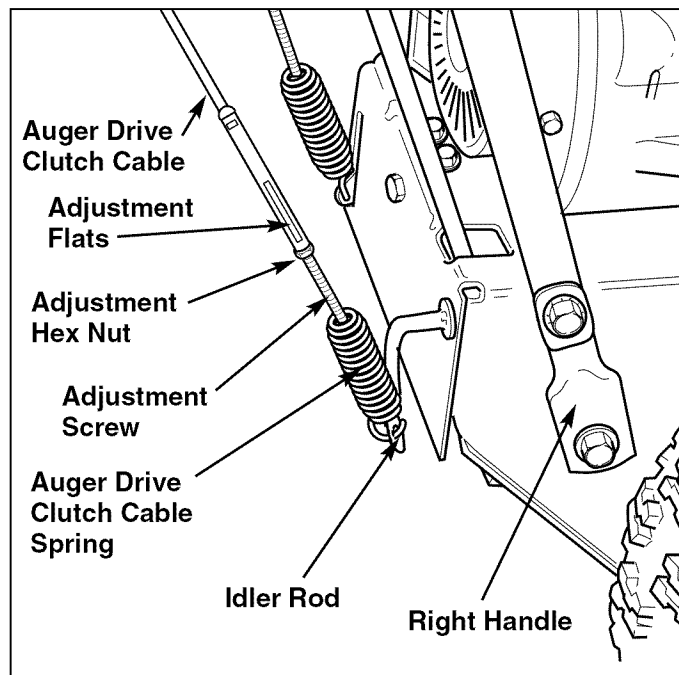

Figure 23. Auger Drive Clutch Cable Adjustment

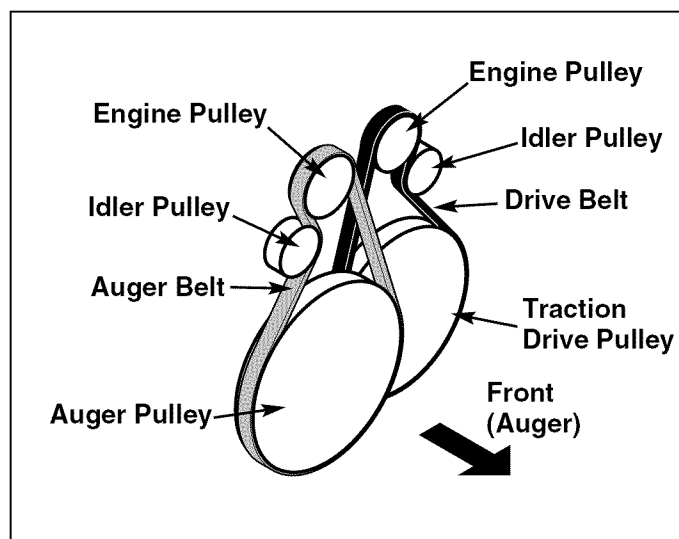

Figure 24. Drive Belt Paths

DRIVE BELT ADJUSTMENT (Continued)

If the auger drive slips (auger slows or doesn't rotate normally while blowing snow), or stays engaged when the control is disengaged — and the auger clutch cable has been properly adjusted — the auger drive belt may be out of adjustment.

⚠ WARNING

Auger must NOT rotate unless the Auger Control lever has been depressed. Proper Auger Drive Belt adjustments stop the auger within 5 seconds after the Auger Control is disengaged.

Checking Auger Belt & Belt Guide Adjustments

1. Insert the engine key and start the snowthrower.
2. Engage and disengage the auger control a series of ten times, checking that the auger comes to a complete stop within 5 seconds after the control is disengaged each time.
3. If the auger comes to a complete stop each time within 5 seconds, the adjustment is correct. If the auger does NOT come to a complete stop within the necessary 5 seconds, the adjustment is incorrect: readjusting the auger belt & belt guide according to the procedures below.

Adjusting Auger Drive Belt

1. Make certain that the snowthrower is off, the engine key has been removed, and the spark plug disconnected.
2. Check that there is no slack in the auger drive clutch cable (see Figure 26). If there is, follow the auger drive clutch cable Adjustment procedure on page 24.
3. Measure the length of the auger drive clutch spring (Figure 26).
4. Fully depress the auger control and measure the expanded length of the spring.
The spring should expand $19/64''-5/16''$. If the spring deflection is less than $19/64''-5/16''$ the auger idler pulley must be adjusted. Proceed to step 5.
5. Loosen the belt cover screws and remove the belt cover (Figure 25)
6. Loosen the adjustment bolt (see Figure 27) and move the auger idler pulley.
7. Tighten the adjustment bolt and repeat steps 3-4.
8. Test run the unit. The auger must NOT rotate unless the auger control lever has been depressed. Proper auger drive belt adjustments stop the auger within 5 seconds after the auger control is disengaged. If the auger drive fails either of these tests, repeat the

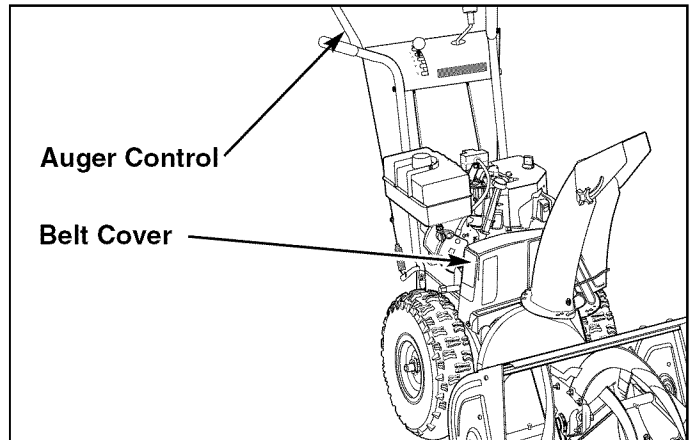

Figure 25. Auger Control and Belt Cover Location

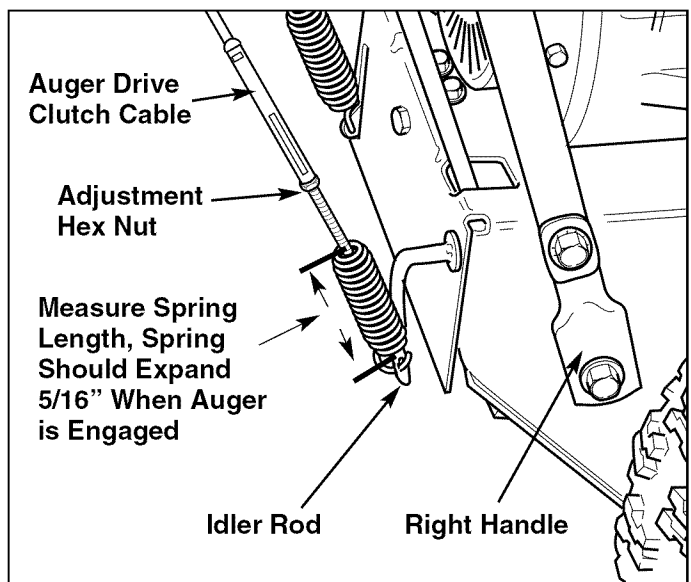

Figure 26. Auger Drive Clutch Cable

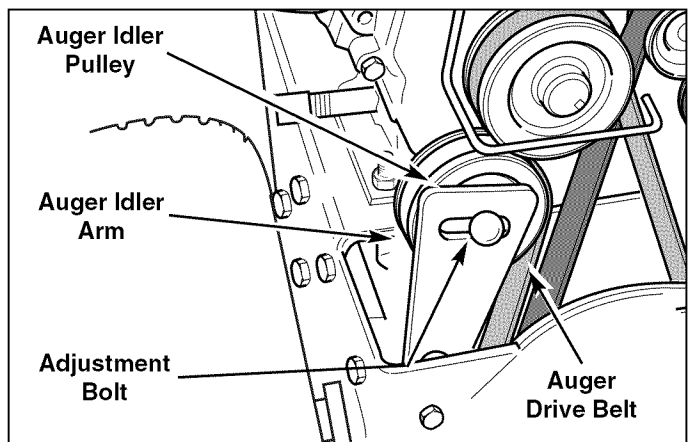

Figure 27. Auger Drive Belt, Guide and Pulley

adjustment procedures.

9. After adjusting the auger drive belt, the auger belt guide **MUST BE** adjusted according to the *Adjusting Auger Belt Guide* procedure which follows.

Adjustments & Service

DRIVE BELT ADJUSTMENT (Continued)

Adjusting Auger Belt Guide

1. With the auger control still fully depressed, adjust the auger belt guide(s) so that there is a 1/64" gap (1/32" Maximum) between the guide and the belt (Figures 28, 28a), making certain the guide is NOT putting pressure on the belt.
2. Making certain the auger belt guide does NOT move while doing so, tighten the auger belt guide screw (Figures 28, 28a) to secure the guide.
3. Check the adjustment on the auger belt guide(s) (Figures 28, 28a) to make certain that the gap between the belt and the belt guide is correct.
4. Disengage the auger control by removing the cardboard tube (or other means used to temporarily secure the control.)
5. Test the unit by following the steps under the "Checking Auger Belt & Belt Guide Adjustments" above.

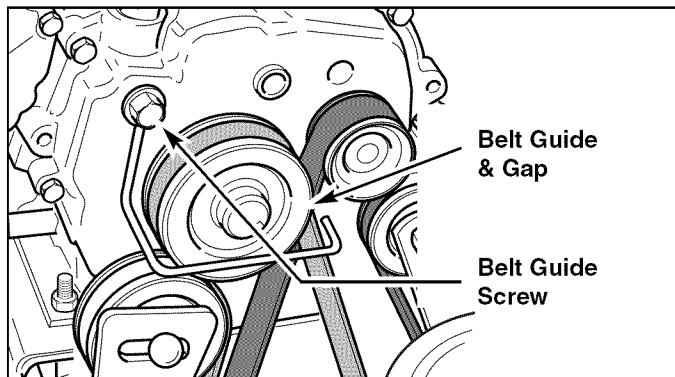

Figure 28. Auger Belt Guide Adjustment (Earlier Models)

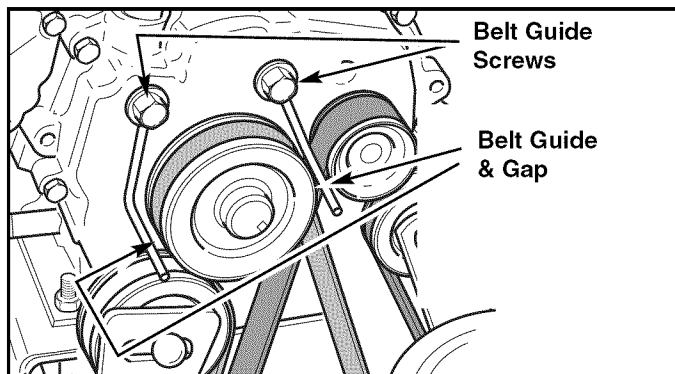

Figure 28a. Auger Belt Guide Adjustment (Later Models)

WARNING

Failure to properly adjust the Auger Belt Guide(s) may cause auger to rotate when Auger Control has not been depressed.

DRIVE BELT REPLACEMENT

The snowthrower has two drive belts, one for the traction drive—which transmits engine power to the wheels, and a second for the auger drive—which transmits engine power to the auger mechanism.

Each of these drive belts are of special construction and should be replaced only with genuine replacement belts which match the original equipment belts. These are available from your dealer.

Traction Drive Belt Replacement

1. Disconnect spark plug wire and fasten it away from the spark plug.
2. Remove belt cover.
3. Pull the traction drive belt idler pulley arm (See Figure 24) away from the belt to relieve tension, and slide the belt off the engine pulley.
4. Slip the belt off from around the traction pulley (See Figure 29) and pull the belt out of the unit between the auger pulley and the traction pulley (the lower cover need not be removed for this step).

WARNING

Snowthrower must move only when the traction Drive Control is depressed, and must stop when the lever is released (disengaged).

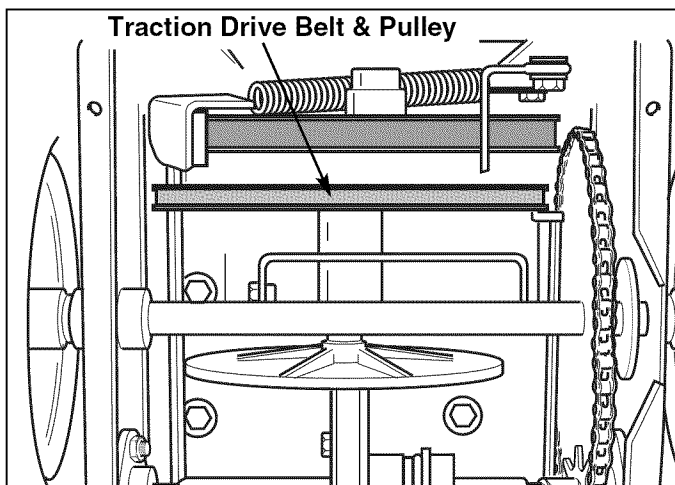

Figure 29. Traction Drive Pulley (Lower Cover Removed For Clarity)

DRIVE BELT REPLACEMENT (Cont.)

Traction Drive Belt Replacement (Cont.)

5. Reverse the procedure to install the new belt. Be sure there are no twists in the belt, and that the belt is properly seated in the pulley grooves.
6. Replace the belt cover.
7. Start the unit, and check the traction drive for proper operation. See "Traction Clutch Cable Adjustment" for adjustment procedures.

Auger Drive Belt Replacement

1. Remove gas from fuel tank and run engine until it stops running from lack of fuel.
2. Disconnect spark plug wire and fasten it away from the spark plug.
3. Remove belt cover (See Figure 25).
4. Loosen auger belt guide and slide belt off engine pulley and away from idler pulley. (See Figure 28).
5. Clamp or tie auger control lever to handle in the fully depressed position to release all tension on the auger pulley brake pad, and provide clearance for belt removal.
6. Tilt unit forward and rest on auger housing.
7. Remove lower cover.
8. Loosen hex screw securing belt stop (Figure 30), and pivot the belt stop away from the pulley to permit removal of belt.
9. Pull the belt out of the unit, and install the new belt on the auger drive pulley.
10. Position belt stop to provide 1/8" clearance between stop and belt, and and tighten securely.
11. Replace lower cover.
12. Return unit to normal upright operating position.
13. Release auger control.
14. Install auger belt over engine pulley.
15. Adjust auger belt stop as described under ADJUSTING BELT GUIDES.
16. Install belt cover.
17. Connect spark plug wire and fill fuel tank.
18. Start unit and check auger for proper operation. See "Auger Drive Clutch Cable Adjustment" for adjustment procedures if additional adjustment is necessary.

⚠ WARNING

Auger must NOT rotate unless the Auger Control lever has been depressed, and auger must stop within 5 seconds after Auger Control lever has been released.

⚠ WARNING

Do not go near the discharge chute or auger when the engine is running. Do not run the engine with any cover or guard removed.

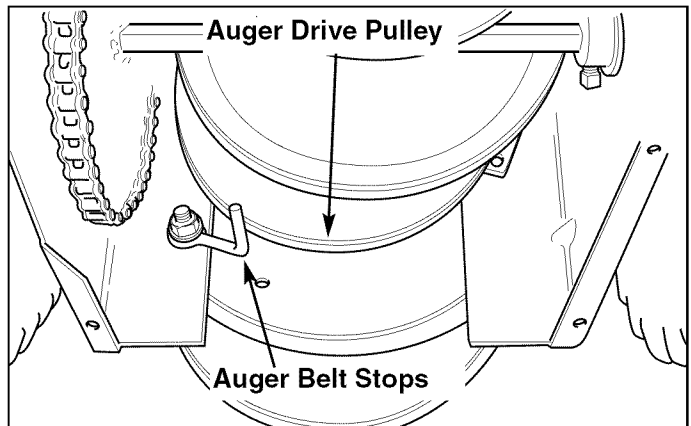

Figure 30. Auger Drive Pulley and Belt Stops

Service

ROLLER CHAIN REPLACEMENT

NOTE: This procedure does not apply to models that use an "endless" chain.

1. Remove gas from fuel tank and run engine until it stops running from lack of fuel.
2. Disconnect spark plug wire and fasten it away from the spark plug.
3. Tilt the snowthrower forward and carefully rest unit on the auger end.
4. Rotate the wheel to locate the roller chain master link.
5. Remove the keeper link, master link and chain.
6. Install new chain and master link as shown in Figure 31.
7. Return snowthrower to upright operating position.
8. Connect spark plug wire and fill fuel tank.

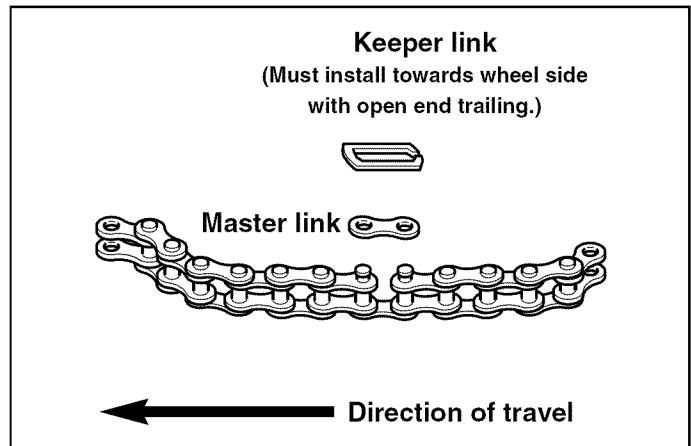

Figure 31. Roller Chain Master Link

SHEAR PIN REPLACEMENT

WARNING

Do not go near the discharge chute or auger when the engine is running. Do not run the engine with any cover or guard removed.

Under most circumstances, if the auger strikes an object which could cause damage to the unit, the shear pin will break. (This protects the gear box and other parts from damage.)

The shear pins are located on the auger shaft as shown in Figure 32. To replace the shear pins, tap out broken pin with a pin punch, and install a new shear pin and cotter pin. Spread the legs of the new cotter pin fully. **Do NOT replace shear pins with anything other than the correct grade replacement shear pin.** See the REPLACEMENT PARTS section at the back of this manual for the correct part numbers. (Use of bolts, screws or a harder shear pin will lead to damaged equipment.)

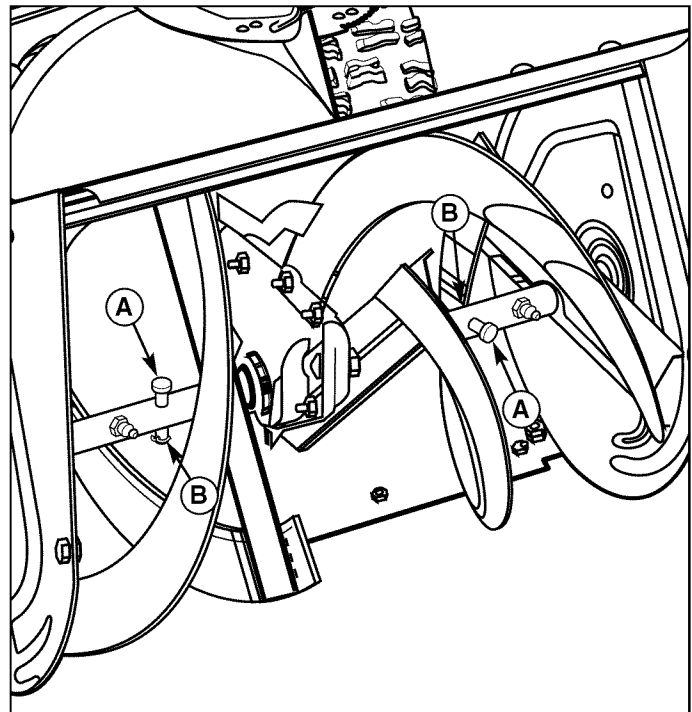

Figure 32. Shear Pin Replacement
A. Shear Pin B. Cotter Pin

Specifications

NOTE: Specifications are correct at time of printing and are subject to change without notice.

** Actual sustained equipment horsepower will likely be lower due to operating limitations and environmental factors.*

ENGINE:

5 HP* Tecumseh

Make Tecumseh
Model Snow King
Horsepower 5 HP @ 3600 rpm
Displacement 11.88 Cu. in (195 cc)
Oil Capacity See Engine Owner's Manual

7.5 HP* Briggs & Stratton

Make Briggs & Stratton
Model Intek Snow
Horsepower 7.5 HP @ 3600 rpm
Displacement 12.6 Cu. in (206 cc)
Oil Capacity 20 oz. (.59 L)

8 HP* Briggs & Stratton

Make Briggs & Stratton
Model Intek Snow
Horsepower 8 HP @ 3600 rpm
Displacement 18.6 Cu. in (305 cc)
Oil Capacity 28 oz. (.84 L)

8.5 HP* Briggs & Stratton

Make Briggs & Stratton
Model Intek Snow
Horsepower 8.5 HP @ 3600 rpm
Displacement 18.6 Cu. in (305 cc)
Oil Capacity 28 oz. (.84 L)

CHASSIS:

Wheels Inflation Pressure: 20 psi (1,37 bar)
Spout Rotation 190 Degrees
Impeller 10" (25.4 cm) 4 Blade Ribbon Flighted Steel
Drive System Friction Disc, 5 Forward Speeds, 2 Reverse

DIMENSIONS

Effective Clearing Width
 -555, I5225, 22" (61 cm)
 7555, I75225
 -860, I8245, 24" (65 cm)
 8560, I85245

Length
 -555, I5225, 51" (132 cm)
 7555, I75225,
 860, I8245,
 8560, I85245

Height
 -555, I5225, 43" (109cm)
 7555, I75225,
 860, I8245,
 8560, I85245

Weight
 -555, I5225, 158 lbs. (72 kg)
 7555, I75225
 -860, I8245, 178 lbs. (80 kg)
 8560, I85245

CE COMPLIANCE SPECIFICATIONS

Model	RPM's (Governed)	Kilowatts (kW) (@ Governed RPM's)	Unit Mass (kg)	Sound Power (LWA) (dBA)	Sound Pressure (LPA) (dBA)	Vibration at Handle (m/s ²)
555	3600	3.73	72	105	90	33.9
EI5225	3600	3.73	72	105	90	32.4
860M	3600	5.97	80	105	90	40.9
EI8245	3600	5.97	80	105	90	30.0
7555EX	3600	5.59	72	105	90	33.9
EI7225	3600	5.59	72	105	90	32.4
EI85245	3600	6.34	80	105	90	30.0
8560EX	3600	6.34	80	105	90	40.9

Replacement Parts & Accessories

REPLACEMENT PARTS

Replacement parts are available from your authorized dealer. Always use genuine Simplicity / Snapper Service Parts.

MAINTENANCE ITEMS

Many convenient and helpful service and maintenance items are available from your authorized dealer. Some of these items include:

Engine Oil	Tire Sealant
Touch-Up Paint	Degrimer/Degreaser
Grease Gun Kit	Gas Stabilizer
8 oz. Grease Tube	

TECHNICAL MANUALS

Additional copies of this manual are available, as well as fully illustrated parts lists. These manuals show all of the product's components in exploded views (3D illustrations which show the relationship of parts and how they go together) as well as part numbers and quantities used. Important assembly notes and and torque values are also included.

For applicable manuals currently available for your model, contact our Customer Publications Department at 262-284-8519 (Simplicity Manufacturing Inc.) or 1-866-313-6682 (Snapper). Have the information listed in the box below available when phoning in your request. Technical manuals can be downloaded from www.simplicitymfg.com or www.snapper.com

Model:	_____
Mfg. No.:	_____
Your Name:	_____
Address:	_____
City, State, Zip:	_____
Visa/Mastercard No.:	_____
Card Expiration Date:	_____



Simplicity[®]

MANUFACTURING, INC.
500 N Spring Street / PO Box 997
Port Washington, WI 53074-0997

www.simplicitymfg.com

© Copyright 2005, Simplicity Manufacturing, Inc.
All Rights Reserved. Printed in USA.

