

PRODUCT MODEL NUMBERS

| | | |
|-----------|-----------|-----------|
| GGQ9858JQ | LGQ9508KQ | LGR5644JQ |
| GGQ9858JT | LGQ9557KQ | LGR5644JT |
| GGW9878JQ | LGQ9557KT | LGR5700KQ |
| GGW9878JT | LGQ9558KQ | LGR5700KT |
| LGB6000KQ | LQG9558KT | LGR7620KQ |
| LGB6200KQ | LGR3624JQ | LGR7648KQ |
| LGB6400KQ | LGR3634JW | LGR7648KT |
| LGQ7030KQ | LGR5620KQ | |
| LGQ8100KQ | LGR5636KQ | |
| LGQ8100KT | LGR5636KT | |

Gas supply: Dryer is equipped for use with NATURAL gas. Dryer can be converted to L.P. gas. When rigid pipe is used it should be 1/2 inch IPS. When acceptable to the gas supplier and local codes, 3/8-inch approved tubing may be used for lengths under 20 feet. For lengths over 20 feet, larger tubing should be used. Pipe-joint compounds resistant to the action of L.P. gas must be used. If local codes permit, it is recommended that new flexible metal tubing, design-certified by AGA or CSA, be used for connecting the appliance to the rigid gas supply line. (The gas pipe which extends through the lower rear of the appliance has 3/8-inch male pipe thread.) An individual manual shutoff valve must be installed within 6 feet of the dryer in accordance with the National Fuel Gas Code ANSI Z223.1.

Electrical: 120-volt, 60-Hz, AC-only, 15- or 20-amp. electrical supply. Use copper wire only. A time-delay fuse or circuit breaker and separate circuit is recommended.

Exhaust venting: Exhaust your dryer to the outside. four-inch diameter vent is required. Rigid or flexible metal exhaust vent must be used. Do Not use plastic or metal foil vent. Exhaust outlet hood must be at least 12 inches from the ground or any object that may be in the path of the exhaust.

OVERALL DIMENSIONS

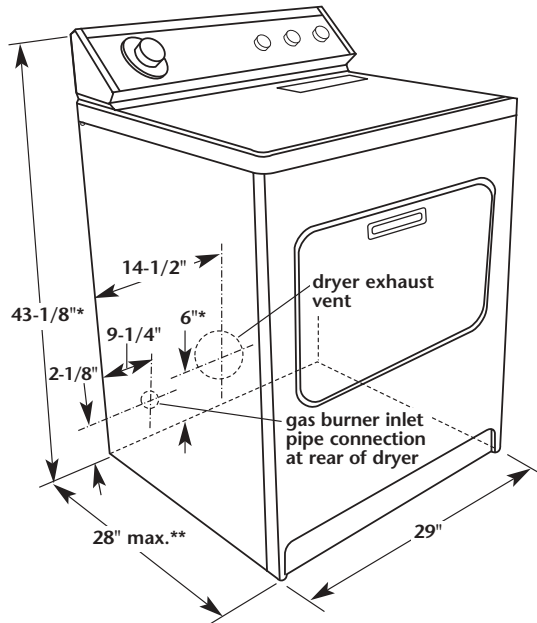

* from floor with dryer feet extended 1 inch
 **Most installations will require at least 5-inch clearance behind the dryer for the dryer vent.

RECESSED AREA AND CLOSET INSTALLATION

Closet confined area

If a closet door is installed: The minimum unobstructed air openings are required. Louvered doors with equivalent air openings are acceptable.

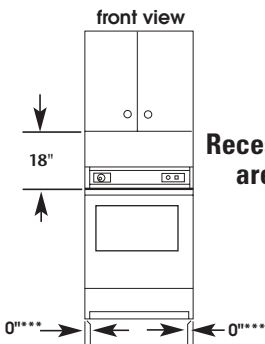

Recessed area

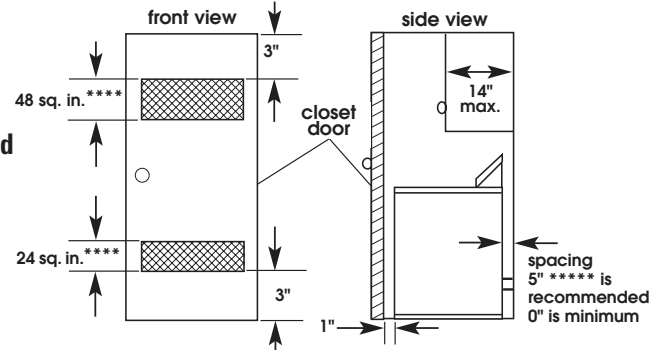

***Wall, door and floor molding may require additional spacing.

**** Minimum top and bottom air openings for closet door.
 *****External exhaust elbow requires additional space.

EXHAUST VENTING

Preferred

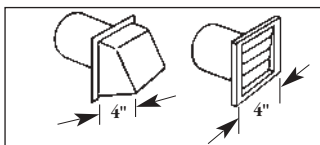

When you have a 4" hood

| Number of 90° elbows | Maximum length of 4" diameter metal vent | |
|----------------------|--|---------------------------|
| | Rigid | Flexible (fully extended) |
| 0 | 64 ft. | 36 ft. |
| 1 | 54 ft. | 31 ft. |
| 2 | 44 ft. | 27 ft. |
| 3 | 35 ft. | 25 ft. |
| 4 | 27 ft. | 23 ft. |

Acceptable

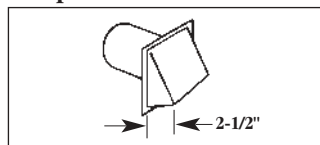

When you have a 2-1/2" hood

| Number of 90° elbows | Maximum length of 4" diameter metal vent | |
|----------------------|--|---------------------------|
| | Rigid | Flexible (fully extended) |
| 0 | 58 ft. | 28 ft. |
| 1 | 48 ft. | 23 ft. |
| 2 | 38 ft. | 19 ft. |
| 3 | 29 ft. | 17 ft. |
| 4 | 21 ft. | 15 ft. |

Select the route that will provide the straightest and most direct path outdoors. Plan the installation to use the fewest number of elbows and turns. Avoid making 90° turns.

When using elbows or making turns, allow as much room as possible. Bend flexible metal vent gradually to avoid kinking.

Determine vent length

1. See the exhaust vent length chart that matches your type hood for the maximum vent lengths you can use.

Do not use vent runs longer than specified in exhaust vent length charts.

2. Determine the number of elbows you will need.

3. In the column listing the type of metal vent you are using (rigid or flexible), find the maximum length of metal vent on the same line as the number of elbows.

The maximum length using a 2" x 6" rectangular vent with 2 elbows and a 2-1/2" exhaust hood is 8 ft.