

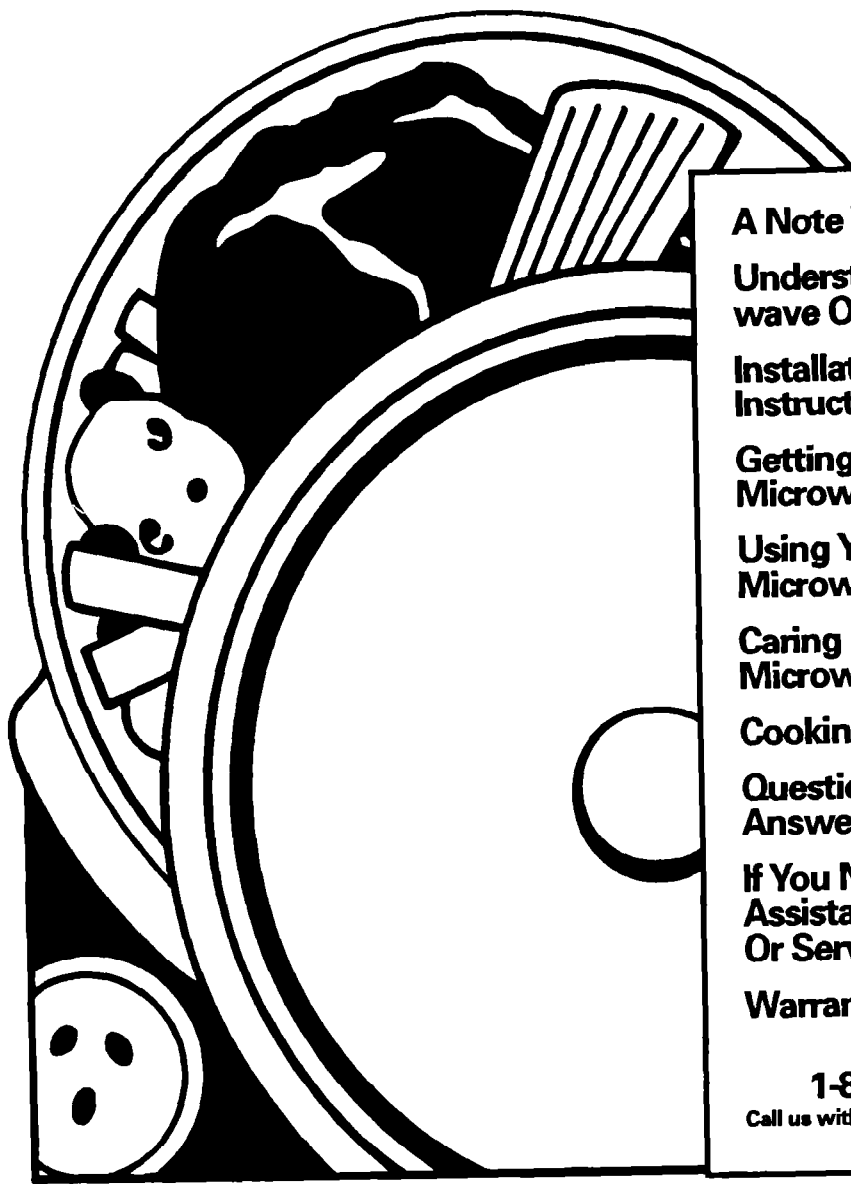

# Use And Care

## G U I D E



A Note To You	2
Understanding Microwave Oven Safety	3
Installation Instructions	8
Getting To Know Your Microwave Oven	10
Using Your Microwave Oven	17
Caring For Your Microwave Oven	36
Cooking Guide	37
Questions And Answers	41
If You Need Assistance Or Service	42
Warranty	44

**1-800-253-1301**  
Call us with questions or comments.

VIP™ MICROWAVE OVEN

MODELS MT2070XAB MT3090XAQ/B

6/93

# A Note To You

## **Thank you for buying a Whirlpool appliance.**

You have purchased a quality, *world-class* home appliance. Years of engineering experience have gone into its manufacturing. To ensure that you will enjoy many years of trouble-free operation, we have developed this Use and Care Guide. It is full of valuable information on how to operate and maintain your appliance properly and safely. Please read it carefully. Also, please complete and mail the Ownership Registration Card provided with your appliance. This will help us notify you about any new information on your appliance.

## **Your safety is important to us.**

This guide contains safety symbols and statements. Please pay special attention to these symbols and follow any instructions given. Here is a brief explanation of the use of each symbol.

### **⚠ WARNING**

This symbol will help alert you to such dangers as personal injury, burns, fire and electrical shock.

### **⚠ CAUTION**

This symbol will help you avoid actions which could cause product damage (scratches, dents, etc.) and damage to your personal property.

## **Our Consumer Assistance Center number, 1-800-253-1301, is toll-free, 24 hours a day.**

If you ever have a question concerning your appliance's operation, or if you need service, first see "If You Need Assistance Or Service" on page 42. If you need further help, feel free to call our Consumer Assistance Center. When calling, you will need to know your appliance's complete model number and serial number. You can find this information on the model and serial number plate (see diagram on page 12). For your convenience, we have included a handy place below for you to record these numbers, the purchase date from the sales slip and your dealer's name and telephone number. Keep this book and the sales slip together in a safe place for future reference.

Model Number \_\_\_\_\_

Dealer Name \_\_\_\_\_

Serial Number \_\_\_\_\_

Dealer Phone \_\_\_\_\_

Purchase Date \_\_\_\_\_

# Understanding Microwave Oven Safety

## IMPORTANT SAFETY INSTRUCTIONS

Microwave ovens have been thoroughly tested for safe and efficient operation. However, as with any appliance, there are special installation and safety precautions which must be followed to ensure safe and satisfactory operation and prevent damage to the unit.

### **⚠ WARNING**

To reduce the risk of burns, fire, electrical shock, injury to persons, exposure to excessive microwave energy, or damage when using the microwave oven, follow basic precautions, including the following:

- Read all instructions before using the microwave oven.
- Read and follow the specific "PRECAUTIONS TO AVOID POSSIBLE EXPOSURE TO EXCESSIVE MICROWAVE ENERGY" found on page 5.
- This appliance must be grounded. Connect only to properly grounded outlet. See "GROUNDING INSTRUCTIONS" found on page 9.
- Install or locate this appliance only in accordance with the provided Installation Instructions found on page 8.
- Some products such as whole eggs in the shell and sealed containers—for example, closed glass jars—may explode and should not be heated in this oven.
- Do not heat, store or use flammable materials in or near the oven. Fumes can create a fire hazard or explosion.
- Use this appliance only for its intended use as described in this manual. Do not use corrosive chemicals or vapors in this appliance. This type of oven is specifically designed to heat or cook food. It is not designed for industrial or laboratory use.
- As with any appliance, close supervision is necessary when used by children.
- Do not operate this appliance if it has a damaged cord or plug, if it is not working properly, or if it has been damaged or dropped. Electrical shock, fire or other hazards may result.
- This appliance should be serviced only by qualified service personnel. Call an authorized Whirlpool<sup>SM</sup> service company for examination, repair or adjustment.
- Do not cover or block any opening on the appliance. Fire may result.
- Do not store or use this appliance outdoors. Do not use this product near water—for example, near a kitchen sink, in a wet basement, or near a swimming pool, and the like.
- Do not immerse cord or plug in water.
- Keep cord away from heated surfaces.
- Do not let cord hang over edge of table or counter.
- See door surface and interior cleaning instructions on page 36.
- To reduce the risk of fire in the oven cavity:
  - Do not overcook food. Carefully attend appliance if paper, plastic, or other combustible materials are placed inside the oven to facilitate cooking. Paper can char or burn, and some plastics can melt if used when heating foods.
  - Do not deep fry in oven. Microwavable utensils are not suitable and it is difficult to maintain appropriate deep frying temperatures.

continued on next page

## UNDERSTANDING MICROWAVE OVEN SAFETY

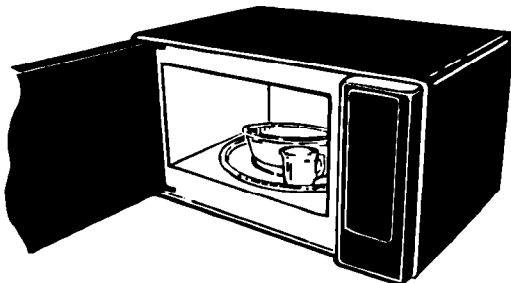

- **Test dinnerware or cookware before using.** To test a dish for safe use, put it into the oven with a cup of water beside it. Cook on 100% Cook Power for one minute. **If the dish gets hot and water stays cool, do not use it.** Some dishes (melamine, some ceramic dinnerware, etc.) absorb microwave energy, becoming too hot to handle and slowing cooking times. Cooking in metal containers not designed for microwave use can damage the oven, as can containers with hidden metal (twist-ties, foil lining, staples, metallic glaze or trim).
- Remove wire twist-ties from paper or plastic bags before placing bag in oven.

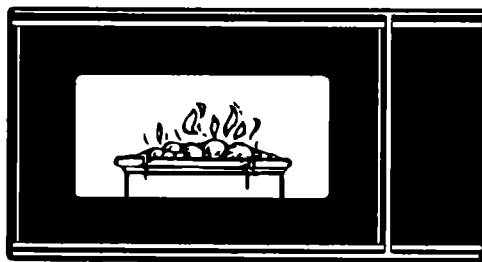

- If materials inside the oven should ignite, keep oven door closed, turn oven off, and disconnect the power cord or shut off power at the fuse or circuit breaker panel.

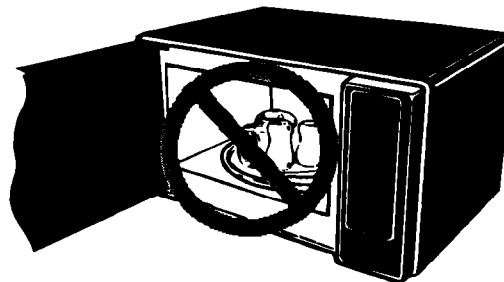

- Do not use the cavity for storage purposes. Do not leave paper products, cooking utensils, or food in the cavity when not in use.
  - Do not mount over a sink.
  - Do not store anything directly on top of the appliance when appliance is in operation.
- Read and follow "Operating Safety Precautions" starting on page 6.
  - 1. A short power-supply cord is provided to reduce the risks resulting from becoming entangled in or tripping over a longer cord.
  2. Longer cord sets or extension cords are available and may be used if care is exercised in their use.
  3. If a long cord or extension cord is used temporarily, (a) the marked electrical rating of the cord set or extension cord should be at least as great as the electrical rating of the appliance, (b) the extension cord must be a grounding-type, 3-wire cord that has a 3-blade grounding plug and a 3-slot receptacle that will accept the plug on the appliance, and (c) the longer cord should be arranged so that it will not drape over the countertop or tabletop where it can be pulled on by children or tripped over accidentally.
  4. A qualified electrician must install a properly grounded and polarized 3-prong receptacle near the appliance.

**– SAVE THESE INSTRUCTIONS –**

## **PRECAUTIONS TO AVOID POSSIBLE EXPOSURE TO EXCESSIVE MICROWAVE ENERGY...**

**Do not** attempt to operate this oven with the door open since open-door operation can result in harmful exposure to microwave energy. It is important not to defeat or tamper with the safety interlocks.

**Do not** place any object between the oven front face and the door or allow soil or cleaner residue to accumulate on sealing surfaces.

**Do not** operate the oven if it is damaged. It is particularly important that the oven door close properly and that there is no damage to the:

- (1) Door (bent),
- (2) Hinges and latches (broken or loosened),
- (3) Door seals and sealing surfaces.

**Do not** operate the microwave oven if the door window is broken.

The microwave oven should be checked for microwave leakage by qualified service personnel after a repair is made.

The oven should not be adjusted or repaired by anyone except properly qualified service personnel.

**Do not** operate the microwave oven with the outer cabinet removed.

## Operating safety precautions

### ⚠ WARNING

To reduce the risk of burns, fire, electrical shock, injury to persons, or damage when using the microwave oven, follow the precautions on pages 6-7.

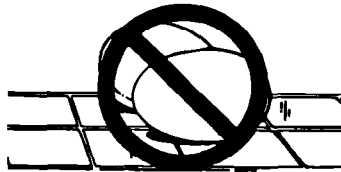

**Never cook or reheat a whole egg inside the shell.** Steam build-up in whole eggs may cause them to burst and burn you, and possibly damage the oven. **Slice** hard-boiled eggs before heating. In rare instances, poached eggs have been known to explode. **Cover** poached eggs and **allow** a standing time of one minute before cutting into them.



Stir before heating

**For best results, stir thick liquids several times before heating or reheating.** Liquids heated in certain containers (especially cylindrical containers) may become overheated. The liquid may splash out with a loud noise during or after heating or when adding ingredients (coffee, etc.) resulting in harm to the oven and possible personal injury.



**Never lean on the door or allow a child to swing on it when the door is open.** Injury could result.

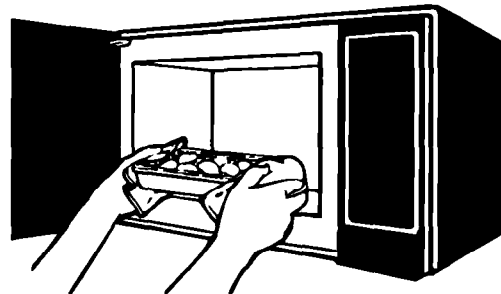

**Use hot pads.** Microwave energy does not heat containers, but the hot food does.

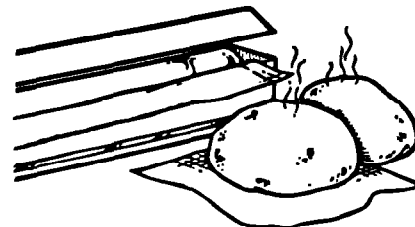

**Do not overcook potatoes.** Fire could result. At the end of the recommended cooking time, potatoes should be slightly firm because they will continue cooking during standing time. **After microwaving, wrap potatoes in foil and set aside for 5 minutes.** They will finish cooking while standing.

# UNDERSTANDING MICROWAVE OVEN SAFETY

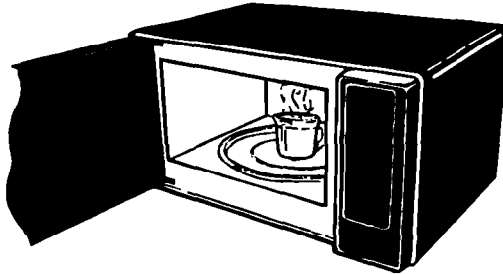

**Do not** start a microwave oven when it is empty. Product life may be shortened.

If you practice programming the oven, **put** a container of water in the oven.

It is normal for the oven door to look wavy after the oven has been running for a while.

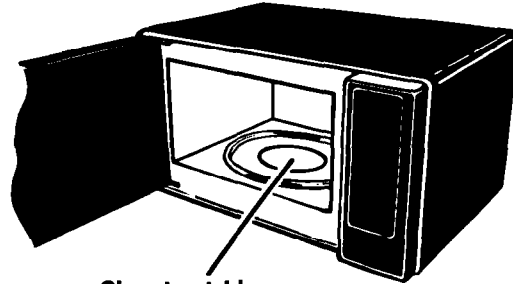

Glass turntable

**Do not** operate in the microwave mode unless the glass turntable is securely in place and can rotate freely. The turntable can rotate in either direction.

**Make sure** support base is all the way on the shaft in oven cavity floor. **Make sure** support rollers are completely inside center circle of turntable for proper rotation.

**Make sure** the glass turntable is correct-side up in oven. **Carefully place** cookware on glass turntable to avoid possible breakage.

**Handle glass turntable with care** when removing from oven to avoid possible breakage. If glass turntable cracks or breaks, contact your Whirlpool dealer for a replacement.

When you use a browning dish, the browning dish bottom must be at least  $\frac{3}{16}$  inch above the glass turntable. Follow directions supplied with browning dish.

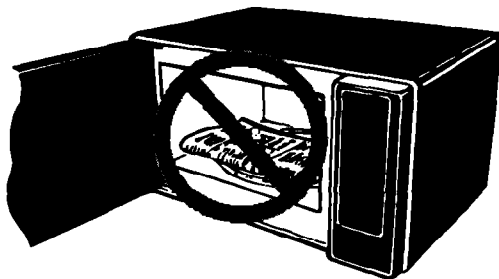

**Do not** use newspaper or other printed paper in the oven. Fire could result.

**Do not** dry flowers, fruit, herbs, wood, paper, gourds or clothes in the oven. Fire could result.

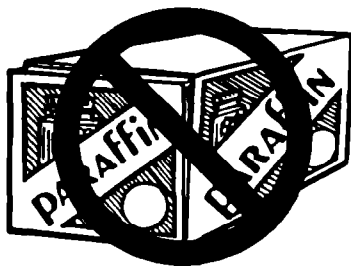

**Do not** try to melt paraffin wax in the oven. Paraffin wax will not melt in a microwave oven because it allows microwaves to pass through it.

## General information

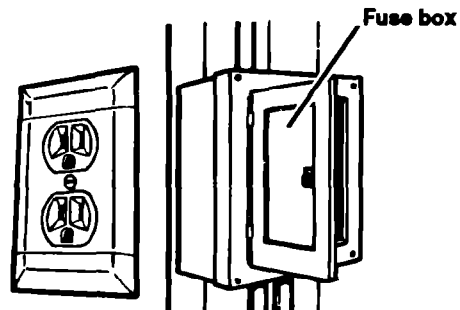

**If your electric power line or outlet voltage** is less than 110 volts, cooking times may be longer. Have a qualified electrician check your electrical system.

# Installation Instructions

Before you begin operating the oven, carefully read the following instructions.

## Installing your microwave oven

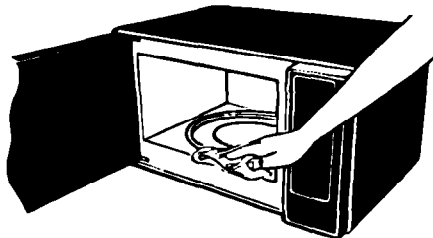

1. **Empty** the microwave oven and **clean** inside it with a soft, damp cloth. **Check** for damage such as misaligned door, damage around the door, or dents inside the oven or on the exterior. If there is any damage, do not operate the unit until it has been checked by an authorized Whirlpool<sup>SM</sup> service technician and any repairs made.

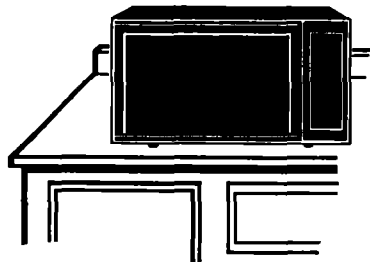

2. **Put** the oven on a cart, counter, table, or shelf that is strong enough to hold the oven and the food and utensils you put in it. (**The control side of the unit is the heavy side. Use care when handling.**) The weight of Model MT2070XA is approximately 35 lbs (15.75 kg). The weight of Model MT3090XA is approximately 50 lbs (22.5 kg). The microwave oven should be at a temperature above 50°F (10°C) for proper operation.

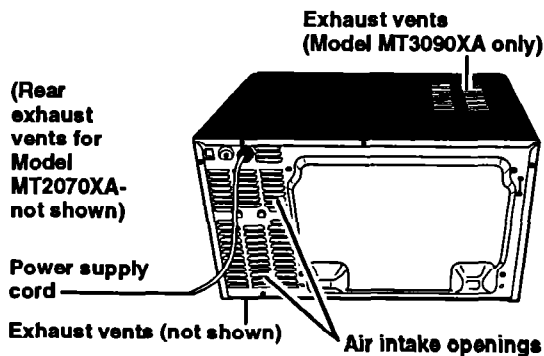

### **⚠ WARNING**

#### **Fire, Electrical Shock, Excessive Exposure To Microwave Energy, Personal Injury and Product Damage Hazard**

- Do not block the rear air intake openings or exhaust vents. Allow a few inches of space at back of oven where intake opening and exhaust vents are located. Blocking the air intake openings and exhaust vents can cause damage to the oven and poor cooking results. Make sure the microwave oven legs are in place to ensure proper airflow.
- Do not install the oven next to or over a heat source (for example, a cooktop or range). Also, do not install oven in any area where excessive heat and steam are generated. This could cause a fire, electrical shock, excessive exposure to microwave energy, other personal injury or damage to the outside of the cabinet.

### **Built-in kits**

You can build your microwave oven into a wall or cabinet by using one of the following kits. Do not build in your microwave oven within 2 feet of any gas or electric range, cooktop or oven.

#### **For Model MT3090XA:**

- 24" for black models (MK3094XAB [4319249])
- 24" for white models (MK3094XAQ [4319248])

#### **For Model MT2070XA:**

- 24" for black models (MK2074XAB [4378054])
- 24" for white models (MK2074XAQ [4378053])

These kits are available from your Whirlpool Dealer. If your dealer does not stock the kit, it can be ordered by writing to:

Whirlpool Corporation  
 Attention: Customer Service Dept.  
 1900 Whirlpool Drive  
 LaPorte, IN 46350

**OR** by returning the customer order card enclosed with your Use and Care Guide.



### 3. Electrical requirements

Observe all governing codes and ordinances. A 120 Volt, 60 Hz, AC only, 15 or 20 amp fused electrical supply is required. (Time-delay fuse is recommended.)

It is recommended that a separate circuit serving only this appliance be provided.

## 4. GROUNDING INSTRUCTIONS

### **⚠ WARNING**

#### Electrical Shock Hazard

Improper use of the grounding plug can result in a risk of electrical shock. **DO NOT, UNDER ANY CIRCUMSTANCES, REMOVE THE POWER SUPPLY CORD GROUNDING PRONG.**

5. For your personal safety, this appliance must be grounded. In the event of an electrical short circuit, grounding reduces the risk of electrical shock by providing an escape wire for the electric current. This appliance is equipped with a polarized 3-prong grounding plug. It must be plugged into a correctly polarized mating 3-prong grounding type wall receptacle, properly installed and grounded in accordance with the National Electrical Code and local codes and ordinances. If a mating wall receptacle is not available or if you are not sure if the wall receptacle is properly grounded and polarized, have it checked by a qualified electrician.

It is the personal responsibility and obligation of the customer to have a properly grounded and correctly polarized 3-prong wall receptacle installed by a qualified electrician.

Consult a qualified electrician if the grounding instructions are not completely understood, or if doubt exists as to whether the appliance is properly grounded.

**It is not recommended to use an extension cord with your microwave oven, but if you find it necessary to do so temporarily (until a properly grounded and polarized 3-prong receptacle is installed), use only a heavy duty UL listed 3-wire grounding type extension cord containing three 16-gauge (minimum) copper wires.** It must not be longer than 10 feet (cords longer than 10 feet may affect the cooking performance of your microwave oven). The plug on the extension cord must fit into a 3-prong grounding type wall receptacle (as shown on this page) and the receptacle end of the extension cord must accept the 3-prong grounding plug of the microwave oven.

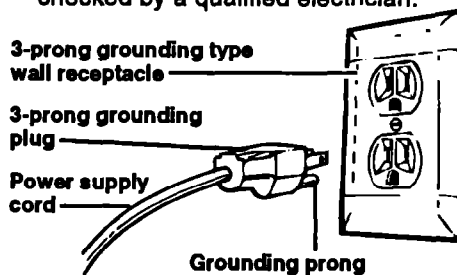

6.  To test the oven, plug it into the proper electrical outlet. Put about one cup (250mL) of cold water in a glass container in the oven. Close the door. Make sure it latches. Follow the directions on page 18 to set the oven to cook for 2 minutes. When the time is up, the water should be heated.

7. **This microwave oven is designed for use in the household only and must not be used for commercial purposes.**

Do not remove the door, control panel or cabinet at any time. The unit is equipped with high voltage and should be serviced by an authorized Whirlpool<sup>SM</sup> service technician.

**- SAVE THESE INSTRUCTIONS -**

# Getting To Know Your Microwave Oven

This section discusses the concepts behind microwave cooking and introduces you to the basics you need to know to operate your microwave oven. Please read this information before use.

## In This Section

	Page	Page	
How your microwave oven works .....	10	Setting the clock .....	15
Microwave oven features .....	12	Using the Minute Timer .....	16
Control panel features .....	13		

## How your microwave oven works

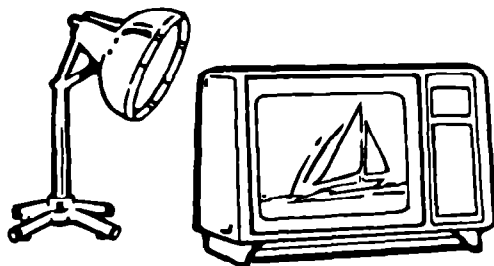

**Microwave ovens are safe.** Microwave energy is not hot. It causes food to make its own heat, and it's this heat that cooks the food.

Microwaves are like TV waves or light waves. You cannot see them, but you can see what they do.

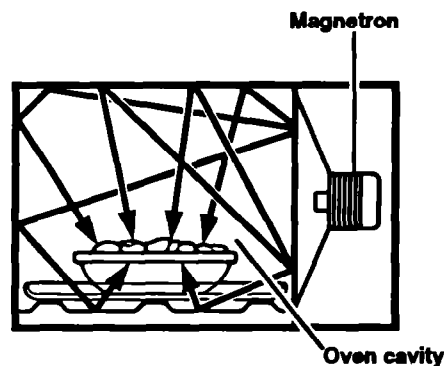

**A magnetron** in the microwave oven produces microwaves. The microwaves move into the oven where they contact food as it turns on the glass turntable.

**Your microwave oven has the Whirlpool patented DUO SYSTEM™ heating system,** which releases microwaves in two locations (one above food and one at bottom of food) for perfectly uniform cooking.

## GETTING TO KNOW YOUR MICROWAVE OVE

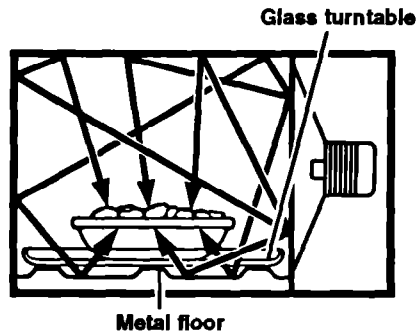

The glass turntable of your microwave oven lets microwaves pass through. Then they bounce off a metal floor, back through the glass turntable, and are absorbed by the food.

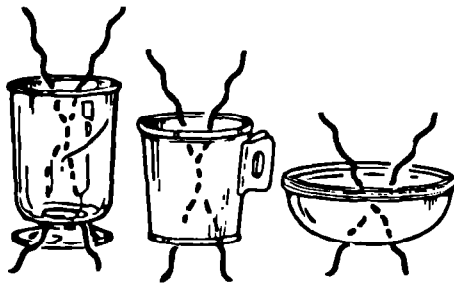

Microwaves pass through most glass, paper and plastics without heating them so food absorbs the energy. Microwaves bounce off metal pans so food does not absorb the energy.

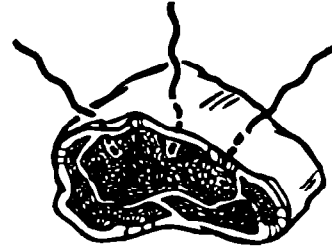

In most microwave ovens, microwaves may not reach the center of a roast. The heat around the outside is what cooks the roast all the way through. This is one of the reasons for letting some foods (roasts, baked potatoes) stand for a while after cooking, or for stirring some foods during the cooking time.

The microwaves disturb water molecules in the food. As the molecules bounce around bumping into each other, heat is made, like rubbing your hands together. This is the heat that does the cooking.

Although your VIP™ microwave oven cooks this way also, the DUO SYSTEM™ heating system allows microwaves to reach the center of the food more easily. This results in faster cooking.

## Microwave oven features

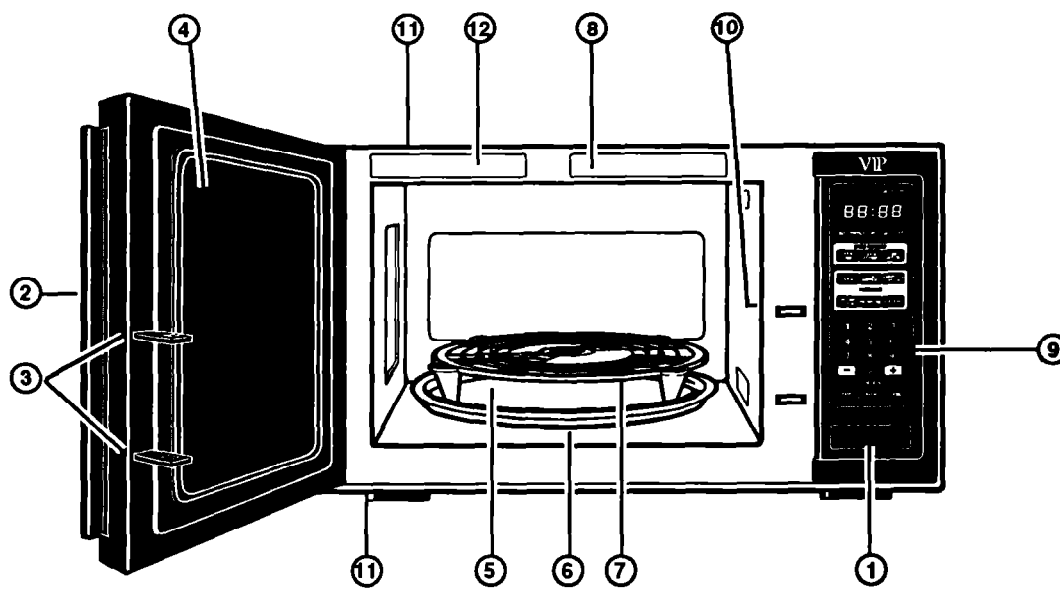

Your microwave oven is designed to make your cooking experience as enjoyable and productive as possible. To help get you up and running quickly, the following is a list of the oven's basic features:

1. **One-Touch Door Open Button** (on Model MT3090XA). Push to open door.
2. **Door Handle** (on Model MT2070XA).
3. **Door Safety Lock System.** The oven will not operate unless the door is securely closed.
4. **Window with Metal Shield.** Shield prevents microwaves from escaping. It is designed as a screen to allow you to view food as it cooks.
5. **Glass Turntable.** This turntable turns food as it cooks for more even cooking. It must be in the oven during operation for best cooking results. See pages 7 and 36 for more details.
6. **Removable Turntable Support** (under turntable).
7. **Bi-Level Cooking Shelf.** Use to cook food on two levels at the same time. Place one plate of food on the turntable and another one above it on the shelf.
8. **Cook Guide Label.**
9. **Control Panel.** Touch pads on this panel to perform all functions. See pages 13 and 14 for more information.
10. **Light.** Automatically turns on when door is opened or when oven is operating.
11. **External Oven Air Vents.** (On top and bottom of Model MT3090XA. Model MT2070XA has vents on bottom and in back.)
12. **Model and Serial Number Plate.**

## Control panel features

Your microwave oven control panel lets you select the desired cooking function quickly and easily. All you have to do is touch the necessary Command Pad. The following is a list of all the Command and Number Pads located on the control panel. For more information, see pages 15-35.

1. **Display.** This display includes indicators to tell you cooking time settings and cooking functions selected.
2. **COOK TIME.** You can touch this pad before entering a cooking time. However, touching this pad is optional. See pages 18 and 20 for more information on entering cooking times.
3. **COOK POWER.** Touch this pad followed by a Number Pad to set the amount of microwave energy released to cook the food. The higher the number, the higher the microwave power or "cooking speed". See page 19 for more information. See the "Microwave cooking chart" on page 38 for specific Cook Powers to use for the foods you are cooking.
4. **ADD MINUTE.** Touch this pad to cook for one minute at 100% Cook Power or to add an extra minute to your cooking cycle. See page 22 for more information.
5. **AUTO COOK.** Touch this pad to cook common microwave-prepared foods without needing to program times and Cook Powers. See page 23 for more information.
6. **AUTO DEFROST.** Touch this pad followed by Number Pads to thaw frozen food by weight. See page 26 for more information.
7. **PERSONAL CHOICE.** Touch this pad to recall one cooking instruction that you previously programmed into memory. See page 30 for more information.
8. **DINNER PLATE.** Touch this pad to reheat a plate of food. The oven will automatically heat for a preset time at a preset Cook Power. See page 32 for more information.

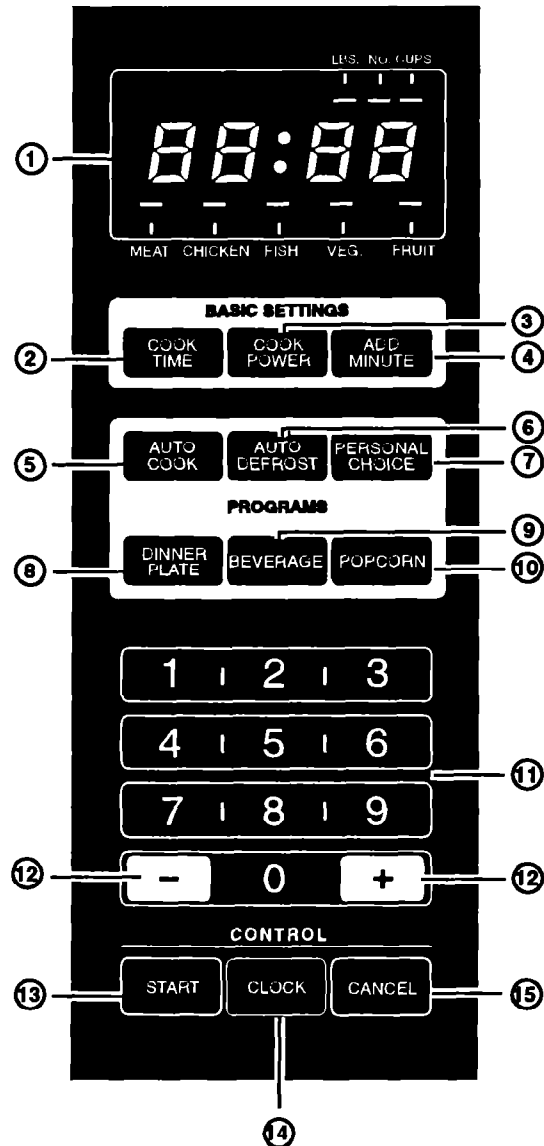

continued on next page

9. **BEVERAGE.** Touch this pad to reheat  $\frac{1}{2}$  cup or 1 cup of a beverage. The oven will automatically heat for a preset time at a preset Cook Power. See page 33 for more information.
10. **POPCORN.** Touch this pad when popping popcorn in your microwave oven. The oven will automatically heat for a preset time at a preset Cook Power. See page 34 for more information.
11. **Number Pads.** Touch Number Pads to enter cooking times, Cook Powers, food classes, quantities or weights.  
**NOTE:** You can change times and Cook Powers during cooking for every function except AUTO DEFROST.
12. **Minus And Plus Pads.** Touch the minus (-) or plus (+) pad to enter amounts or to change cooking times when the microwave oven is in cycle. Each touch of the minus (-) pad decreases the amount by a set number. Each touch of the plus (+) pad increases the amount by a set number. See page 22 for more information.
13. **START.** Touch this pad after setting a function on the microwave oven to start the function. If you open the door after the oven begins to cook, retouch START.
14. **CLOCK.** Touch this pad to enter the correct time of day. See page 15 for more information.
15. **CANCEL.** Touch this pad to erase an incorrect command, to cancel a program during cooking, or to clear the Display.

#### NOTES:

- If you touch two Command Pads for the same cycle (for example, AUTO DEFROST and AUTO COOK), the second command will cancel the first.
- If you attempt to enter unacceptable instructions, nothing will appear in the Display and nothing will sound. Touch CANCEL and re-enter the instructions.

## Audible signals

Audible signals are available to guide you when setting and using your oven:

- **A programming tone will sound** each time you touch a pad.
- **Three tones** signal the end of a cooking cycle.
- **To cancel tones, hold down CANCEL** until you hear a tone (about 3 seconds). Repeat to turn tones back on.

## Interrupting cooking

You can stop the oven during a cycle by opening the door. The oven stops heating and the fan stops, but the light stays on. **To restart cooking, close** the door and

touch



START

**If you do not want to continue cooking:**

- **Close** the door and the light goes off.

OR

- **Touch**



CANCEL

## Setting the clock

When your microwave oven is first plugged in or after a power failure, the Display will only show “:”. If a time of day is not set, then the Display will only show “:” until the cooking time is set.

**NOTE:** You can only set the clock if the oven is not cooking food or timing with the Minute Timer.

### To set time:

#### 1. Choose setting.

TOUCH



You will hear 3 short tones.

YOU SEE



#### 2. Enter time of day.

*Example:*  
TOUCH



*Example:*  
YOU SEE



#### 3. Complete entry.

TOUCH



*Example:*  
YOU SEE



**NOTE:** If you touch CANCEL while setting the clock, the clock will be cleared and the Display will show “:”.

## Using the Minute Timer

Your microwave oven can be used as a kitchen timer. Use the Minute Timer for timing up to 99 minutes, 99 seconds.

### 1. Enter time to be counted down.

*Example:*  
TOUCH



*Example:*  
YOU SEE

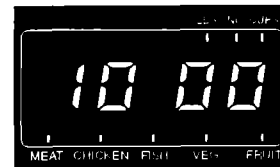

### 2. Enter 0 Cook Power so oven does not go on.

TOUCH



YOU SEE

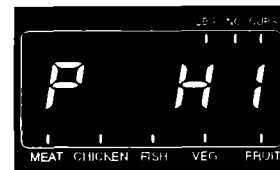

TOUCH



YOU SEE



**After 3 seconds:**

*Example:*  
YOU SEE  
(set time)



### 3. Start count down.

TOUCH



*Example:*  
YOU SEE



The Display will show the time counting down.  
The oven does not start.



# Using Your Microwave Oven

This section gives you instructions for operating each function. Please read these instructions carefully.

<b>In This Section</b>			
	<b>Page</b>		<b>Page</b>
To get the best cooking results .....	17	Using AUTO DEFROST .....	26
Cooking at high cook power .....	18	Auto defrost chart .....	28
Cooking at lower cook powers .....	19	Defrosting tips .....	29
Using ADD MINUTE .....	22	Using PERSONAL CHOICE .....	30
Using the “-” and “+” pads .....	22	Using DINNER PLATE .....	32
Using AUTO COOK .....	23	Using BEVERAGE .....	33
Auto cook chart .....	25	Using POPCORN .....	34

## To get the best cooking results:

- **Although a new rating method\*** rates this oven at 850 watts, you may use a reliable cookbook and recipes developed for microwave ovens previously rated at 700-800 watts.
- **ALWAYS cook** food for the minimum recommended cooking time. Then check for doneness to avoid overcooking the food.
- **Stir thick liquids** being heated about halfway through the heating time for most even doneness with all recipes.
- **If a glass cover is not available, use wax paper, paper towels or microwave-approved plastic wrap. Turn back** a corner to vent steam during cooking.

\* IEC-705 Test Procedure. The IEC-705 Test Procedure is an internationally recognized method of rating microwave wattage output and does not represent an actual change to output power or cooking performance.

## Cooking at high cook power

1. Put food in oven and close door.
2. Set cooking time.

*Example:*  
TOUCH  
(for 1  
minute,  
30 seconds)



*Example:*  
YOU SEE



**NOTE:** A dash (-) will appear in every space where a number has not been entered. The dash(es) will remain until you touch START.

3. Start oven.

TOUCH



*Example:*  
YOU SEE



The oven will automatically cook at high Cook Power. The Display will count down the time to show how much time is left in the cycle.

**At end of cooking time:**

YOU SEE



Three tones will also sound.

4. After cooking, open the door.

OR TOUCH



**NOTE:** If you want to change the cooking time while cooking is in progress, repeat only Step 2 or use ADD MINUTE or the "-" or "+" pads.

## **Cooking at lower cook powers**

For best results, some recipes call for lower Cook Powers. The lower the Cook Power, the slower the cooking. Each Number Pad also stands for a different percentage of Cook Power. Many microwave cookbook recipes tell you by number, percent or name which Cook Power to use.

The following chart gives the percentage of Cook Power each Number Pad stands for, and the Cook Power name usually used. It also tells you when to use each Cook Power:

<b>COOK POWER</b>	<b>WHEN TO USE IT</b>
Automatic 100% of full power HIGH	Quick reheating of foods with high water content, such as beverages. If food contains eggs or cream, choose a lower power.
9=90% of full power	Heating large quantities of liquids, such as water or soup stock.
8=80% of full power	Reheating soups or casseroles.
7=70% of full power MED-HIGH	Cooking and heating vegetables, fish, meat, etc. when you need a lower Cook Power or when food is cooking too fast.
6=60% of full power	Cooking requiring special care, such as for high protein sauces, cheese and egg dishes, and casseroles that need to finish cooking.
5=50% of full power MED	Starting cakes which must be finished on HIGH power or finishing cooking of a large roast.
4=40% of full power	Simmering stews, reheating pastry.
3=30% of full power MED-LOW, DEFROST	Defrosting of foods such as bread, shellfish, and precooked foods.
2=20% of full power	Defrosting and softening butter, cheese and ice cream.
1=10% of full power LOW	Keeping one food serving warm.

# USING YOUR MICROWAVE OVEN

1. Put food in oven and close door.

2. Set cooking time.

*Example:*

TOUCH  
(for 10  
minutes,  
30 seconds)



*Example:*  
YOU SEE



3. Set Cook Power.

TOUCH



YOU SEE

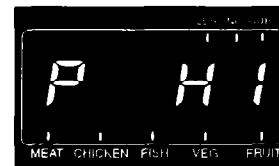

*Example:*  
TOUCH



*Example:*  
YOU SEE



4. Start oven.

TOUCH



*Example:*  
YOU SEE



The Display will count down the time to show how much cooking time is left in the cycle.

At end of cooking time:

YOU SEE



Three tones will also sound.

5. After cooking, open the door.

OR TOUCH



**To check Cook Power after cooking has started:**

TOUCH



*Example:*  
**YOU SEE**  
(for 3  
seconds)



After 3 seconds, the Display will return to counting down the cook time.

**To change Cook Power after cooking has started:**

Set a Cook Power lower than HIGH. (See Step 3 on page 20.)

OR

• Touch



*twice* to change from a lower Cook Power to HIGH.

**NOTES:**

- When setting a lower Cook Power, you must touch the desired Number Pad within 3 seconds after touching COOK POWER. There is, however, no time limit when cooking is interrupted and the door is open.
- You cannot change the Cook Power when oven is operating during AUTO DEFROST.

## Using ADD MINUTE

ADD MINUTE lets you cook for one minute at 100% Cook Power or add an extra minute to your cooking cycle. You can also use it to extend cooking time in multiples of one minute.

### NOTES:

- To extend cooking time in multiples of one minute, touch ADD MINUTE repeatedly during cooking.
- You can enter ADD MINUTE only after closing the door.
- You cannot use ADD MINUTE with AUTO DEFROST.

1. Make sure food is in oven.

2. Choose setting.

TOUCH



*Example  
For Cooking  
For One Minute:  
YOU SEE*



When cooking time ends:

YOU SEE

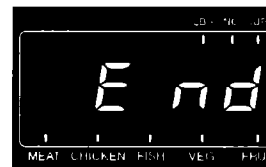

Three tones will also sound.

## Using the “-” and “+” pads

You can use the minus (-) and plus (+) pads instead of the Number Pads to enter amounts or to change cooking times when the microwave oven is in cycle. Each touch of the minus or plus pad decreases/increases amounts:

- in 30-second increments from 0 to 16:00
- in 1-minute increments from 16:00 to 25:00
- in 5-minute increments from 25:00 to 99:00

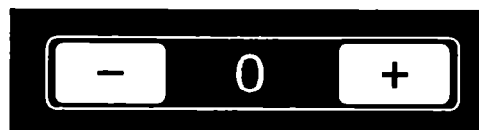

## Using AUTO COOK

Cooking with AUTO COOK lets you cook common microwave-prepared foods without needing to program times and Cook Powers. AUTO COOK has preset times and Cook Powers for six major food categories: Baked Potatoes; Rolls, Muffins; Fresh Vegetables; Frozen Vegetables; Canned Vegetables; Casseroles (see chart on page 25). All you do is touch the Number Pad assigned to the desired category and enter the number of items being heated. Your microwave oven does the rest.

**1. Put food in oven and close door.**

**2. Choose setting.**

TOUCH



YOU SEE



**3. Choose food class.**

*Example:*  
TOUCH



*Example:*  
YOU SEE



To choose the desired food class, see the "Auto cook chart" on page 25.

Depending on the food class chosen, the indicator under either "NO." or "CUPS" flashes on the Display.

**4. Enter number of items (or cups) to be heated.**

*Example:*  
TOUCH



*Example:*  
YOU SEE



# USING YOUR MICROWAVE OVEN

## 5. Start oven.

TOUCH



**Example:  
YOU SEE**



The Display will count down the time to show how much cooking time is left in the cycle.

**At end of cooking time:**

**YOU SEE**



Three tones will also sound.

## 6. After cooking, open the door.

OR

TOUCH





## Auto cook chart

CLASS	FOOD	AMOUNT	PROCEDURE
1	<b>Baked Potatoes</b>	1-6 med size	Prick; place on paper towel directly on turntable. After cooking, remove from oven and let stand wrapped in foil 5 minutes.  <b>NOTE:</b> For large (8-10 ounce) potatoes, enter a quantity greater than the actual number of potatoes to be cooked. (Example: for one large potato, enter "4".) For small (4 ounce) potatoes, enter a quantity less than the actual number of potatoes to be cooked. (Example: for three small potatoes, enter "1" or "2".) Use ADD MINUTE or the "-" or "+" pads to change cooking time. See page 22 for more information.
2	<b>Rolls, Muffins</b>	1-6 pieces	Arrange on a double layer of paper towels; cover with another towel.
3	<b>Fresh Vegetables</b>	1-4 cups	Place in a microwave-safe container. For beans, carrots, corn, and peas, add 1 tablespoon water per cup. For broccoli, brussels sprouts, cabbage and cauliflower, cook immediately after washing with no additional water. If you like tender-crisp vegetables, set the Auto Cook quantity for half the amount of vegetables you are actually cooking. For example, when cooking 2 cups of vegetables, set AUTO COOK for 1 cup. Cover with lid or plastic wrap. After cooking, remove from oven, stir, cover and let stand 3 to 5 minutes before serving.
4	<b>Frozen Vegetables</b>	1-4 cups	Place in a microwave-safe container. Cover with lid or plastic wrap. After cooking remove from oven, stir, cover and let stand 3 minutes before serving.
5	<b>Canned Vegetables</b>	1-4 cups	Place in a microwave-safe container. Cover with lid or plastic wrap. After cooking remove from oven, stir, cover and let stand 3 minutes before serving.
6	<b>Casseroles</b>	1-4 cups	To reheat, flatten on plate or place in bowl. Cover with vented plastic wrap. Stir before serving, if possible.

**NOTE:** When cooking a 10 oz package of frozen vegetables (this equals about 1½ cups), touch "1" for 1 cup of "tender crisp" vegetables (you cannot enter ½ cup amounts) or touch "2" for two cups of vegetables more fully cooked.

## Using AUTO DEFROST

Your microwave oven automatically defrosts a variety of common foods at preset Cook Powers for preset times. The 3-stage Auto Defrost Cycle is programmed for Meat, Poultry, Fish, Vegetables, and Fruit. All you do is touch the Number Pad assigned to the desired category and enter the weight of the items being heated. Your microwave oven does the rest.

1. Put frozen food in oven and close door.

2. Choose setting.

TOUCH



YOU SEE



3. Choose food class.

Example:  
TOUCH



Example:  
YOU SEE



To choose the desired food class, see the "Auto defrost chart" on page 28.

4. Enter food's weight (in pounds, tenths and hundredths of a pound).

Example:  
TOUCH



Example:  
YOU SEE



See the "Weight conversion chart" on page 29 for help in converting food weight to decimals.

See the "Auto defrost chart" on page 28 for weight ranges available for each food category.

## 5. Start oven.

TOUCH



*Example:*  
YOU SEE



The Display will count down the time to show how much defrosting time is left in the cycle.

**NOTE:** Standing time is included in AUTO DEFROST times. This may make defrost times seem longer than in other microwave ovens. (See page 29 for more information.)

**At end of defrosting time:**

YOU SEE



Three tones will also sound.

## 6. After defrosting, open the door.

OR

TOUCH



## Auto defrost chart

CLASS	FOOD	MINIMUM WEIGHT	MAXIMUM WEIGHT
1	<b>Meat</b> <ul style="list-style-type: none"> <li>• Pork Chops</li> <li>• Steaks</li> <li>• Roasts</li> <li>• Ground Meat</li> </ul>	.10 lb (2 oz)	6.60 lbs (6 lbs, 10 oz)
2	<b>Poultry</b> <ul style="list-style-type: none"> <li>• Chicken, Whole or In Pieces</li> <li>• Turkey</li> <li>• Cornish Hens</li> <li>• Whole Duckling</li> </ul>	.10 lb (2 oz)	6.60 lbs (6 lbs, 10 oz)
3	<b>Fish</b> <ul style="list-style-type: none"> <li>• Steaks</li> <li>• Fillets</li> <li>• Whole Fish</li> <li>• Lobster Tails</li> <li>• Shrimp, Scallops</li> </ul>	.10 lb (2 oz)	4.40 lbs (4 lbs, 6 oz)
4	<b>Vegetables</b> <ul style="list-style-type: none"> <li>• Broccoli</li> <li>• Cauliflower</li> <li>• Mixed Vegetables</li> <li>• Other Frozen Vegetables</li> </ul>	.10 lb (2 oz)	4.40 lbs (4 lbs, 6 oz)
5	<b>Fruit</b> <ul style="list-style-type: none"> <li>• Strawberries</li> <li>• Blueberries</li> <li>• Raspberries</li> <li>• Mixed Fruit</li> </ul>	.10 lb (2 oz)	4.40 lbs (4 lbs, 6 oz)

**NOTES:**

- If you enter an amount not shown in the chart above, 3 tones will sound. AUTO DEFROST will only operate within the weight ranges shown in the chart. **Round** weights of food items to the nearest tenth of a pound.
- To defrost items not listed in AUTO DEFROST, **use** 30% Cook Power.

## Weight conversion chart

You are probably used to food weights as being in pounds and ounces that are fractions of a pound (for example 4 ounces equals  $\frac{1}{4}$  pound). However, in order to enter food weight in AUTO DEFROST, you must specify pounds and tenths of a pound. If the weight on the food package is in fractions of a pound, you can use the following chart to convert the weight to decimals.

NUMBER AFTER DECIMAL	EQUIVALENT OUNCE WEIGHT
.10	1.6
.20	3.2
.25     One-Quarter Pound	4.0
.30	4.8
.40	6.4
.50     One-Half Pound	8.0
.60	9.6
.70	11.2
.75     Three-Quarters Pound	12.0
.80	12.8
.90	14.4
1.00     One Pound	16.0

## Defrosting tips

- **When using** AUTO DEFROST, the weight to be entered is the net weight in pounds and tenths of pounds (the weight of the food minus the container).
- **Only use** AUTO DEFROST for raw food. AUTO DEFROST gives best results when food to be thawed is a minimum of 0°F (taken directly from a "true" freezer). If food has been stored in a refrigerator-freezer that does not maintain a temperature of 0°F or below, always program a lower food weight (for a shorter defrosting time) to prevent cooking the food.
- **If the food is stored outside** the freezer for up to 20 minutes, enter a lower food weight.
- **If the food is stored outside** the freezer for more than 20 minutes, and for defrosting ready-made food, defrost by time and power and let stand after defrosting.
- **The shape of the package** alters the defrosting time. Shallow rectangular packets defrost more quickly than a deep block.
- **Separate pieces** as they begin to defrost. Separated pieces defrost more easily.
- **You can use small pieces** of aluminum foil to shield foods like chicken wings, leg tips, and fish tails, but the foil must not touch the side of the oven. Foil can damage the oven lining.
- **Shield areas of food** with small pieces of foil if they start to become warm.
- **For better results, a preset standing time** is included in the defrosting time. This may make the defrosting time seem longer than expected. (For more information on standing time, see "Cooking tips" on page 39.)

## Using PERSONAL CHOICE

PERSONAL CHOICE lets you recall one cooking instruction previously placed in memory and begin cooking quickly. For example, if you heat a roll every morning, program the cooking steps into PERSONAL CHOICE. You can heat your roll each morning by touching PERSONAL CHOICE.

PERSONAL CHOICE also lets you program a recipe for another person to cook at a later time.

**NOTE:** You can store a cooking time and Cook Power for a standard cooking cycle, a food class and weight for AUTO DEFROST, or a food class and quantity for AUTO COOK.

### To program PERSONAL CHOICE:

#### 1. Choose setting.

TOUCH  
*twice*



**Example:**  
**YOU SEE**  
(the last  
information  
preprogrammed  
with PERSONAL  
CHOICE)

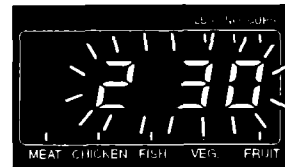

Three tones will sound.

#### 2. Choose the setting to be programmed.

**Example:**  
TOUCH



**YOU SEE**

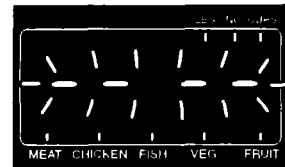

**NOTE:** When programming a cooking time for PERSONAL CHOICE, you must first touch COOK TIME.

#### 3. Set cooking time (or food class).

**Example:**  
TOUCH



**Example:**  
**YOU SEE**



**4. Set Cook Power (or quantity or weight).**

*Example:*  
TOUCH



*Example:*  
YOU SEE



*Example:*  
TOUCH



*Example:*  
YOU SEE



**5. Enter program.**

TOUCH



*Example:*  
YOU SEE



**NOTE:** The Display shows your chosen setting. To clear the Display, touch CANCEL.

**To use PERSONAL CHOICE:**

**1. Choose setting.**

TOUCH



*Example:*  
YOU SEE  
(your preset  
time or  
weight)



After a short delay, the oven will start.

**NOTES:**

- You cannot use PERSONAL CHOICE while another function is running.
- The oven will start automatically two seconds after you release the command pad.

**At end of cooking time:**

**YOU SEE**



Three tones will also sound.

## Using DINNER PLATE

DINNER PLATE lets you reheat a plate of food by touching just one command pad.

### 1. Place plate of food in oven and close door.

**NOTE:** Cover food with vented plastic wrap.

### 2. Choose setting.

TOUCH



#### NOTES:

- You cannot use DINNER PLATE while another function is running.
- The oven will start automatically as soon as you release the command pad.

**YOU SEE**  
(preset  
reheating  
time)



The Display will count down the time to show how much reheating time is left in the cycle.

**At end of reheating time:**

**YOU SEE**



Three tones will also sound.



## Using BEVERAGE

BEVERAGE lets you reheat  $\frac{1}{2}$  cup or 1 cup of beverage by touching just one command pad.

1. Place cup of beverage in oven and close door.

2. Choose setting.

TOUCH  
*once* for  
 $\frac{1}{2}$  cup

BEVERAGE

YOU SEE  
(preset  
reheating  
time)



TOUCH  
*twice* for  
1 cup

BEVERAGE

YOU SEE  
(preset  
reheating  
time)



After a short delay, the oven will start.

### NOTES:

- You cannot use BEVERAGE while another function is running.
- The oven will start automatically two seconds after you release the command pad.

The Display will count down the time to show how much reheating time is left in the cycle.

At end of reheating time:

YOU SEE



Three tones will also sound.

## Using POPCORN

POPCORN lets you pop popcorn by touching just one pad.

1. Place bag in center of turntable and close door.

2. Choose setting.

Model MT3090XA:

TOUCH  
*once* for most  
regular-size  
(3.5 oz) bags  
of microwave  
popcorn

POPCORN

YOU SEE



OR TOUCH  
*twice* for big  
(7.0 oz) bags

POPCORN

YOU SEE



POPCORN

OR TOUCH  
*3 times* for  
most single  
serving  
(1.75 oz) bags

POPCORN

YOU SEE



POPCORN

POPCORN

The Display will count down the time to show how much cooking time is left in the cycle.

At end of cooking time:

YOU SEE



**NOTE:** The oven will start automatically two seconds after you release the command pad.

Three tones will also sound.

## Model MT2070XA:

TOUCH  
*once* for most  
regular-size  
(3.5 oz) bags  
of microwave  
popcorn



YOU SEE



OR TOUCH  
*twice* for  
most single  
serving  
(1.75 oz) bags



YOU SEE



**NOTE:** The oven will start automatically two seconds after you release the command pad.

The Display will count down the time to show how much cooking time is left in the cycle.

**At end of cooking time:**

YOU SEE



Three tones will also sound.

### 3. After cooking, open the door.

OR TOUCH



#### NOTES:

- Cooking performance may vary with brand. Try several brands to decide which gives best popping results. For best results, use fresh bags of popcorn.
- POPCORN is designed for commercially bagged microwave popcorn. If you are using a microwave popcorn popper, follow instructions with the popper for cooking time.
- Use only 1 package at a time.
- Use only popcorn packages designed for microwave ovens or a microwave-approved popcorn popper.

## ⚠ WARNING

### Fire and Burn Hazard

- Do not try to repop unpopped kernels and do not reuse popcorn bags. Fire may result.
- If you remove the turntable right after popping popcorn, use oven mitts. It will be very hot and could burn you.

# Caring For Your Microwave Oven

To make sure your microwave oven looks good and works well for a long time, you should maintain it properly. For proper care, please follow these instructions carefully.

## Cleaning the microwave oven

### NOTES:

- Your VIP™ microwave oven has a stainless steel interior. Unlike the painted steel interiors found in most other microwave ovens, the surface will not chip, rust or corrode.
- Do not use metal scouring pads on inside of oven cavity. They will scratch the surface.

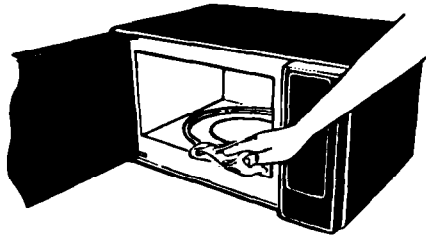

Wipe often with warm, sudsy water and a sponge or paper towel. You can remove the glass turntable to clean the oven cavity floor; however, this oven is designed to operate with the turntable in place. **Do not** operate the microwave oven when turntable is removed for cleaning. See page 7 for further information about the turntable.

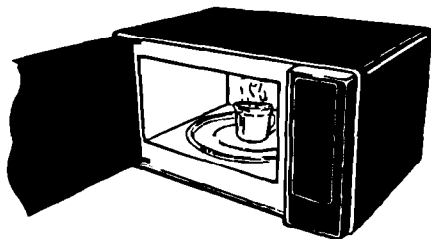

For stubborn soil, **boil** a cup of water in the oven for 2 or 3 minutes. Steam will soften the soil. To get rid of odors inside the oven, **boil** a cup of water with lemon juice.

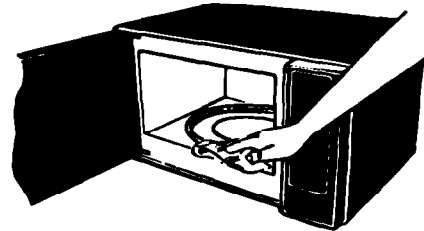

Be sure to keep the areas clean where the door and oven frame touch when closed. Use only mild, nonabrasive soaps or detergents applied with a sponge or paper towel when cleaning surfaces. **Rinse** well.

### ⚠ CAUTION

#### Product Damage Hazard

Abrasive cleansers, steel-wool pads, gritty wash cloths, etc., can damage the control panel, and the interior and exterior oven surfaces. Use a sponge with a mild detergent or a paper towel with spray glass cleaner. Apply spray glass cleaner to paper towel; do not spray directly on oven.

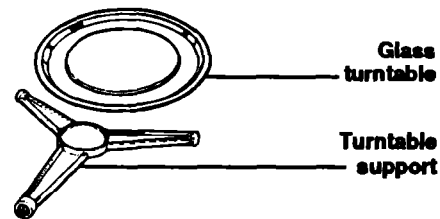

To clean turntable and turntable support, wash in mild, sudsy water; for heavily soiled areas use a mild cleanser and scouring sponge. The turntable and turntable support are dishwasher-safe.

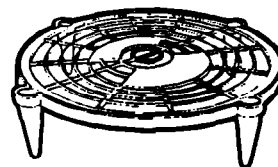

To clean the BI-Level Cooking Shelf, wash in mild, sudsy water; for heavily soiled areas use a mild cleanser and scouring sponge. Shelf is dishwasher-safe.

# Cooking Guide

## Reheating chart

Times are approximate and may need to be adjusted to individual taste.

ITEM	STARTING TEMP	TIME/POWER	PROCEDURE
Meat (Chicken pieces, chops, hamburgers, meat loaf slices) 1 serving 2 servings	Refrigerated Refrigerated	1-2 min at 70% 2½-4½ min at 70%	Cover loosely.
Meat Slices (Beef, ham, pork, turkey) 1 or more servings	Room temp Refrigerated	45 sec-1 min per serving at 50% 1-3 min per serving at 50%	Cover with gravy or wax paper. Check after 30 sec per serving.
Stirrable Casseroles and Main Dishes 1 serving 2 servings 4-6 servings	Refrigerated Refrigerated Refrigerated	2-4 min at 100% 4-6 min at 100% 6-8 min at 100%	Cover. Stir after half the time.
Nonstirrable Casseroles and Main Dishes 1 serving 2 servings 4-6 servings	Refrigerated Refrigerated Refrigerated	5-8 min at 50% 9-12 min at 50% 13-16 min at 50%	Cover with wax paper.
Soup, Cream 1 cup 1 can (10¾ oz)	Refrigerated Room temp	3-4½ min at 50% 5-7 min at 50%	Cover. Stir after half the time.
Soup, Clear 1 cup 1 can (10¾ oz)	Refrigerated Room temp	2½-3½ min at 100% 4-5½ min at 100%	Cover. Stir after half the time.
Pizza 1 slice 1 slice 2 slices 2 slices	Room temp Refrigerated Room temp Refrigerated	15-25 sec at 100% 30-40 sec at 100% 30-40 sec at 100% 45-55 sec at 100%	Place on paper towel.
Vegetables 1 serving 2 servings	Refrigerated Refrigerated	¾-1½ min at 100% 1½-2½ min at 100%	Cover. Stir after half the time.
Baked Potato 1 2	Refrigerated Refrigerated	1-2 min at 50% 2-3 min at 50%	Cut potato lengthwise and then several times crosswise. Cover with wax paper.
Breads (Dinner or breakfast roll) 1 roll 2 rolls 4 rolls	Room temp Room temp Room temp	8-12 sec at 50% 11-15 sec at 100% 18-22 sec at 100%	Wrap single roll, bagel or muffin in paper towel. To reheat several, line plate with paper towel. Cover with another paper towel.
Pie Whole 1 slice	Refrigerated Refrigerated	5-7 min at 70% 30 sec at 100%	

## Microwave cooking chart

Times are approximate and may need to be adjusted to individual taste.

<b>MEATS, POULTRY, FISH, SEAFOOD</b> Allow standing time after cooking.			<b>VEGETABLES (continued)</b> Cook on 100% Cook Power.	
<b>FOOD</b>	<b>COOK POWER</b>	<b>TIME</b>	<b>FOOD</b>	<b>TIME</b>
<b>Bacon</b>	100%	45 sec to 1 min 15 sec per slice	<b>Carrots (1 lb)</b>	8-12 min
<b>Ground Beef For Casseroles (1 lb)</b>	100%	4-6 min	<b>Cauliflower (medium head)</b>	6-9 min
<b>Hamburger Patties (2)</b>	100%	1st side 2 min 2nd side 1½ to 2½ min	<b>Corn On The Cob (2)</b>	4-9 min
<b>Hamburger Patties (4)</b>	100%	1st side 2½ min 2nd side 2-3 min	<b>(4)</b>	6-16 min
<b>Meat Loaf (1½ lbs)</b>	100%	13-19 min	<b>Potatoes, Baked (4 medium)</b>	13-19 min
<b>Chicken Pieces</b>	100%	6-9 min/lb Internal temperature should be 185°F after standing.	<b>Squash, Summer (1 lb)</b>	3-8 min
<b>Turkey Breast</b>	100% then 70%	5 min 8-12 min/lb Internal temperature should be 185°F after standing.	<b>OTHER</b>	
<b>Fish Fillets (1 lb)</b>	100%	5-6 min	<b>FOOD</b>	<b>COOK POWER</b>
<b>Scallops And Shrimp (1 lb)</b>	100%	3½-5½ min	<b>FOOD</b>	<b>TIME</b>
<b>VEGETABLES</b> Cook on 100% Cook Power.			<b>Applesauce (4 servings)</b>	100% 7-10 min
<b>FOOD</b>		<b>TIME</b>	<b>Baked Apples (4)</b>	100% 4-6 min
<b>Beans, Green Or Yellow (1 lb)</b>		6-12 min	<b>Chocolate (melt 1 square)</b>	50% 1-2 min
<b>Broccoli (1 lb)</b>		6-10 min	<b>Eggs, Scrambled (2)</b>	100% 1 min 15 sec to 1 min 45 sec
			<b>(4)</b>	2-3 min
			<b>Hot Cereals (1 serving)</b>	100% 1½-5 min
			<b>(4 servings)</b>	4½-7 min
			<b>Nachos (large plate)</b>	50% 1½-2½ min
			<b>Water For Beverage (1 cup)</b>	100% 2½-4 min
			<b>(2 cups)</b>	4½-6 min

## Cooking tips

### Amount of food

- **The more food** you want to prepare, the longer it takes. A rule of thumb is that a double amount of food requires almost double the time. If one potato takes four minutes to cook, you need about seven minutes to cook two potatoes.
- **If you want to cook two meals or containers of food** at the same time, you can do so with the Bi-Level Cooking Shelf. For example, you can cook two frozen dinners or reheat two plates of food by placing one on the shelf and one under the shelf. The DUO SYSTEM™ heating system will heat both servings equally.

### Starting temperature of food

- **The lower the temperature** of the food being put into the microwave oven, the longer it takes to cook. Food at room temperature will be reheated more quickly than food at refrigerator temperature.

### Composition of food

- **Food with a lot of fat and sugar** will be heated faster than food containing a lot of water. Fat and sugar will also reach a higher temperature than water in the cooking process.
- **The more dense the food**, the longer it takes to heat. "Very dense" food like meat takes longer to reheat than lighter, more porous food like sponge cakes.

### Size and shape

- **Smaller pieces of food** will cook faster than larger pieces and same-shaped pieces of food cook more evenly than irregularly shaped foods.
- **With unevenly shaped foods**, the thinner parts will cook faster than the thicker areas. **Place** the thinner parts of chicken wings and legs in the center of the dish.

### Stirring, turning foods

- **Stirring and turning foods** distributes heat quickly to the center of the dish and avoids overcooking at the outer edges of the food.

### Covering food

#### Cover food to:

- **Reduce** splattering
- **Shorten** cooking times
- **Retain** food moisture

All coverings that allow microwaves to pass through are suitable.

### Releasing pressure in foods

- **Several foods** (for example, baked potatoes, sausages, egg yolks, and some fruits) are tightly covered by a skin or membrane. This can cause the food to burst from steam building up in them during cooking. To relieve the pressure and to prevent bursting, **prick** these foods with a fork, cocktail pick or toothpick.

### Using standing time

- **Always allow food to stand** for a while after cooking. Standing time after defrosting, cooking, or reheating always improves the result since the temperature will then be evenly distributed throughout the food.
- **When cooking in a microwave oven**, food continues to cook even when the microwave energy is turned off. Food is no longer cooked by microwaves, but it is still being cooked by the high heat left over from the microwave oven.
- **The length of the standing time** depends on the volume and density of the food. Sometimes it can be as short as the time it takes you to remove the food from the oven and take it to the serving table. However, with larger, denser food, the standing time may be as long as 10 minutes. During standing time, the internal food temperature will rise as much as 46°F as the food finishes cooking.

## Arranging food

For best results, distribute food evenly on the plate. You can do this in several ways:

- **If you are cooking several items of the same food**, such as baked potatoes, **place** them in a ring pattern for uniform cooking.
- **When cooking foods of uneven shapes or thickness**, **place** the smaller or thinner area of the food towards the center of the dish where it will be heated last.
- **Arrange uneven foods**, such as fish, in the oven with the tails to the center.
- **If you are saving a meal in the refrigerator** or “plating” a meal for reheating, **arrange** the thicker, denser foods to the outside of the plate and the thinner or less dense foods in the middle.
- **Place thin slices** of meat on top of each other or interlace them.
- **Place thicker slices**, such as meat loaf and sausages close to each other.
- **Reheat gravy or sauce** in a separate container.
- **Choose a tall, narrow container** rather than a low and wide container. When reheating gravy, sauce or soup, do not fill the container more than  $\frac{3}{4}$ .
- **When you cook or reheat whole fish**, **score** the skin – this prevents cracking.
- **Shield the tail and head of whole fish** with small pieces of foil to prevent overcooking and ensure the foil does not touch the sides of the oven.
- **Do not** let food or container touch the top or sides of the oven. This will prevent possible arcing.

## Using aluminum foil

Metal containers usually should not be used in a microwave oven. There are, however, some exceptions. If you have purchased food which is prepackaged in an aluminum foil container, then refer to the instructions on the package. It is possible to use disposable containers, but it generally takes longer and the final result will not be as good as if food were placed in plastic or paper containers. If you use aluminum containers without package instructions, follow these guidelines:

- **Place** container in a glass bowl and add some water so that it covers the bottom of the container, not more than  $\frac{1}{4}$  inch high. This ensures even heating of the container bottom.
- **Always remove** the lid to avoid damage to the oven.
- **Use only** undamaged containers.
- **Do not use** containers taller than  $\frac{3}{4}$ ".
- **Container must be** half filled.
- **To avoid sparking**, there must be a minimum  $\frac{1}{4}$ " between the aluminum container and the walls of the oven and also between two aluminum containers.
- **Always place** container on turntable.
- **Thickness of the food layer** must be greater than thickness of the aluminum.
- **Reheating food** in aluminum foil containers usually takes up to double the time compared to reheating in plastic, glass, china, or paper containers. The time when food is ready will vary a great deal.
- **Let food stand** for 2-3 minutes after heating so that heat is spread evenly throughout container.

## Cooking you should not do in your microwave oven

- **Do not** do canning of foods in the oven. Closed glass jars may explode, resulting in damage to the oven or possible personal injury.
- **Do not** use the oven to sterilize objects (baby bottles, etc.). It is difficult to maintain the high temperature required for safe sterilization.



# Questions And Answers

QUESTIONS	ANSWERS
Can I operate my microwave oven without the turntable or turn the turntable over to accommodate a large dish?	No. If you remove or turn over the turntable, you will get poor cooking results. Dishes used in your oven must fit on the turntable.
Can I use a rack in my microwave oven so that I may reheat or cook on two levels at a time?	Yes. Use the Bi-Level Cooking Shelf provided with your oven.
Can I use either metal or aluminum pans in my microwave oven?	Useable metal includes aluminum foil for shielding (use small, flat pieces), small skewers and shallow foil trays (if tray is 3/4 inch deep and filled with food to absorb microwave energy). Never allow metal to touch walls or door.
Is it normal for the turntable to turn in either direction?	Yes. The turntable rotates clockwise or counterclockwise, depending on the rotation of the motor when the cooking cycle begins.
Sometimes the door of my microwave oven appears wavy. Is this normal?	This appearance is normal and does not affect the operation of your oven.
What are the humming noises that I hear when my microwave oven is operating?	You hear the sound of the magnetron tube cycling on and off when cooking at less than 100% power.
Why does the dish become hot when I microwave food in it? I thought that this should not happen.	As the food becomes hot it will conduct the heat to the dish. Be prepared to use hot pads to remove food after cooking.
What does "standing time" mean?	"Standing time" means that food should be taken out of the oven and covered for additional time after cooking. This process allows the cooking to finish, saves energy and frees the oven for another purpose.
Can I pop popcorn in my microwave oven? How do I get the best results?	Yes. Pop packaged microwave popcorn following manufacturer's guidelines or use the Popcorn pad. Do not use regular paper bags. Use the "listening test" by stopping the oven as soon as the popping slows to a "pop" every one or two seconds. Do not try to repop unpopped kernels. Use only special microwave poppers, being sure to follow manufacturer's directions. Do not pop popcorn in glass utensils.

# If You Need Assistance Or Service

This section is designed to help you save the cost of a service call. Part 1 of this section outlines possible problems, their causes, and actions you can take to solve each problem. Parts 2 and 3 tell you what to do if you still need assistance or service. When calling our Consumer Assistance Center for help or calling for service, please provide a detailed description of the problem, your appliance's complete model and serial numbers and the purchase date. (See page 2.) This information will help us respond properly to your request.

## 1. Before calling for assistance ...

Performance problems often result from little things you can find and fix without tools of any kind. Please check the chart below for problems you can fix. It could save you the cost of a service call.

<b>PROBLEM</b>	<b>POSSIBLE CAUSE</b>	<b>SOLUTION</b>
<b>Nothing will operate</b>	<p>The power supply cord is not plugged into a live circuit with the proper voltage.</p> <p>A household fuse has blown or a circuit breaker has tripped.</p> <p>The electric company has experienced a power failure.</p>	<p>Plug power supply cord into a live circuit with the proper voltage. (See pages 7 and 9.)</p> <p>Replace household fuse or reset circuit breaker.</p> <p>Check electric company for a power failure.</p>
<b>The microwave oven will not run</b>	<p>You are using the oven as a timer.</p> <p>The door is not firmly closed and latched.</p> <p>You did not touch START.</p> <p>You did not follow directions exactly.</p> <p>An operation that was programmed earlier is still running.</p>	<p>Touch CANCEL to cancel the Minute Timer.</p> <p>Firmly close and latch door.</p> <p>Touch START.</p> <p>Check instructions for the function you are operating.</p> <p>Touch CANCEL to cancel previous programming.</p>
<b>Microwave cooking times seem too long</b>	<p>The electric supply to your home or wall outlets is low or lower than normal.</p> <p>The Cook Power is not at the recommended setting.</p> <p>There is not enough cooking time for the amount of food being cooked.</p>	<p>Your electric company can tell you if the line voltage is low. Your electrician or service technician can tell you if the outlet voltage is low.</p> <p>Check "Microwave cooking chart" on page 38.</p> <p>Allow for more time when cooking more food at one time.</p>
<b>The Display shows a time counting down but the oven is not cooking</b>	<p>The oven door is not closed completely.</p> <p>You have set the controls as a kitchen timer.</p>	<p>Completely close oven door.</p> <p>Touch CANCEL to cancel the Minute Timer.</p>

<b>PROBLEM</b>	<b>POSSIBLE CAUSE</b>	<b>SOLUTION</b>
<b>You do not hear the Programming Tone</b>	The command is not correct.	Re-enter command.
<b>The fan seems to be running slower than usual</b>	The oven has been stored in a cold area.	The fan will run slower until the oven warms up to normal room temperature.

**2. If you need assistance ...**

Call Whirlpool Consumer Assistance Center telephone number. Dial free from anywhere in the U.S.:

**1-800-253-1301**

and talk with one of our trained consultants. The consultant can instruct you in how to obtain satisfactory operation from your appliance or, if service is necessary, recommend a qualified service company in your area.

If you prefer, write to:

Mr. William Clark  
 Consumer Assistance Representative  
 Whirlpool Corporation  
 2000 M-63  
 Benton Harbor, MI 49022

Please include a daytime phone number in your correspondence.

**3. If you need service ...**



Whirlpool has a nationwide network of authorized Whirlpool<sup>SM</sup> service companies. Whirlpool service technicians are

trained to fulfill the product warranty and provide after-warranty service, anywhere in the United States. To locate the authorized Whirlpool service company in your area, call our Consumer Assistance Center telephone number (see Step 2) or look in your telephone directory Yellow Pages under:

• **APPLIANCE-HOUSEHOLD-MAJOR, SERVICE & REPAIR**  
 - See: Whirlpool Appliances or Authorized Whirlpool Service (Example: XYZ Service Co.)

• **WASHING MACHINES & DRYERS, SERVICE & REPAIR**  
 - See: Whirlpool Appliances or Authorized Whirlpool Service (Example: XYZ Service Co.)

**4. If you are not satisfied with how the problem was solved ...**

- Contact the Major Appliance Consumer Action Panel (MACAP). MACAP is a group of independent consumer experts that voices consumer views at the highest levels of the major appliance industry.
- Contact MACAP only when the dealer, authorized servicer and Whirlpool have failed to resolve your problem.  
 Major Appliance Consumer Action Panel  
 20 North Wacker Drive  
 Chicago, IL 60606
- MACAP will in turn inform us of your action.

# WHIRLPOOL®

## Microwave Oven Warranty

LENGTH OF WARRANTY	WHIRLPOOL WILL PAY FOR
<b>FULL ONE-YEAR WARRANTY</b> From Date of Purchase	FSP® replacement parts and repair labor to correct defects in materials or workmanship. Service must be provided by an authorized Whirlpool® service company.
<b>LIMITED FOUR-YEAR WARRANTY</b> Second Through Fifth Year From Date of Purchase	FSP® replacement magnetron tube on microwave ovens if defective in materials or workmanship.
<b>WHIRLPOOL WILL NOT PAY FOR</b>	
<p><b>A. Service calls to:</b></p> <ol style="list-style-type: none"> <li>1. Correct the installation of the microwave oven.</li> <li>2. Instruct you how to use the microwave oven.</li> <li>3. Replace house fuses or correct house wiring.</li> <li>4. Replace owner accessible light bulbs.</li> </ol> <p><b>B. Repairs when microwave oven is used in other than normal, single-family household use.</b></p> <p><b>C. Pickup and delivery.</b> This product is designed to be repaired in the home.</p> <p><b>D. Damage to microwave oven caused by accident, misuse, fire, flood, acts of God or use of products not approved by Whirlpool.</b></p> <p><b>E. Any labor costs during limited warranty.</b></p> <p><b>F. Repairs to parts or systems caused by unauthorized modifications made to the appliance.</b></p>	

8-82

WHIRLPOOL CORPORATION SHALL NOT BE LIABLE FOR INCIDENTAL OR CONSEQUENTIAL DAMAGES. Some states do not allow the exclusion or limitation of incidental or consequential damages, so this limitation or exclusion may not apply to you. This warranty gives you specific legal rights, and you may also have other rights which vary from state to state.

Outside the United States, a different warranty may apply. For details, please contact your authorized Whirlpool distributor or military exchange.

If you need service, first see the "Assistance or Service" section of this book. After checking "Assistance or Service," additional help can be found by calling our Consumer Assistance Center telephone number, **1-800-253-1301**, from anywhere in the U.S.