

# GAS BUILT-IN SINGLE & DOUBLE OVENS

*MODELS (singles):*

KGBS145S

GBO-2453

*MODELS (doubles):*

KGBS245S

GBO-2463

# INSTALLATION INSTRUCTIONS

## INSTALLER: FINAL CHECK LIST

### PLACEMENT OF UNIT

- 1. Properly positioned – level, aligned and square with cabinet opening.
- 2. Anchored securely to cabinet.
- 3. Oven not placed under countertop or microwave oven.

### ELECTRICAL

- 1. Oven properly grounded.
- 2. Polarized three wire 120 VAC, 15 Ampere receptacle with 15 ampere overcurrent protection provided for service cord connection.

### GAS SUPPLY

- 1. Supply line of 3/8" black iron pipe provided.
- 2. Manual gas shutoff valve installed in accessible location.
- 3. Oven tested for gas leaks.

### OPERATIONAL

- 1. If used on LP gas, verify that pressure regulator and orifice hoods have been modified for use with LP gas.
- 2. Oven racks installed and slide freely in all positions.
- 3. Knobs secured in place and rotate freely without rubbing on edge of control panel glass holes.
- 4. Selector switch functions in all modes.
- 5. All lights function properly.
- 6. Clock timer buzzer operates.
- 7. Doors properly adjusted, open and close smoothly.
- 8. Unless instructed to leave for owner, remove all tags, labels and internal packing material.
- 9. Oven has been wiped clean to remove fingerprints and other smudges.

## THANK YOU INSTALLER:

1. Complete Installation Check List.
2. Leave all literature for customer.
3. Notify dealer that installation is completed.

**FOR DETAILED INSTRUCTIONS, FOLLOW METHODS DESCRIBED IN THIS FOLDER.**

**IMPORTANT: Read Before Installing to Save Time, Work, assure proper performance, and owner's warranty protection.**

# INSTALLATION INSTRUCTIONS

The installation of the oven must conform to local codes and utility regulations and should be made only by a competent technician. In the absence of local codes, the installation must conform with the National Fuel Gas Code, ANSI Z223.1-1984. When installed, the appliance must be electrically grounded in accordance with local codes, or in the absence of local codes, with the National Electrical Code, ANSI/NFPA No. 70-1987. When the oven is installed in a mobile home, the installation must conform with the Federal Standard for Mobile Home Construction and Safety, Title 24 HUD (Part 280) or, when such Standard is not applicable, with local codes.

## CABINET CONSTRUCTION

The cabinet must completely enclose the oven. An access panel or doors should be provided in the cabinet below the oven to allow access to the electrical outlet and manual gas shut off valve required for installation. Refer to illustration below for correct location and dimensions to use.

The recommended cabinet should have two runners on nineteen and one-half inches (19½") centers with a minimum opening between the runners of sixteen inches (16"). These runners must be solid enough to support the weight of the unit. The double unit weighs approximately 260 pounds. Be sure that the runners are level and straight. There are no provisions for leveling the unit once it is installed. If the oven is not installed level, it will not cook properly.

The inlet for the gas supply line and opening for the electric supply cord are located at the rear under the unit as shown at right.

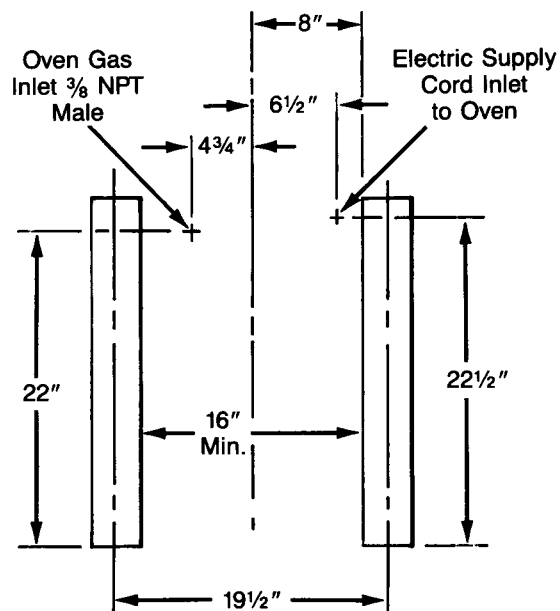

FRONT OF CABINET

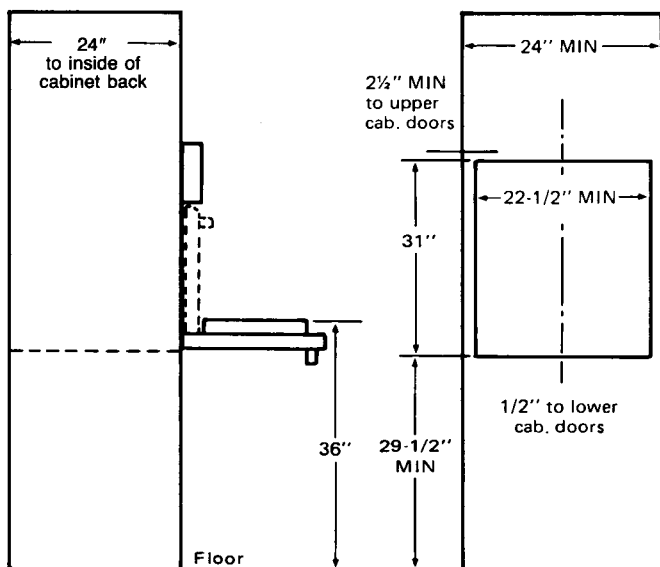

**SINGLE OVENS**  
KGBS145S  
GBO-2453

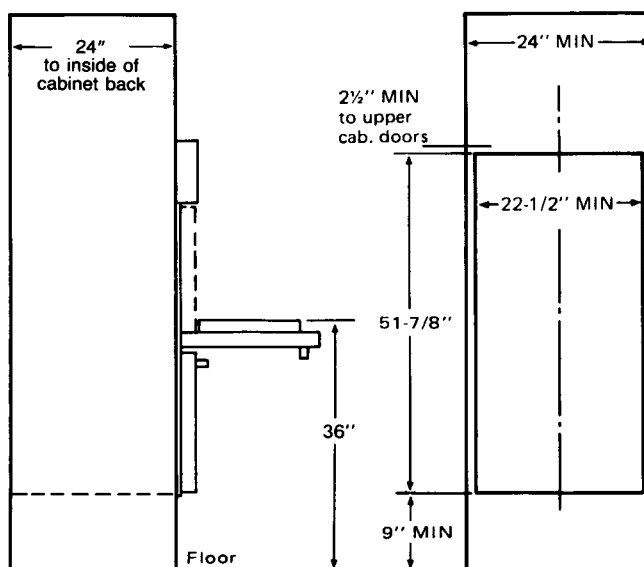

**DOUBLE OVENS**  
KGBS245S  
GBO-2463

## ELECTRICAL

The oven requires a polarized three wire grounded receptacle to a 120 VAC, 60 Hz 15 amp overcurrent protected circuit. The receptacle should be installed below the oven and be easily accessible for removal of the oven service cord from the receptacle for servicing of the oven. If such an outlet is not available, have a qualified electrician change your present outlet or install a new one.

As a temporary measure, a grounding adapter plug may be used to convert a two hole outlet to a three hole outlet. It may be used only if the outlet is properly polarized and grounding. Have a qualified electrician verify that the outlet meets all requirements.

PLUG WITH GROUND PRONG  
PROPERLY POLARIZED AND  
GROUNDED RECEPTACLE

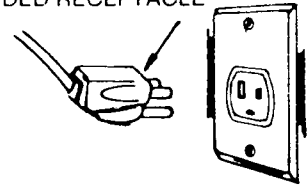

## UNPACKING THE UNIT

**WARNING: THIS OVEN IS PROVIDED WITH A THREE-PRONG GROUNDING PLUG. IT IS IMPERATIVE THAT THE OUTLET TO WHICH THIS PLUG IS CONNECTED BE PROPERLY GROUNDED. IF THE RECEPTACLE IS NOT THE PROPER GROUNDING TYPE, A QUALIFIED ELECTRICIAN SHOULD BE CONTACTED.**

Prior to installation, test the electrical service to assure that it agrees with the specifications on the oven data plate.

The oven should be left on the carton base until it is ready to put into the cabinet. It is also recommended that the pad(s) over the door(s) be left in place. These precautions will reduce the possibility of damage to the front of the unit and the bottom of the front frame.

Remove all cards, tape and wire used to hold various parts in position during shipment. Study all labels and follow their instructions during shipment.

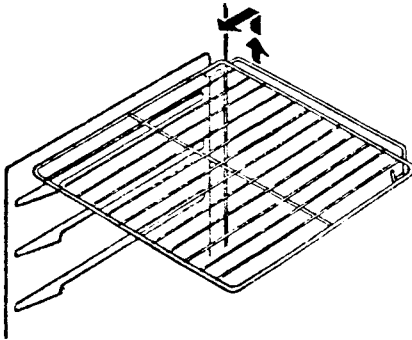

### To remove oven racks

1. Slide rack all the way to the back of the oven.
2. Lift the back of the rack up above the rack guides.
3. Pull forward to remove.

## GAS SUPPLY CONSTRUCTION

A manual shut-off valve accessible from the front of the oven is provided. This valve will allow the gas to be turned off when it is not necessary to completely remove the oven from the cabinet for service.

It is suggested that an approved flexible gas line be installed between the gas supply line and the oven inlet pipe. The flexible line should be long enough to allow the oven to slide forward approximately 10 inches for service. This line must be free from binding on the cabinet runners.

To provide for complete removal of the oven from the cabinet, it is recommended that a second manual shut-off (supplied by installer) be installed. It should be located in an accessible location between the rigid and flexible gas supply lines to the unit.

All gas supply connections should be made by a qualified technician and in accordance with local codes or ordinances. In the absence of a local code, the installation must conform to the National Fuel Gas Code ANSI Z2231-1984. Apply a thread sealant resistant to natural and LP gases on all threaded gas connections.

## INSTALLING THE UNIT IN CABINET

Route electric supply cord so that it can be plugged into receptacle after unit has been slid into place in cabinet.

The doors should be removed to decrease the weight of the oven and provide a better hand hold on the oven while lifting it into the cabinet.

### A. TO REMOVE DOORS (See Illus.)

Use caution! Oven door is heavy.

1. Open door completely.
2. Depress finger tab in oven door hinge area. Push tab toward oven. Lift tab away from door liner and slide toward top of oven door.
3. Repeat step 2 for other side of door.
4. Close door until approximately 5 inches from fully closed position.
5. Slide door off the hinge arm assemblies.
6. Repeat steps 1 through 5 for other door on double ovens.

**BE SURE THAT MICA SPACERS AT EITHER SIDE OF OVEN ARE IN PLACE TO PROVIDE PROPER AIR FLOW BETWEEN CABINET AND OVEN.**

When oven has been placed into cabinet, the bottom trim strip is placed on the lower edge of the front frame. This is done by loosening the three screws at the bottom of the front frame. Place gas valve extension rod through hole in trim strip and slide strip under screw heads until the top edge of trim meets the lower corners of the front frame (see Illus.). Tighten screws to hold trim to front frame. Make sure that valve is turned to the full "on" position (pin straight and down).

**Secure oven to cabinet with #8 screws provided. Do not overtighten screws. Edge of front frame should be parallel to cabinet. Disregard any excess screws that are left after all screw holes in front frame have been used.**

### B. REPLACE OVEN RACKS IN OVEN CAVITY.

### C. REINSTALL THE DOOR(S) (See Illus.)

1. Slide door hinge arms until firmly seated.
2. Lower door to full open position.
3. Push finger tabs to back. Depress the tabs and slide forward.
4. Close and reopen door slowly to make sure it has been replaced properly.
5. Repeat steps 1 through 4 for other door on double oven.

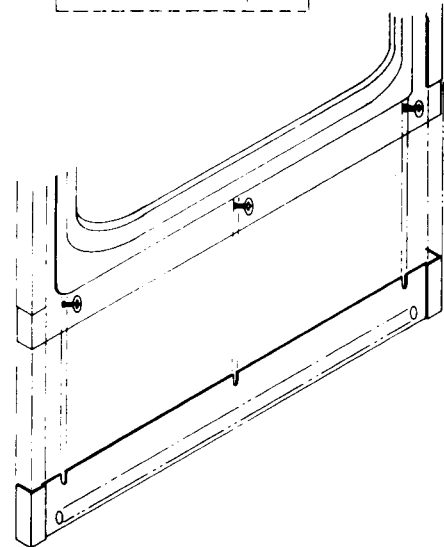
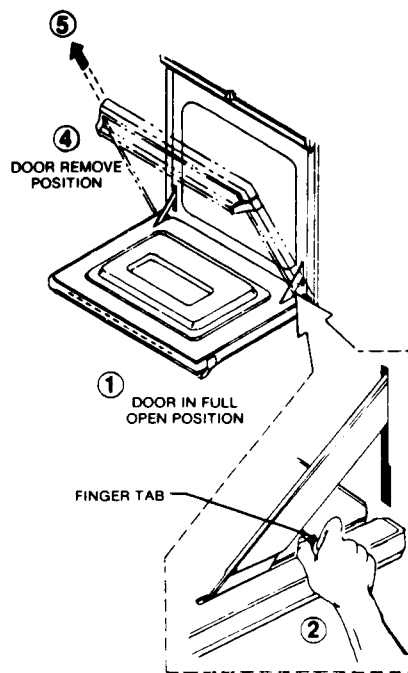

## CHECKOUT AND ADJUSTMENT

After the oven is installed and the gas connected, all gas connections should be tested for gas leaks. Be sure that electricity is "off" before turning on the gas supply. Test with pressure gauge or apply soapy solution or leak detector solution on ALL gas connections. Repair any leaks that may appear before placing the oven in operation.

**THE REGULATOR IS SET FOR USE WITH NATURAL GAS. FOR USE WITH LP GAS, THE REGULATOR MUST BE CONVERTED.** The gas pressure regulator is located in the compartment behind the control frame. Remove control frame (see instructions below), loosen and slide the control mounting plate out to gain access to the pressure regulator.

## TO REMOVE CONTROL FRAME

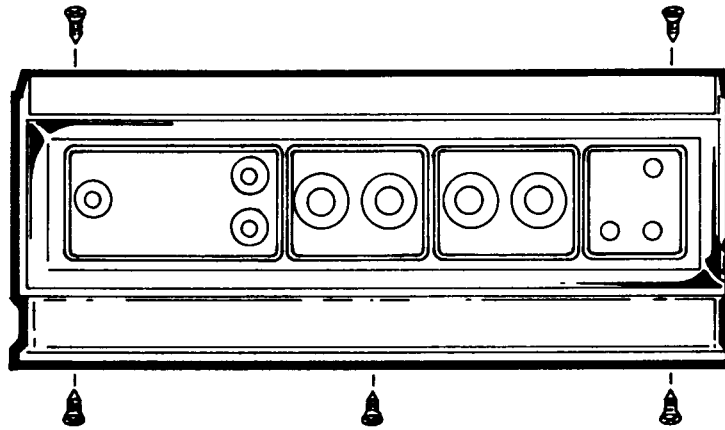

1. Remove bezel nuts from oven light and panel light switches by turning counterclockwise.
2. Remove all other knobs by pulling straight forward.
3. Remove front 3 Phillips screws under control frame and 2 Phillips screws on top portion of control frame. Be sure to hold control frame in place.
4. Pull control frame forward.

To convert the regulator for LP gas, remove the regulator access cap (see below). Reverse cap, so that "LP" in cap recess is showing when cap is in place. Return cap to regulator and tighten. The regulator is set at 4" water column (W.C.) for use with natural gas and 10" W.C. for use with LP gases. In order to check pressure regulator, the inlet test pressure must be at least one (1") W.C. greater (5" for natural and 11" for LP) than setting. Maximum pressure to regulator must not exceed 14" W.C.

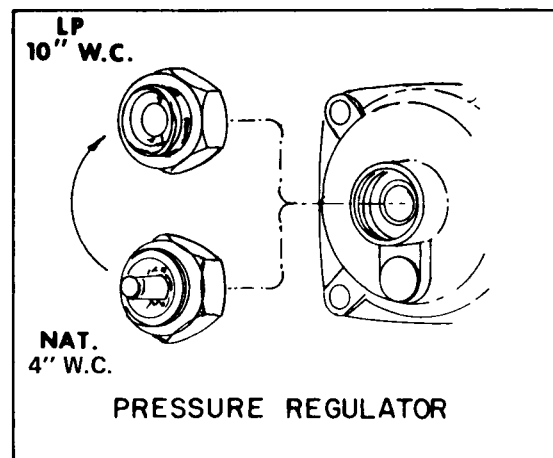

The appliance and its individual shutoff valve must be disconnected from the gas supply piping system during any pressure testing of that system at test pressures in excess of ½ psig.

The appliance must be isolated from the gas supply piping system by closing its individual manual shutoff valve during any pressure testing of the gas supply piping system at test pressures equal to or less than ½ psig.

This unit may be used on natural or LP gas. A basic adjustment has been made at the factory for natural gas.

WHEN USED WITH LP GASES: MAKE CERTAIN THAT PRESSURE REGULATOR HAS BEEN CONVERTED FOR USE WITH LP GAS. ADJUST BURNER INPUT BY TURNING OUTER ORIFICE HOODS DOWN UNTIL SNUG AGAINST INNER ORIFICE NEEDLE.

Final adjustment of the air-gas mixture is made by turning the air shutter until a concise blue cone has been obtained. If the flames lift from the burner, reduce the air opening in the shutter. If the flames are yellow, increase the air shutter opening.

**WARNING: DO NOT UNDER ANY CIRCUMSTANCES CUT OR REMOVE GROUNDING PRONG FROM RANGE CORD. FAILURE TO PROVIDE PROPER POLARIZATION MAY CREATE A HAZARDOUS CONDITION.**

### DOOR ADJUSTMENT CHECK

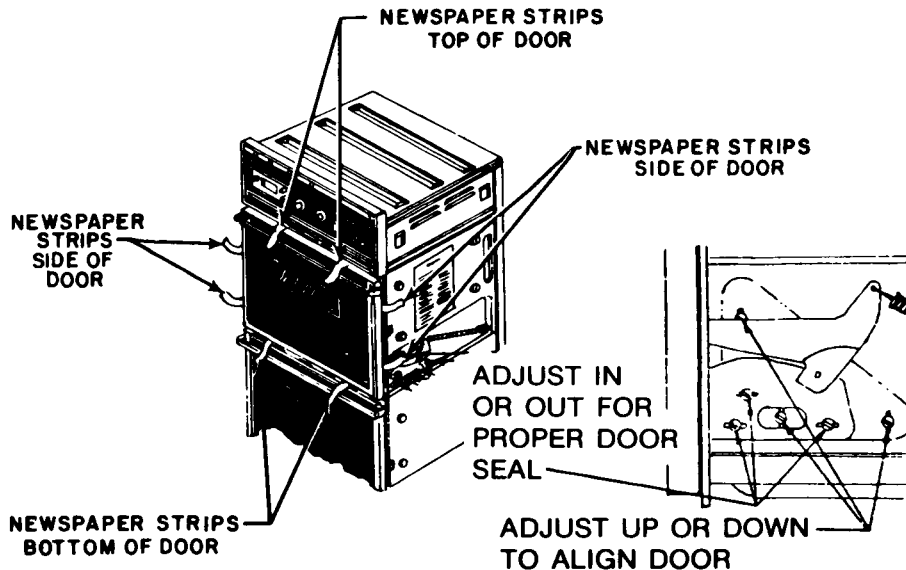

Place 2" x 18" strips of newspaper in locations indicated by illustration. Allow one end of the paper to extend into the oven cavity. Pull gently at each piece of paper. If door is properly adjusted, each piece of paper will offer firm resistance when pulled. When door is out of adjustment, slide unit out far enough to expose hinges on each side (see preceding page). Loosen screws and move bottom of door to a proper fit. After completing adjustment tighten all screws in hinges.

# SCHEMATIC DIAGRAM

KGBS145S

KGBS245S

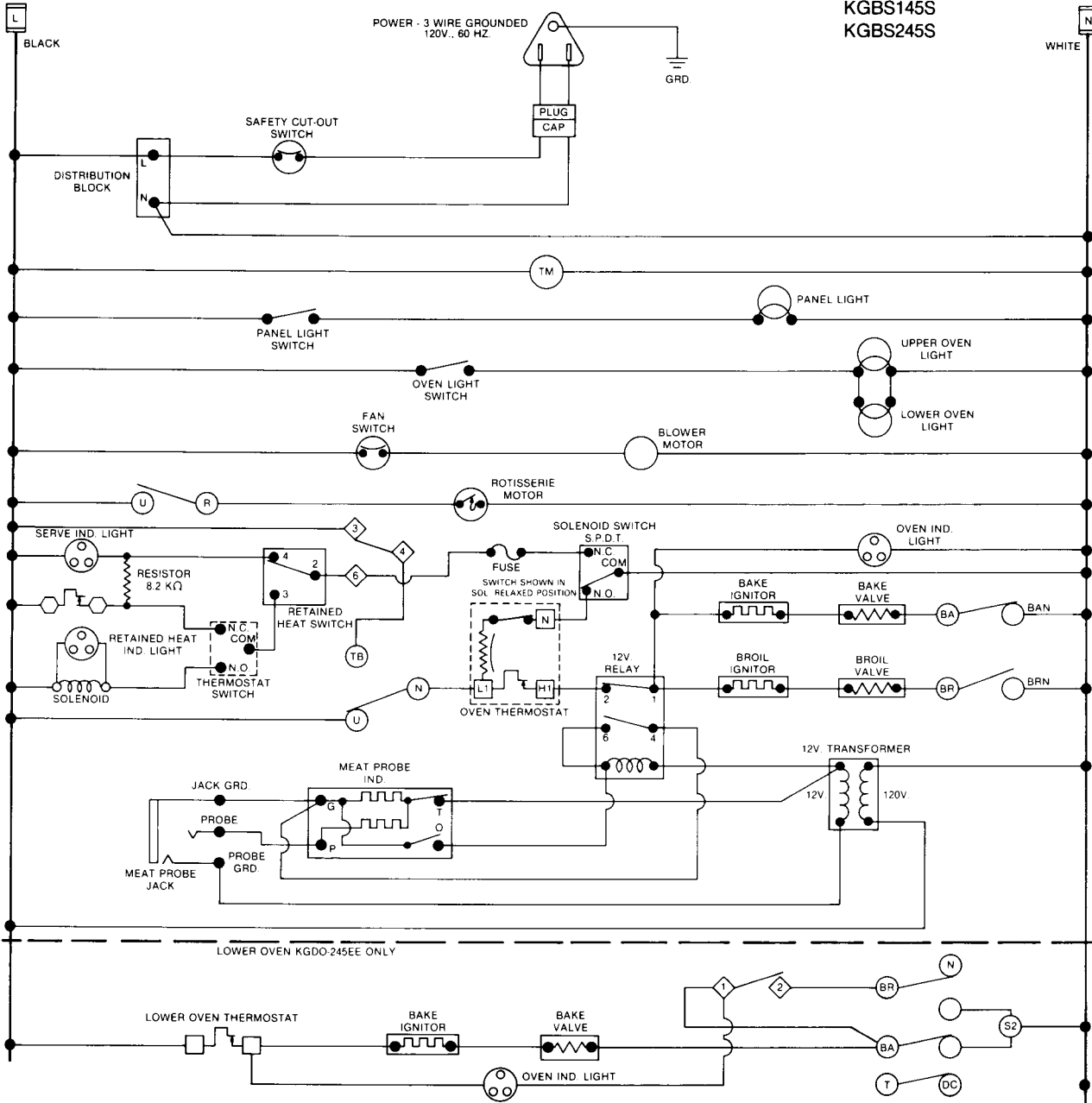

LOWER OVEN KGDO-245EE ONLY

SYMBOLS	
	SELECTOR SWITCH
	THERMOSTAT
	CLOCK SWITCH
	RETAINED HEAT THERMOSTAT

L/O SELECTOR OPERATION	T BR BA			
	DC	N	S2	S2
OFF	O	O	O	O
BAKE	X	X	O	X
TIME BAKE	X	O	X	O

X = CLOSED      O = OPEN

L/O SELECTOR OPERATION	BAN R BRN					
	BA	U	TE	U	BR	
OFF	O	O	O	O	O	O
ROTISS	O	X	O	X	X	
BROIL	O	X	O	O	X	
BAKE	X	X	O	O	O	
TIME BAKE	X	O	X	O	O	

X = CLOSED      O = OPEN

CLOCK SWITCH OPERATION	
UPPER OVEN	
DELAY	NONE
TIMED BAKE	3-4
RT. HT./SERVE	4-6
LOWER OVEN	
DELAY	NONE
TIMED BAKE	1-2

PL-19445-1

MADE UNDER ONE OR MORE OF THE FOLLOWING U.S. PATENTS:  
 3,967,164      4,161,939      4,163,894      4,194,321  
 4,214,571      4,250,865      4,163,344      4,295,261

# SCHEMATIC DIAGRAM

## GBO-2453 GBO-2463

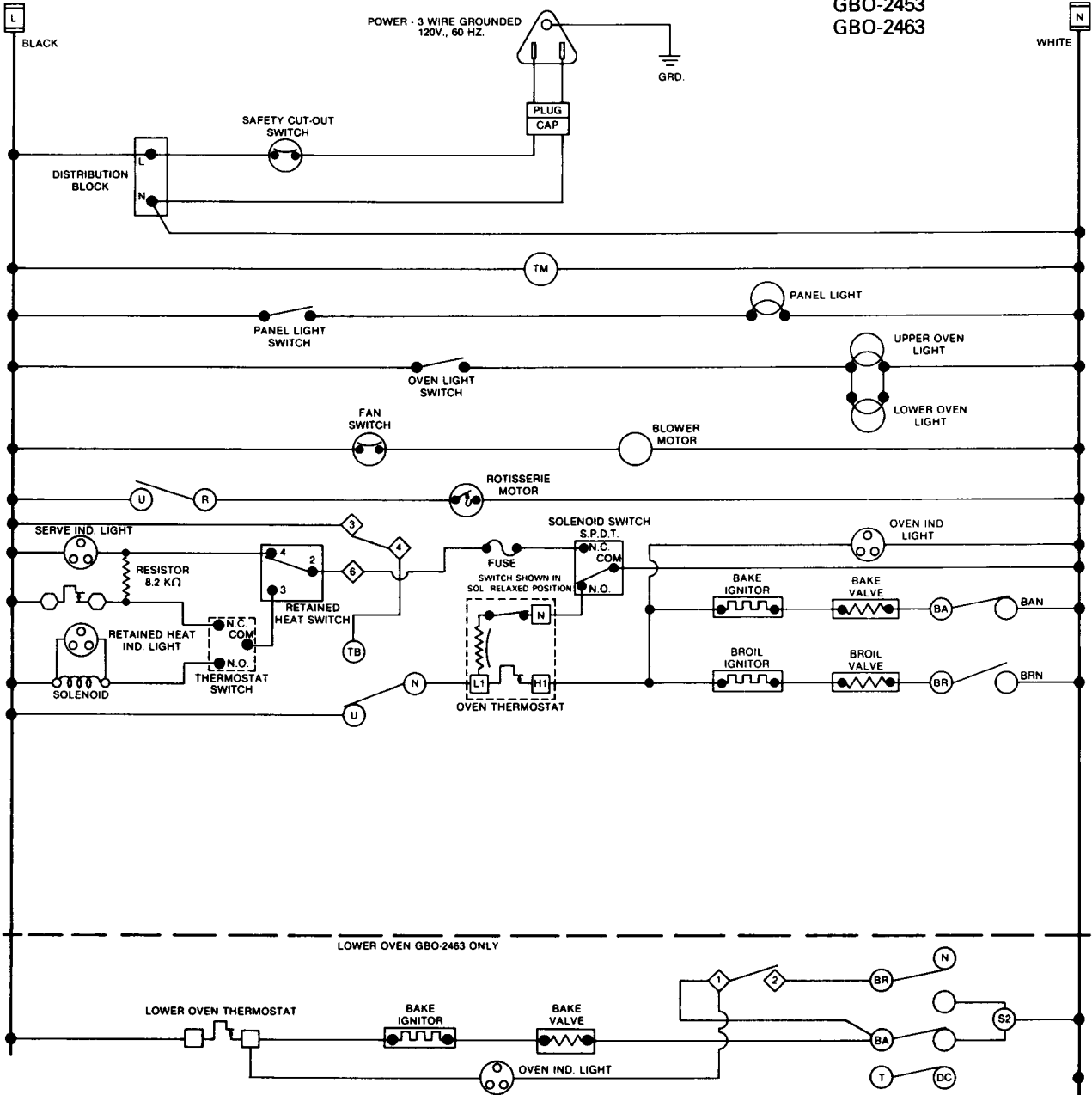

SYMBOLS	
	SELECTOR SWITCH
	THERMOSTAT
	CLOCK SWITCH
	RETAINED HEAT THERMOSTAT

SWITCH POSITION	L/O SELECTOR OPERATION			
	T	BR	BA	
OFF	O	O	O	O
BAKE	X	X	O	X
TIME BAKE	X	O	X	O

X = CLOSED    O = OPEN

SWITCH POSITION	L/O SELECTOR OPERATION					
	BAN	N	R	BRN		
OFF	O	O	O	O	O	O
ROTIS	O	X	O	X	X	X
BROIL	O	X	O	O	O	X
BAKE	X	X	O	O	O	O
TIME BAKE	X	O	X	O	O	O

X = CLOSED    O = OPEN

CLOCK SWITCH OPERATION	
UPPER OVEN	
DELAY	NONE
TIMED BAKE	3-4
RT. HT./SERVE	4-6
LOWER OVEN	
DELAY	NONE
TIMED BAKE	1-2

PL-19445-2



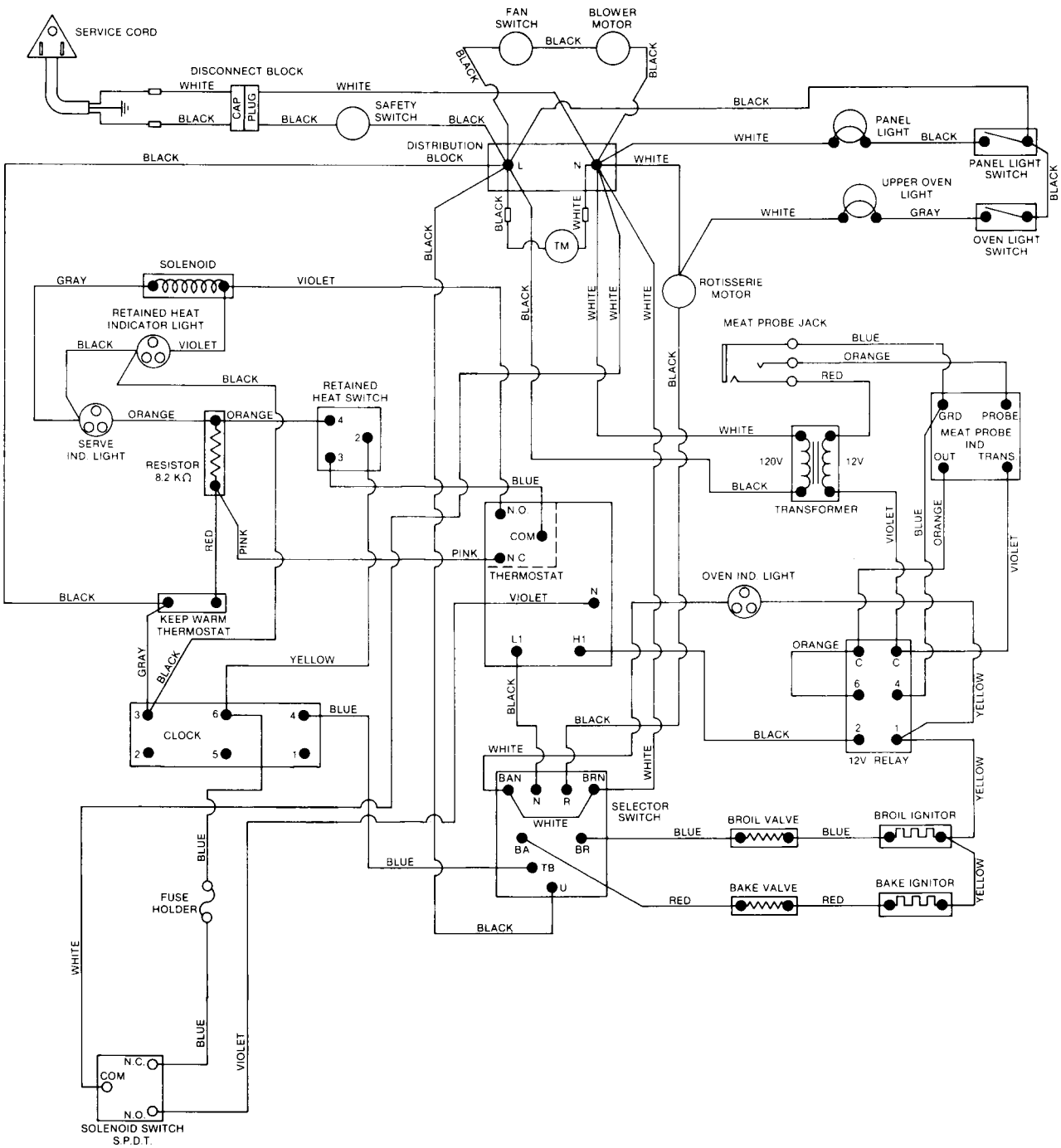

SINGLE OVEN HOOKUP  
KGBS145S

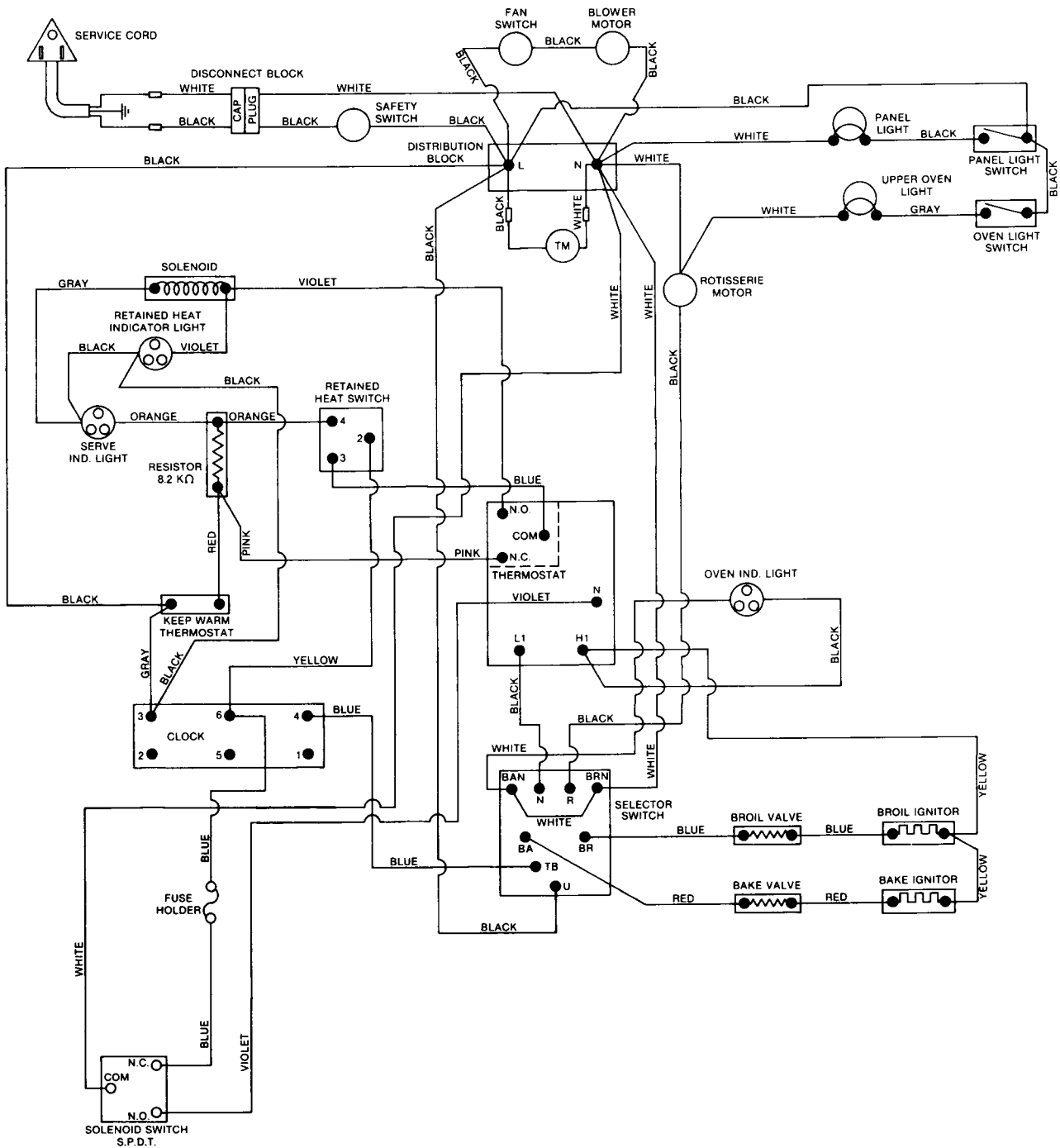

SINGLE OVEN HOOKUP  
 GBO-2453

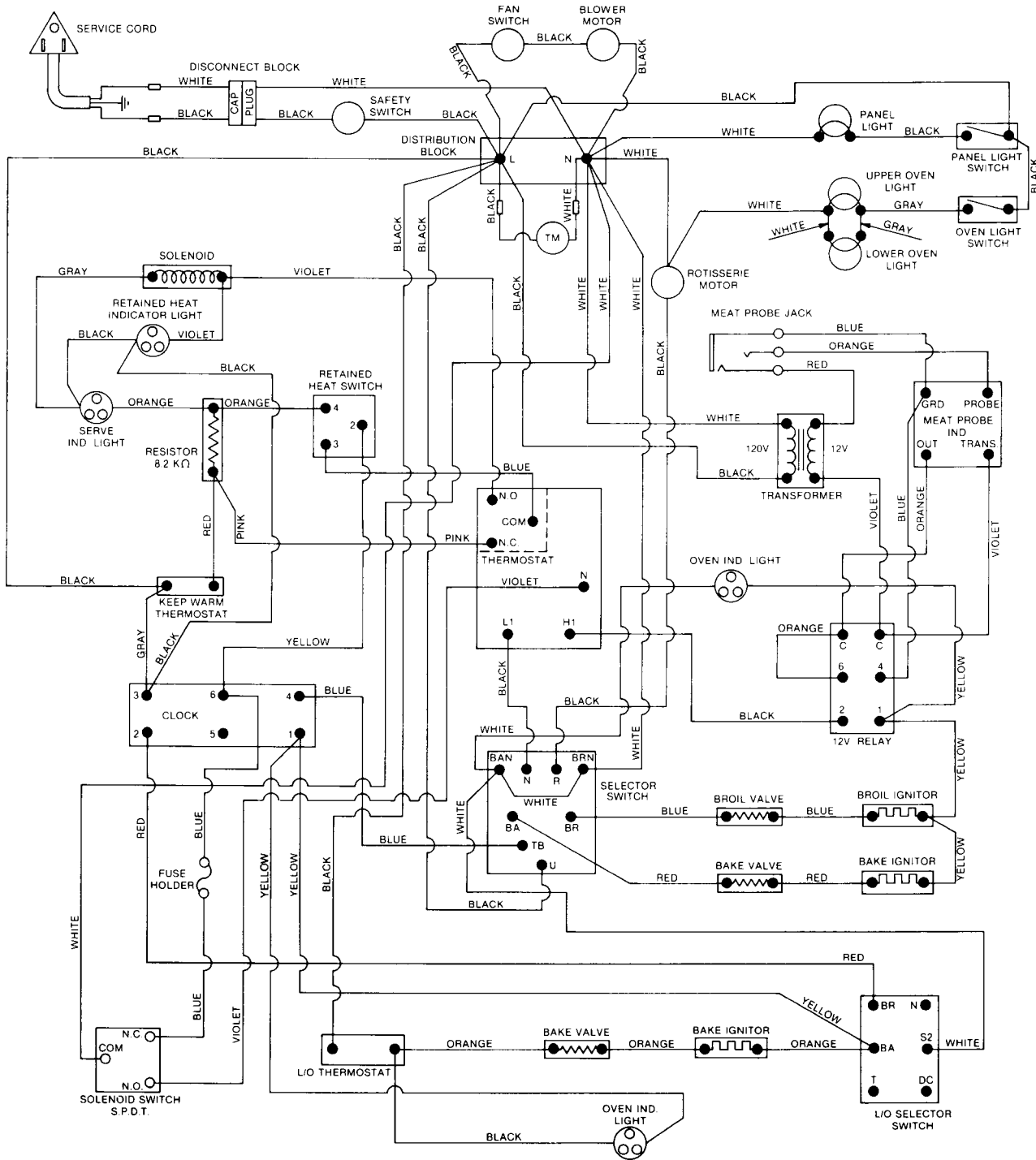

DOUBLE OVEN HOOKUP  
KGBS245S

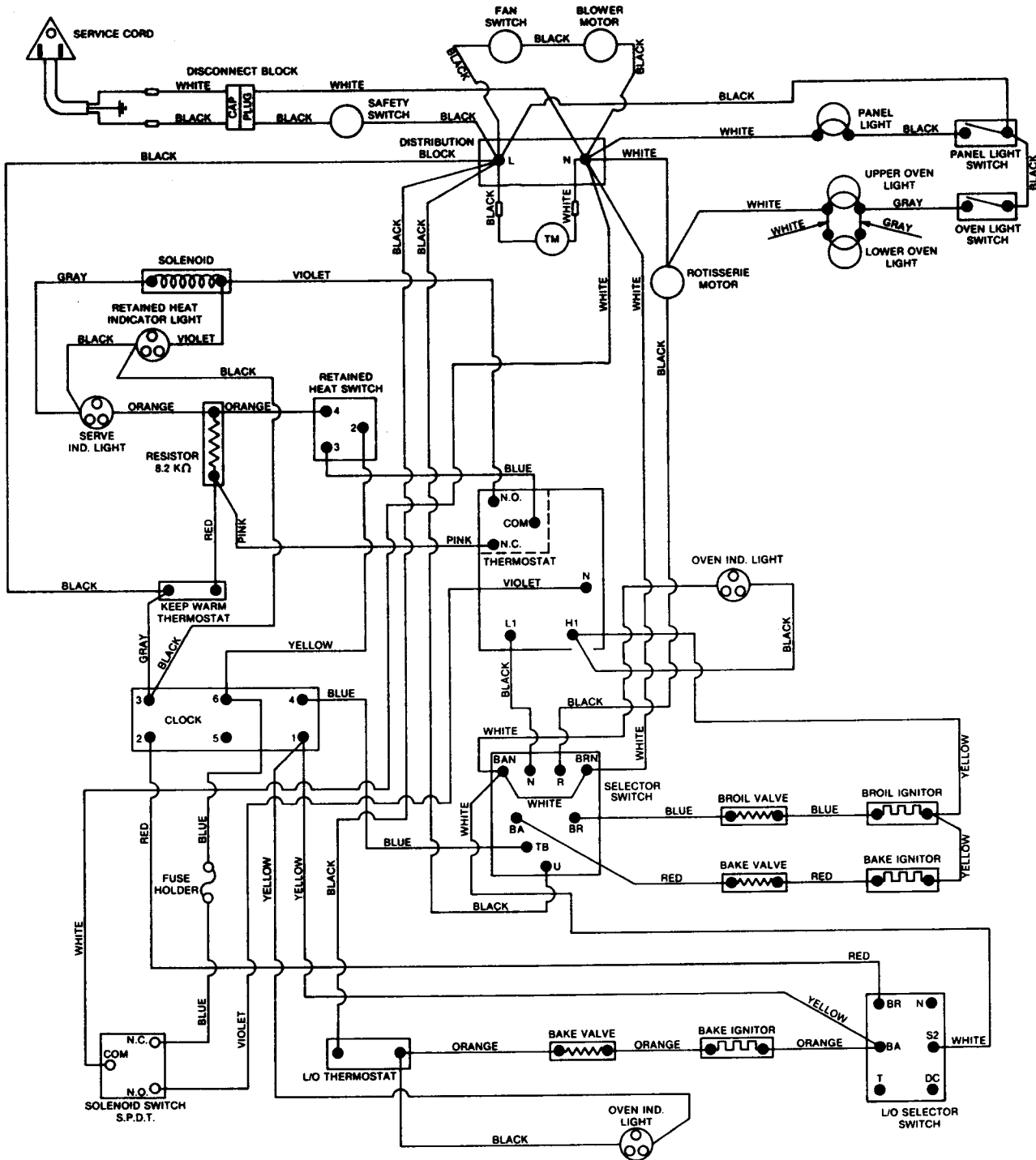

DOUBLE OVEN HOOKUP  
GBO-2463