

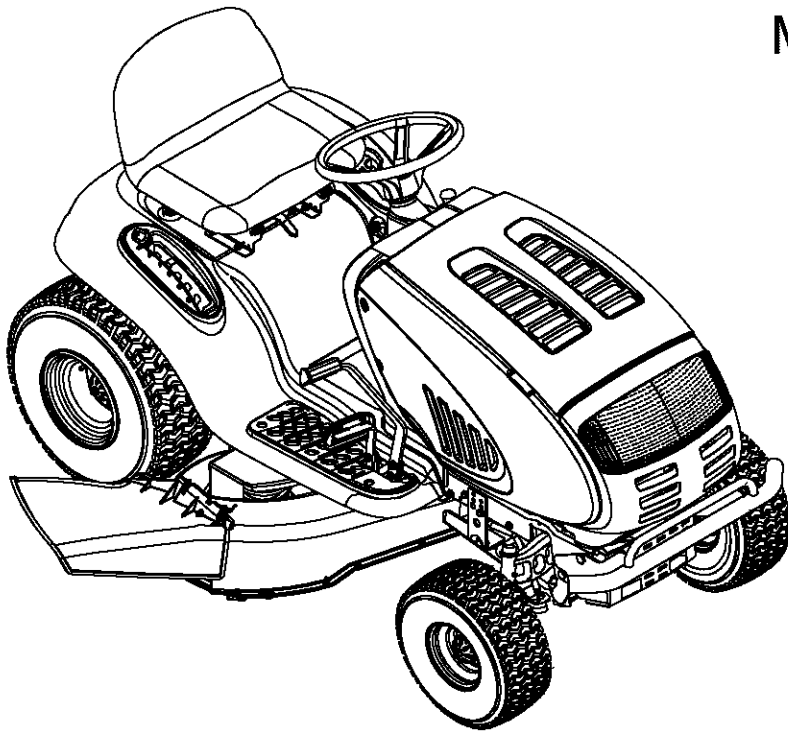

Operator's Manual

Pedal Drive Lawn Tractor
Models J609H
Y609H



IMPORTANT: READ SAFETY RULES AND INSTRUCTIONS CAREFULLY

Warning: This unit is equipped with an internal combustion engine and should not be used on or near any unimproved forest-covered, brush-covered or grass-covered land unless the engine's exhaust system is equipped with a spark arrester meeting applicable local or state laws (if any). If a spark arrester is used, it should be maintained in effective working order by the operator. In the State of California the above is required by law (Section 4442 of the California Public Resources Code). Other states may have similar laws. Federal laws apply on federal lands. A spark arrester for the muffler is available through your nearest engine authorized service dealer or contact the service department, P.O. Box 368022 Cleveland, Ohio 44136-9722.

MTD PRODUCTS INC. P.O. BOX 368022 CLEVELAND, OHIO 44136-9722

TROY-BILT® is a registered trademark owned by Garden Way Incorporated of Troy, New York.

PRINTED IN U.S.A.

FORM NO. 770-10491A
(3/2001)

SECTION 1: IMPORTANT SAFE OPERATION PRACTICES



WARNING: This symbol points out important safety instructions which, if not followed, could endanger the personal safety and/or property of yourself and others. Read and follow all instructions in this manual before attempting to operate this machine. Failure to comply with these instructions may result in personal injury. When you see this symbol—heed its warning.



DANGER: This machine was built to be operated according to the rules for safe operation in this manual. As with any type of power equipment, carelessness or error on the part of the operator can result in serious injury. This machine is capable of amputating hands and feet and throwing objects. Failure to observe the following safety instructions could result in serious injury or death.

California Proposition 65 Warning:



WARNING: Engine exhaust, some of its constituents, and certain vehicle components contain or emit chemicals known to the State of California to cause cancer and birth defects or other reproductive harm.

GENERAL OPERATION

1. Read, understand, and follow all instructions on the machine and in the manual(s) before attempting to assemble and operate. Keep this manual in a safe place for future and regular reference and for ordering replacement parts.
2. Be familiar with all controls and their proper operation. Know how to stop the machine and disengage them quickly.
3. Never allow children under 14 years old to operate this machine. Children 14 years old and over should read and understand the operation instructions and safety rules in this manual and should be trained and supervised by a parent.
4. Never allow adults to operate this machine without proper instruction.
5. To help avoid blade contact or a thrown object injury, keep bystanders, helpers, children and pets at least 75 feet from the machine while it is in operation. Stop machine if anyone enters the area.
6. Thoroughly inspect the area where the equipment is to be used. Remove all stones, sticks, wire, bones, toys, and other foreign objects which could be picked up and thrown by the blade(s). Thrown objects can cause serious personal injury.
7. Plan your mowing pattern to avoid discharge of material toward roads, sidewalks, bystanders and the like. Also, avoid discharging material against a wall or obstruction which may cause discharged material to ricochet back toward the operator.
8. Always wear safety glasses or safety goggles during operation and while performing an adjustment or repair to protect your eyes. Thrown objects which ricochet can cause serious injury to the eyes.
9. Wear sturdy, rough-soled work shoes and close-fitting slacks and shirts. Loose fitting clothes and jewelry can be caught in movable parts. Never operate this machine in bare feet or sandals.
10. Be aware of the mower and attachment discharge direction and do not point it at anyone. Do not operate the mower without the discharge cover or entire grass catcher in its proper place.
11. Do not put hands or feet near rotating parts or under the cutting deck. Contact with the blade(s) can amputate hands and feet.
12. A missing or damaged discharge cover can cause blade contact or thrown object injuries.
13. Stop the blade(s) when crossing gravel drives, walks, or roads and while not cutting grass.
14. Watch for traffic when operating near or crossing roadways. This machine is not intended for use on any public roadway.
15. Do not operate the machine while under the influence of alcohol or drugs.
16. Mow only in daylight or good artificial light.
17. Never carry passengers.
18. Disengage blade(s) before shifting into reverse. Back up slowly. Always look down and behind before and while backing to avoid a back-over accident.
19. Slow down before turning. Operate the machine smoothly. Avoid erratic operation and excessive speed.
20. Disengage blade(s), set parking brake, stop engine and wait until the blade(s) come to a complete stop before removing grass catcher, emptying grass, unclogging chute, removing any grass or debris, or making any adjustments.
21. Never leave a running machine unattended. Always turn off blade(s), place transmission in neutral, set parking brake, stop engine and remove key before dismounting.
22. Use extra care when loading or unloading the machine into a trailer or truck. This unit should not be driven up or down ramp(s), because the unit could tip over, causing serious personal injury. The unit must be pushed manually on ramp(s) to load or unload properly.

23. Muffler and engine become hot and can cause a burn. Do not touch.
24. Check overhead clearances carefully before driving under low hanging tree branches, wires, door openings etc., where the operator may be struck or pulled from the unit, which could result in serious injury.
25. Disengage all attachment clutches, depress the brake pedal completely and shift into neutral before attempting to start engine.
26. Your machine is designed to cut normal residential grass of a height no more than 10". Do not attempt to mow through unusually tall, dry grass (e.g., pasture) or piles of dry leaves. Dry grass or leaves may contact the engine exhaust and/or build up on the mower deck presenting a potential fire hazard.
27. Use only accessories and attachments approved for this machine by the machine manufacturer. Read, understand and follow all instructions provided with the approved accessory or attachment.
28. Data indicates that operators, age 60 years and above, are involved in a large percentage of riding mower-related injuries. These operators should evaluate their ability to operate the riding mower safely enough to protect themselves and others from serious injury.
29. If situations occur which are not covered in this manual, use care and good judgment. Contact an authorized MTD Service Dealer for assistance.

SLOPE OPERATION

Slopes are a major factor related to loss of control and tip-over accidents which can result in severe injury or death. All slopes require extra caution. If you cannot back up the slope or if you feel uneasy on it, do not mow it.

For your safety, use the slope gauge included as part of this manual to measure slopes before operating this unit on a sloped or hilly area. If the slope is greater than 15 degrees as shown on the slope gauge, do not operate this unit on that area or serious injury could result.

DO:

1. Mow up and down slopes, not across. Exercise extreme caution when changing direction on slopes.
2. Watch for holes, ruts, bumps, rocks, or other hidden objects. Uneven terrain could overturn the machine. Tall grass can hide obstacles.
3. Use slow speed. Choose a low enough speed setting so that you will not have to stop or shift while on the slope. Tires may lose traction on slopes even though the brakes are functioning properly. Always keep machine in gear when going down slopes to take advantage of engine braking action.
4. Follow the manufacturer's recommendations for wheel weights or counterweights to improve stability.
5. Use extra care with grass catchers or other attachments. These can change the stability of the machine.
6. Keep all movement on the slopes slow and gradual. Do not make sudden changes in speed or direction. Rapid engagement or braking could cause the front of the machine to lift and rapidly flip over backwards which could cause serious injury.
7. Avoid starting or stopping on a slope. If tires lose traction, disengage the blade(s) and proceed slowly straight down the slope.

DO NOT:

1. Do not turn on slopes unless necessary; then, turn slowly and gradually downhill, if possible.
2. Do not mow near drop-offs, ditches or embankments. The mower could suddenly turn over if a wheel is over the edge of a cliff, ditch, or if an edge caves in.
3. Do not try to stabilize the machine by putting your foot on the ground.
4. Do not use a grass catcher on steep slopes.
5. Do not mow on wet grass. Reduced traction could cause sliding.
6. Do not shift to neutral and coast downhill. Over-speeding may cause the operator to lose control of the machine resulting in serious injury or death.
7. Do not tow heavy pull behind attachments (e.g. loaded dump cart, lawn roller, etc.) on slopes greater than 5 degrees. When going down hill, the extra weight tends to push the tractor and may cause you to lose control. (e.g. tractor may speed up, braking and steering ability are reduced, attachment may jack-knife and cause tractor to overturn).

CHILDREN

1. Tragic accidents can occur if the operator is not alert to the presence of children. Children are often attracted to the machine and the mowing activity. They do not understand the dangers. Never assume that children will remain where you last saw them.
 - a. Keep children out of the mowing area and in watchful care of a responsible adult other than the operator.
 - b. Be alert and turn machine off if a child enters the area.
 - c. Before and while backing, look behind and down for small children.
 - d. Never carry children, even with the blade(s) shut off. They may fall off and be seriously injured or interfere with safe machine operation.

- e. Use extreme care when approaching blind corners, doorways, shrubs, trees or other objects that may block your vision of a child who may run into the machine.
 - f. Disengage the cutting blade(s) before shifting in reverse. The “No-Cut-In Reverse” feature is a reminder not to cut in reverse and to help avoid back over accidents. Do not defeat it.
 - g. Keep children away from hot or running engines. They can suffer burns from a hot muffler.
 - h. Remove key when machine is unattended to prevent unauthorized operation.
9. Never allow children under 14 years old to operate the machine. Children 14 years old and over should read and understand the operation instructions and safety rules in this manual and should be trained and supervised by a parent.

TOWING

1. Tow only with a machine that has a hitch designed for towing. Do not attach towed equipment except at the hitch point.
2. Follow the manufacturers recommendation for weight limits for towed equipment and towing on slopes.
3. Never allow children or others in or on towed equipment.
4. On slopes, the weight of the towed equipment may cause loss of traction and loss of control.
5. Travel slowly and allow extra distance to stop.
6. Do not shift to neutral and coast downhill.

SERVICE

SAFE HANDLING OF GASOLINE:

1. **To avoid personal injury or property damage** use extreme care in handling gasoline. **Gasoline** is extremely flammable and the vapors are explosive. Serious personal injury can occur when gasoline is spilled on yourself or your clothes which can ignite. Wash your skin and change clothes immediately.
 - a. Use only an approved gasoline container.
 - b. Never fill containers inside a vehicle or on a truck or trailer bed with a plastic liner. Always place containers on the ground away from your vehicle before filling.
 - c. When practical, remove gas-powered equipment from the truck or trailer and refuel it on the ground. If this is not possible, then refuel such equipment on a trailer with a portable container, rather than from a gasoline dispenser nozzle.
 - d. Keep the nozzle in contact with the rim of the fuel tank or container opening at all times until fueling is complete. Do not use a nozzle lock-open device.

- e. Extinguish all cigarettes, cigars, pipes and other sources of ignition.
- f. Never fuel machine indoors.
- g. Never remove gas cap or add fuel while the engine is hot or running. Allow engine to cool at least two minutes before refueling.
- h. Never over fill fuel tank. Fill tank to no more than ½ inch below bottom of filler neck to allow space for fuel expansion.
- i. Replace gasoline cap and tighten securely.
- j. If gasoline is spilled, wipe it off the engine and equipment. Move unit to another area. Wait 5 minutes before starting the engine.
- k. To reduce fire hazards, keep machine free of grass, leaves, or other debris build-up. Clean up oil or fuel spillage and remove any fuel soaked debris.
- l. Never store the machine or fuel container inside where there is an open flame, spark or pilot light as on a water heater, space heater, furnace, clothes dryer or other gas appliances.
- m. Allow a machine to cool at least 5 minutes before storing.

GENERAL SERVICE:

1. Never run an engine indoors or in a poorly ventilated area. Engine exhaust contains carbon monoxide, an odorless, and deadly gas.
2. Before cleaning, repairing, or inspecting, make certain the blade(s) and all moving parts have stopped. Disconnect the spark plug wire and ground against the engine to prevent unintended starting.
3. Periodically check to make sure the blades come to complete stop within approximately (5) five seconds after operating the blade disengagement control. If the blades do not stop within the this time frame, your unit should be serviced professionally by an authorized MTD Service Dealer.
4. Check brake operation frequently as it is subjected to wear during normal operation. Adjust and service as required.
5. Check the blade(s) and engine mounting bolts at frequent intervals for proper tightness. Also, visually inspect blade(s) for damage (e.g., excessive wear, bent, cracked). Replace the blade(s) with the original equipment manufacturer's (O.E.M.) blade(s) only, listed in this manual. “Use of parts which do not meet the original equipment specifications may lead to improper performance and compromise safety!”
6. Mower blades are sharp. Wrap the blade or wear gloves, and use extra caution when servicing them.
7. Keep all nuts, bolts, and screws tight to be sure the equipment is in safe working condition.

8. Never tamper with the safety interlock system or other safety devices. Check their proper operation regularly.
9. After striking a foreign object, stop the engine, disconnect the spark plug wire(s) and ground against the engine. Thoroughly inspect the machine for any damage. Repair the damage before starting and operating.
10. Never attempt to make adjustments or repairs to the machine while the engine is running.
11. Grass catcher components and the discharge cover are subject to wear and damage which could expose moving parts or allow objects to be thrown.

For safety protection, frequently check components and replace immediately with original equipment manufacturer's (O.E.M.) parts only, listed in this manual. "Use of parts which do not meet the original equipment specifications may lead to improper performance and compromise safety!"

12. Do not change the engine governor settings or over-speed the engine. The governor controls the maximum safe operating speed of the engine.
13. Maintain or replace safety and instruction labels, as necessary.
14. Observe proper disposal laws and regulations for gas, oil, etc. to protect the environment.



WARNING: YOUR RESPONSIBILITY Restrict the use of this power machine to persons who read, understand and follow the warnings and instructions in this manual and on the machine.

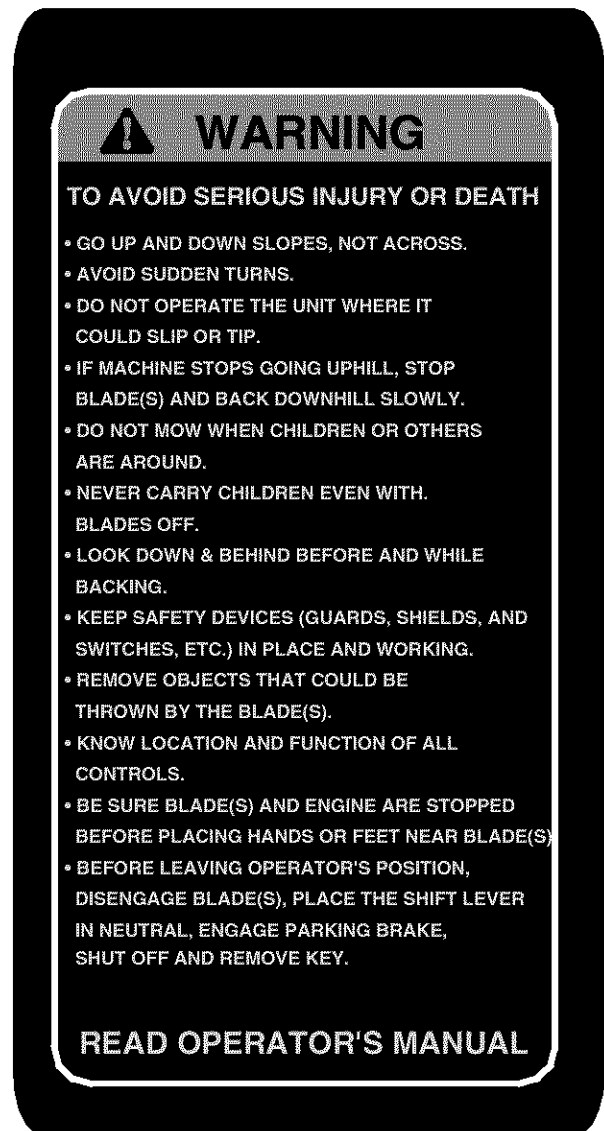
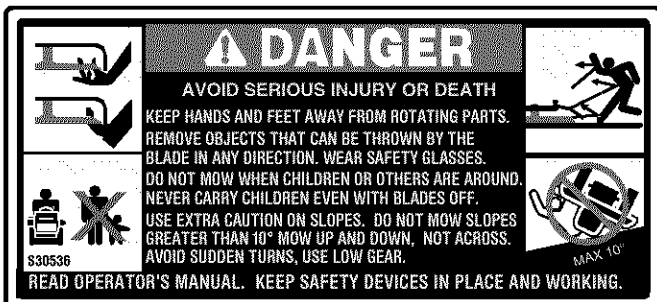

SECTION 2: SLOPE GAUGE

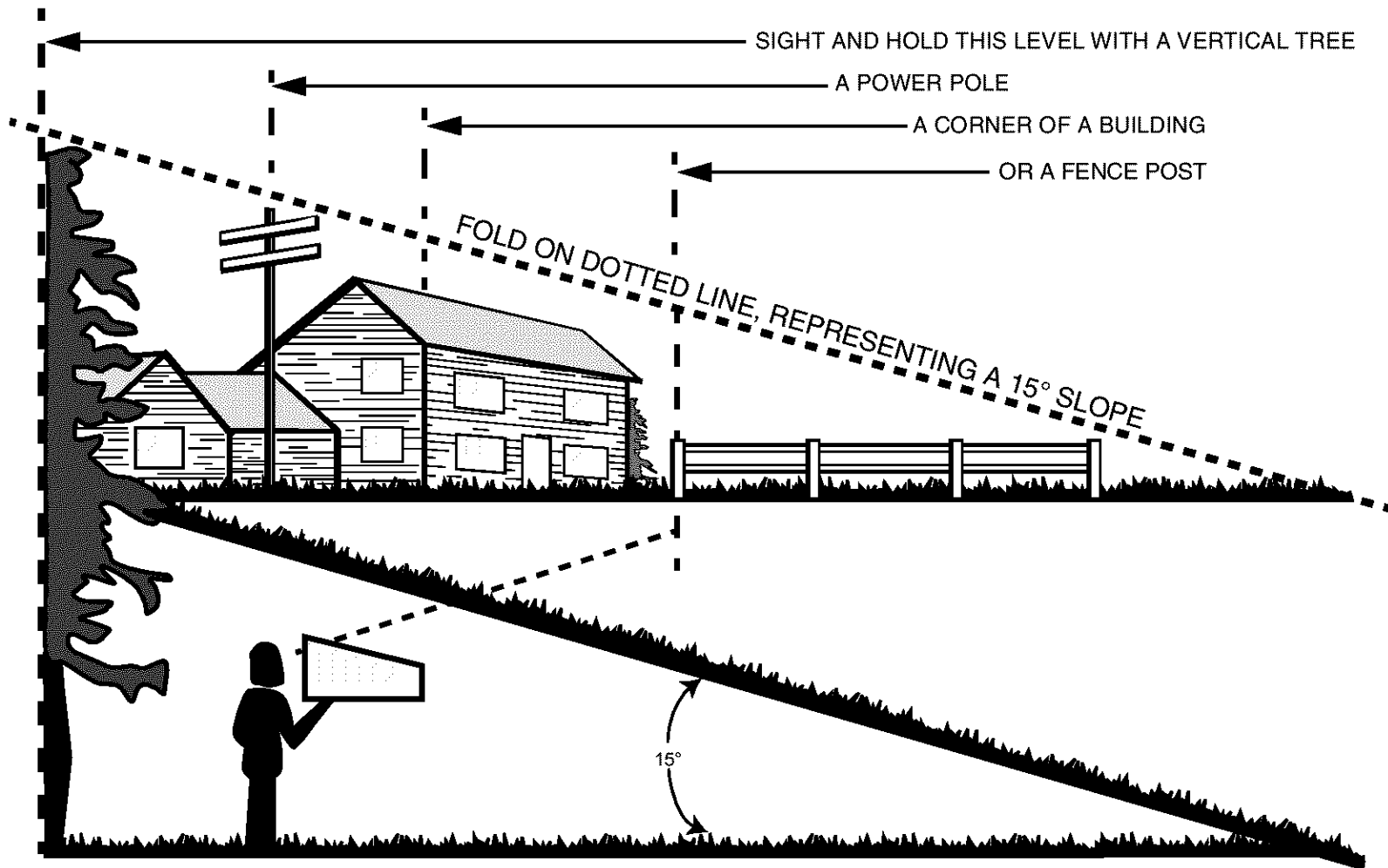

WARNING

Do not mow on inclines with a slope in excess of 15 degrees (a rise of approximately 2-1/2 feet every 10 feet). A riding mower could overturn and cause serious injury. If operating a walk-behind mower on such a slope, it is extremely difficult to maintain your footing and you could slip, resulting in serious injury. Operate RIDING mowers up and down slopes, never across the face of slopes.

SECTION 3: TRACTOR SET-UP

Attaching the Battery Cables

NOTE: The positive battery terminal is marked Pos. (+). The negative battery terminal is marked Neg. (-).

- The positive cable (heavy red wire) is secured to the positive battery terminal (+) with a hex bolt and hex nut at the factory. Make certain that the rubber boot covers the terminal to help protect it from corrosion.
- Remove the hex bolt and wing nut from the negative cable.
- Remove the black plastic cover, if present, from the negative battery terminal and attach the negative cable (heavy black wire) to the negative battery terminal (-) with the bolt and wing nut.
- Make certain the hold-down strap is in position over the battery, securing it in place. See Figure 1.

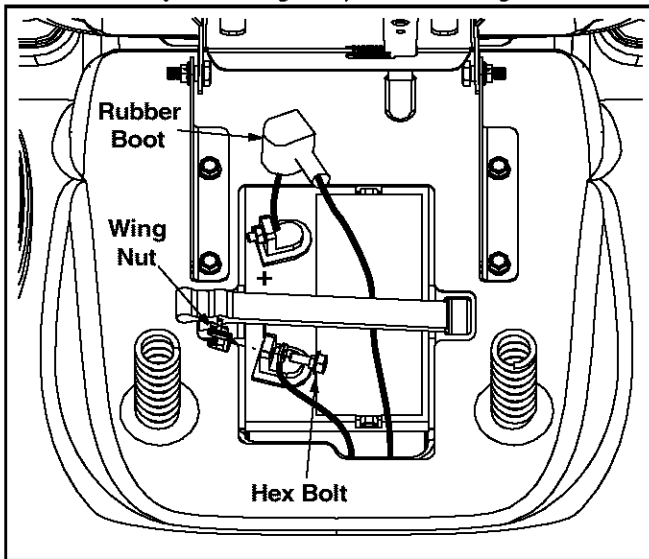

Figure 1

NOTE: If the battery is put into service after the date shown on top of battery, charge the battery as instructed on page 22 of this manual prior to operating the tractor.

Gas and Oil Fill-up

The gasoline tank is located under the hood and has a capacity of either two or three gallons. Do not overfill.



WARNING: Use extreme care when handling gasoline. Gasoline is extremely flammable and the vapors are explosive. Never fuel machine indoors or while the engine is hot or running. Extinguish cigarettes, cigars, pipes, and other sources of ignition.

Service the engine with gasoline and oil as instructed in the separate *Briggs & Stratton* Operator/Owner Manual (or *Kohler* engine's Owner's Manual) packed with your tractor. Read instructions carefully.

IMPORTANT: Your tractor is shipped with motor oil in the engine. However, you **MUST** check the oil level before operating. Be careful not to overfill.

Shipping Brace Removal



WARNING: Make sure the riding mower's engine is off, remove the ignition key, and set the parking brake before removing the shipping brace.

- Locate the shipping brace and accompanying warning tag found on the right side of the mower, between the discharge chute and the cutting deck. See Figure 2.

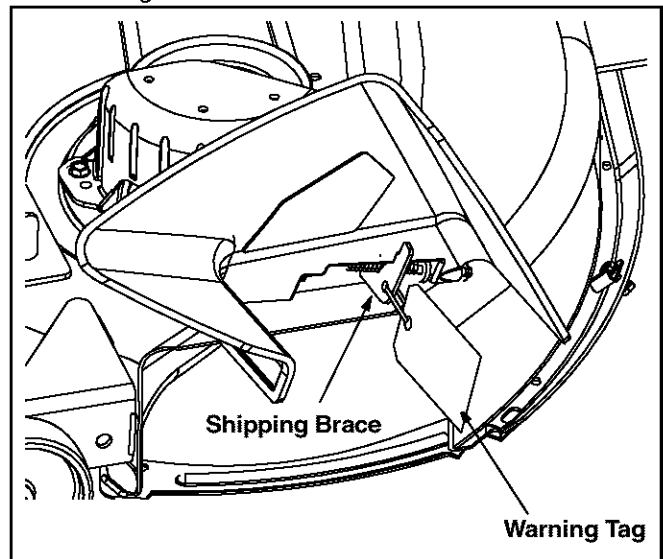

Figure 2

- While holding the discharge chute with your left hand, remove the shipping brace with your right hand by grasping it between your thumb and index finger and rotating it clockwise.



WARNING: The shipping brace, used for packaging purposes only, must be removed and discarded before operating your riding mower.



WARNING: The mowing deck is capable of throwing objects. Failure to operate the riding mower without the discharge cover in the proper operating position could result in serious personal injury and/or property damage.

SECTION 4: KNOW YOUR LAWN TRACTOR

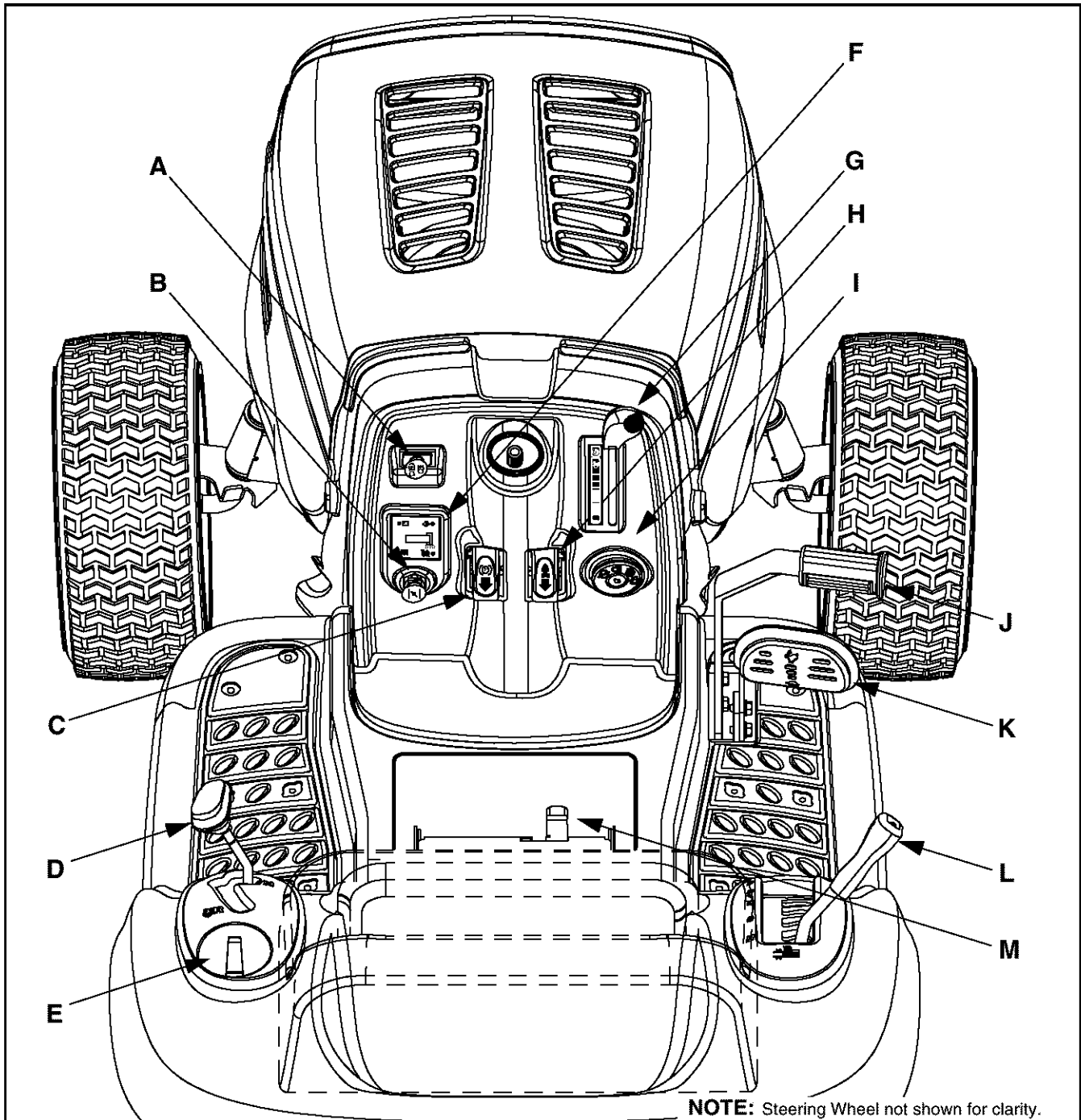

Figure 3

- | | |
|---|--------------------------------|
| A PTO (Power Take-off) Knob | H Cruise Control Button |
| B Choke Control | I Ignition Switch |
| C Parking Brake Button | J Brake Pedal |
| D Shift Lever | K Drive Pedal |
| E Cup Holder | L Deck Lift Lever |
| F Systems Indicator Monitor/Hour Meter | M Seat Adjustment Lever |
| G Throttle Control Lever | |

NOTE: Any reference in this manual to the RIGHT or LEFT side of the tractor is observed from operator's position.

Throttle Control Lever

The throttle control lever is located on the right side of the tractor's dash panel. This lever controls the speed of the engine. When set in a given position, the throttle will maintain a uniform engine speed. See Figure 4.

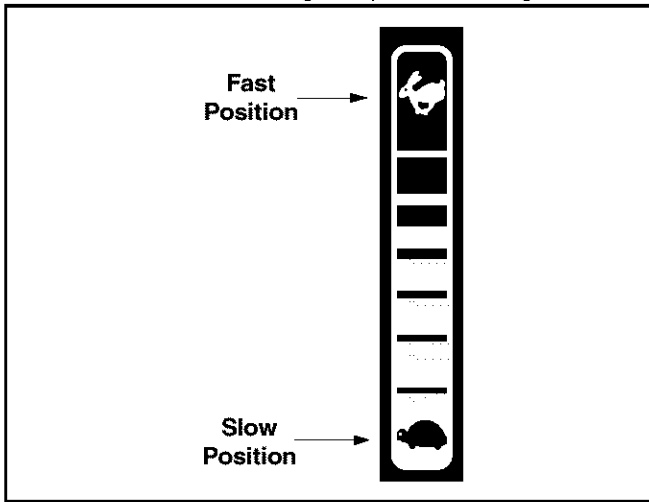
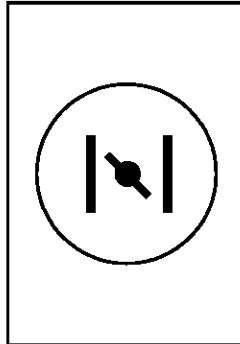

Figure 4

IMPORTANT: When operating the tractor with the cutting deck engaged, be certain that the throttle lever is **always** in the FAST (rabbit) position.

Choke Control

The choke control can be found on the left side of the dash panel and is activated by pulling the knob outward. Activating the choke control closes the choke plate on the carburetor and aids in starting the engine. Refer to **Starting The Engine** on page 13 of this manual for detailed starting instructions.



Brake Pedal

The brake pedal is located on the right front side of the tractor above the drive pedal along the running board. The brake pedal can be used for sudden stops or setting the parking brake.

NOTE: *The brake pedal must be fully depressed to activate the safety interlock switch when starting the tractor.*

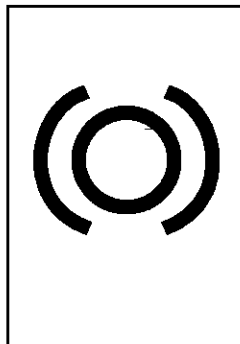

Ignition Switch



WARNING: Never leave a running machine unattended. Always disengage PTO, move shift lever into neutral position, set parking brake, stop engine and remove key to prevent unintended starting.

To start the engine, insert the key into the ignition switch and turn clockwise to the **START** position. Release the key into the **ON** position once engine has fired. See Figure 5.

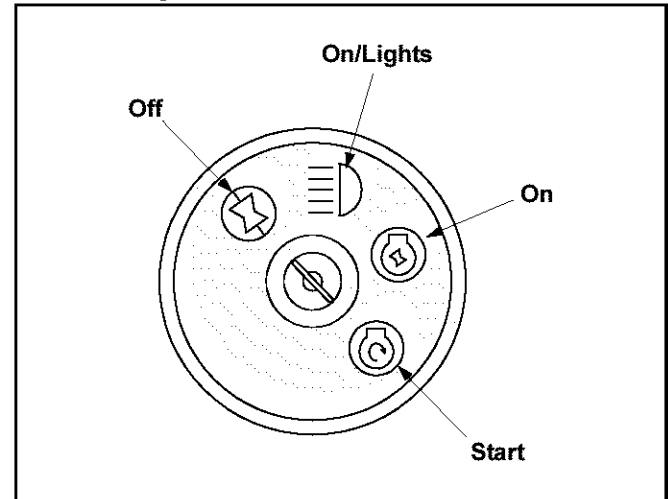

Figure 5

Refer to **Starting The Engine** on page 13 of this manual for detailed starting instructions

The ignition switch is also used to operate the tractor's headlights. Refer to **Operating The Headlights** on page 15 of this manual for detailed instructions.

Drive Pedal

The drive pedal is located below the brake pedal on the right front side of the tractor along the running board. Depress the drive pedal with your right foot when the tractor shift lever is in either **FORWARD** or **REVERSE** to cause the tractor to move.

Ground speed is also controlled with the drive pedal. The further down the pedal is depressed, the faster the tractor will travel. The pedal will return to its original position when it's not depressed.

IMPORTANT: Always set the parking brake when leaving the tractor unattended.

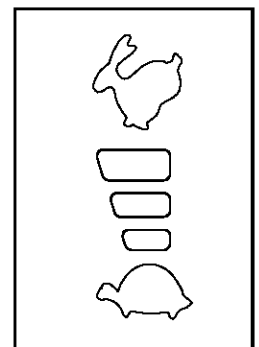

Systems Indicator Monitor / Hour Meter

Your tractor is equipped with four indicator lights and an hour meter located on the left side of the dash panel. See Figure 6.

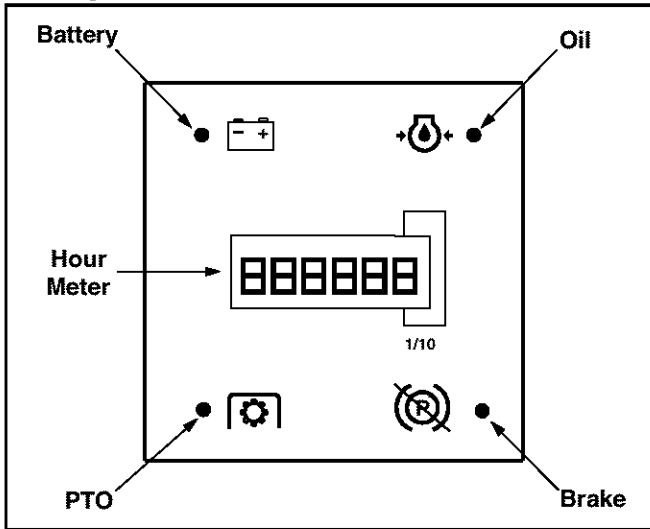

Figure 6

If the Brake light or PTO light illuminates when attempting to start the unit, proceed as follows:

- Brake** — Engage the parking brake.
- PTO** — Move the PTO knob into the disengaged (OFF) position.

It is normal for the Oil light and the Battery light to illuminate while the engine is **cranking**, but if either illuminates while the **engine is running**, proceed as follows:

- Oil**— Stop the tractor immediately and check the crankcase oil level as instructed in the *Briggs & Stratton Operator/Owner Manual* (or *Kohler engine's Owner's Manual*) included. Add oil as required.
- Battery**— If this light illuminate's while the engine is running, it indicates that the battery is in need of a charge OR that the engine's charging system is not generating sufficient amperage. Refer to **Battery** on page 22 of this manual for the proper battery charging procedure or have the engine's charging system checked by an authorized *Briggs & Stratton* or *Kohler* engines dealer.

The hour meter operates whenever the engine is running and records the actual hours of tractor operation.

Cup Holder

The tractor's cup holder is located on the fender to the left of the seat, just to the rear of the parking brake lever.

Electric PTO (Power Take-off) Knob

To engage the power to the cutting deck or other (separately available) attachments, pull outward on the PTO knob. Push the PTO knob inward to disengage the power to the cutting deck.

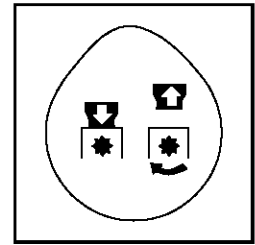

NOTE: The PTO knob **must** be in the disengaged (OFF) position when starting the engine, when traveling in reverse and if the operator leaves the seat.

Shift Lever

The shift lever is located on the left side of the fender and has three positions, FORWARD, NEUTRAL and REVERSE. The brake pedal must be depressed and the tractor must not be in motion when the moving shift lever. See Figure 7.

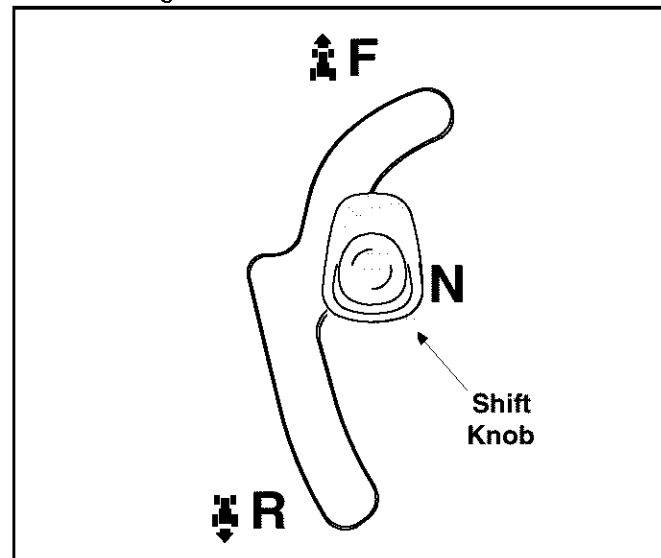

Figure 7

IMPORTANT: Never force the shift lever. Doing so may result in serious damage to the tractor's transmission.

Seat Adjustment Lever

To adjust the seat forward or backward, slide the seat adjustment lever to the left and reposition the seat to the desired position. Once a comfortable position is found, release the seat adjustment lever to lock the seat in place. Refer to **Seat Adjustment** on page 17 of this manual for more detailed instructions.

Deck Lift Lever

Found on your tractor's right fender, the deck lift lever is used to change the height of the cutting deck. To use, move the lever to the left, then place in the notch best suited for your application.

Parking Brake Button

To set the parking brake, fully depress the brake pedal and push the parking brake button in. Hold the button in while taking your foot off the brake pedal. Both the parking button and the brake pedal will then stay depressed. To release the parking brake, depress the brake pedal slightly. The parking brake button will then return to its original position.

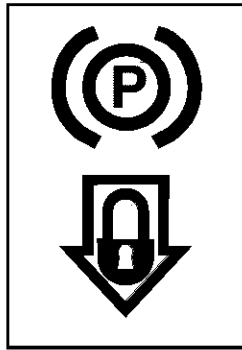

NOTE: The parking brake must be set if the operator leaves the seat with the engine running or the engine will automatically shut off.

IMPORTANT: Always set the parking brake when leaving the tractor unattended.

Cruise Control Button

The cruise control button is located on the tractor dash panel to the left of the ignition switch. Push the cruise control button while traveling forward at a desired speed. While holding the button in, release pressure from the drive pedal. This will engage the cruise control and allow the tractor to remain at that speed without applying pressure to the drive pedal. Depress the brake pedal or the drive pedal to deactivate cruise control. Refer to **SECTION 5: OPERATING YOUR LAWN TRACTOR** in this manual for detailed instructions regarding the cruise control feature.

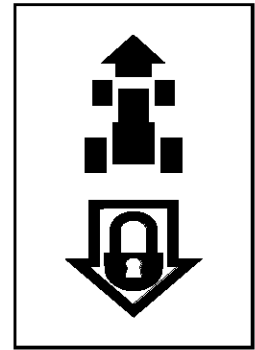

NOTE: Cruise control can not be engaged at the tractor's fastest ground speed. If the operator should attempt to do so, the tractor will automatically decelerate to the fastest optimal mowing ground speed.

SECTION 5: OPERATING YOUR LAWN TRACTOR



WARNING: Read, understand, and follow all instructions and warnings on the machine and in this manual before operating.

Safety Interlock Switches

This tractor is equipped with a safety interlock system for the protection of the operator. If the interlock system should ever malfunction, do not operate the tractor. Contact an authorized *MTD* service dealer. The safety interlock system prevents the engine from cranking or starting unless the parking brake is engaged, and the PTO knob is in the disengaged (OFF) position.

- The engine will automatically shut off if the operator leaves the seat before engaging the parking brake.
- The engine will automatically shut off if the operator leaves the tractor's seat with the PTO knob in the engaged (ON) position, regardless of whether the parking brake is engaged.
- The electric PTO clutch will automatically shut off if the PTO knob is moved into the engaged (ON) position with the shift lever in position for reverse travel.



Do not operate the tractor if the interlock system is malfunctioning. This system was designed for your safety and protection.



WARNING

AVOID SERIOUS INJURY OR DEATH

- GO UP AND DOWN SLOPES, NOT ACROSS.
- AVOID SUDDEN TURNS.
- DO NOT OPERATE THE UNIT WHERE IT COULD SLIP OR TIP.
- IF MACHINE STOPS GOING UPHILL, STOP BLADE(S) AND BACK DOWNHILL SLOWLY.
- DO NOT MOW WHEN CHILDREN OR OTHERS ARE AROUND.
- NEVER CARRY CHILDREN, EVEN WITH BLADES OFF.
- LOOK DOWN AND BEHIND BEFORE AND WHILE BACKING.
- KEEP SAFETY DEVICES (GUARDS, SHIELDS, AND SWITCHES) IN PLACE AND WORKING.
- REMOVE OBJECTS THAT COULD BE THROWN BY THE BLADE(S).
- KNOW LOCATION AND FUNCTION OF ALL CONTROLS.
- BE SURE BLADE(S) AND ENGINE ARE STOPPED BEFORE PLACING HANDS OR FEET NEAR BLADE(S).
- BEFORE LEAVING OPERATOR'S POSITION, DISENGAGE BLADE(S), PLACE THE SHIFT LEVER IN NEUTRAL, ENGAGE BRAKE LOCK, SHUT ENGINE OFF AND REMOVE KEY.

READ OPERATOR'S MANUAL

Setting the Cutting Height

Select the height position of the cutting deck by placing the deck lift lever in any of the six different cutting height notches on the right side of the fender. Then adjust the deck wheels so that they are between ¼-inch and ½-inch above the ground when the tractor is on a smooth, flat surface such as a driveway.



WARNING: Keep hands and feet away from the discharge opening of the cutting deck.

NOTE: *The deck wheels are an anti-scalp feature of the deck and are not designed to support the weight of the cutting deck.*

Refer to **Leveling the Deck** on page 16 of this manual for more detailed instructions regarding various deck adjustments.

Starting the Engine



WARNING: Do not operate the tractor if the interlock system is malfunctioning. This system was designed for your safety and protection.

NOTE: *Refer to the **TRACTOR SET-UP** on page 8 of this manual for Gasoline and Oil fill-up instructions.*

- Insert the tractor key into the ignition switch.
- Place the PTO knob in the disengaged (OFF) position.
- Engage the tractor's parking brake.
- Place the throttle control in the FAST (rabbit) position.
- Pull the choke control outward.
- Turn the ignition key clockwise to the START position. After the engine starts, release the key. It will return to the ON position.

IMPORTANT: Do NOT hold the key in the START position for longer than ten seconds at a time. Doing so may cause damage to your engine's electric starter.

- After the engine starts, deactivate the choke control and place the throttle control in the FAST position.

NOTE: *Do NOT leave the choke control on while operating the tractor. Doing so will result in a "rich" fuel mixture and cause the engine to run poorly.*

Stopping the Engine



WARNING: If you strike a foreign object, stop the engine, disconnect the spark plug wire(s) and ground against the engine. Thoroughly inspect the machine for any damage. Repair the damage before restarting and operating

- If the blades are engaged, place the PTO knob in the disengaged (OFF) position.
- Turn the ignition key counterclockwise to the OFF position.
- Remove the key from the ignition switch to prevent unintended starting.

Driving The Tractor



WARNING: Avoid sudden starts, excessive speed and sudden stops.



WARNING: Do not leave the seat of the tractor without first placing the PTO knob in the disengaged (OFF) position, depressing the brake pedal and engaging the parking brake. If leaving the tractor unattended, also turn the ignition key off and remove the key.

- Depress the brake pedal to release the parking brake and let the pedal up. Move the throttle lever into the FAST (rabbit) position.

IMPORTANT: Do NOT use the shift lever to change the direction of travel when the tractor is in motion. Always use the brake pedal to bring the tractor to a complete stop before shifting.

- To move forward, place the shift lever in the FORWARD position, then slowly depress the drive pedal until the desired speed is achieved.
- To move in reverse, place the shift lever in the REVERSE position, check that the area behind is clear then slowly depress the drive pedal.

Engaging the Parking Brake

To engage the parking brake:

- Fully depress the brake pedal and hold it there while gently pushing the parking brake button inward.
- Hold the parking brake button in while removing your foot from the brake pedal.
- Once engaged, the parking brake button and the brake pedal will lock in the "down" position.

To disengage the parking brake:

- Slightly depress the brake pedal.

NOTE: *The parking brake must be engaged if the operator leaves the seat with the engine running or the engine will automatically shut off.*

Driving On Slopes

Refer to the **SLOPE GAUGE** on page 7 to help determine slopes where you may operate the tractor safely.



WARNING: Do not mow on inclines with a slope in excess of 15 degrees (a rise of approximately 2-1/2 feet every 10 feet). The tractor could overturn and cause serious injury.

- Mow up and down slopes, NEVER across.
- Exercise extreme caution when changing direction on slopes.

- Watch for holes, ruts, bumps, rocks, or other hidden objects. Uneven terrain could overturn the machine. Tall grass can hide obstacles.
- Avoid turns when driving on a slope. If a turn must be made, turn down the slope. Turning up a slope greatly increases the chance of a roll over.
- Avoid stopping when driving up a slope. If it is necessary to stop while driving up a slope, start up smoothly and carefully to reduce the possibility of flipping the tractor over backward.

Setting The Cruise Control

NOTE: *The cruise control feature should only be utilized while traveling in the forward direction.*

- Place the shift lever in the FORWARD position, then slowly depress the drive pedal until the desired speed is achieved.
- Lightly depress the cruise control button.
- While continuing to hold the cruise button in, lift your foot from the drive pedal (you should feel the cruise latch engage).
- Once engaged, the cruise control button and the drive pedal will lock in the “down” position, and the tractor will maintain the same forward speed.

NOTE: *Cruise control can not be engaged at the tractor's fastest ground speed. If the operator should attempt to do so, the tractor will automatically decelerate to the fastest optimal mowing ground speed.*

Disengage the cruise control using one of the following methods:

- Depress the brake pedal to disengage the cruise control and stop the tractor.
- Lightly depress the drive pedal.

To change to the reverse direction when operating with cruise control, depress the brake pedal to disengage the cruise control and bring the tractor to a complete stop. Then place the shift lever in the REVERSE position and depress the drive pedal.

Using the Deck Lift Lever

To raise the cutting deck, move the deck lift lever to the left, then place it in the notch best suited for your application. Refer to **Setting The Cutting Height** earlier in this section.

Engaging the PTO

Engaging the PTO transfers power to the cutting deck or other (separately available) attachments. To engage the PTO, proceed as follows:

- Move the throttle control lever to the FAST (rabbit) position.
- Pull the PTO knob outward into the engaged (ON) position. See Figure 8.

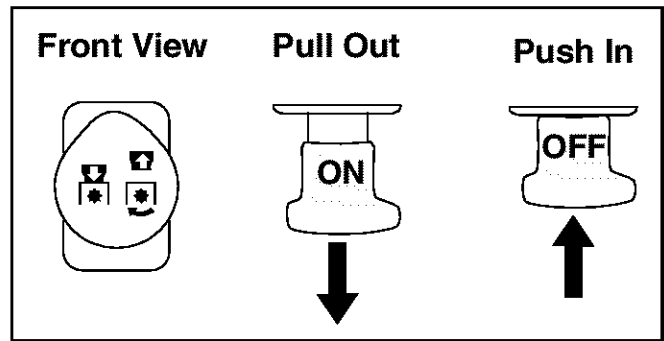

Figure 8

- Keep the throttle lever in the FAST (rabbit) position for the most efficient use of the cutting deck or other (separately available) attachments

IMPORTANT: The electric PTO clutch will automatically shut off if the PTO is engaged with the shift lever in position for reverse travel. Refer to **Safety Interlock Switches** on page 12.

Mowing



WARNING: To help avoid blade contact or a thrown object injury, keep bystanders, helpers, children and pets at least 75 feet from the machine while it is in operation. Stop machine if anyone enters the area.

This tractor is equipped with one of MTD's high quality cutting decks. The following information will be helpful when using the cutting deck with your tractor.



WARNING: Plan your mowing pattern to avoid discharge of materials toward roads, sidewalks, bystanders and the like. Also, avoid discharging material against a wall or obstruction which may cause discharged material to ricochet back toward the operator.

- Do not mow at high ground speed, especially if a mulch kit or grass collector is installed.
- For best results it is recommended that the first two laps be cut with the discharge thrown towards the center. After the first two laps, reverse the direction to throw the discharge to the outside for the balance of cutting. This will give a better appearance to the lawn.
- Do not cut the grass too short. Short grass invites weed growth and yellows quickly in dry weather.
- Mowing should always be done with the engine at full throttle.
- Under heavier conditions it may be necessary to go back over the cut area a second time to get a clean cut.
- Do NOT attempt to mow heavy brush and weeds and extremely tall grass. Your tractor is designed to mow lawns, NOT clear brush.

- Keep the blades sharp and replace the blades when worn. Refer to **Cutting Blades** on page 21 of this manual for proper blade sharpening instructions.

Mulching

Model J609H & Y609H tractors come equipped with a mulch kit packed separately within the tractor's crate. Once installed, the kit incorporates special blades, already standard on your tractor, in a process of recirculating grass clippings repeatedly beneath the cutting deck. The ultra-fine clippings are then forced back into the lawn where they act as a natural fertilizer. Observe the instructions included with the mulch kit for the best results when mulching.

Operating The Headlights

To turn the tractor's headlights on:

- Start the engine following the instructions earlier in this section.
- Turn the key one notch counterclockwise into the On/Lights position of the ignition switch. Refer to Figure 5.

To turn the tractor's headlights off:

- Turn the key either into the On position (to leave the engine running) or the Off position (to shut the engine off). Refer to Figure 5.

NOTE: Never move the key into the Start position while the engine is running. Doing so may cause damage to your engine's electric starter.

SECTION 6: MAKING ADJUSTMENTS



WARNING: Never attempt to make any adjustments while the engine is running, except where specified in the operator's manual.



WARNING: Disconnect the spark plug wire(s) and ground against the engine before performing any adjustments, repairs or maintenance.

Parking Brake Adjustment



WARNING: Never attempt to adjust the brakes while the engine is running. Always disengage PTO, move shift lever into neutral position, stop engine and remove key to prevent unintended starting.

If the tractor does not come to a complete stop when the brake pedal is completely depressed, or if the tractor's rear wheels can roll with the parking brake applied, the brake is in need of adjustment. The brake disc can be found on the right side of the transmission in the rear of the tractor. Adjust if necessary as follows:

- Looking at the transmission from the right side of the tractor, locate the compression spring and brake disc. See Figure 9.
- Loosen, but do NOT remove, the hex nut found on the right side of the brake assembly. See Figure 9.
- Using a feeler gauge, set the gap between the brake disc and the brake puck at .011".
- Re-tighten the hex nut loosened earlier.

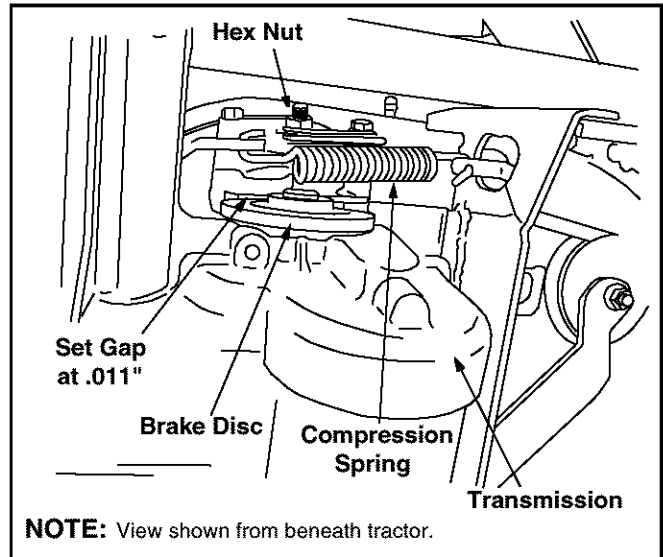

Figure 9

Seat Adjustment



WARNING: Before operating this machine, make sure the seat is engaged in the seat stop, stand behind the machine and pull back on seat until fully engaged into stop.

To adjust the position of the seat, move the seat adjustment lever to the left and slide the seat forward or rearward. Make sure seat is locked into position before operating the tractor.

Steering Adjustment

If the tractor turns tighter in one direction than the other, or if the ball joints are being replaced due to damage or wear, the steering drag links may need to be adjusted.

Adjust the drag links so that equal lengths are threaded into the ball joint on the left side and the ball joint on the right side:

- Loosen the jam nut found on the drag link at the rear of the ball joint. See Figure 10.

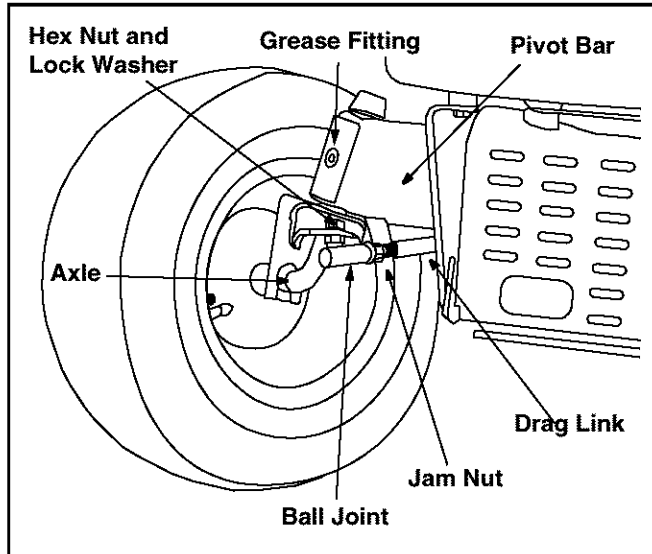

Figure 10

- Remove the hex nut and lock washer on the top of ball joint. See Figure 10.
- Thread the ball joint toward the jam nut to shorten the drag link. Thread the ball joint away from the jam nut to lengthen the drag link.
- Replace hex nut and lock washer and retighten the jam nut after proper adjustment is achieved.

NOTE: Threading the ball joints too far onto the drag links will cause the front tires to "toe-in" too far. Proper toe-in is between 1/16" and 5/16".

Front tire toe-in can be measured as follows:

- Place the steering wheel in position for straight ahead travel.
- In front of the axle, measure the distance horizontally from the inside of the left rim to the inside of the right rim. Note the distance.
- Behind the axle, measure the distance horizontally from the inside of the left rim to the inside of the right rim. Note the distance.
- The measurement taken in front of the axle should be between 1/16" and 5/16" less than the measurement taken behind the axle. Adjust if necessary.

Leveling the Deck

NOTE: Check the tractor's tire pressure before performing any deck leveling adjustments. Refer to **Tires** on page 21 for information regarding tire pressure.

Front To Rear

The front of the cutting deck is supported by a stabilizer bar that can be adjusted to level the deck from front to rear. The front of the deck should be between 1/4-inch and 3/8-inch lower than the rear of the deck. Adjust if necessary as follows:

- With the tractor parked on a firm, level surface, place the deck lift lever in the top notch (highest position) and rotate the blade nearest the discharge chute so that it is parallel with the tractor.
- Measure the distance from the front of the blade tip to the ground and the rear of the blade tip to the ground.
- The first measurement taken should be between 1/4" and 3/8" less than the second measurement. Determine the approximate distance necessary for proper adjustment and proceed, if necessary, to the next step.
- Loosen the two jam nuts on the rear side of the deck stabilizer bracket. See Figure 11.
- Locate the two lock nuts on the opposite side of the stabilizer bracket. See Figure 11. Tighten the lock nuts to raise the front of the deck; loosen the lock nuts to lower the front of the deck.
- Retighten the two jam nuts loosened earlier when proper adjustment is achieved.

Side to Side

If the cutting deck appears to be mowing unevenly, a side to side adjustment can be performed. Adjust if necessary as follows:

- With the tractor parked on a firm, level surface, place the deck lift lever in the top notch (highest position) and rotate both blades so that they are perpendicular with the tractor.
- Measure the distance from the outside of the left blade tip to the ground and the distance from the outside of the right blade tip to the ground. Both measurements taken should be equal. If they're not, proceed to the next step.
- Loosen, but do NOT remove, the hex cap screw on the left deck hanger bracket. See Figure 11B.
- Balance the deck by using a wrench to turn the adjustment gear (found immediately behind the hex cap screw just loosened) clockwise/up or counterclockwise/down.
- The deck is properly balanced when both blade tip measurements taken earlier are equal.
- Retighten the hex cap screw on the left deck hanger bracket when proper adjustment is achieved.

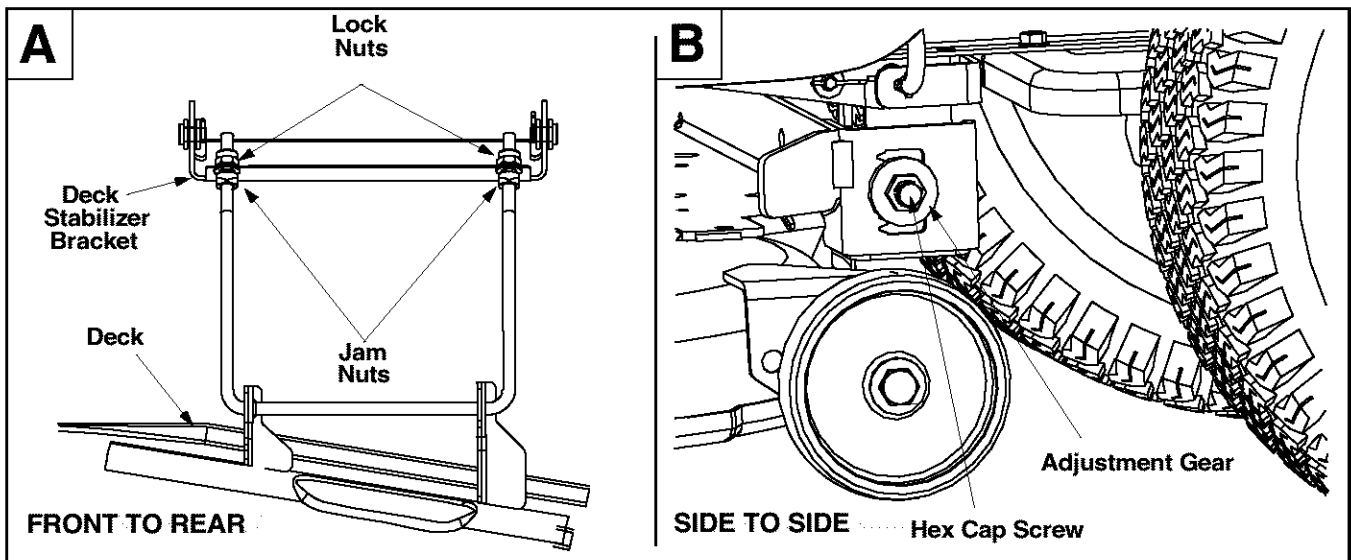

Figure 11

SECTION 7: MAINTAINING YOUR LAWN TRACTOR



WARNING: Before performing any maintenance or repairs, disengage PTO, move shift lever into neutral position, set parking brake, stop engine and remove key to prevent unintended starting.

Engine

Refer to the *Briggs & Stratton Operator/Owner Manual* (or *Kohler engine's Owner's Manual*) for engine maintenance instructions.

Check **engine oil level** before each use as instructed in the *Briggs & Stratton Operator/Owner Manual* (or *Kohler engine's Owner's Manual*) packed with your unit. **Follow the instructions carefully.**

Changing Engine Oil

NOTE: Depending on the engine model found on your tractor, it may be necessary to remove the tractor's side panel in order to replace the oil filter (if so equipped).

- Unscrew oil fill cap and remove dipstick from the oil fill tube. See Figure 12.
- Pop open the protective cap on the end of the oil drain valve to expose the drain port. See Figure 12.
- Push the oil drain hose (packed with this manual) onto the oil drain port. Route the opposite end of the hose into an appropriate oil collection container with a capacity great enough to collect the used oil (approximately 64 oz.).
- Push the oil drain valve in slightly, then rotate counterclockwise and pull outward to begin draining oil. See Figure 12.

- Service the **oil filter** (if so equipped) as instructed in the separate *Briggs & Stratton Operator/Owner Manual* (or *Kohler engine's Owner's Manual*) packed with your unit.

Perform the above steps in the opposite order after oil has finished draining.

- Refill the engine with new motor oil.

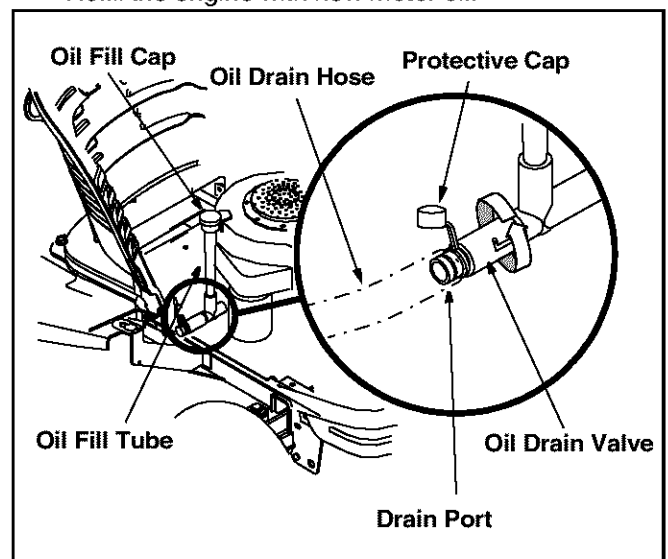

Figure 12

IMPORTANT: Refer to the *Briggs & Stratton Operator/Owner Manual* (or *Kohler engine's Owner's Manual*) packed with your unit for information regarding the quantity and proper weight of motor oil.

Air Cleaner

Service the pre-cleaner, if so equipped, and cartridge/air cleaner element as instructed in the *Briggs & Stratton Operator/Owner Manual* (or *Kohler engine's Owner's Manual*) packed with your unit.

Spark Plugs

The spark plugs should be cleaned and the gap reset once a season. Spark plug replacement is recommended at the start of each mowing season. Refer to the *Briggs & Stratton Operator/Owner Manual* (or *Kohler engine's Owner's Manual*) for correct plug type and gap specifications.

Cleaning the Engine And Deck

Any fuel or oil spilled on the machine should be wiped off promptly. Do NOT allow debris to accumulate around the cooling fins of the engine or on any other part of the machine, especially the belts, pulleys and other moving parts. Clean the underside of the deck with a wisk broom, scraper or forced air after each mowing.

IMPORTANT: The use of a pressure washer or garden hose to clean your tractor is NOT recommended. It may cause damage to electrical components, spindles, pulleys, bearings or the engine. The use of water will result in a shortened life of the tractor and reduce its serviceability.

Lubrication



WARNING: Before lubricating, repairing, or inspecting, always disengage PTO, move shift lever into neutral position, set parking brake, stop engine and remove key to prevent unintended starting.

Engine

Lubricate the engine with motor oil as instructed in the *Briggs & Stratton Operator/Owner Manual* (or *Kohler engine's Owner's Manual*) packed with your unit.

Pivot Points & Linkage

Lubricate all the pivot points on the drive system, parking brake and lift linkage at least once a season with light oil.

Rear Wheels

The rear wheels should be removed from the axles once a season. Lubricate the axles and the rims well with an all-purpose grease before re-installing them.

Front Wheels

Each end of the tractor's front pivot bar is equipped with a grease fitting. Lubricate with a grease gun after every 25 hours of tractor operation.

SECTION 8: SERVICE



WARNING: Before servicing, repairing, or inspecting, always disengage PTO, move shift lever into neutral position, set parking brake, stop engine and remove key to prevent unintended starting.

Cutting Deck Removal

To remove the cutting deck, proceed as follows:

- Place the PTO knob in the disengaged (OFF) position and engage the parking brake.
- Lower the deck by moving the deck lift lever into the bottom notch on the right fender.
- Remove the PTO belt from around the electric PTO clutch. Refer to Figure 14.
- Looking at the cutting deck from the left side of the tractor, locate the deck support pin on the rear left side of the deck.
- Pull the deck support pin outward to release the deck from the deck lift arm. See Figure 13.
- Rotate the pin slightly toward the rear of the tractor and release the pin into the hole provided.
- Repeat the above steps on the tractor's right side.

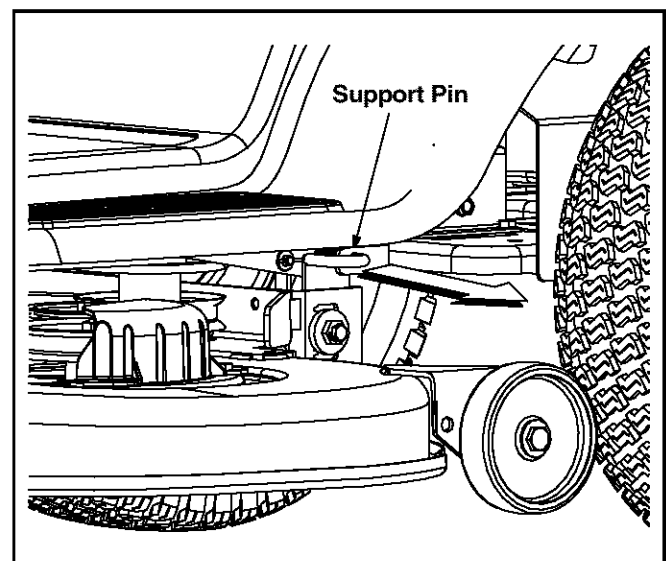

Figure 13

- Move the deck lift lever into the top notch on the right fender to raise the deck lift arms up and out of the way.

- Gently slide the cutting deck toward the front of the tractor allowing the hooks on the deck to release themselves from the deck stabilizer rod.
- Gently slide the cutting deck (from the right side) out from underneath the tractor.

Changing the Deck Belt(s)



WARNING: Be sure to shut the engine off, remove ignition key, disconnect the spark plug wire(s) and ground against the engine to prevent unintended starting before removing the belt(s).

All belts on your tractor are subject to wear and should be replaced if any signs of wear are present.

IMPORTANT: The V-belts found on your tractor are specially designed to engage and disengage safely. A substitute (non-OEM) V-belt can be dangerous by not disengaging completely. For a proper working machine, use factory approved belts.

To change or replace the deck belts on your tractor, proceed as follows:

- Lower the deck by moving the deck lift lever into the bottom notch on the right fender.
- Remove the belt guards by removing the self-tapping screws that fasten them to the deck.
- Grasp the PTO idler bracket and pivot it toward the discharge chute to relieve tension on the PTO belt.
- Remove the PTO belt from the electric PTO clutch and from around the PTO idler pulley.
- Grasp the deck idler pulley and pivot it toward the left side of the deck to relieve tension on the belt.
- Remove the belt from around all pulleys, including the deck idler pulley.
- Route the new belts as shown in Figure 14.
- Remount the belt guards removed earlier.

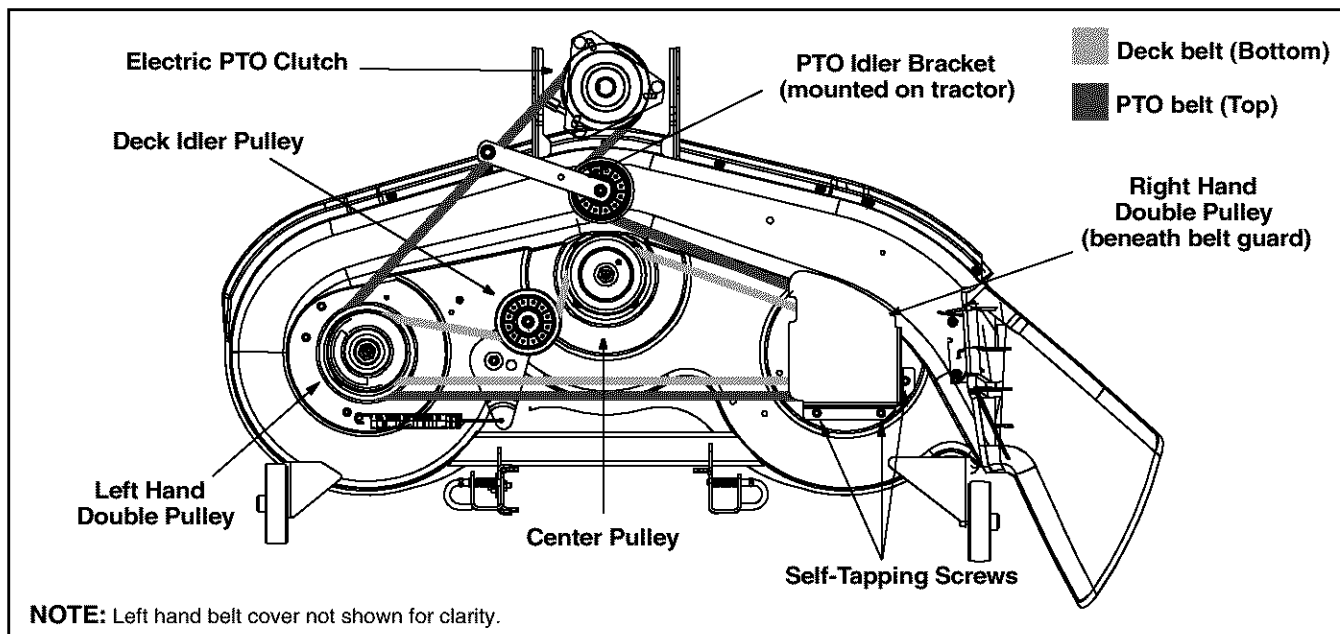

Figure 14

Changing the Transmission Drive Belt



WARNING: Be sure to shut the engine off, remove ignition key, disconnect the spark plug wire(s) and ground against the engine to prevent unintended starting before removing the belt(s)

All belts on your tractor are subject to wear and should be replaced if any signs of cracking, shredding or rotting are present.

IMPORTANT: The V-belts found on your tractor are specially designed to engage and disengage safely. A substitute (non-OEM) V-belt can be dangerous by not disengaging completely. For a proper working machine, use factory approved belts.

To change or replace the drive belt on your tractor, proceed as follows:

NOTE: It's recommended that both drive belts be replaced at the same time.

- Remove the cutting deck as instructed earlier in this section.

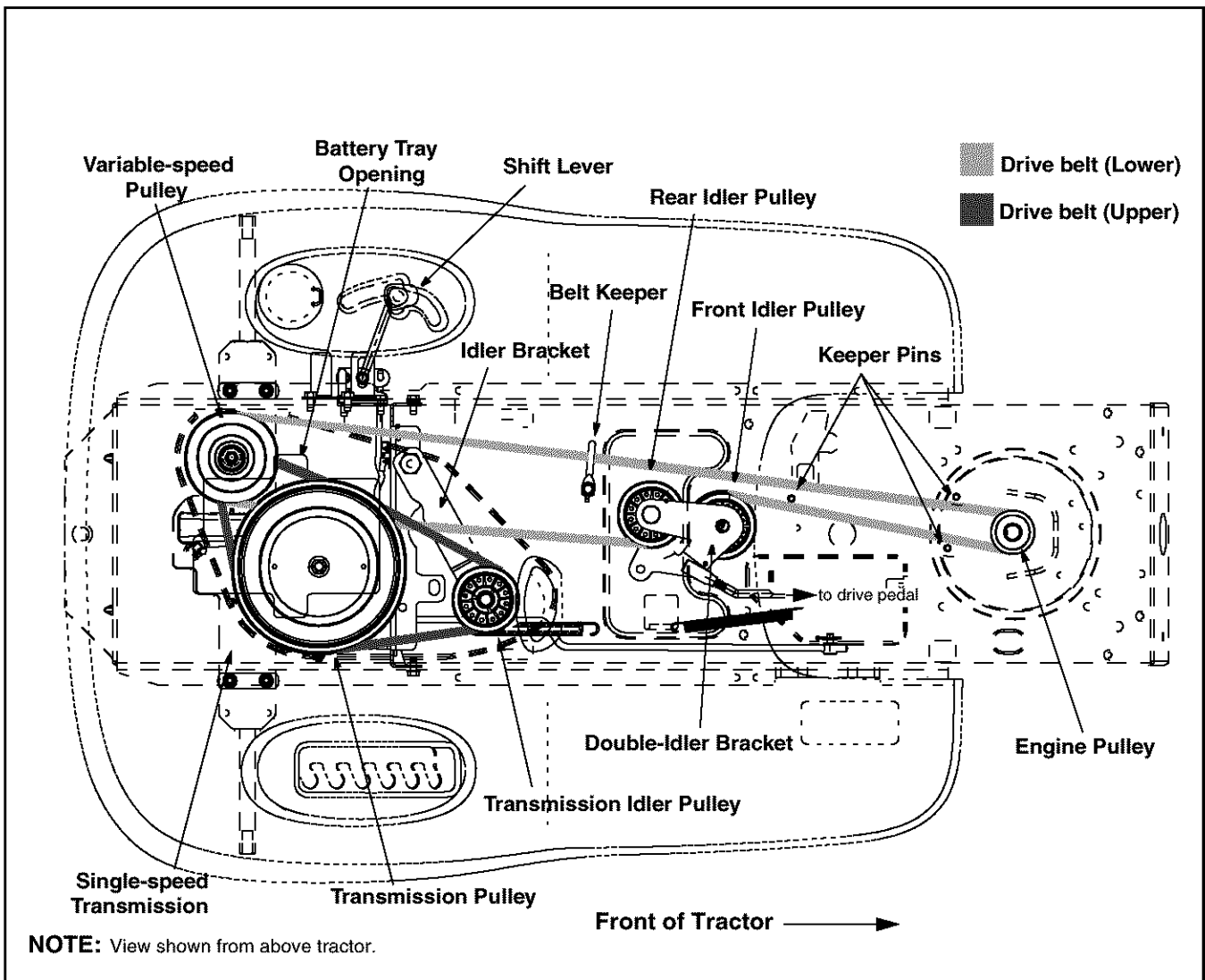

Figure 15

- After disconnecting the battery cables, remove the battery and battery tray from beneath the seat.

IMPORTANT: When removing the battery, disconnect the **NEGATIVE** (Black) wire from its terminal first, followed by the **POSITIVE** (Red) wire. Re-install in reverse order.

Upper Drive Belt

- Locate the transmission idler pulley on the upper drive belt by looking through the battery tray opening. See Figure 15.
- Grasp the bracket and pivot the transmission idler pulley toward the rear of the tractor to release tension on the upper drive belt.
- Remove the belt from around the transmission idler pulley.
- Remove the upper drive belt from around the transmission pulley and the variable-speed pulley.

NOTE: Slowly rotate the pulley counterclockwise to roll the belt off of it.

- Remove the upper drive belt by pulling it up through the battery tray opening.
- Reroute the new upper drive belt as shown in Figure 15.

Lower Drive Belt

NOTE: Proper removal of the lower drive belt requires the removal of several tractor components. Read through the following procedure prior to attempting it to determine if you feel you could successfully complete it. If you don't, see an authorized MTD Service Dealer to have the belt changed.

IMPORTANT: Note the routing of the lower drive belt around both the pulleys and the belt keepers **BEFORE** performing the following steps.

- Locate the variable-speed pulley through the battery tray opening. See Figure 15.
- Remove the variable-speed pulley by loosening the hex bolt that secures it to the transmission. Use a second wrench to hold the hex nut on the bottom side of the pulley.

- Slide the belt off of the variable-speed pulley as you lift the pulley up and out through the battery tray opening.
- Remove the rear idler pulley from the double-idler bracket while unrouting the belt from around both the rear and the front idler pulley. Refer to Figure 15.
- Remove the hex bolt from the center of the electric PTO clutch and gently lower it off of the engine crankshaft. Be careful not to lose any washers or which may be found on top of the PTO clutch.

IMPORTANT: When remounting the PTO clutch, torque the center hex bolt to between 38 foot-pounds and 50 foot-pounds.

- Remove the drive belt by feeding it from both ends toward the front idler pulley on the double-idler bracket. See Figure 15.
- Reassemble by following the above steps in reverse order.
- Reroute the new belt around the pulleys, belt keepers and keeper pins EXACTLY as the old one was routed. Refer to Figure 15.

The drive pedal is properly adjusted when the hole found in the double-idler bracket has approximately 1-3/8" of travel with ten pounds of pressure applied to the drive pedal. See Figure 16.

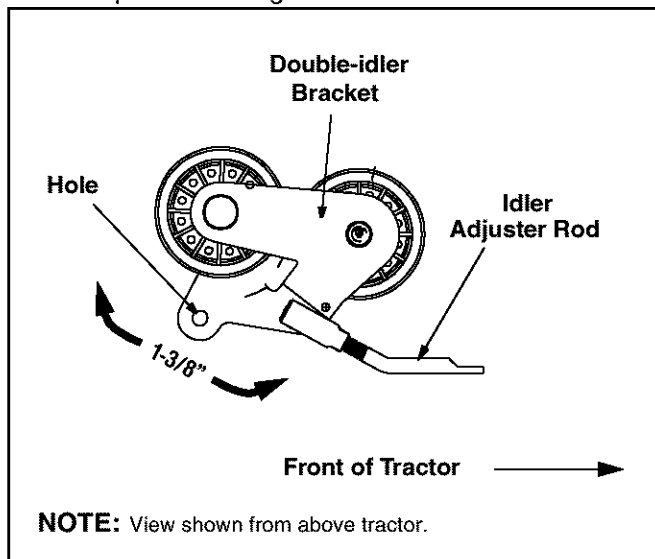

Figure 16

Adjust the drive pedal after replacing the drive belts on your tractor, if necessary, as follows:

- Locate the speed control assembly on the underside of the steering support bracket. See Figure 17•.
- Remove both hairpin clips from the pin which is fastened to the speed control assembly (be careful not to lose the small flat washers found on the pin). See Figure 17

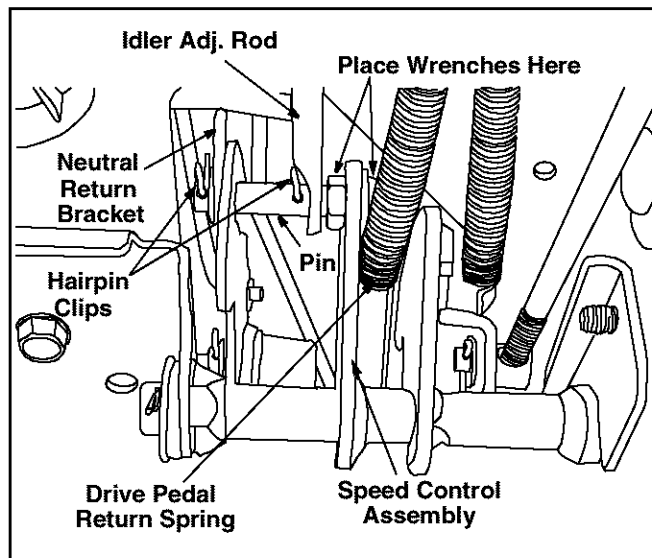

Figure 17

- Remove the drive pedal return spring.
- Using two 9/16" wrenches, remove the pin from the speed control assembly. See •Figure 17.
- Thread the idler adjustment rod inward or outward to lengthen or shorten the travel of the double-idler bracket until proper adjustment is achieved.
- Reassemble by following the above steps in reverse order.

Tires



WARNING: Never exceed the maximum inflation pressure shown on the sidewall of the tire.

The recommended operating tire pressure is approximately 10 psi for the rear tires and approximately 14 psi for the front tires. Refer to the tire sidewall for exact tire manufacturer's recommended or maximum psi. Do not overinflate. Uneven tire pressure could cause the cutting deck to mow unevenly.

Cutting Blades



WARNING: Be sure to shut the engine off, remove ignition key, disconnect the spark plug wire(s) and ground against the engine to prevent unintended starting before removing the cutting blade(s) for sharpening or replacement. Protect your hands by using heavy gloves or a rag to grasp the cutting blade.



WARNING: Periodically inspect the blade adapter and/or spindle for cracks or damage, especially if you strike a foreign object. Replace immediately if damaged.

The blades may be removed as follows.

- Remove the deck from beneath the tractor, (refer to **Cutting Deck Removal** on page 18) then gently flip the deck over to expose its underside.
- Place a block of wood between the center deck housing baffle and the cutting blade to act as a stabilizer. See Figure 18.

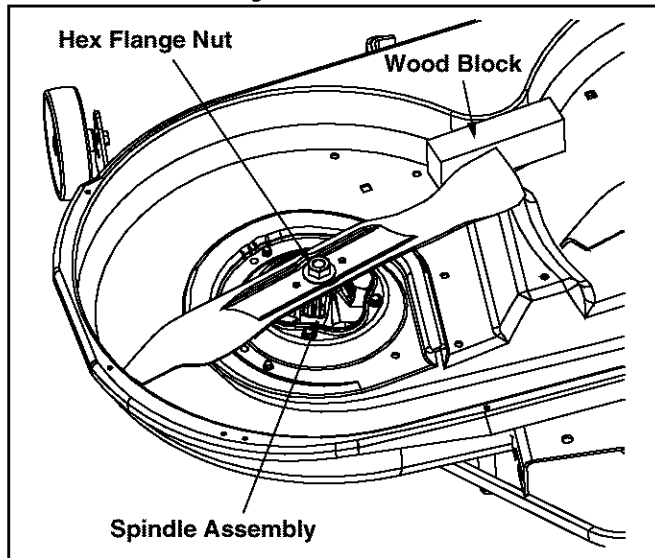

Figure 18

- Use a 15/16" wrench to remove the hex flange nut that secures the blade to the spindle assembly. See Figure 18.

To properly sharpen the cutting blades, remove equal amounts of metal from both ends of the blades along the cutting edges, parallel to the trailing edge, at a 25° to 30° angle. See Figure 19.

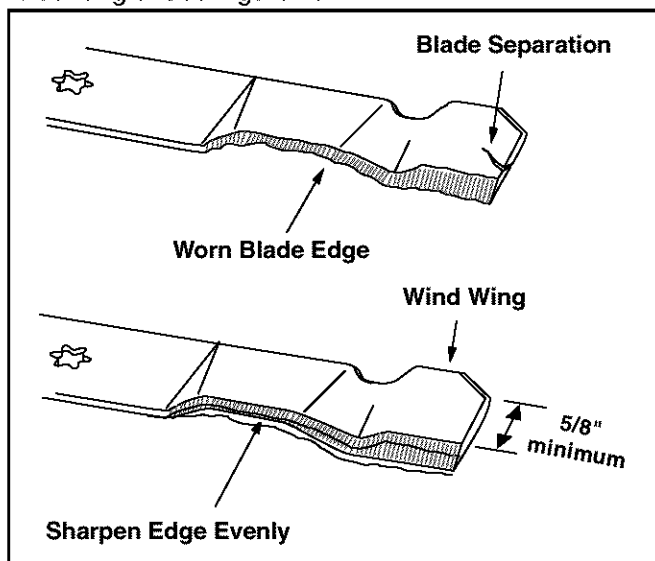

Figure 19

IMPORTANT: If the cutting edge of the blade has already been sharpened to within 5/8" of the wind wing radius, or if any metal separation is present, replace the blades with new ones. See Figure 19.

It is important that each cutting blade edge be ground equally to maintain proper blade balance. A poorly balanced blade will cause excessive vibration and may cause damage to the tractor and result in personal injury.

The blade can be tested by balancing it on a round shaft screwdriver. Grind metal from the heavy side until it balances evenly.

When replacing the blade, be sure to install the blade with the side of the blade marked "Bottom" (or with a part number stamped in it) facing the ground when the mower is in the operating position.

IMPORTANT: Use a torque wrench to tighten the blade spindle hex flange nut to between 70 foot-pounds and 90 foot-pounds.

Battery

The battery is sealed and is maintenance-free. Acid levels cannot be checked.

- Always keep the battery cables and terminals clean and free of corrosive build-up.
- After cleaning the battery and terminals, apply a light coat of petroleum jelly or grease to both terminals
- Always keep the rubber boot positioned over the positive terminal to prevent shorting.

IMPORTANT: If removing the battery for any reason, disconnect the NEGATIVE (Black) wire from it's terminal first, followed by the POSITIVE (Red) wire. When re-installing the battery, always connect the POSITIVE (Red) wire its terminal first, followed by the NEGATIVE (Black) wire. Be certain that the wires are connected to the correct terminals; reversing them could change the polarity and cause damage to your engine's alternating system.

Charging

If the unit has not been put into use for an extended period of time, charge the battery with an automotive-type 12-volt charger for a minimum of one hour at six amps.



WARNING: Batteries give off an explosive gas while charging. Charge battery in a well ventilated area and keep away from an open flame or pilot light as on a water heater, space heater, furnace, clothes dryer or other gas appliances.

Fuses

Two fuses are installed in your tractor's wiring harness to protect the tractor's electrical system from damage caused by excessive amperage.

If the electrical system does not function, or your tractor's engine will not crank, first check to be certain that the fuse has not blown.

One can be found under the hood mounted behind the top of the dash panel on the support bar. The other can be found under the seat mounted to the inside of the tractor frame next to the battery tray. Pull the fuse out and inspect it to determine if it is good or blown.

IMPORTANT: Always use a fuse with the same amperage capacity for replacement.

SECTION 9: OFF-SEASON STORAGE

Clean and lubricate the tractor as instructed in **Section 7: MAINTAINING YOUR LAWN TRACTOR** on page 17 of this manual before storing for an extended period.



WARNING: Drain fuel only into an approved container outdoors, away from an open flame. Allow engine to cool. Extinguish cigarettes, cigars, pipes, and other sources of ignition prior to draining fuel.

Follow the instructions in the **Service, Storage & Specifications** section of the *Briggs & Stratton* Operator/Owner Manual (or *Kohler* engines Manual) for proper engine care prior to storing your tractor.



WARNING: Never store the machine or fuel container indoors where there is an open flame, spark or pilot light such as on water heater, furnace, clothes dryer or other gas appliance.

SECTION 10: ATTACHMENTS & ACCESSORIES

The following attachments and accessories are compatible for **Lawn Tractor Model J609H & Y609H**. See the retailer from which you purchased your tractor, an authorized *MTD* Service Dealer or phone (800) 800-7310 for information regarding price and availability.

NOTE: *Lawn tractor models J609H and Y609H are NOT designed for use with any type of ground-engaging attachments (e.g. tiller or plow). Use of this type of equipment WILL void the tractor's warranty.*

| MODEL | DESCRIPTION |
|-------------|--|
| OEM-190-118 | 46-inch Deck Mulch Kit |
| OEM-190-602 | FastAttach™ Twin Bagger Grass Collector |
| OEM-190-603 | FastAttach™ Grille Guard (mounts on front of tractor) |
| OEM-190-604 | FastAttach™ Yard-Mate™ Storage Container/Toolbox (mounts on rear of tractor) |
| OEM-190-607 | FastAttach™ Deluxe Tractor Sunshade |
| OEM-190-822 | FastAttach™ 46-inch Front Dozer Blade |
| OEM-190-823 | FastAttach™ 42-inch Two-stage Snow Thrower |

SECTION 11: TROUBLESHOOTING

| Trouble | Possible Cause(s) | Corrective Action |
|------------------------------|--|--|
| Engine fails to start | PTO knob engaged. Parking brake not engaged. Spark plug wire(s) disconnected. Throttle control lever not in correct starting position. Choke not activated Fuel tank empty, or stale fuel. Blocked fuel line. Faulty spark plug. Engine flooded. | Place PTO knob in disengaged (OFF) position. Engage parking brake. Connect wire(s) to spark plug. Place throttle lever to FAST position. Pull out the CHOKE control (if so equipped). Fill tank with clean, fresh (less than 30 days old) gas. Clean fuel line or replace fuel filter, if so equipped. Clean, adjust gap or replace plug. Crank engine with throttle in FAST position. |
| Engine runs erratic | Unit running with CHOKE applied. Spark plug wire(s) loose. Blocked fuel line or stale fuel. Vent in gas cap plugged. Water or dirt in fuel system. Dirty air cleaner. | Push CHOKE control (if so equipped) in. Connect and tighten spark plug wire(s). Clean fuel line; fill tank with clean, fresh (less than 30 days old) gasoline. Replace fuel filter, if so equipped. Clear vent or replace cap if damaged. Drain fuel tank. Refill with clean, fresh (less than 30 days old) gasoline. Replace air cleaner cartridge/element or clean pre-cleaner, if so equipped. |
| Engine overheats | Engine oil level low. Air flow restricted. | Fill crankcase with proper capacity and weight of oil. Clean grass clippings and debris from around the engine's cooling fins and blower housing. |
| Engine hesitates at high RPM | Spark plug(s) gap too close. | Remove spark plug(s) and reset the gap to .030" . |
| Idles poorly | Spark plug(s) fouled, faulty or gap too wide. Dirty air cleaner. | Replace spark plug(s). Set plug(s) gap to .030" . Replace air cleaner cartridge/element or clean pre-cleaner, if so equipped. |
| Excessive vibration | Cutting blade loose or unbalanced. Damaged or bent cutting blade. | Tighten blade and spindle. Balance blade. Replace blade. |
| Mower will not mulch grass | Engine speed too low. Wet grass. Excessively high grass. Dull blade. | Place throttle in FAST (rabbit) position. Do not mow when grass is wet; wait until later to cut. Mow once at a high cutting height, then mow again at desired height or make a narrower cutting swath. Sharpen or replace blade. |
| Uneven cut | Deck not balanced properly. Dull blade. Uneven tire pressure. | Perform side-to-side deck adjustment. Sharpen or replace blade. Check tire pressure in all four tires. |

SECTION 12: MODELS J609H & Y609H PARTS LIST

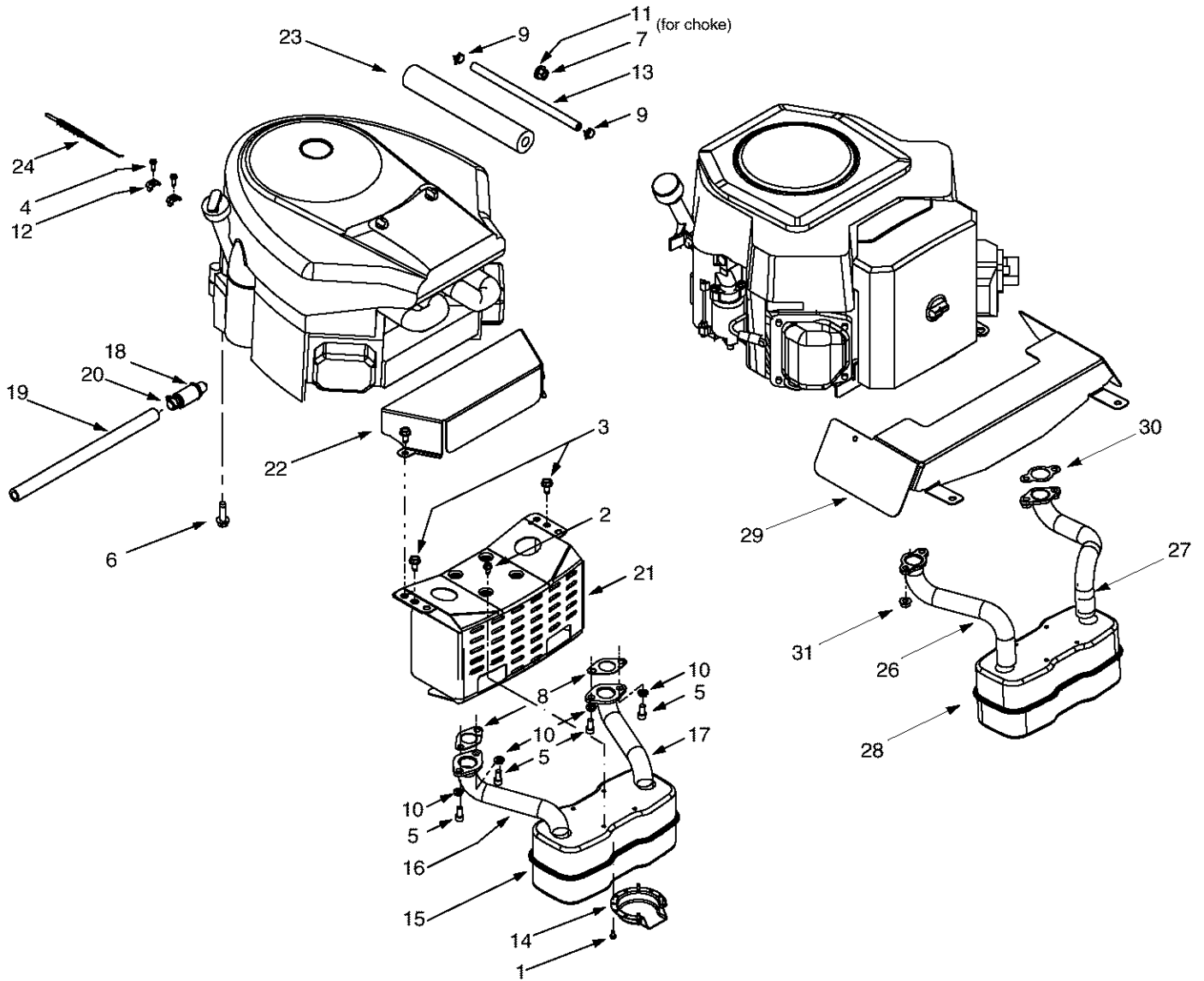

NOTE: Engine accessory parts are applicable to both model J609H and Y609H except where otherwise noted.

| REF. NO. | PART NO. | DESCRIPTION | REF. NO. | PART NO. | DESCRIPTION |
|----------|------------|------------------------------------|----------|-----------|---------------------------------------|
| 1 | 710-0227 | Self-tapping Screw, #8-18 x .5 | 17 | 751-0651 | LH Exhaust Pipe (Model J609H) |
| 2 | 710-0599 | Self-tapping Screw, 1/4-20 x .5 | 18 | 751-3140 | Oil Drain Valve |
| 3 | 710-0604A | Self-tapping Screw, 5/16-18 x .625 | 19 | 751-3141 | Oil Drain Hose |
| 4 | 710-1237 | Screw, #10-32 x .625 (Model J609H) | 20 | 751-3142 | Oil Drain Cap |
| 5 | 710-1314 | Socket Cap Screw, 5/16-18 x .625 | 21 | 783-0615B | Muffler Heat Shield |
| 6 | 710-1315 | Self-tapping Screw, 3/8-16 x 1.25 | 22 | 783-0625B | Engine Heat Shield (Model J609H) |
| 7 | 712-3017 | Hex Nut, 3/8-16 | 23 | 722-0263 | Foam (fits over fuel line) |
| 8 | 721-0460 | Exhaust Gasket (Model J609H) | 24 | 746-1086 | Throttle Cable (Model J609H) |
| 9 | 726-0205 | Hose Clamp | 25 | 746-1100 | Throttle Cable (Model Y609H) |
| 10 | 736-0119 | Lock Washer, 5/16 | 26 | 751-0645 | RH Exhaust Pipe (Model Y609H) |
| 11 | 736-0300 | Flat Washer | 27 | 751-0644A | LH Exhaust Pipe (Model Y609H) |
| 12 | 751B221535 | Casing Clamp (Model J609H) | 28 | 751-0805 | Muffler, Twin Inlet (Model Y609H) |
| 13 | 751-0535 | Fuel Line Hose | 29 | 783-1121 | Engine Heat Shield (Model Y609H) |
| 14 | 751-0564 | Muffler Deflector | 30 | 721-0377 | Exhaust Gasket (Model Y609H) |
| 15 | 751-0616 | Muffler, Twin Inlet (Model J609H) | 31 | 712-3086 | Flange Nut, M8 x 1.25-6 (Model Y609H) |
| 16 | 751-0650 | RH Exhaust Pipe (Model J609H) | | | |

Models J609H & Y609H

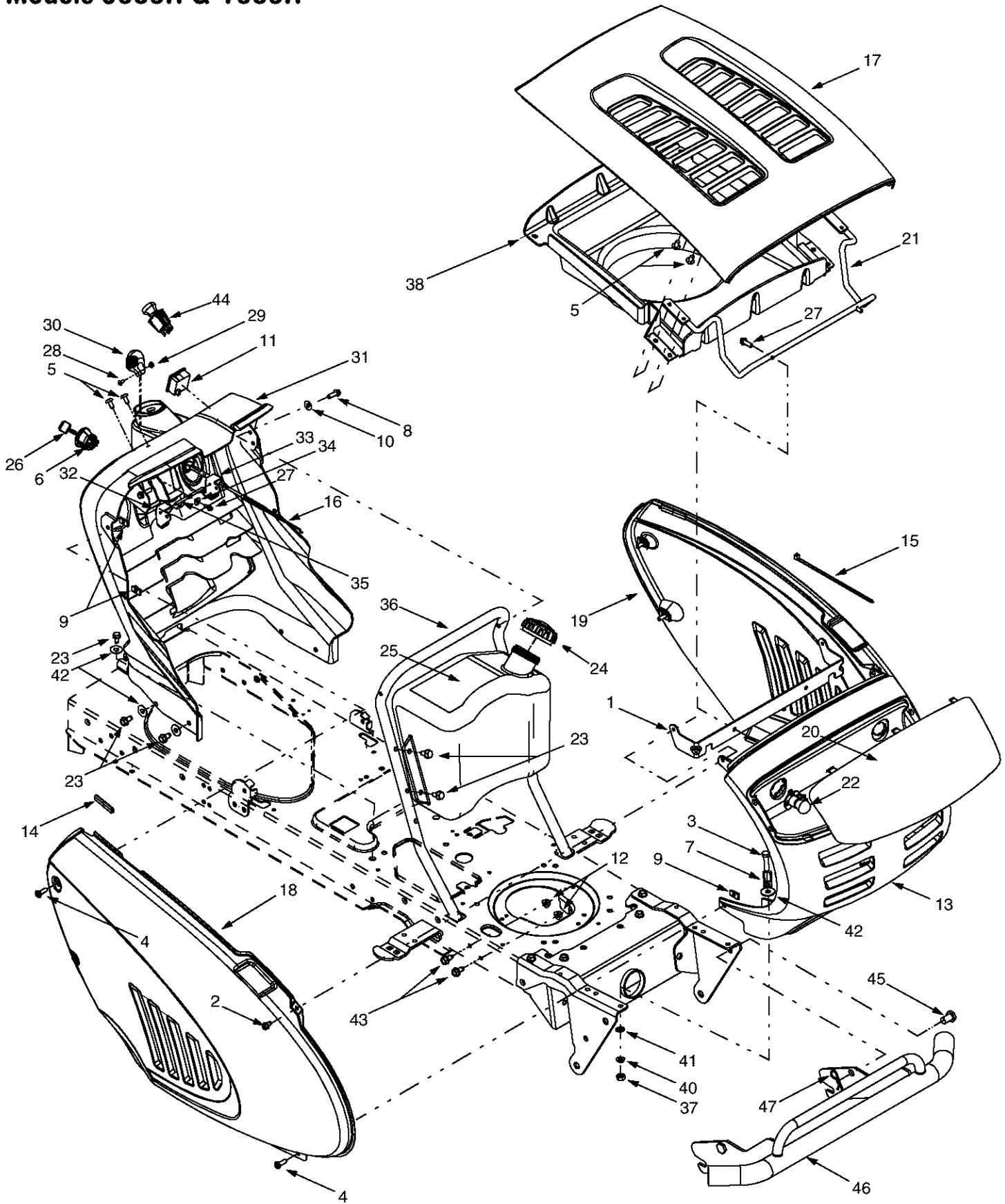

Models J609H & Y609H

| REF. NO. | PART NO. | DESCRIPTION |
|----------|-----------|-------------------------------------|
| 1 | 783-1346 | Grill Support Bracket (9-style) |
| 2 | 710-0599 | Self-tapping Screw, 1/4-20 x .5 |
| 3 | 710-0528 | Hex Cap Screw, 5/16-18 x 1.25 |
| 4 | 710-0924 | Phillips Pan Screw, 1/4-20 x .75 |
| 5 | 710-1017 | Truss Phillips Screw, 1/4-20 x .625 |
| 6 | 725-1741 | Ignition Switch |
| 7 | 726-0272 | Clamp, 9/16 |
| 8 | 710-0642 | Self-tapping Screw, 1/4-20 x .75 |
| 9 | 712-0292 | U-type Speed Nut, 1/4-20 |
| 10 | 736-0270 | Bell Washer, .265 x .75 x .062 |
| 11 | 725-1976 | Systems Indicator Monitor |
| 12 | 712-3004A | Hex Nut, 5/16-18 |
| 13 | 731-2119 | Grille (9-style) |
| 14 | 731-0511 | Trim Strip, 4 |
| 15 | 725-0175 | Cable Tie, 3/16 x .05 x 7.4 |
| 16 | 746-1085 | Choke Knob/Cable |
| 17 | 783-0783 | Hood (9-style) |
| 18 | 783-0784 | RH Side Panel (9-style) |
| 19 | 783-0785 | LH Side Panel (9-style) |
| 20 | 731-2118 | Headlight Lens (9-style) |
| 21 | 747-1162 | Hood Hinge Rod |
| 22 | 625-0051 | Headlight Assembly |
| 23 | 710-0604A | Self-tapping Screw, 5/16-18 x .625 |
| 24 | 751-0603 | Fuel Cap |
| 25 | 751-0658B | Fuel Tank, Three-gallon |
| 26 | 725-1745 | Ignition Key w/ plastic cover |
| | 725-1744 | Ignition Key w/o plastic cover |
| 27 | 710-0895 | Self-tapping Screw, 1/4-15 x .75 |
| 28 | 710-3217 | Truss Phillips Screw, #8-32 x .375 |
| 29 | 712-0142 | Hex Nut, #8-32 |
| 30 | 731-1857 | Throttle Control Knob |
| 31 | 731-2225B | Dash Panel, 8/9-style, Electric PTO |
| 32 | 731-2226 | Cruise Control Button |
| 33 | 731-2227 | Parking Brake Button |
| 34 | 736-0142 | Flat Washer, 9/32 x 1/2 x 1/16 |
| 35 | 747-1196 | Brake/Cruise Pivot Rod |
| 36 | 749-1087A | Dash Support Tube |
| 37 | 712-3010 | Hex Nut, 5/16-18 |
| 38 | 731-2270A | Hood Plenum (Model J609H) |
| | 731-2271A | Hood Plenum (Model Y609H) |
| 39 | 726-3046 | Ratchet Clip |
| 40 | 736-0119 | Lock Washer, 5/16 |
| 41 | 726-0201 | Speed Nut, .3125 |
| 42 | 736-3078 | Flat Washer, .349 x 1.0 x .063 |
| 43 | 710-1238 | Screw, 5/16-18 x .875 (Grade 5) |
| 44 | 725-1752 | Electric PTO Switch |
| 45 | 711-0332 | Clevis Pin, .50 x .78 |
| 46 | 768-0010 | Bumper Assembly |
| 47 | 714-0145 | Internal Cotter Pin |
| | 629-0469A | Headlight Wire Harness (Not Shown) |
| | 629-1071 | Tractor Wire Harness (Not Shown) |

Models J609H & Y609H

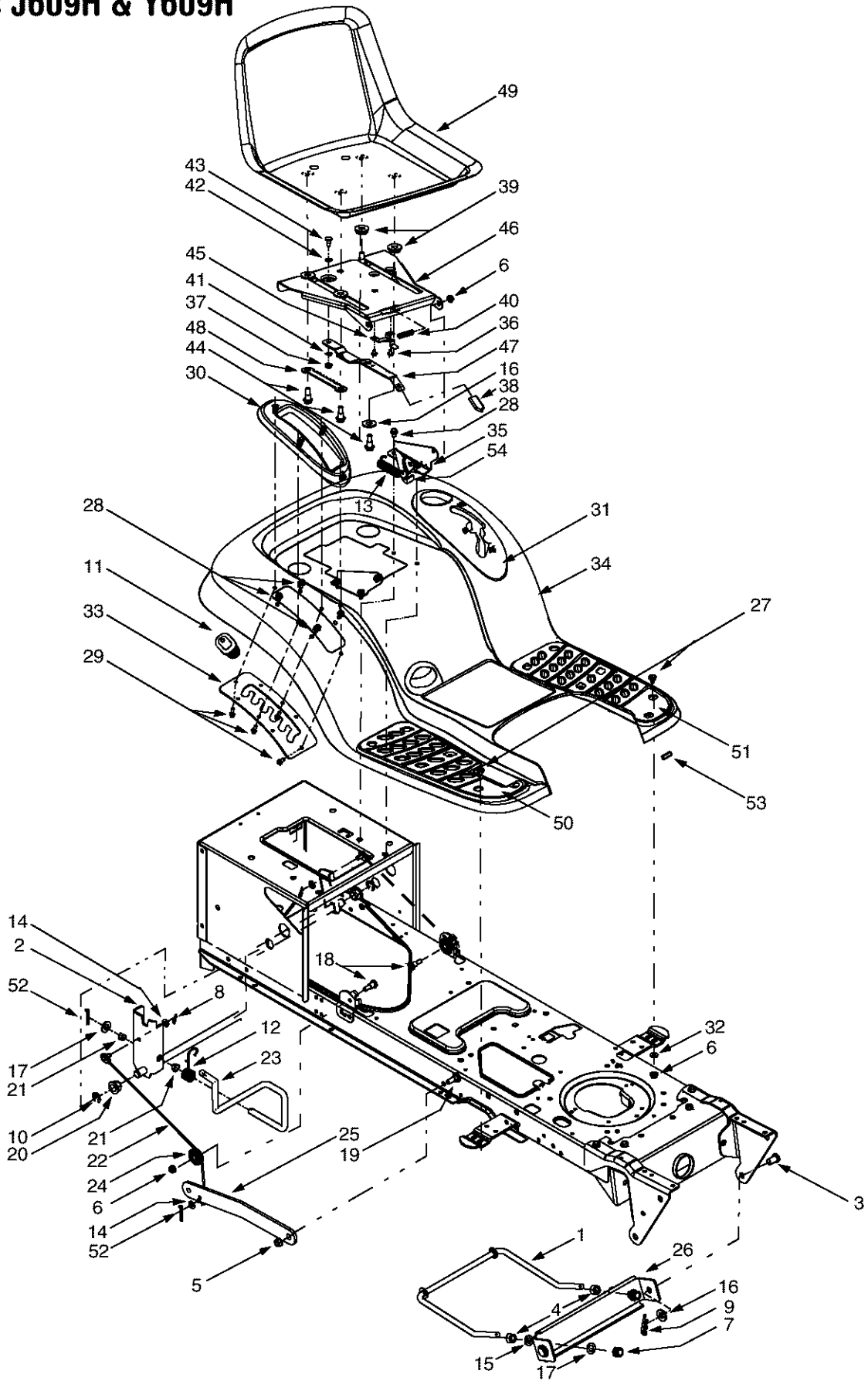

Models J609H & Y609H

| REF. NO. | PART NO. | DESCRIPTION |
|----------|-----------|-------------------------------------|
| 1 | 747-1130A | Deck Stabilizer Rod |
| 2 | 683-0197 | Lift Shaft Assembly |
| 3 | 711-0332 | Clevis Pin, .5 x .78 |
| 4 | 712-0206 | Hex Nut, 1/2-13 |
| 5 | 712-0431 | Flange Lock Nut, 3/8-16 |
| 6 | 712-3004A | Flange Lock Nut, 5/16-18 |
| 7 | 712-3083 | Hex Nut, 1/2-13 |
| 8 | 714-0104 | Internal Cotter Pin |
| 9 | 714-0145 | Internal Cotter Pin |
| 10 | 716-0106 | E-ring |
| 11 | 720-0311 | Handle Grip |
| 12 | 732-0874 | Torsion Spring |
| 13 | 732-1027 | Extension Spring, .872 x 3.4 |
| 14 | 736-0275 | Flat Washer, 5/16 |
| 15 | 736-0921 | Lock Washer, 1/2 |
| 16 | 736-3019 | Flat Washer, .31 x 1.062 x .134 |
| 17 | 736-3084 | Flat Washer, .51 x 1.12 x .06 |
| 18 | 738-0138A | Hex Cap Screw, 5/16-18 x .62 |
| 19 | 738-0143 | Shoulder Screw, 3/8-16 |
| 20 | 741-0225 | Hex Flange Bearing |
| 21 | 741-0715 | Snap Flange Bearing |
| 22 | 746-0968 | Lift Cable, 16.16 |
| 23 | 747-1111 | Lift Handle |
| 24 | 756-1154 | Roller Pulley |
| 25 | 783-0678A | Arm Lift |
| 26 | 783-0720A | Deck Stabilizer Bracket |
| 27 | 710-0260A | Carriage Bolt, 5/16 x .62 |
| 28 | 710-0604A | Self-tapping Screw, 5/16-18 x .625 |
| 29 | 710-0895 | Self-tapping Screw, 1/4-15 x .75 |
| 30 | 731-1990 | Lift Lever Cover |
| 31 | 731-2104A | Shift Lever Cover w/ Cup Holder |
| 32 | 736-3078 | Flat Washer, .349 x 1.0 x .063 |
| 33 | 783-0677 | Lift Adjustment Bracket |
| 34 | 783-0685B | Fender |
| 35 | 783-0715A | Seat Mounting Bracket |
| 36 | 710-1268 | Screw, #10-16 x .375 |
| 37 | 712-3027 | Hex Flange Lock Nut, 1/4-20 |
| 38 | 720-0309A | Seat Adjuster Grip |
| 39 | 731-1989 | Spacer |
| 40 | 732-0499 | Compression Spring, .41 x 1.5 |
| 41 | 736-0175 | Spring Washer, .265 x .562 x .025 |
| 42 | 736-0204 | Flat Washer, .344 x .62 x .03 |
| 43 | 738-0137A | Shoulder Screw, .340 x .285, 1/4-20 |
| 44 | 738-1007 | Shoulder Screw, .50 x .50, 3/8-16 |
| 45 | 783-0611 | Seat Stop |
| 46 | 783-0738 | Seat Pivot Bracket |
| 47 | 783-0739 | Seat Adjustment Lever |
| 48 | 783-0753 | Seat Adjustment Selector |
| 49 | 757-0348A | High Back Seat, Black |
| 50 | 735-0656 | RH Foot Pad |
| 51 | 735-0657 | LH Foot Pad |
| | 726-3046 | Foot Pad Clips (Not Shown) |
| 52 | 714-0111 | Cotter Pin |
| 53 | 731-0511 | Trim Strip |
| 54 | 783-0209 | LH Seat Lift Bracket |
| | 17239A | RH Seat Lift Bracket (Not Shown) |

Models J609H & Y609H

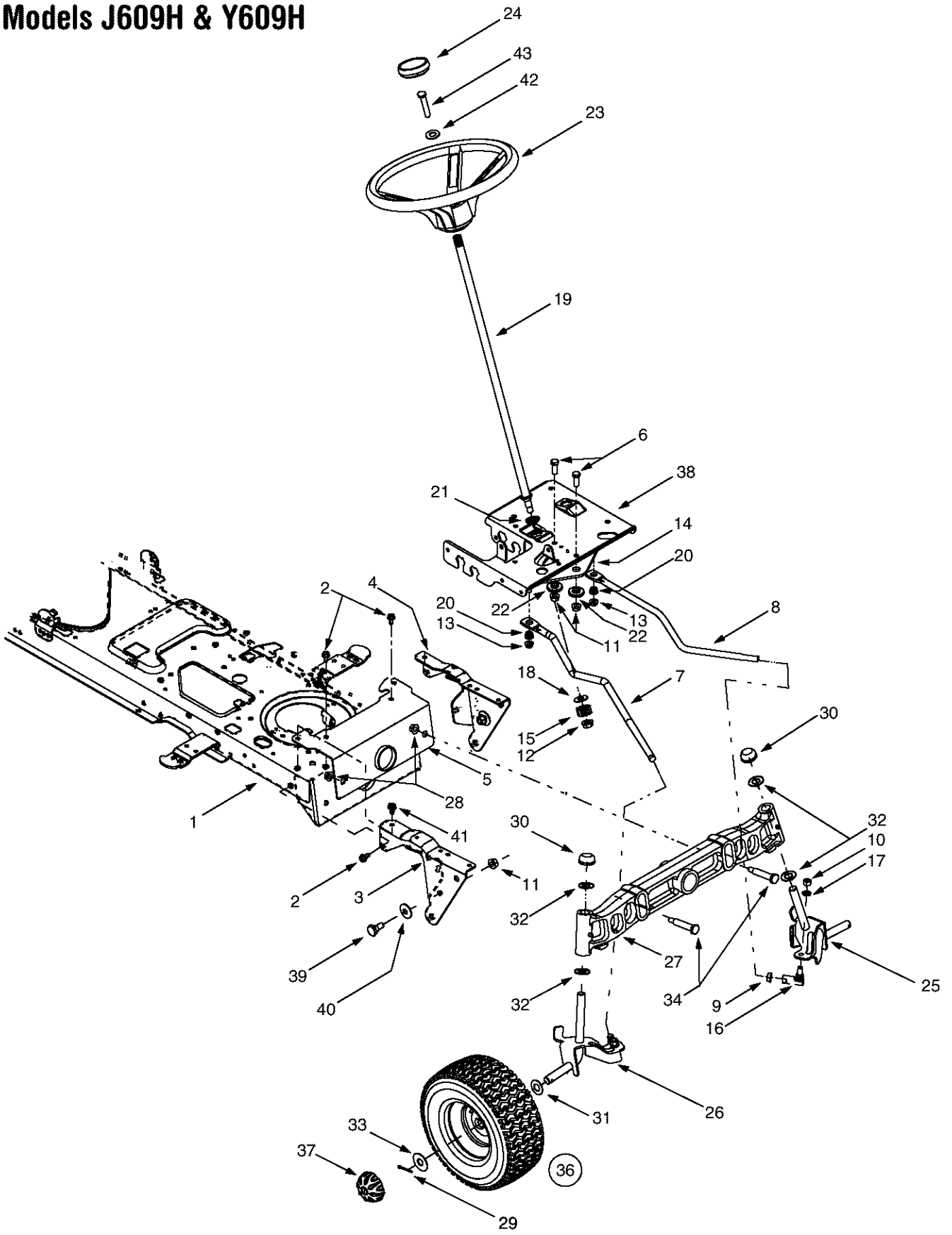

Models J609H & Y609H

| REF. NO. | PART NO. | DESCRIPTION |
|----------|-----------|--------------------------------------|
| 1 | 683-0304 | Lower Frame Assembly |
| 2 | 710-0604A | Self-tapping Screw, 16-18 x .625 |
| 3 | 783-0726A | RH Pivot Support Bracket |
| 4 | 783-0727 | LH Pivot Support Bracket |
| 5 | 783-0728 | Pivot Bar Bracket |
| 6 | 710-0514 | Hex Cap Screw, 3/8-16 x 1 (Grade 5) |
| 7 | 711-1408 | RH Drag Link |
| 8 | 711-1409A | LH Drag Link |
| 9 | 712-0240 | Jam Nut, 7/16-20 (Grade 2) |
| 10 | 712-0241 | Hex Nut, 3/8-24 (Grade 2) |
| 11 | 712-0431 | Flange Lock Nut, 3/8-16 |
| 12 | 712-0459 | Flange Lock Nut, 7/16-20 |
| 13 | 712-3004A | Flange Lock Nut, 5/16-18 |
| 14 | 717-1550C | Steering Gear, 11/90 Ratio |
| 15 | 717-1554 | Steering Pinion Gear |
| 16 | 723-0448A | Ball Joint, 7/16-20 |
| 17 | 736-0169 | Lock Washer, 3/8 |
| 18 | 736-3084 | Flat Washer, .51 x 1.12 x .06 |
| 19 | 738-1001A | Steering Shaft, .625 OD x 24.4 |
| 20 | 741-0475 | Plastic Bushing, .38 ID |
| 21 | 741-0656 | Hex Flange Bearing, 5/8 |
| 22 | 738-0372 | Shoulder Spacer, .38 ID |
| 23 | 631-0027 | Steering Wheel, 13.25 |
| 24 | 731-0220 | Steering Wheel Cap, Round |
| 25 | 638-0021 | LH Axle Assembly, .625 Diameter |
| 26 | 638-0022 | RH Axle Assembly, .625 Diameter |
| 27 | 719-0525B | Cast Iron Pivot Bar w/ Fittings, .75 |
| 28 | 712-0431 | Flange Lock Nut, 3/8-16 |
| 29 | 714-0470 | Cotter Pin |
| 30 | 726-0214 | Push Cap, .625 |
| 31 | 736-0162 | Flat Washer, .64 x 1.0 x .12 |
| 32 | 736-0187 | Flat Washer, .64 x 1.24 x .06 |
| 33 | 736-0285 | Flat Washer, .635 x 1.589 x .06 |
| 34 | 738-1011 | Shoulder Screw, .5 x 2.2, 3/8-16 |
| 35 | 710-0643 | Hex Bolt, 5/16-18 X 1 |
| 36 | 634-0105A | Wheel Assembly Complete, 15 x 6 x 6 |
| | 634-0172 | Rim Only w/ Plastic Bearing |
| | 734-0255 | Air Valve (Not Shown) |
| | 734-1731 | Tire Only, Square Shoulder |
| 37 | 734-2290 | Hub Cap |
| 38 | 783-0653D | Steering Support Bracket |
| 39 | 738-0143 | Shoulder Screw, 3/8-16 |
| 40 | 736-0331 | Bell Washer, .39 x 1.13 x .062 |
| 41 | 710-1260A | Self-tapping Screw, 5/16-18 x .75 |
| 42 | 736-0242 | Bell Washer, .34 x .872 |

Models J609H & Y609H

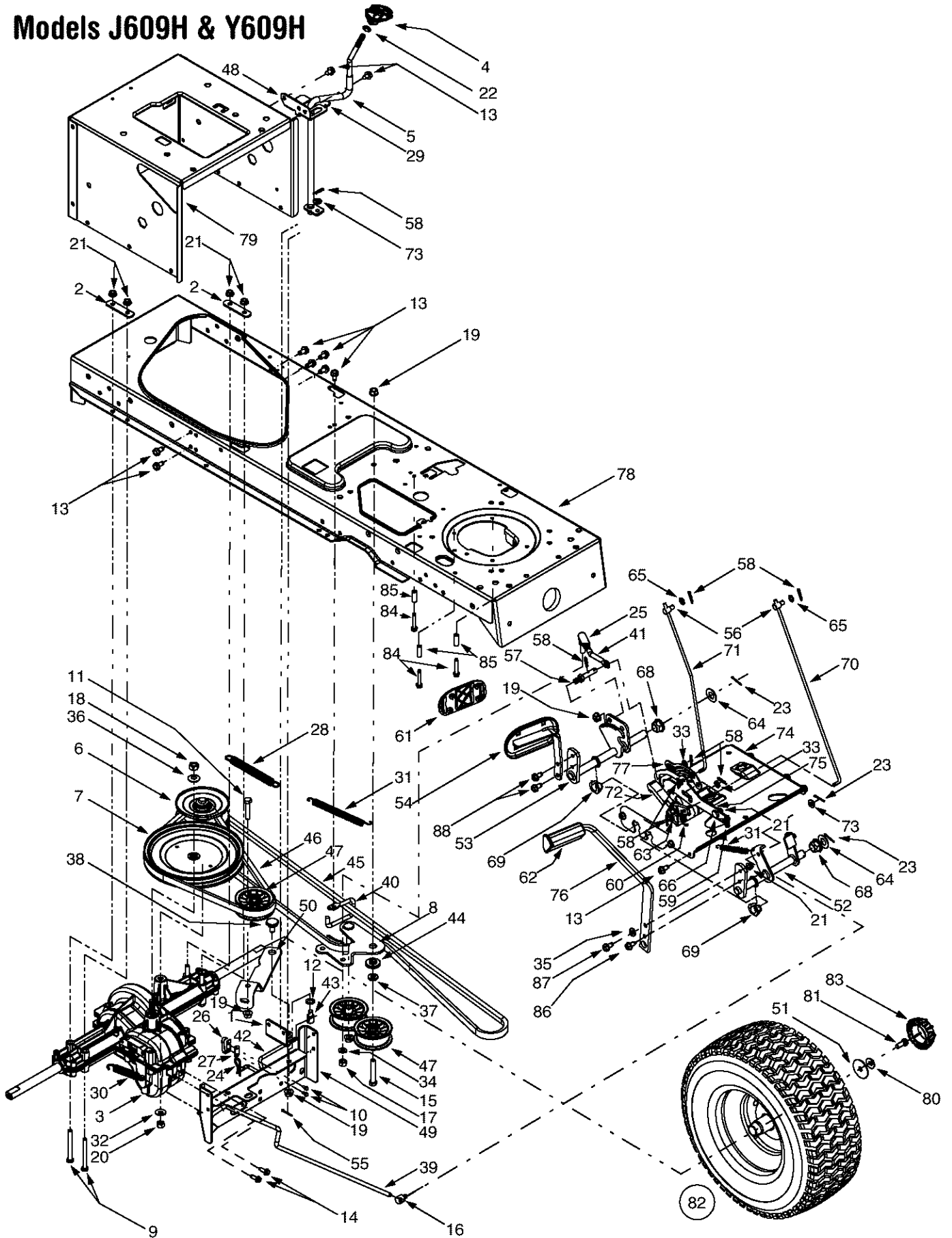

Models J609H & Y609H

| REF. NO. | PART NO. | DESCRIPTION | REF. NO. | PART NO. | DESCRIPTION |
|----------|-----------|--|----------|-----------|--|
| 1 | 783-1015 | Shift Lever Support | 46 | 754-0468 | Upper Drive Belt |
| 2 | 17840 | Transaxle Mounting Bracket | 47 | 756-0981A | Flat Idler, 2.75 OD |
| 3 | 618-0551 | Single-speed Transmission Assembly | 48 | 783-1016B | Speed Control Rod Bracket |
| 4 | 631-0009A | Shifter Knob | 49 | 783-0667B | Transmission Torque Bracket |
| 5 | 647-0045 | Shift Lever | 50 | 783-0669 | Idler Bracket |
| 6 | 656-0048 | Variable-speed Pulley Assembly | 51 | 736-0430 | Flat Washer, .350 x 1.59 x .062 |
| 7 | 656-0051A | Transmission Pulley, 8.5 x .5-36 | 52 | 647-0031 | Brake Control Assembly |
| 8 | 683-0251 | Double-idler Bracket | 53 | 647-0032 | Speed Control Assembly |
| 9 | 710-0176 | Hex Cap Screw, 5/16-18 x 2.75 | 54 | 683-0266 | Drive Pedal Assembly |
| 10 | 710-0227 | Self-tapping Screw, #8-18 x .5 | 55 | 714-0470 | Cotter Pin, 1/8 x 1.25 |
| 11 | 710-0347 | Hex Cap Screw, 3/8-16 x 1.75 | 56 | 711-0736 | Ferrule, 1/4-20 |
| 12 | 736-0272 | Flat Washer, .51 x 1.0 x .060 | 57 | 711-1363 | Pin, 3/8-16 x 2.43 |
| 13 | 710-0604A | Self-tapping Screw, 5/16-18 x .625 | 58 | 714-0104 | Cotter Pin |
| 14 | 710-0642 | Self-tapping Screw, 1/4-20 x .75 | 59 | 732-0437 | Compression Spring, .34 OD x 1.0 |
| 15 | 710-3011 | Hex Cap Screw, 3/8-16 x 2.25 | 60 | 732-0955 | Extension Spring, .50 OD x 1.41 |
| 16 | 711-0677 | Ferrule, 5/16-18 | 61 | 735-0662 | Drive Pedal Pad |
| 17 | 712-0241 | Hex Nut, 3/8-24 | 62 | 735-3049 | Brake Pedal Pad |
| 18 | 712-0378 | Hex Nut, 7/16-20 | 63 | 736-0142 | Flat Washer, .281 x .5 x .063 |
| 19 | 712-0431 | Flange Lock Nut, 3/8-16 | 64 | 736-0187 | Flat Washer, .64 x 1.24 x .06 |
| 20 | 712-3017 | Hex Nut, 3/8-16 | 65 | 736-0204 | Flat Washer, .344 x .062 x .03 |
| 21 | 712-3004A | Flange Lock Nut, 5/16-18 | 66 | 738-0155 | Shoulder Screw, .437 x 1.62 |
| 22 | 712-3008 | Jam Nut, 3/8-16 | 67 | 738-0507B | Shoulder Screw, .5 x .434 |
| 23 | 714-0111 | Cotter Pin | 68 | 741-0225 | Hex Flange Bearing |
| 24 | 714-0149B | Internal Cotter Pin | 69 | 741-3065A | Split Hex Flange Bearing |
| 25 | 723-3018 | Ball Joint | 70 | 747-1137 | Cruise Control Rod |
| 26 | 725-1644 | Short Spring Switch | 71 | 747-1138 | Brake Lock Control Rod |
| 27 | 726-0320 | Insulator Nut Plate | 72 | 748-0413 | Cruise Latch |
| 28 | 732-0384 | Extension Spring, .62 Dia. x 6.12 | 73 | 736-0275 | Flat Washer, .344 x .688 x .065 |
| 29 | 732-0525 | Compression Spring Clip | 74 | 783-0653D | Steering Support Bracket |
| 30 | 732-0716 | Extension Spring, .59 OD x 4 | 75 | 783-0732 | Drive Lockout Bracket |
| 31 | 732-0963 | Extension Spring, .50 Dia. x 6.37 (hooks to flange, 783-0650, in frame) | 76 | 783-0773 | Brake Pedal |
| 32 | 736-0105 | Bell Washer, .401 x .87 x .063 | 77 | 783-0780A | Neutral Return Bracket |
| 33 | 736-0140 | Flat Washer, .385 x .62 x .063 | 78 | 683-0304 | Lower Frame Assembly |
| 34 | 736-0169 | Lock Washer, 3/8 | 79 | 783-1031A | Hitch Plate |
| 35 | 736-3008 | Flat Washer, .344 x .750 x .120 | 80 | 736-0242 | Bell Washer, .34 x .872 |
| 36 | 736-0407 | Bell Washer, .45 x 1.0 x .602 | 81 | 710-0627 | Hex Cap Screw, 5/16-24 x .75 |
| 37 | 736-3010 | Flat Washer, .407 x .812 x .135 | 82 | 634-0104 | Wheel Assembly Complete, 20 x 8 x 8 |
| 38 | 738-0322 | Shoulder Screw, .625 x .217 | | 634-0070 | Rim Only |
| 39 | 747-1122 | Brake Rod | | 734-0255 | Air Valve (Not Shown) |
| 40 | 747-1123A | Belt Guard | | 734-1730 | Tire Only, 20 x 8 x 8, Square Shoulder |
| 41 | 747-1127 | Idler Adjustment Rod, 3/8 | 83 | 734-2290A | Hub Cap |
| 42 | 747-0047A | Shift Rod | 84 | 710-0809 | Self-tapping Screw, 1/4-20 x 1.25 |
| 43 | 711-0736 | Adjustment Ferrule, 1/4-20 x 1.0 | 85 | 750-0566A | Spacer |
| 44 | 738-0372 | Shoulder Spacer, .38 ID | 86 | 710-0650 | Self-tapping Screw, 5/16-18 x .875 |
| 45 | 754-0467 | Lower Drive Belt | 87 | 710-1260A | Self-tapping Screw, 5/16-18 x .75 |

IMPORTANT: For a proper working machine, use Factory Approved Parts. **V-belts** are designed to engage and disengage safely. A substitute (non OEM) V-belt can be dangerous by not disengaging completely.

NOTE: For **painted parts**, please refer to the list of color codes below. Please add the applicable color code, wherever needed, to the part number to order a replacement part. For instance, if a part numbered 700-xxxx is painted Powder Black, the part number to order would be 700-xxxx-0637.
 MTD Red: 0638
 Oyster Gray: 0662
 Powder Black: 0637

Models J609H & Y609H

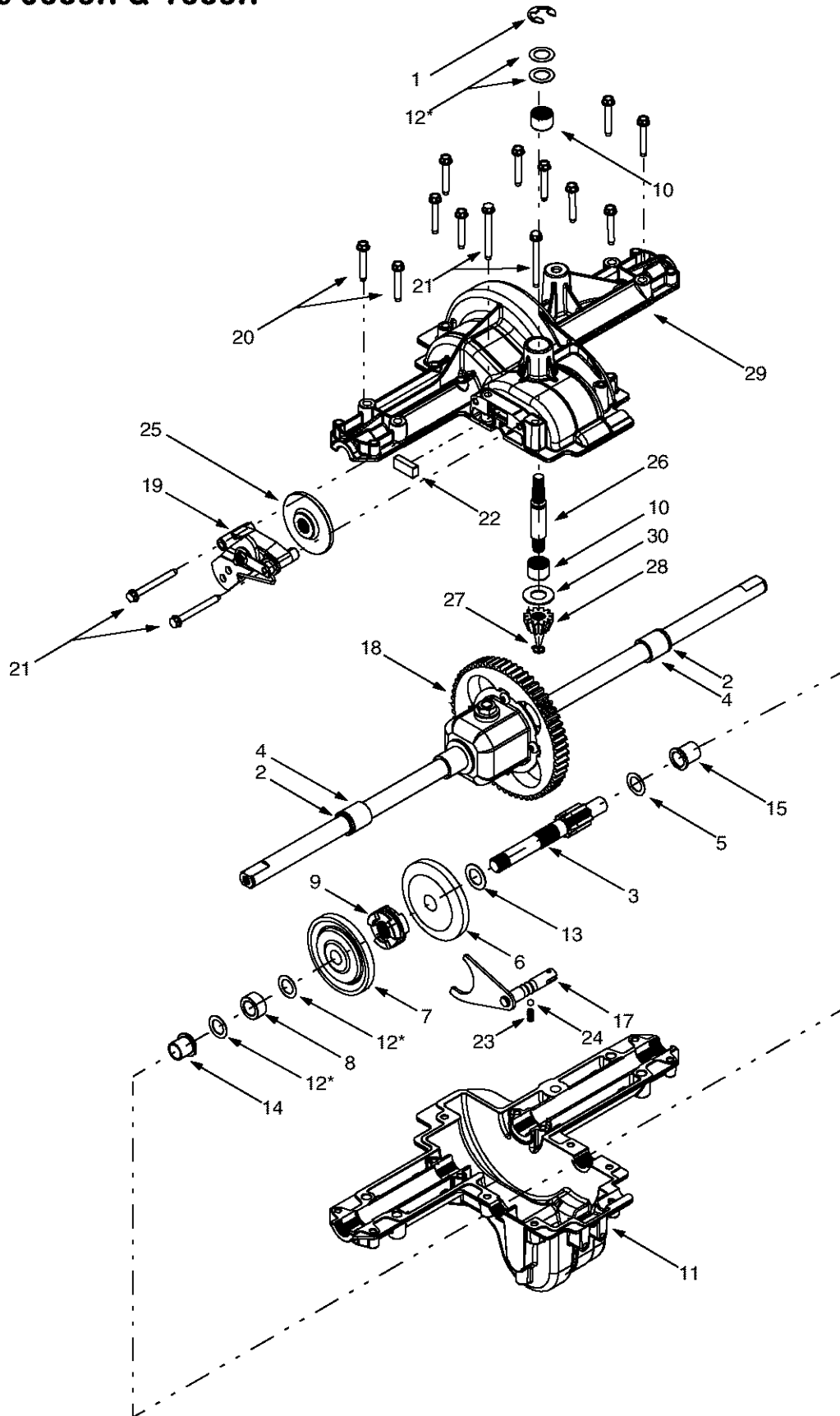

Models J609H & Y609H

| REF. NO. | PART NO. | DESCRIPTION |
|----------|-----------|------------------------------------|
| 1 | 716-0231 | E-ring, .75 |
| 2 | 721-0338 | Seal, .75 x 1.0 x .125 |
| 3 | 711-1431 | Drive Shaft |
| 4 | 741-0340 | Sleeve Bearing, .75 x .1.0 x 1.0 |
| 5 | 736-0495 | Thrust Washer, 1.0 x .632 x .0 |
| 6 | 717-1362 | 42-tooth Bevel Gear |
| 7 | 717-1363 | 42-tooth Bevel Gear |
| 8 | 750-1234 | Spacer, .633 x 1.0 x .513 |
| 9 | 718-0228 | Clutch Collar |
| 10 | 741-0525 | Needle Bearing, .625 x .875 |
| 11 | 719-0394 | Lower Housing |
| 12a | 736-0336 | Flat Washer, 5/8 x 1.0 x .030* |
| 12b | 736-0337 | Flat Washer, 5/8 x 1.0 x .040* |
| 12c | 736-0349 | Flat Washer, 5/8 x 1.0 x .020* |
| 13 | 736-0519 | Flat Washer, .70 x 1.125 x .031 |
| 14 | 741-0336 | Flange Bearing, 5/8 x 3/4 x 3/4 |
| 15 | 741-0337 | Flange Bearing, 5/8 x 3/4 x 15/16 |
| 16 | 750-1238 | Spacer, .635 x 1.0 x .27 |
| 17 | 611-0133 | Detent Shaft Assembly |
| 18 | 618-0424 | Differential Assembly |
| 19 | 661-0006 | Brake Assembly |
| 20 | 710-1325 | Self-tapping Screw, 1/4-20 x 1.625 |
| 21 | 710-1206 | Self-tapping Screw, 1/4-20 x 2.375 |
| 22 | 717-0678 | Brake Pad |
| 23 | 732-0863 | Compression Spring |
| 24 | 741-0862 | Detent Ball |
| 25 | 761-0202 | Brake Disc |
| 26 | 711-1430 | Input Shaft |
| 27 | 716-0108 | Retaining Ring, .437 |
| 28 | 717-1464 | 14-tooth Bevel Pinion |
| 29 | 719-0391A | Upper Housing |
| 30 | 736-0723 | Thrust Washer, .635 x 1.25 x .042 |

*Use applicable flat washer (12a, 12b or 12c) in this application allowing proper end-play as instructed in *MTD's* Service Manual.

Models J609H & Y609H

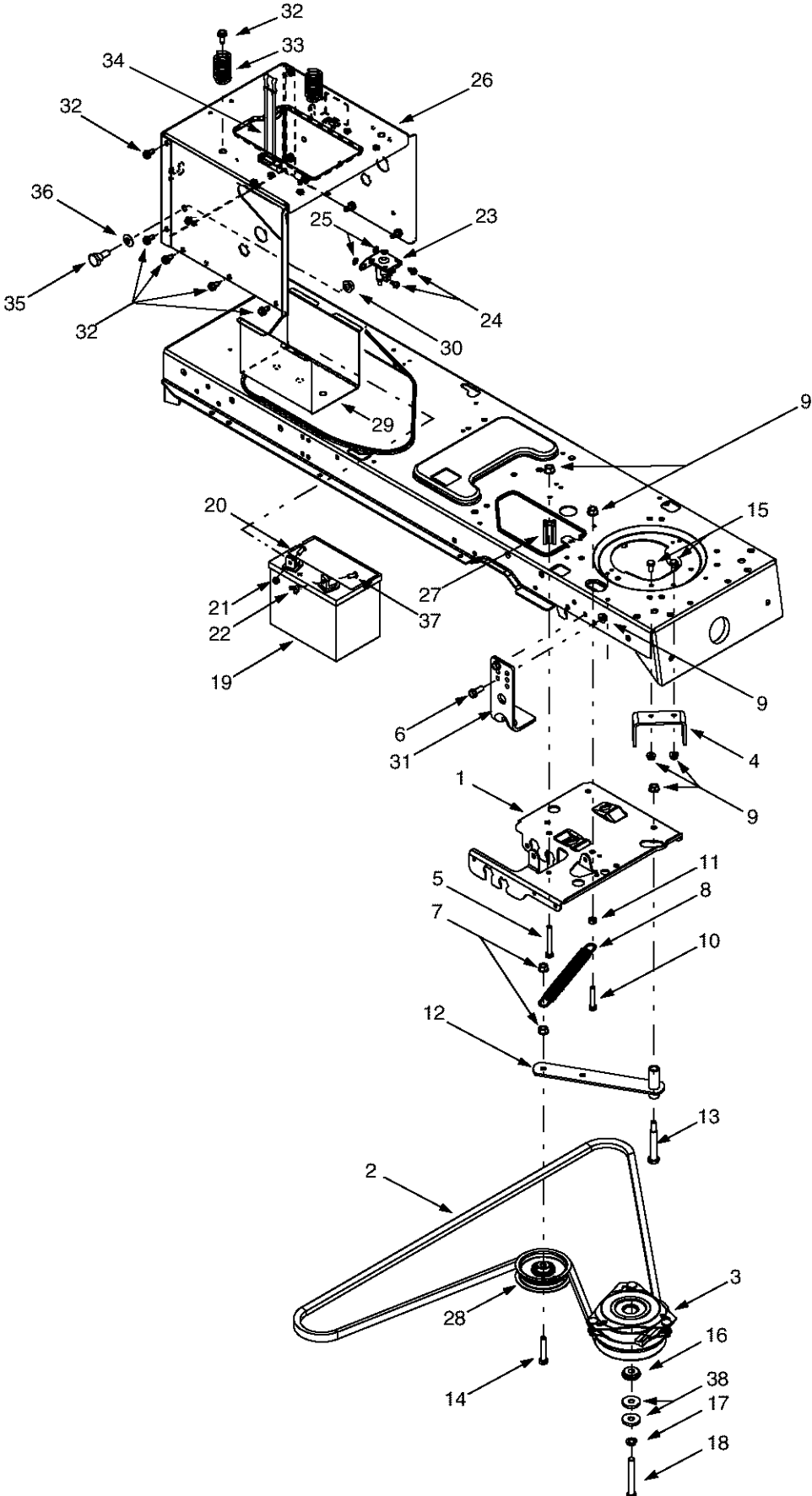

Models J609H & Y609H

| REF. NO. | PART NO. | DESCRIPTION |
|----------|-----------|---|
| 1 | 783-0653D | Steering Support Bracket |
| 2 | 754-0474 | PTO Belt |
| 3 | 717-1708 | Electric PTO Clutch |
| 4 | 783-1003 | Electric Clutch Anti-rotation Bracket |
| 5 | 710-0859 | Hex Cap Screw, 3/8-16 x 2.5 |
| 6 | 710-1238 | Hex Head Washer Screw, 5/16-18 x .875 |
| 7 | 712-0431 | Flange Lock Nut, 3/8-16 |
| 8 | 732-0978 | Extension Spring, .62 x 5.62 |
| 9 | 712-3004A | Flange Lock Nut, 5/16-18 |
| 10 | 710-3180 | Hex Cap Screw, 5/16-18 x 1.75 |
| 11 | 712-3010 | Hex Nut, 5/16-18 |
| 12 | 683-0297 | Idler Bracket Assembly |
| 13 | 738-3056 | Shoulder Screw, 1/2 x 2.5 |
| 14 | 710-3144 | Hex Cap Screw, 3/8-16 x 2.0 |
| 15 | 710-3025 | Hex Cap Screw, 5/16-18 x .625 |
| 16 | 738-0785 | Shoulder Spacer, 1.38 x .445 x .36 |
| 17 | 736-0171 | Lock Washer, 7/16 |
| 18 | 710-3157 | Hex Cap Screw, 7/16-20 x 3.25 (Grade 5) |
| 19 | 725-1706 | 12-volt Battery, 270 CCA |
| 20 | 710-0751 | Hex Cap Screw, 1/4-20 x .62 |
| 21 | 712-0271 | Hex Sems Nut, 1/4-20 |
| 22 | 712-3087 | Wing Nut, 1/4-20 |
| 23 | 725-1426 | Solenoid, 12-Volt, 100 Amp |
| 24 | 710-0599 | Self Tapping Screw, 1/4-20 x .5 |
| 25 | 736-0222 | Lock Washer, 1/4 |
| 26 | 783-1031A | Hitch Plate |
| 27 | 748-0415A | Spacer, 3/8 x 1.54 |
| 28 | 756-0627B | Idler Pulley, 3.5 |
| 29 | 783-0349 | Battery Tray |
| 30 | 712-0459 | Flange Lock Nut, 7/16-20 |
| 31 | 783-0891B | Deck Stop |
| 32 | 710-0604A | Self Tapping Screw, 5/16-18 x .625 |
| 33 | 732-3080 | Compression Spring, 1.28 x 3.5 |
| 34 | 723-0444 | Battery Strap |
| 35 | 738-1020 | Shoulder Screw, .625 x .5, 7/16-20 |
| 36 | 736-0407 | Bell Washer, .45 x 1.0 x .062 |
| 37 | 738-1132 | Shoulder Screw, 1/4-20, .25 x .15 |
| 38 | 736-0322 | Flat Washer, .45 x 1.25 x .164 |

IMPORTANT: For a proper working machine, use Factory Approved Parts. **V-belts** are designed to engage and disengage safely. A substitute (non OEM) V-belt can be dangerous by not disengaging completely.

NOTE: For **painted parts**, please refer to the list of color codes below. Please add the applicable color code, wherever needed, to the part number to order a replacement part. For instance, if a part numbered 700-xxxx is painted Powder Black, the part number to order would be 700-xxxx-0637.
 MTD Red: 0638
 Oyster Gray: 0662
 Powder Black: 0637

Models J609H & Y609H

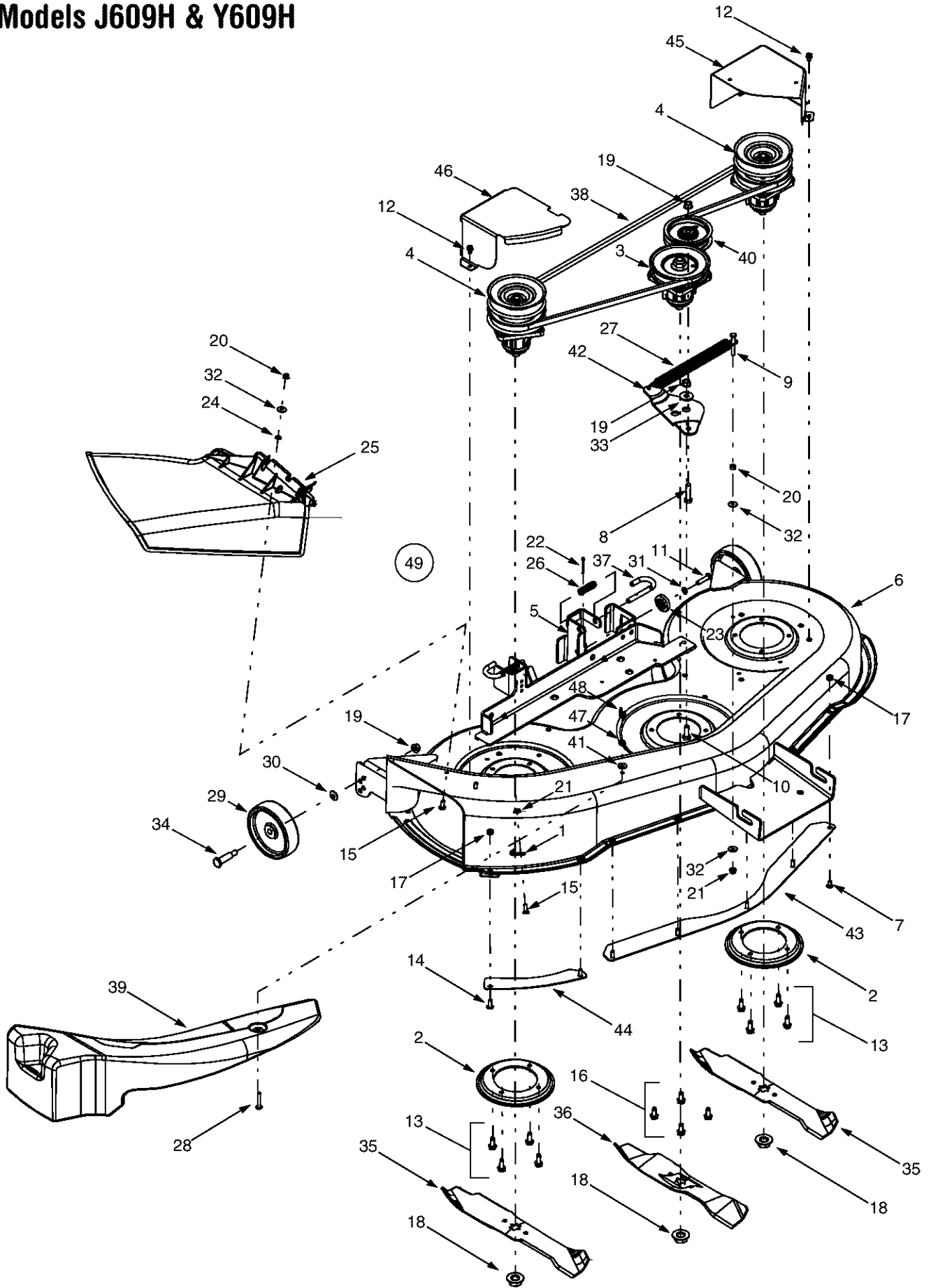

Models J609H & Y609H

| REF. NO. | PART NO. | DESCRIPTION |
|----------|-----------|---|
| 1 | 16606 | Retainer Hook |
| 2 | 17982 | Spindle Reinforcement Plate |
| 3 | 618-0240A | Spindle Assembly, 5.0 Dia. |
| | 756-1187 | Pulley Only |
| 4 | 618-0241 | Double Pulley Spindle Assembly |
| | 756-0603 | Pulley Only |
| 5 | 683-0254 | Deck Adjustment Bracket w/ Weld Nut |
| 6 | 683-0265C | 46-inch Deck Shell |
| 7 | 710-0167 | Carriage Screw, 1/4-20 x .50 |
| 8 | 710-0344 | Hex Cap Screw, 3/8-16 x 1.5 |
| 9 | 710-0501 | Hex Cap Screw, 1/4-20 x 2.0 |
| 10 | 710-0514 | Hex Cap Screw, 3/8-16 x 1.0 |
| 11 | 710-0528 | Hex Cap Screw, 5/8-18 x 1.25 |
| 12 | 710-0599 | Self-tapping Screw, 1/4-20 x .5 |
| 13 | 710-0650 | Self-tapping Screw, 15/16-18 x .875 |
| 14 | 710-0703 | Hex Screw, 1/4-20 x .75 |
| 15 | 710-0751 | Hex Cap Screw, 1/4-20 x .62 |
| 16 | 710-1260A | Self-tapping Screw, 5/16-18 x .75 |
| 17 | 712-0271 | Hex Sems Nut, 1/4-20 |
| 18 | 712-0417A | Hex Flange Nut, 5/8-18 |
| 19 | 712-0431 | Flange Lock Nut, 3/8-16 |
| 20 | 712-3006 | Hex Nut, 1/4-20 |
| 21 | 712-3027 | Hex Flange Lock Nut, 1/4-20 |
| 22 | 714-0470 | Cotter Pin, 1/8 x 1.25 |
| 23 | 717-1553A | Deck Adjustment Gear |
| 24 | 726-0233 | Push Nut, .25 x .5 |
| 25 | 731-1032B | Side Discharge Chute Assembly |
| 26 | 732-0306 | Compression Spring, .406 x .531 x 1.75 |
| 27 | 732-0594A | Extension Spring, .91 x 7.3 |
| 28 | 710-0578 | Screw, 1/4-20 x 1.5 |
| 29 | 734-0973 | Deck Wheel, 5 x 1.38 |
| 30 | 736-0105 | Bell Washer, .401 x .87 x .063 |
| 31 | 736-0119 | Lock Washer, 5/16 |
| 32 | 736-0270 | Bell Washer, .265 x .75 x .062 |
| 33 | 738-0347 | Shoulder Spacer, .625 x 1.16 |
| 34 | 738-0373 | Shoulder Screw |
| 35 | 742-0611 | Three-in-one Blade, Star Center, 16.28" |
| 36 | 742-0612 | Three-in-one Blade, Star Center, 14.88" |
| 37 | 747-1116 | Deck Release Pin |
| 38 | 754-0349 | Deck Belt, Poly |
| 39 | 731-1636 | Mulch Plug |
| 40 | 756-0627B | Idler Pulley, 3.5 |
| 41 | 736-0173 | Flat Washer, .28 x .74 x .063 |
| 42 | 783-0139A | Idler Bracket |
| 43 | 783-0141 | Center Deck Skirt |
| 44 | 783-0142 | RH Deck Skirt |
| 45 | 783-0747 | LH Belt Cover |
| 46 | 783-0805A | RH Belt Cover |
| 47 | 712-3006 | Hex Nut, 1/4-20 |
| 48 | 712-3087 | Wing Nut, 1/4-20 |
| 49 | 753-0874 | 46-inch Deck Assembly Complete (w/o Mulch Kit) |

IMPORTANT: For a proper working machine, use Factory Approved Parts. **V-belts** are designed to engage and disengage safely. A substitute (non OEM) V-belt can be dangerous by not disengaging completely.

MANUFACTURER'S LIMITED WARRANTY FOR:



The limited warranty set forth below is given by MTD PRODUCTS INC ("MTD") with respect to new merchandise purchased and used in the United States, its possessions and territories.

MTD warrants this product against defects in material and workmanship for a period of two (2) years commencing on the date of original purchase and will, at its option, repair or replace, free of charge, any part found to be defective in material or workmanship. This limited warranty shall only apply if this product has been operated and maintained in accordance with the Operator's Manual furnished with the product, and has not been subject to misuse, abuse, commercial use, neglect, accident, improper maintenance, alteration, vandalism, theft, fire, water or damage because of other peril or natural disaster. Damage resulting from the installation or use of any accessory or attachment not approved by MTD Products Inc. for use with the product(s) covered by this manual will void your warranty as to any resulting damages.

Normal wear parts or components thereof are subject to separate terms as follows: All normal wear part or component failures will be covered on the product for a period of 90 days regardless of cause. After 90 days, but within the two year period, normal wear part failures will be covered ONLY IF caused by defects in material or workmanship of OTHER component parts. Normal wear parts and components include, but are not limited to, belts, blades, blade adapters, grass bags, rider deck wheels, seats, snow thrower skid shoes, shave plates and tires. Batteries are covered by a 90-day limited replacement warranty.

HOW TO OBTAIN SERVICE: Warranty service is available, WITH PROOF OF PURCHASE THROUGH YOUR LOCAL AUTHORIZED SERVICE DEALER. To locate the dealer in your area, please check for a listing in the Yellow Pages or contact the Customer Service Department of MTD PRODUCTS INC by calling 1-800-800-7310 or writing to P.O. Box 368022, Cleveland, Ohio 44136-9722.

This limited warranty does not provide coverage in the following cases:

- a. The engine or component parts thereof. These items carry a separate manufacturer's warranty. Please refer to the applicable manufacturer's warranty on these items.
- b. Log splitter pumps, valves and cylinders have a separate one year warranty.

- c. Routine maintenance items such as lubricants, filters, blade sharpening and tune-ups, or adjustments such as brake adjustments, clutch adjustments or deck adjustments; and normal deterioration of the exterior finish due to use or exposure.
- d. MTD does not extend any warranty for products sold or exported outside of the United States of America, its possessions and territories, except those sold through MTD's authorized channels of export distribution.

No implied warranty, including any implied warranty of merchantability or fitness for a particular purpose, applies after the applicable period of express written warranty above as to the parts as identified. No other express warranty or guaranty, whether written or oral, except as mentioned above, given by any person or entity, including a dealer or retailer, with respect to any product shall bind MTD. During the period of the Warranty, the exclusive remedy is repair or replacement of the product as set forth above. (Some states do not allow limitations on how long an implied warranty lasts, so the above limitation may not apply to you.)

The provisions as set forth in this Warranty provide the sole and exclusive remedy arising from the sales. MTD shall not be liable for incidental or consequential loss or damages including, without limitation, expenses incurred for substitute or replacement lawn care services, for transportation or for related expenses, or for rental expenses to temporarily replace a warranted product. (Some states do not allow the exclusion or limitation of incidental or consequential damages, so the above exclusion or limitation may not apply to you.)

In no event shall recovery of any kind be greater than the amount of the purchase price of the product sold. Alteration of the safety features of the product shall void this Warranty. You assume the risk and liability for loss, damage, or injury to you and your property and/or to others and their property arising out of the use or misuse or inability to use the product.

This limited warranty shall not extend to anyone other than the original purchaser, original lessee or the person for whom it was purchased as a gift.

How State Law Relates to this Warranty: This limited warranty gives you specific legal rights, and you may also have other rights which vary from state to state.