

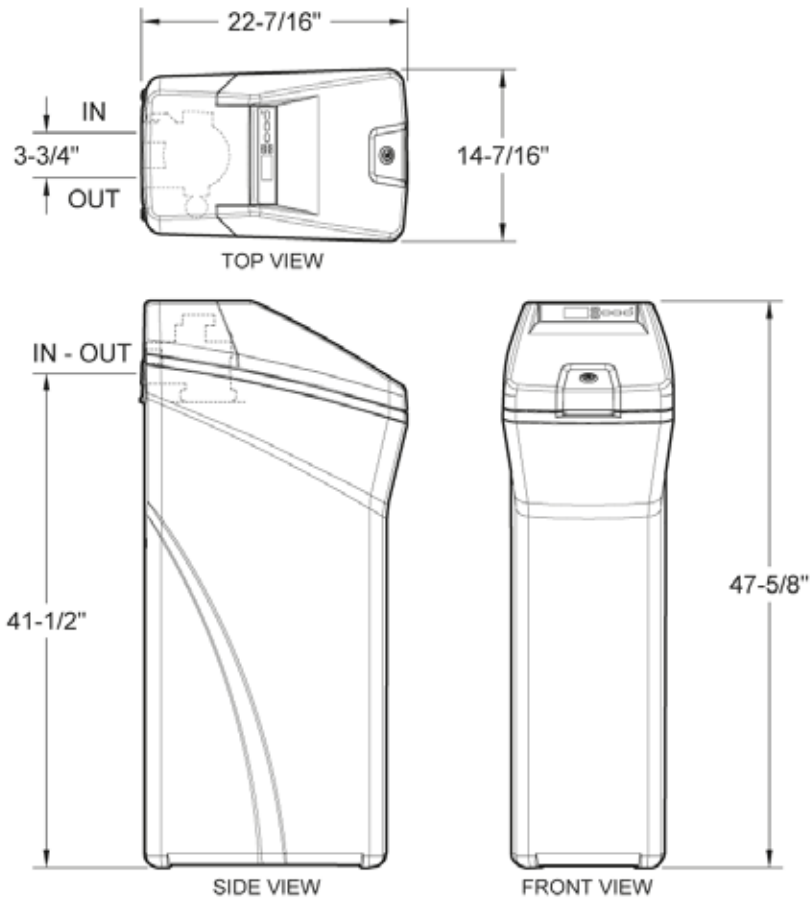

**GE Appliances**

## GXSH45V – GE Water Softener



Above illustration intended for dimensional reference only. Refer to photograph for actual product appearance.

**Specification Revised 3/13**  
**380233**

**Salt Capacity** – 230 lbs.

**Important:** All units must be installed according to local codes.

**Note:** Before installing, consult installation instructions packed with product for current dimensional data.



GXSH45V conforms to ANSI/NSF 44 for specifically claimed performance.

For answers to your Monogram®, GE Profile™ or GE appliance questions, visit our website at [GEAppliances.com](http://GEAppliances.com) or call GE Answer Center® service, 800.626.2000.



**GE Appliances**

---

## **GXSH45V – GE Water Softener**

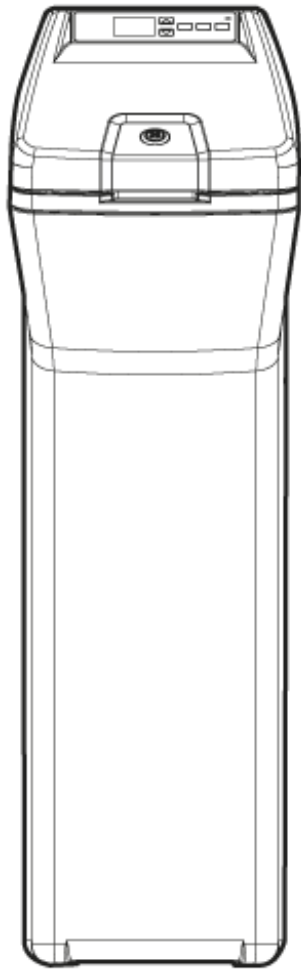

### **Features and Benefits**

- Easy to use up-front electronic controls with status light indicator
  - 45,100 Grain Capacity
  - Efficiency (5120 gpg)
  - Maximum Hardness Removal (160 gpg) / Maximum Iron Removal (10 ppm)
  - Salt Capacity (230 lbs)
  - GE Exclusive Custom Select blending valve allows you to select how soft you want your water.
  - GE Exclusive Salt Saver helps reduce salt consumption and uses up to 34% less salt\*
  - GE Exclusive Days to Empty makes sure you never have to guess when to refill the salt tank
  - Uses up to 35% less water\*
  - Self-cleaning sediment filter protects your home's plumbing
  - Plumbing connection up to 1.25"
- \*Based on internal analysis. Verses GE water softeners manufactured prior to 2009
- Model GXSH45V

**Specification Revised 3/13  
380233**