

Installation Instructions

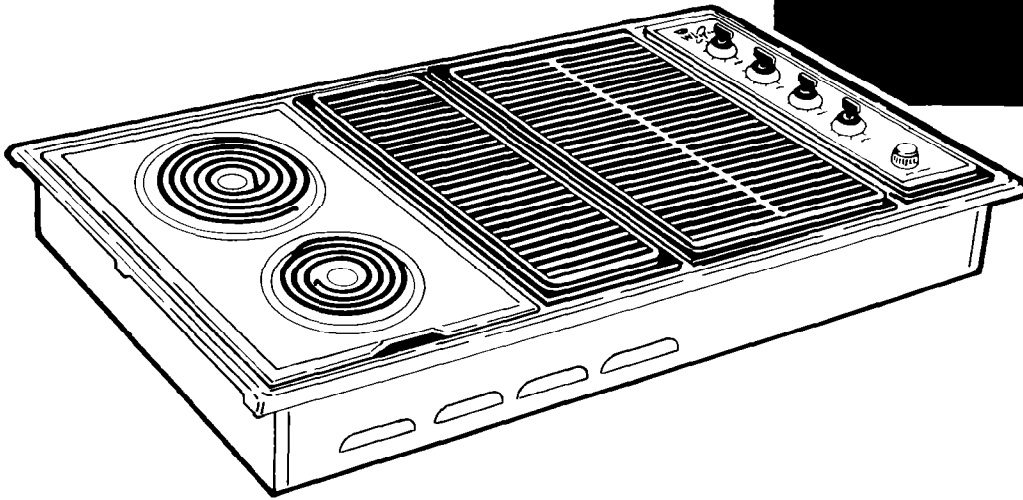

Whirlpool



**ELECTRIC
DOWN DRAFT
SURFACE UNIT**

...ave Ovens, Compactors, Room Air Conditioners, Dehumidifiers, Automatic Washers, Clothes Dryers, Freezers, Refrigerator-Freezers, Ice Makers, Dishwas

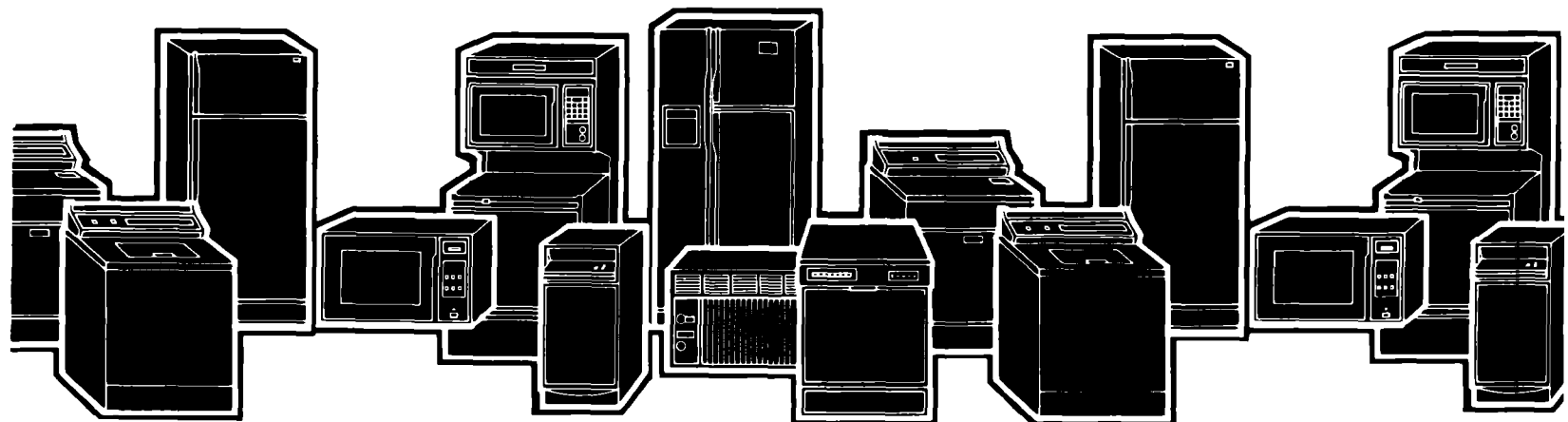

BEFORE YOU BEGIN:

Read the following instructions completely and carefully. If followed, they will simplify the installation job.

IMPORTANT:

Observe all governing codes and ordinances.

SAVE THESE INSTRUCTIONS FOR THE LOCAL ELECTRICAL INSPECTOR'S USE

WIRING DIAGRAM LOCATION:

A wiring diagram for the unit is included in the literature package and a copy is also located at the front of the control cavity (below the control mounting plate).

ELECTRICAL REQUIREMENTS

A. A three-wire or four-wire single phase 120/240 volt 60 Hz AC only electrical supply (or three-wire or four-wire 120/208 volt if specified on nameplate) is required on a separate circuit fused on both sides of the line (time-delay fuse or circuit breaker is recommended). Do **NOT** fuse neutral. The fuse size must not exceed the circuit rating of the appliance specified on the nameplate.

NOTE: Wire sizes and connections must conform with the fuse size and rating of the appliance in accordance with National Electrical Code and local codes and ordinances. Do not use an extension cord.

B. The appliance should be connected to the fused disconnect (or circuit breaker) box through flexible armored or non-metallic sheathed cable. The flexible armored cable extending from the appliance should be connected directly to the junction box. The junction box should be located as shown in Figure 2 on page 3 so that as much slack as possible remains in the cable between the box and the appliance so that it can be moved if servicing is necessary.

C. A suitable strain relief must be provided to attach the power supply cord to the junction box.

1 Unpacking Instructions

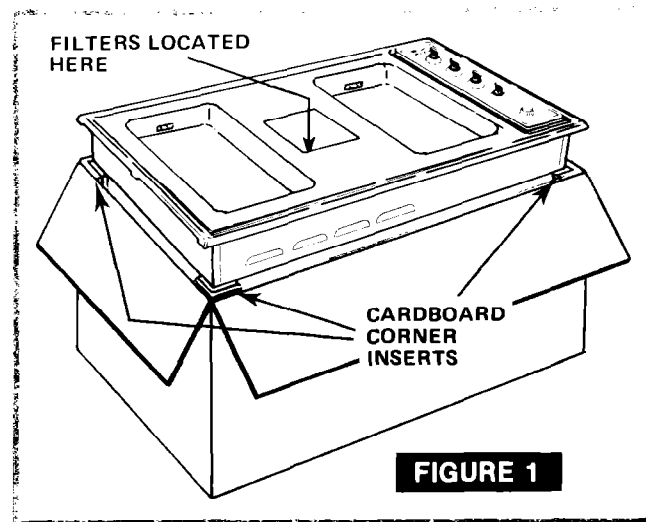

- A. Remove all tape from surface unit, including tape holding filters inside appliance. See Figure 1.
- B. Remove the grill and surface unit module from the unit and place them in a safe place.
- C. Save cardboard corner inserts in shipping carton for use in Step 5.

Installation Instructions

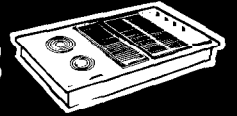

2 Prepare Countertop Cutout Opening

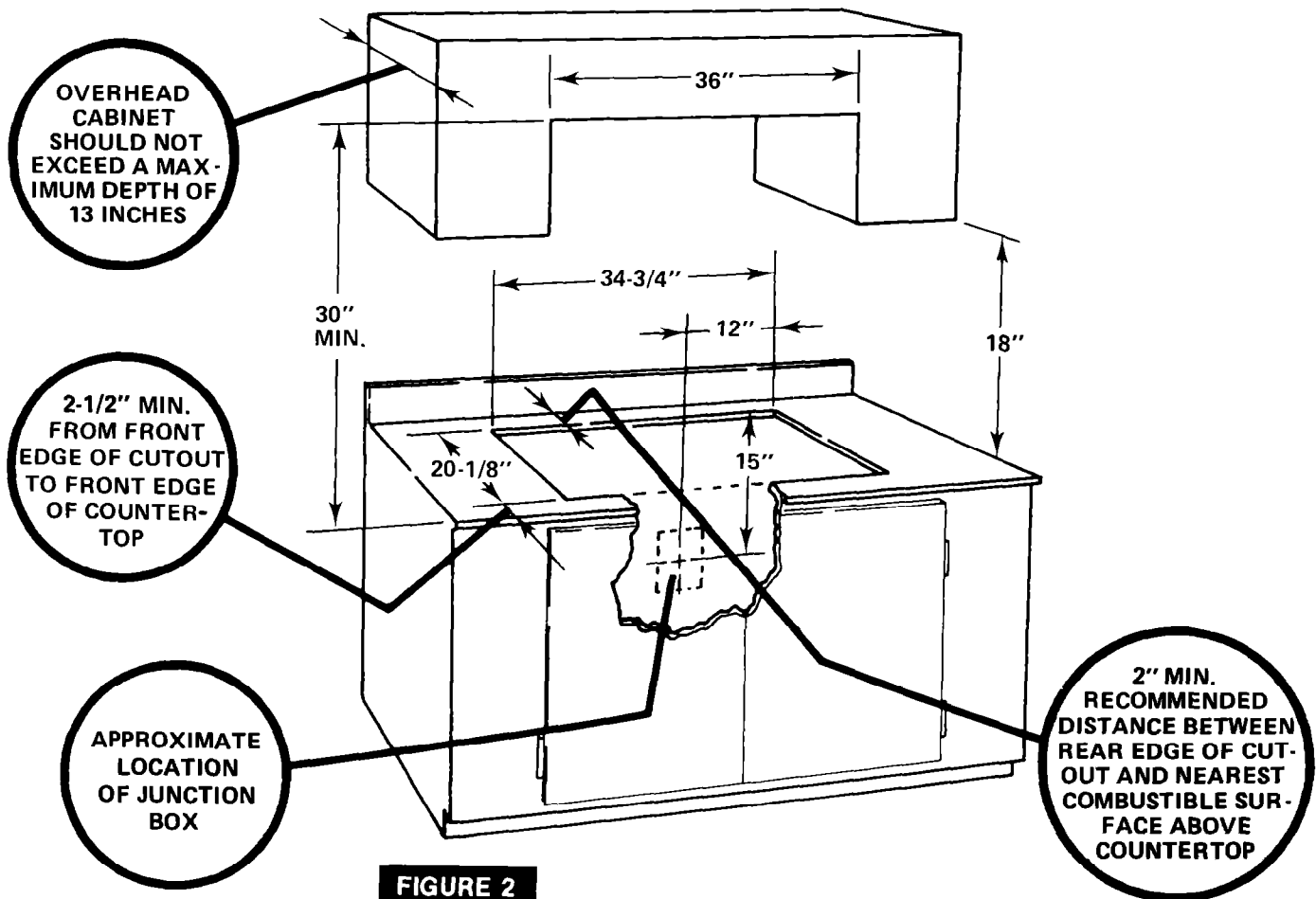

3 Provide Electrical Connection

Install the junction box under the cabinet and run the 120/240 Volt, (or 120/208 Volt if specified on nameplate) AC wire from the main circuit panel. (DO NOT connect the wire to the circuit panel at this time. For basic information, see Electrical Requirements on page 2.

4 Install Ventilation System

WARNING

Downdraft units must always be vented to the outside. Laundry-type (4") wall caps should never be used on the ventilation system.

SPECIAL NOTE:

For shipping reasons, the Blower Housing will not be positioned at the proper angle for venting. To correct, simply grasp the Blower Housing and rotate it to the proper angle needed for your installation application. See Figures 3 & 5.

THROUGH-THE-WALL INSTALLATION (Outside Wall Installation Shown)

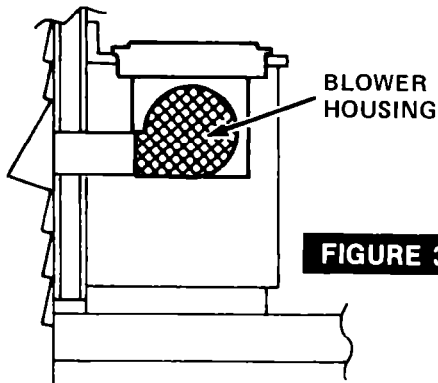

Install directly to outside following dimensions shown below.

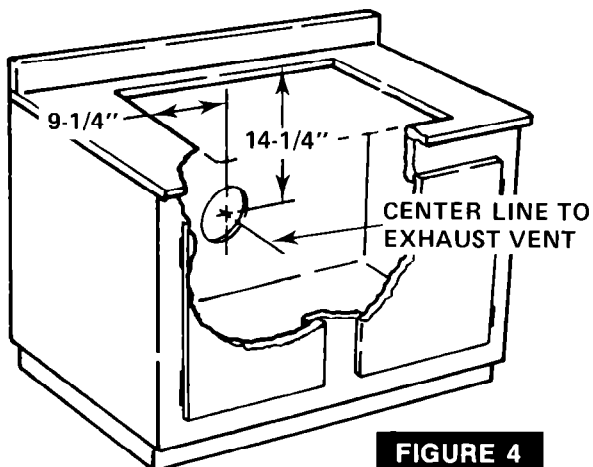

THROUGH-THE-FLOOR INSTALLATION (Peninsula or Island Installation Shown)

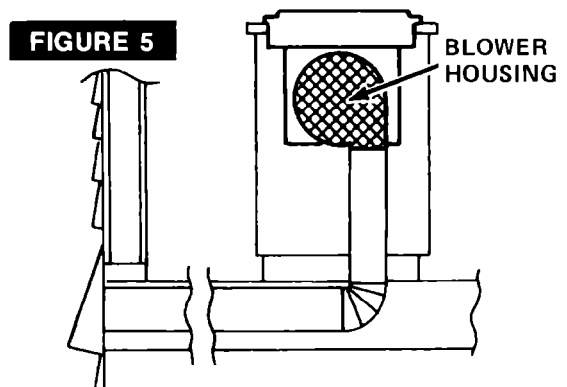

Install between floor joists following dimensions shown below.

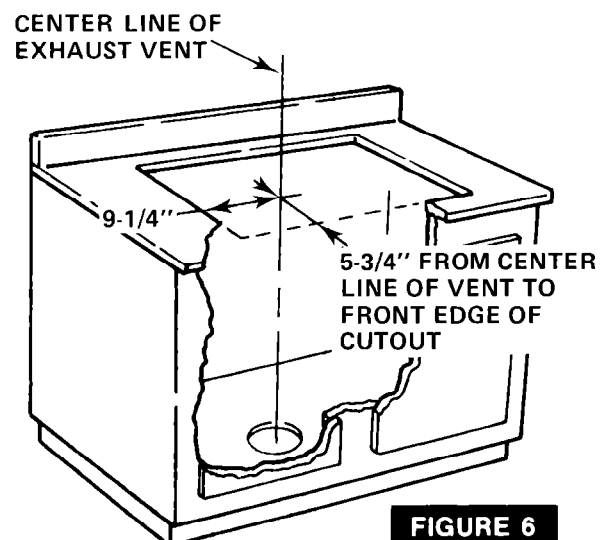

Installation Instructions



PROPER AIR MOVEMENT AND VELOCITY (USE METAL DUCTING ONLY)

Flexible Ducting: Due to the irregular surface of flexible ducting, each foot of the flex duct counts as two feet of straight metal duct. Elbows made of flex ducting would count twice as much as a standard metal elbow.

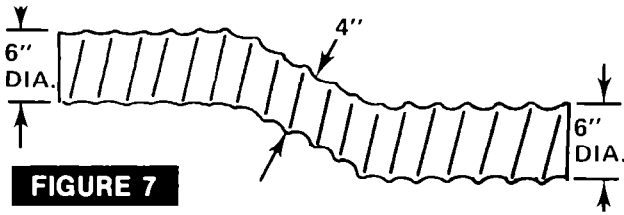

FIGURE 7

Attic Venting: Never vent to either attic or crawl space. Unit must always be ducted to the outside.

Uniform Size: All ducting should be uniform throughout the complete system for proper performance.

Duct Restrictions: Never install two elbow fittings next to each other. This causes unusual air patterns and subsequently interrupts velocity and the end result is poor ventilation.

Sealing joints: All joints in the duct system must be tightly taped to avoid smoke and odor in the home. Also, be sure to caulk thoroughly all joints in floor or wall where duct system goes to the outside.

DUCT LENGTH RECOMMENDATIONS (MAXIMUM)

Use 6" or 3-1/4" x 10" duct on island or peninsula installations. For best performance, it is suggested that no more than three 90° elbows with 6" or 3-1/4" x 10" duct be used.

6" Dia. or 3-1/4" x 10" Duct	
Maximum Calculated Length:	26 feet
When using flexible tubing:	Count each 90° elbow as 10' duct
	Count each foot as 2' of duct

6" System Calculation

(Maximum allowable calculated length 26 feet)

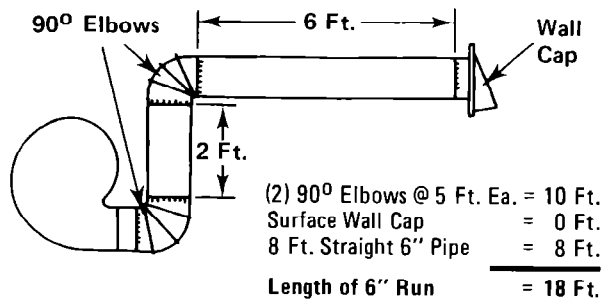

3-1/4" x 10" System Calculation



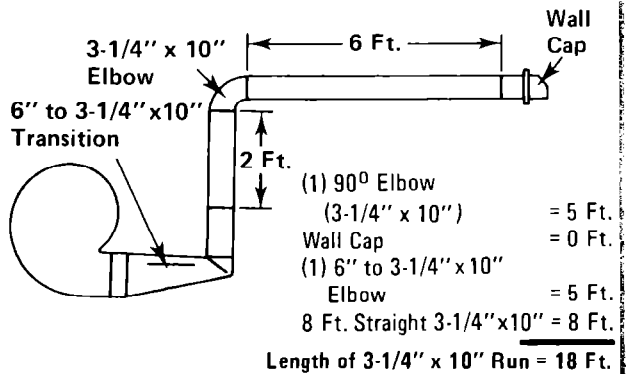



(Maximum allowable calculated length 26 feet)









INDEX OF RECOMMENDED STANDARD FITTINGS

6" Systems: Equivalent length of 6" Duct

3-1/4"x10" Systems: Equivalent length of 3-1/4"x10" Duct

3-1/4"x10" to 6"  Equiv. Length 4.5 Ft.	3-1/4"x10" to 6" 90° Elbow  Equiv. Length 5 Ft.	6" to 3-1/4"x10" 90° Elbow  Equiv. Length 9 Ft.	
90° Elbow  Equiv. Length 5 Ft.	6" to 3-1/4"x10"  Equiv. Length 1 Ft.	45° Elbow  Equiv. Length 2.5 Ft.	6" Wall Cap  Equiv. Length 0 Ft.

3-1/4"x10" to 6"  Equiv. Length 4.5 Ft.	6" to 3-1/4"x10" 90° Elbow  Equiv. Length 6 Ft.	6" to 3-1/4"x10"  Equiv. Length 1 Ft.
3-1/4"x10" 90° Elbow  Equiv. Length 5 Ft.	3-1/4"x10" Flat Elbow  Equiv. Length 12 Ft.	3-1/4"x10" Wall Cap  Equiv. Length 0 Ft.

Note: Never use laundry type wall caps.

5 Install Surface Unit

Place surface unit on its side (resting on unfolded cardboard corner insert from shipping carton). Remove wood skids from bottom, install Venting Adapter to Blower Housing by using the three screws provided. See Figure 8.

NOTE: Because of the length of the Venting Adapter, the Blower Housing should be rotated downward in order to clear the cabinet opening.

Insert unit into countertop opening and tighten hold down bolts at each end of unit as shown in Figure 9.

Install the cooking components in the surface unit. (For the correct installation procedure, see Use and Care Guide in the Literature Package.)

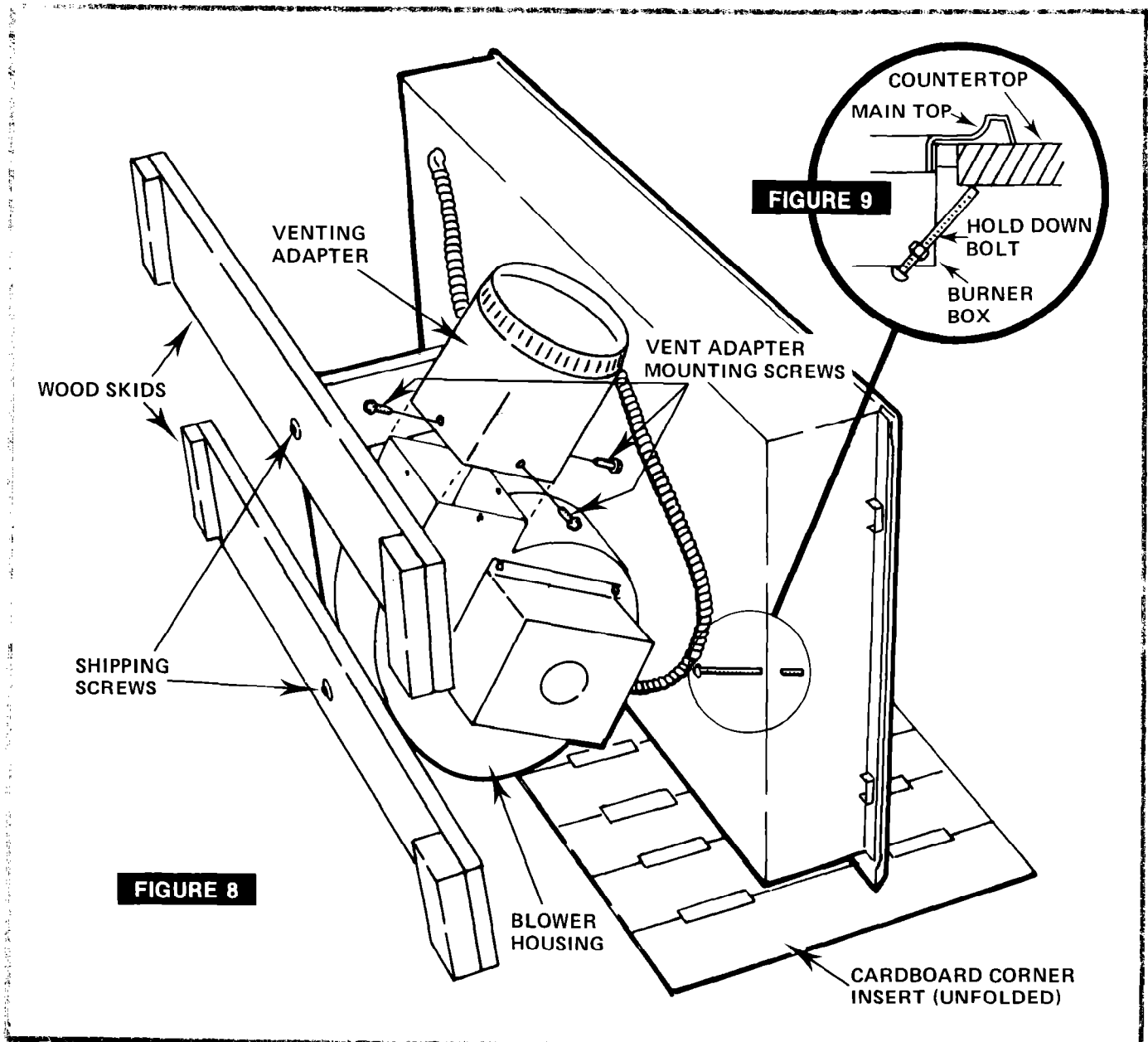



6 Make Electrical Connection

GROUNDING NEUTRAL

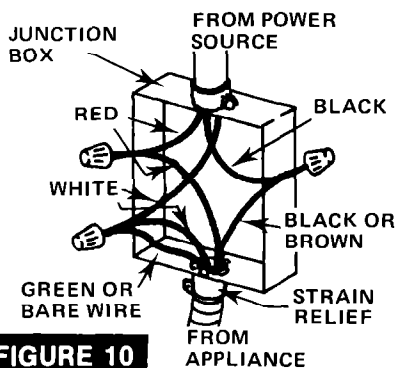

FIGURE 10

Connect the flexible armored cable that extends from the surface unit to the junction box using a suitable strain relief at the point the armored cable enters the junction box. Then make the electrical connection as follows:

It is the personal responsibility and obligation of the customer to contact a qualified installer to assure that the electrical installation is adequate and is in conformance with the National Electrical Code and local code ordinances.

Electrical ground is required on this appliance.

This appliance is equipped with copper lead wires. If connection is made to aluminum house wiring, use only special connectors which are approved for joining copper and aluminum wires in accordance with the National Electrical Code and local codes and ordinances. This appliance is manufactured with a white neutral power supply wire and a frame connected green (or bare) ground wire twisted together.

If local codes permit connection of the frame grounding conductor to the neutral (white) wire, connect the green (or bare wire) and white wire from the supply cable of the appliance together and the neutral (white) wire in the junction box. Connect the remaining wires from the supply cable to the wires in the junction box. See Figure 10.

If local codes DO NOT permit frame grounding to the neutral, separate the white (and green or bare wires) that extend

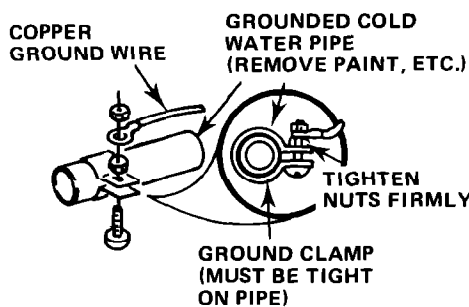

FIGURE 11

UNGROUNDING NEUTRAL

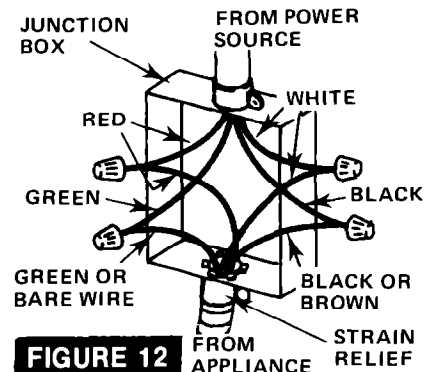

FIGURE 12

out of the end of the supply cable of the appliance. See Figure 12. Connect the white wire from the supply cable to the neutral wire in the junction box. Connect the black (or brown) and red wire from the supply cable, to the corresponding wires in the junction box. The green (or bare) wire must now be used to ground the appliance in accordance with local electrical codes. Connect the green colored copper (or bare) ground wire to a grounded cold water pipe* (see Figure 11) or to the grounded lead in the service panel. **Do not ground to a gas supply pipe.** Do not connect to electric power supply until appliance is permanently grounded. Connect the ground wire before turning on the power. (See Figure 11.)

CAUTION – If connecting to a four-wire electrical system (MOBILE HOME) the appliance frame **MUST NOT** be connected to the neutral wire of the four-wire electrical system. Separate the white (and green or bare wires) that extend out of the end of the supply cable of the appliance. Connect the white, red and black (or brown) wires from the supply cable, to the corresponding wires in the junction box. Connect the green (or bare) wire from the supply cable to the ground wire in the junction box. (See Figure 12)

*Cold water pipe must have metal continuity to electrical ground and not be interrupted by plastic, rubber or other electrically insulating connectors (including water meter or pump) without adding a jumper wire at those connections.

7 Connecting the Vent System

Connect Venting Adapter on bottom of appliance to installed venting system (refer to pages 4 and 5 for venting instructions).

8 Check Operation

When all connections for the appliance have been made, turn each control on to make sure the components are operating correctly. For instructions on operating, cleaning and maintaining this appliance, refer to Use and Care Guide in the Literature Package.



Making your world a little easier.

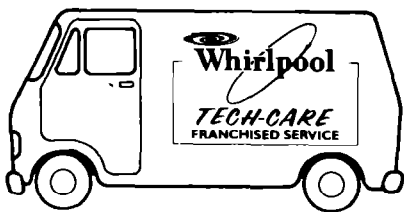

In the event your WHIRLPOOL appliance should need service, call the dealer from whom you purchased the appliance or a WHIRLPOOL franchised TECH-CARE® service company. He is in the Yellow Pages of your telephone directory listed under "Appliances-Household-Major-Service and Repair." You can also obtain his name and number by dialing, free, within the continental United States the Whirlpool COOL-LINE® Service (800) 253-1301. When calling from Michigan, dial (800) 632-2243; from Alaska or Hawaii, dial (800) 253-1121. Dial just as you normally dial long distance. A special operator will tell you the name and number of your nearest Whirlpool TECH-CARE service outlet. During normal working hours, Whirlpool consultants at this same number will also answer any questions about operating or maintaining your appliance not covered in your Use and Care Guide.

Learn the benefits of using TECH-CARE service for maintaining the quality originally built into your WHIRLPOOL appliance.

Part No. 63924/786202

Printed in U.S.A.

Whirlpool Home Appliances, including: Air Conditioners, Automatic Washers, Clothes Dryers, Freezers, Refrigerator-Freezers, Ice Makers, Dishwashers, Built-In Ovens and Surface Units, Ranges, Microwaves

