

Monogram.

Use and Care Guide

for ZDW24

Wine Cooler

*Monogram.*TM

Wine Cooler

Introduction

Your new Monogram wine cooler makes an eloquent statement of style, convenience and kitchen planning flexibility. Whether you chose it for its purity of design or the assiduous attention to detail, you'll find that your Monogram wine cooler's superior blend of form and function will delight you for years to come.

The information on the following pages will help you operate and maintain your wine cooler properly.

If you have any other questions—please call the GE Answer Center® (800.626.2000).

Contents

Appliance Registration	3	Model and Serial Numbers	3
Built-In Dimensions	7	Operating Instructions	5
Care and Cleaning	6	Repair Service.....	3
Consumer Services	10	Reversing the Door Swing.....	9
Features.....	4	Warranty.....	11
Important Phone Numbers.....	10	Questions?	
Installation Requirements	8	Call GE Answer Center®	
Loading Tips and Suggestions.....	5	800.626.2000	

Write down the model and serial numbers.

You'll find them on a label on the lower front frame.

These numbers are also on the Consumer Product Ownership Registration Card that came with your wine cooler. Before sending in this card, please write these numbers here:

Model Number

Serial Number

Use these numbers in any correspondence or service calls concerning your wine cooler.

If you received a damaged wine cooler...

Immediately contact the dealer (or builder) that sold you the wine cooler.

If you need service...

To obtain service, see the Consumer Services page in the back of this guide.

We're proud of our service and want you to be pleased. If for some reason you are not happy with the service you receive, here are three steps to follow for further help.

FIRST, contact the people who serviced your appliance. Explain why you are not pleased. In most cases, this will solve the problem.

NEXT, if you are still not pleased, write all the details—including your phone number—to:

Manager, Consumer Relations
GE Appliances
Appliance Park
Louisville, KY 40225

FINALLY, if your problem is still not resolved, write:

Major Appliance Consumer
Action Program
20 North Wacker Drive
Chicago, IL 60606

FEATURES

Temperature Control

The temperature control is fully adjustable from the low forties to the mid sixties, allowing flexibility for temperature preferences.

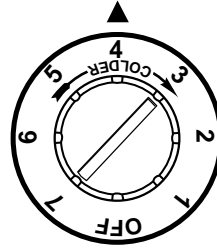

Interior Light and Switch

The interior light makes it easy to view your wine labels and enhances the display of your collection. When the switch is in the OFF position, the light comes on only when the door is opened.

Pull-Out Racks

The bottom five racks pull out so bottles can be more easily added or removed.

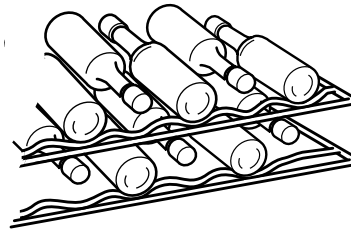

USING YOUR WINE COOLER

Remove Packaging

Before using, be sure all packing materials and tape have been removed. There is a shipping bracket below the handle. Remove the bracket and replace the three screws with the white plug buttons.

If you are discarding an old refrigerator, remove the doors to reduce the danger of children being trapped inside.

Set the Control

The temperature range of the wine cooler is from the low forties to the mid sixties. The middle range is approximately 55°F.

As with any refrigeration product, there is a slight temperature variance at different locations within the cabinet.

The coolest bottles will be in the rear of the four middle shelves.

The bottles on the top two shelves will be 3°F. to 7°F. warmer. This is the warmest location.

The bottles in the front of the middle four shelves will be 1°F. to 4°F. warmer than those at the rear of the shelves.

Position your wine inventory accordingly (i.e. white wines in the cooler zones and red in the warmer zones).

To set the control, turn it to the middle thermostat setting. Once the bottles are loaded, allow at least 48 hours before making any adjustments to the initial setting.

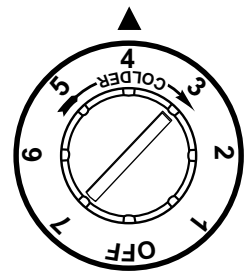

Insert Wine Bottles

The top two racks each hold six bottles, two deep with the necks alternating front to back.

The middle four racks each hold eight bottles, two deep with necks alternating front to back.

The bottom rack holds six bottles and is loaded with necks facing the rear. Tall bottles should not be loaded on the bottom rack because they may prevent the door from closing.

LOADING TIPS AND SUGGESTIONS

- The bottom rack may be removed for storing “jug” wines.
- You may store magnums and other large bottles on the upper right and left positions or on any of the middle racks by removing the rack directly above them.
- The bottles on the top rack, directly under the light, will be exposed to a slightly higher temperature when the light is on. Position your wines accordingly and remember to turn off the light when it is no longer needed.
- Keep wines that you plan to use for everyday drinking and entertaining on the front half of the racks where labels are completely visible. Place wines for aging or longer term storage in the rear.
- Do not allow children to climb, stand or hang on the wine cooler shelves. They could seriously injure themselves and possibly cause damage to the wine cooler.

CARE AND CLEANING

Unplug the wine cooler before cleaning.

Condenser

Be sure that nothing obstructs the required air flow openings in the front of the cabinet.

For best performance, brush or vacuum lint and dirt from the condenser once a year. Unscrew the grille on the bottom front of the cabinet to access the condenser.

Cabinet

The painted cabinet can be washed with mild soap and water. Rinse thoroughly with clear water. Never use abrasive scouring powders.

Interior

Wash the inside with mild soap and water or baking soda and water.

Do not use an abrasive powder, solvent, polish cleaner or undiluted detergent.

Glass Door

Use a glass cleaner or mild soap and water and a soft cloth to clean the glass door. Do not use any abrasive powders.

Door Gasket

The vinyl gasket may be cleaned with mild soap and water, a baking soda solution or a mild scouring powder. Rinse well.

Light Bulb Replacement

Unplug the wine cooler before replacing the light bulb.

The light shield is held in place by three screws. Remove the screws and light shield to remove the light bulb. Replace with the same type bulb—a 15-watt, intermediate base bulb.

In the Event of a Power Failure

If the power fails, open the door as infrequently as possible to maintain the temperature. A gradual rise in temperature should not have any adverse effect on the wine.

If it is extremely hot, you may want to move the wine to the coolest location you can find until power is restored.

Do not store or use gasoline or other flammable vapors and liquids in the vicinity of this or any other appliance.

BUILT-IN DIMENSIONS

The wine cooler can be a free-standing model or can be built in using the cut-out dimensions at right.

When building in the wine cooler, be sure to allow for a full door swing so you have full access to the pull-out racks.

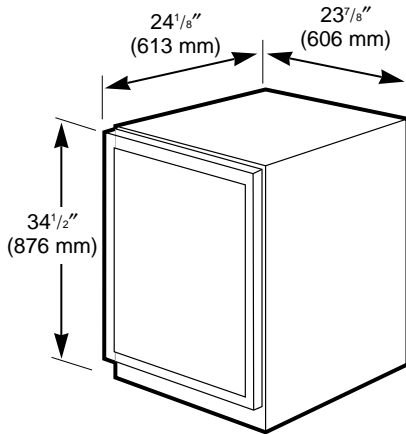

Product dimensions:

Height: 34 1/2" (876 mm)

Width: 23 7/8" (606 mm)

Depth: 24 1/8" (613 mm)

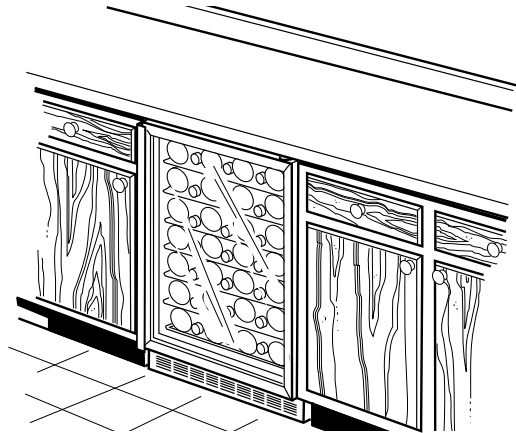

Cut-out dimensions:

Height: 34 1/2–35" (876–889 mm)

Width: 24" (610 mm) minimum

Depth: 24" (610 mm) minimum

INSTALLATION REQUIREMENTS

IMPORTANT...PLEASE READ CAREFULLY

Before it is used, the wine cooler must be properly installed and located as described in this manual.

How to Connect Electricity

For personal safety, this appliance must be properly grounded.

To reduce the possibility of electric shock, the power cord is equipped with a 3-prong (grounding) plug which mates with a standard 3-prong (grounding) wall outlet.

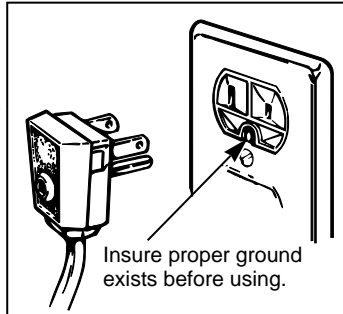

Have the wall outlet and circuit checked by a qualified electrician to make sure the outlet is properly grounded.

If you have only a standard two-prong wall outlet, it is your personal responsibility and obligation to have it replaced with a properly grounded three-prong wall outlet.

DO NOT, UNDER ANY CIRCUMSTANCES, CUT OR REMOVE THE THIRD (GROUND) PRONG FROM THE POWER CORD.

Use of Adapter Plug

Because of potential safety hazards under certain conditions, we strongly recommend against use of an adapter plug. However, if you must use an adapter, where local codes permit, a **TEMPORARY CONNECTION** may be made to a properly grounded 2-prong wall outlet by use of a UL-listed adapter available at most local hardware stores.

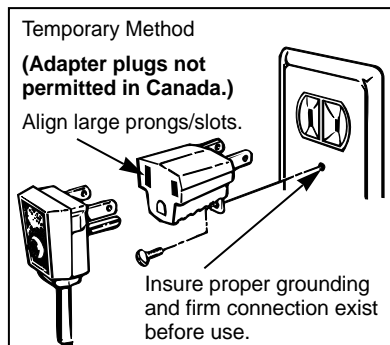

The larger slot in the adapter must be aligned with the larger slot in the wall outlet to provide proper polarity in the connection of the power cord.

Use of an adapter plug will increase the clearance needed for the back of the wine cooler.

CAUTION: Attaching the adapter ground terminal to a wall outlet cover screw does not ground the appliance unless the cover screw is metal, and not insulated, and the wall outlet is grounded through the house wiring. You should have the circuit checked by a qualified electrician to make sure the outlet is properly grounded.

When disconnecting the power cord from the adapter, always hold the adapter in place with one hand while pulling the power cord plug with the other hand. If this is not done, the adapter ground terminal is very likely to break with repeated use.

Should the adapter ground terminal break, DO NOT USE the appliance until a proper ground has again been established.

Use of Extension Cords

Because of potential safety hazards under certain conditions, we strongly recommend against the use of an extension cord.

However, if you must use an extension cord, it is absolutely necessary that it be a UL-listed, 3-wire grounding type appliance extension cord having a grounding type plug and outlet and that the electrical rating of the cord be 15 amperes (minimum) and 120 volts.

Electrical Requirements/Power Cords

- **The wine cooler should always be plugged into its own individual electrical outlet which has a voltage rating that matches the rating plate.** This provides the best performance and also prevents overloading house wiring circuits which could cause a fire hazard from overheated wires.
- Never unplug the wine cooler by pulling on the power cord. Always grip the plug firmly and pull straight out from the outlet.
- Repair or replace immediately all power cords that have become frayed or damaged. Do not use a cord that shows cracks or abrasion damage along its length or at either end.
- When moving the wine cooler, be careful not to damage the power cord.

REVERSING THE DOOR SWING

TO REVERSE THE DOOR

1. Remove the top hinge pin using a 1/8" Allen wrench.
2. Lift the door off the bottom hinge.
3. Replace the hinge pin in the top hinge.
4. Switch the top and bottom hinges and move them to the other side. See illustration.
5. Insert the white plug buttons into the old hinge holes.
6. Unscrew the light trigger from the door bottom and insert the gray plug buttons into the holes on the door.
7. Before turning the door upside down, new holes will need to be drilled for the light trigger. Be careful not to drill down more than 1/2" or you may damage the door glass. Measure 12 1/4" from the right side and make a mark. Measure 3/4" over from the first mark and make a second mark. Measure 11/16" in from the front edge of the door and make a mark. See illustration. This is where the new holes will be drilled using a 5/32" drill bit. Install the light trigger.
8. Remove the top hinge pin.
9. Turn the door upside down and place the door on the bottom hinge pin.
10. Screw the top hinge pin into the door.
11. Remove the old nameplate and stick the new Monogram nameplate on the door using the template included.

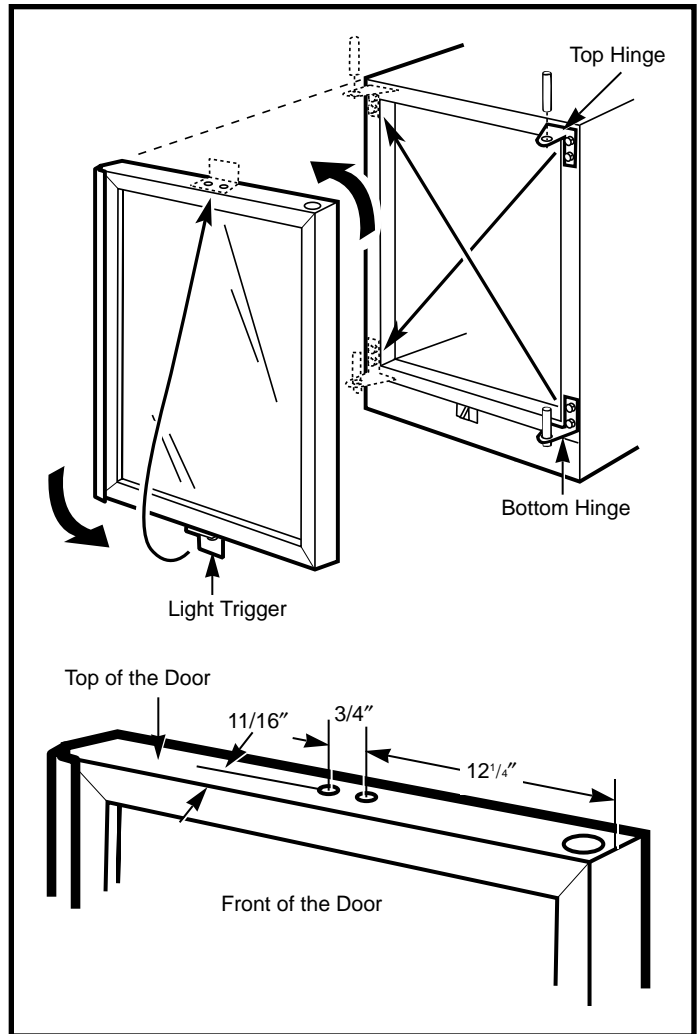

With the purchase of your new Monogram appliance, receive the assurance that if you ever need information or assistance from GE, we'll be there. All you have to do is call—toll-free!

GE Answer Center[®]
800.626.2000

You can call any time. The GE Answer Center[®] service is open 24 hours a day, 7 days a week.

In-Home Repair Service
800-GE-CARES (800-432-2737)

We provide expert repair service, scheduled at a time that's convenient for you.

Our factory-trained technicians know your appliance inside and out—so most repairs can be handled in just one visit.

For Customers With Special Needs...
800.626.2000

GE will provide Braille controls for a variety of Monogram appliances, and a brochure to assist in planning a barrier-free kitchen for persons with limited mobility.

Consumers with impaired hearing or speech who have access to a TDD or a conventional teletypewriter may call 800-TDD-GEAC (800-833-4322) to request information or service.

Service Contracts
800-626-2224

With a service contract GE Consumer Service will still be there after your warranty expires.

With a multiple-year contract, you're assured of future service at today's prices.

Parts and Accessories
800-626-2002

Individuals qualified to service their own appliances can have parts or accessories sent directly to their home.

VISA, MasterCard and Discover cards are accepted.

Further Service

If for some reason you are not happy with the service you receive, here are three steps to follow for further help.

First, contact the people who serviced your appliance. Explain why you are not pleased.

Next, if you are still not pleased, write all the details—including your phone number—to:

Consumer Relations
GE Appliances
Louisville, KY 40225

Finally, if your problem is still not resolved, write:

Major Appliance Consumer Action Program
20 North Wacker Drive
Chicago, IL 60606

YOUR MONOGRAM WINE COOLER WARRANTY*

Staple sales slip or cancelled check here. Proof of original purchase date is needed to obtain service under warranty.

WHAT IS COVERED

FULL ONE-YEAR WARRANTY

For one year from date of original purchase, we will provide, free of charge, **parts and service labor in your home** to repair or replace **any part of the wine cooler** that fails because of a manufacturing defect.

FULL FIVE-YEAR WARRANTY

For five years from date of original purchase, we will provide, free of charge, **parts and service labor in your home** to repair or replace **any part of the sealed refrigerating system** (the compressor, condenser, evaporator and all connecting tubing) that fails because of a manufacturing defect.

This warranty is extended to the original purchaser and any succeeding owner for products purchased for ordinary home use in the 48 mainland states, Hawaii and Washington, D.C. In Alaska the warranty is the same except that it is LIMITED because you must pay to ship the product to the service shop or for the service technician's travel costs to your home.

All warranty service will be provided by our Factory Service Centers or by our authorized Customer Care® servicers during normal working hours.

Should your appliance need service, during warranty period or beyond, call 800-GE-CARES, (800-432-2737).

WHAT IS NOT COVERED

- Service trips to your home to teach you how to use the product.
- Read your Use and Care material.** If you then have any questions about operating the product please contact your dealer or our Consumer Affairs office at the address below, or call, toll free:
- GE Answer Center®
800.626.2000
consumer information service
- Improper installation.

If you have an installation problem, contact your dealer or installer. You are responsible for providing adequate electrical and other connecting facilities.

- Replacement of house fuses or resetting of circuit breakers.
- Failure of the product if it is used for other than its intended purpose or used commercially.
- Damage to product caused by accident, fire, floods or acts of God.

WARRANTOR IS NOT RESPONSIBLE FOR CONSEQUENTIAL DAMAGES.

Some states do not allow the exclusion or limitation of incidental or consequential damages, so the above limitation or exclusion may not apply to you. This warranty gives you specific legal rights, and you may also have other rights which vary from state to state. To know what your legal rights are in your state, consult your local or state consumer affairs office or your state's Attorney General.

Warrantor: General Electric Company

**If further help is needed concerning this warranty, write:
Manager—Consumer Affairs, GE Appliances, Louisville, KY 40225**

Model ZDW24



Monogram™

General Electric Company
Louisville, KY 40225

Pub. No. 49-6862
Part No. 162D7749P001
2-96 CG