

OVEN CIRCUIT WITH CONVECTION MODEL / CIRCUIT DU FOUR AVEC MODELE CONVECTION

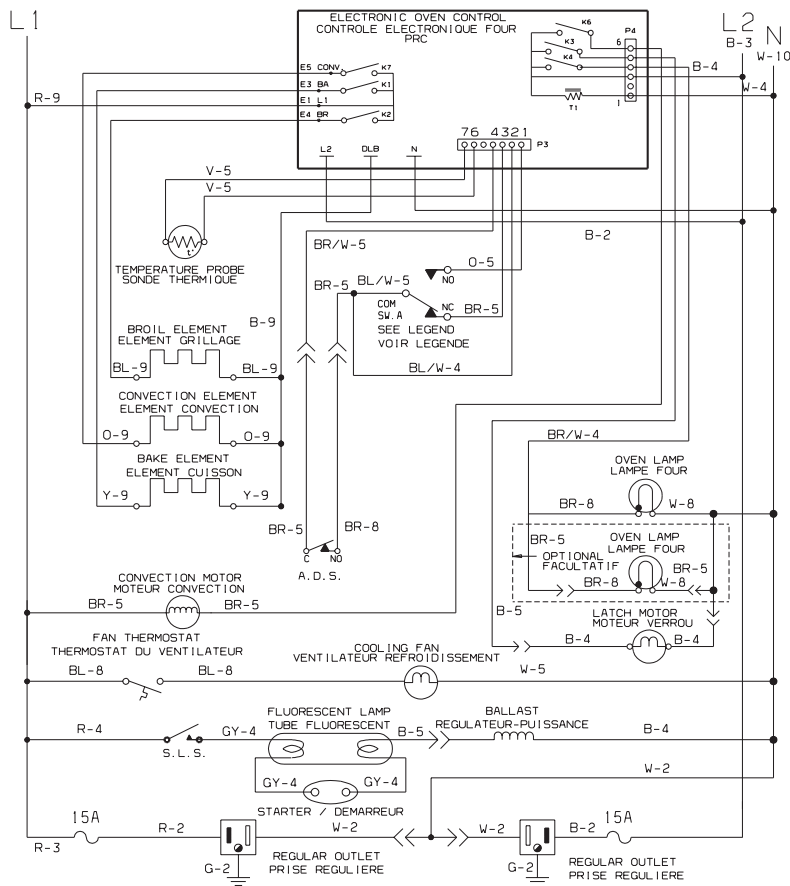

COLORS / COULEURS

B- BLACK / NOIR	G- GREEN / VERT
W- WHITE / BLANC	R- RED / ROUGE
O- ORANGE / ORANGE	Y- YELLOW / JAUNE
BR- BROWN / BRUN	BL- BLUE / BLEU
PK- PINK / ROSE	BR/W- BROWN/WHITE / BRUN/BLANC
V- VIOLET / VIOLET	BL/W- BLUE/WHITE / BLEU/BLANC

CODE STYLE

CODE	GAUGE/CAL.	TEMP. °C	CSA	UL
1	10	150	EXL-150	3321
2	16	125	CL1251	3173
3	16	200	SEW-1	3122
4	18	125	CL1251	3173
5	18	150	EXL-150	3321
6	14	125	CL1251	3173
7	12	125	CL1251	3173
8	18	200	SEW-1	3122
9	16	150	EXL-150	3321
10	14	150	EXL-150	3321

UNIT RATING
ETALONNAGE DES ELEMENTS

RATED VOLTAGE / TENSION: 240 V.		
OVEN ELEMENTS ELEMENTS DU FOUR	WATTS	OHMS
BAKE / CUISSON	3400	16.9
BROIL / GRIL	3000	19.2
CONVECTION / CONVECTION	2500	23.0

OVEN TEMPERATURE
TEMPERATURE DU FOUR

CLEANING CYCLE CYCLE DE NETTOYAGE	860°F ±25°F
DOOR LOCK VERROUILLAGE DE PORTE	550°F ±25°F

OVEN CIRCUIT / CIRCUIT DU FOUR

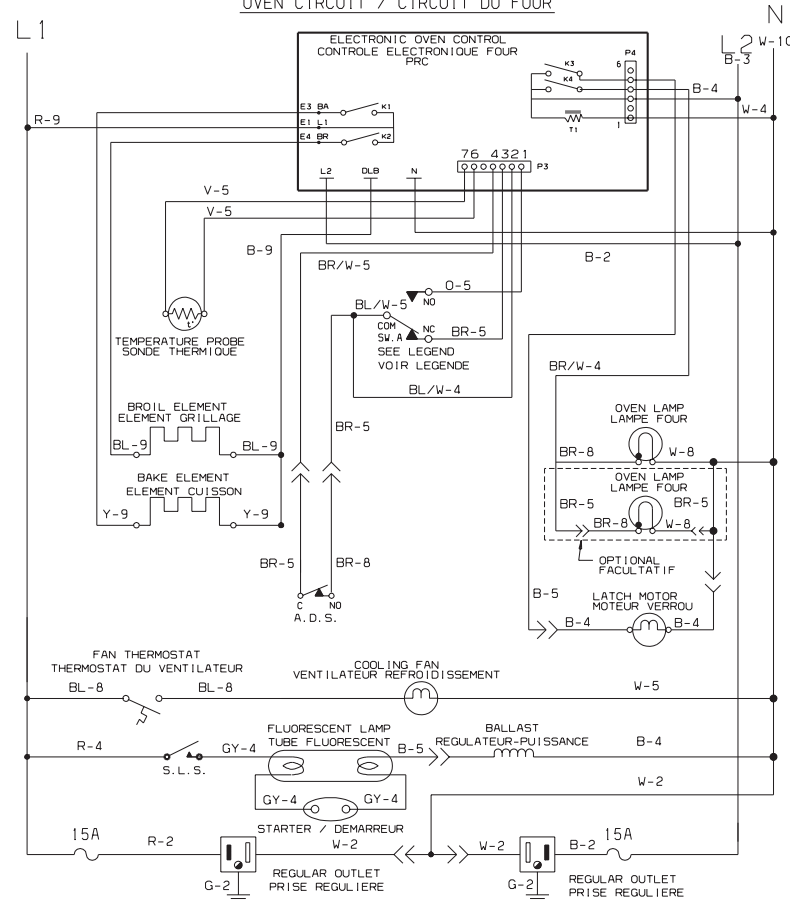

* -----
COMPONENTS SHOWN ARE NOT
NECESSARILY USED ON ALL MODELS.

LES ACCESSOIRES MONTRES ICI,
NE SONT PAS OBLIGATOIREMENT
EMPLOYES SUR TOUS LES MODELES.

CAUTION: DISCONNECT POWER BEFORE SERVICING UNIT.
ATTENTION: COUPEZ L'ALIMENTATION AVANT D'EFFECTUER LA REPARATION.

318046746 REV. A

SURFACE ELEMENTS CIRCUIT / CIRCUIT-ELEMENTS-SURFACE

SMOOTH TOP WITH ONE DOUBLE ELEMENT / VITRIFIEE AVEC UN DOUBLE ELEMENT

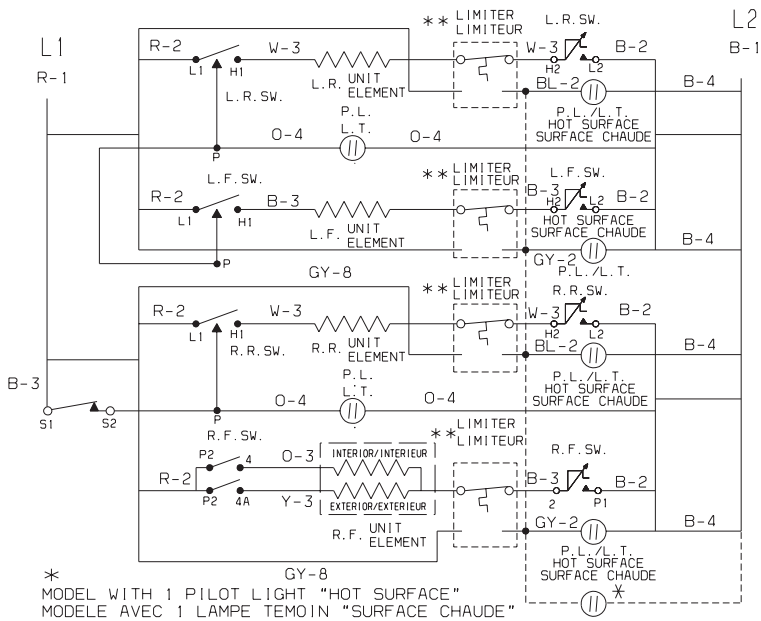

SURFACE ELEMENTS CIRCUIT / CIRCUIT-ELEMENTS SURFACE

COIL ELEMENTS / ELEMENTS SPIRALES

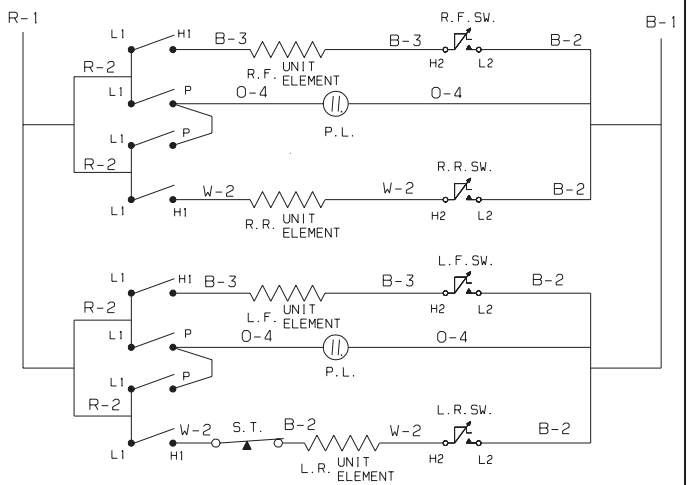

SURFACE ELEMENTS CIRCUIT / CIRCUIT-ELEMENTS-SURFACE

SMOOTH TOP / VITRIFIEE

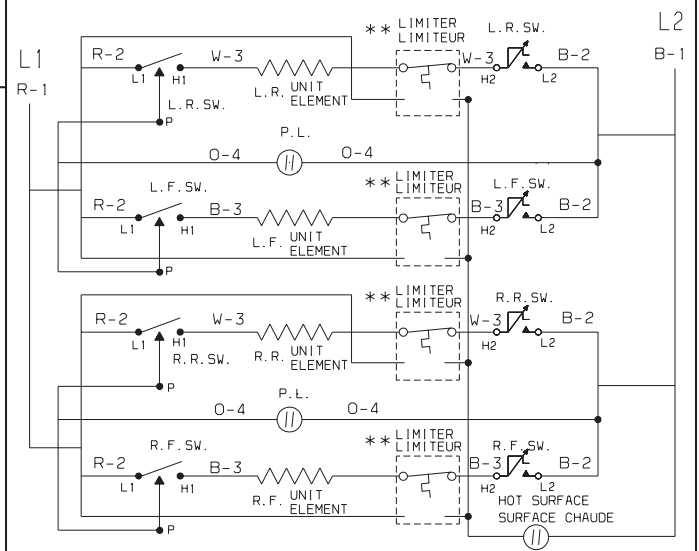

SURFACE ELEMENTS CIRCUIT / CIRCUIT-ELEMENTS-SURFACE

SMOOTH TOP WITH ONE BRIDGE ELEMENT / VITRIFIEE AVEC UN PONT ELEMENT

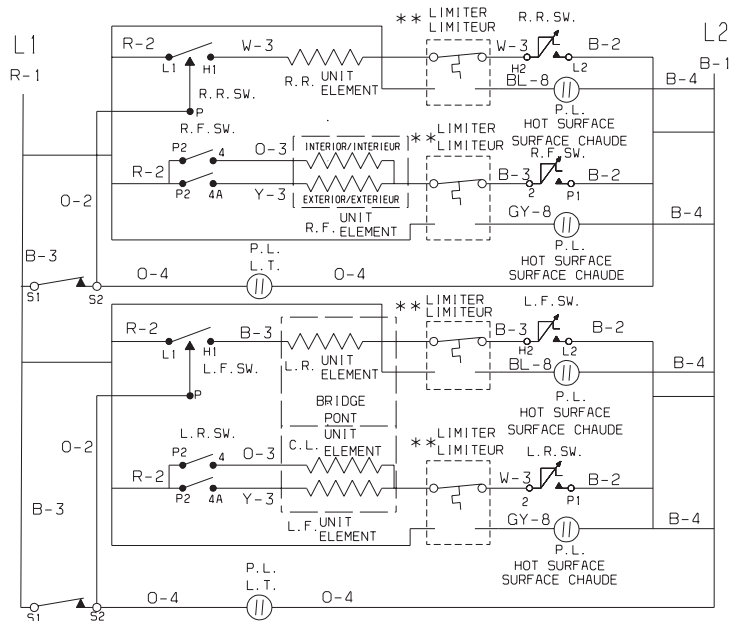

ELEMENTS WARMER ZONE CIRCUIT / CIRCUIT-ELEMENTS-ZONE RECHAUD

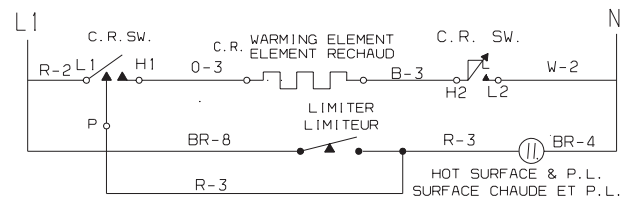

SURFACE ELEMENTS CIRCUIT / CIRCUIT-ELEMENTS-SURFACE

SMOOTH TOP WITH TWO DOUBLE ELEMENT (FRONT) / VITRIFIEE AVEC DEUX DOUBLE ELEMENT (AVANT)

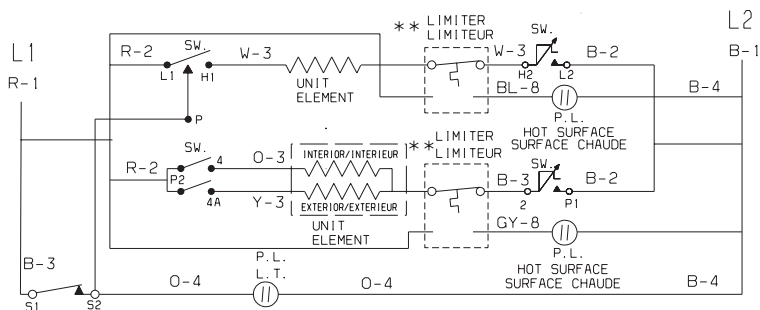

SW. A
MOTOR LATCH SWITCH/
INTER. MOTEUR VERROU

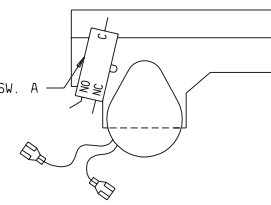

** LIMITEUR/LIMITEUR
CERAMASPEED/EIKA

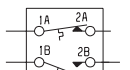

** LIMITEUR/LIMITEUR
E.G.O./A.K.O.

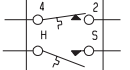

CAUTION:
ATTENTION:

DISCONNECT CURRENT BEFORE REMOVING REAR COVER.
COUPER LE COURANT AVANT D'ENLEVER LE PANNEAU ARRIERE.

REV : A