

ROPER

Nowelle

Downdraft Slide-In Use and Care Manual

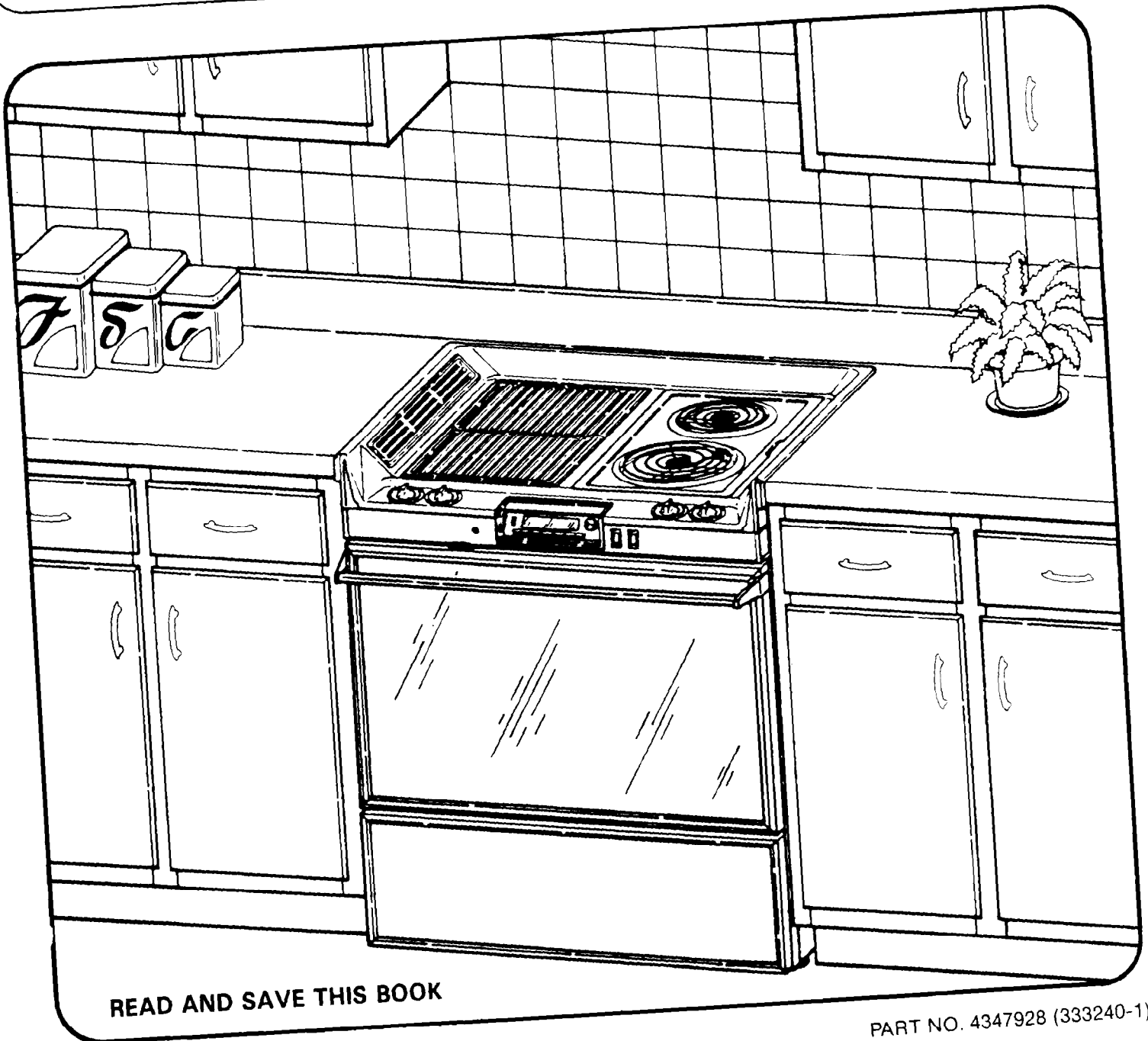

READ AND SAVE THIS BOOK

PART NO. 4347928 (333240-1)

**THIS PAGE
INTENTIONALLY LEFT BLANK**

Record the Model and Serial numbers of your appliance here. You will need them when calling for service or ordering parts. Both numbers are on a metal plate which is fastened to the underside of the unit.

MODEL NO. _____
SERIAL NO. _____
DATE PURCHASED _____

Contents of this Manual

This Owners Manual covers several types of modules for your cooktop. Your appliance will not have all of the features explained in this manual.

SAFETY RULES	2-5	● Cleaning the Griddle	17
USING YOUR MODULAR COOKTOP	6-8	● Griddle Chart	18
● Important Information	6	● Recipes	18,19
● Range Cooktop Features	6	ROTISS/KEBAB MODULE	20,21
● Using Cooktop Controls	7	● Assembly	20
● Cooktop Signal Light	7	● Using the Rotisserie	20
● Using Downdraft Venting	7	● Rotissing Tips	20
● Care of Modules	7	● Shish Kebabing Tips	21
● Cleaning the Modular Cooktop	7, 8	● Cleaning the Module	21
● Cleaning Downdraft Vents	8	● Rotissing Time Chart	21
● Grease Jars	8	USING THE OVEN	22-25
OPEN COIL AND SOLID ELEMENT MODULES	9-12	● Setting Clock and Timer	22
● Inserting a Module	9	● Setting Electronic Range Controls	22
● Using Electric Elements	9	● Oven Light	22
● Using Open Coil Elements	9	● New Oven Odor	22
● Using Solid Elements	9, 10	COOKING HINTS	23-25
● Removing a Module	10	● Preheating	23
● Cleaning the Modules	10, 11	● Using Foil	23
● Energy Saving Tips	11	● Broiling Tips	23
● Choosing Cooktop Cookware	11	● Positioning Broiler Pan	23
● Cookware Chart	12	● Using a Meat Thermometer	24
● Control Setting Guide	12	● Rack and Pan Arrangement	24
● Recipes	12	● Choosing Oven Cookware Chart	24
GRILL MODULE	13-16	● Common Baking Problems and Causes	25
● Inserting the Grill Module	13	OVEN CLEANING AND CARE	25-29
● Using the Grill	13	● Cleaning Chart	25
● Grilling Tips	14	● Self Clean Cycle	26,27
● Removing the Grill Module	14	● Removable Oven Door	28
● Cleaning the Grill Module	14	● Removable Oven Racks	28
● Module Cover	14	● Replacing the Oven Light	29
● Grilling Chart	14	PREVENTING SERVICE CALLS	30,31
● Recipes	15,16	OPTIONAL MODULES AND ACCESSORIES	32
GRIDDLE	17-19	WARRANTY AND MAINTENANCE AGREEMENT	Back Cover
● Inserting the Griddle Module	17		
● Using the Griddle	17		
● Removing the Griddle Module	17		

IMPORTANT INSTRUCTIONS

Read the Safety Rules below and all operating instructions before using this appliance.

GENERAL

Keep this manual for further use.

Be sure your range is properly installed and grounded.

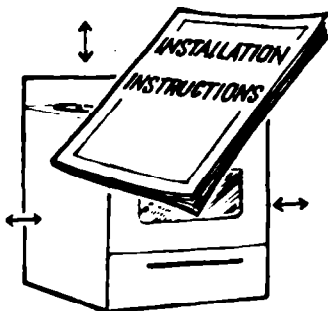

Never try to repair or replace any part of the range unless specifically recommended in this manual. All other servicing should be done by a qualified technician.

Only certain types of glass, glass/ceramic, ceramic, earthenware, or other glazed utensils are suitable for cooktop cooking without breaking due to sudden temperature changes. See page 11 and 12 for proper choice of utensils.

PROTECT YOUR CHILDREN

Teach your children not to play with range controls or climb onto the range. As they become old enough, teach them to use the range safely and correctly.

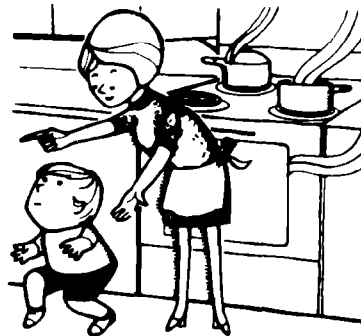

Never leave children alone or unwatched in an area where a range is in use. Children should never be allowed to sit or stand on the cooktop or open oven door. The child's weight on the open door may make the range tip over causing burns or other injury. Never leave the oven door open when the range is unattended.



Caution — Do not store items of interest to children in cabinets above a range. Children climbing on a range to reach items could be seriously injured.



Always turn utensil handles inward, instead of above another cooktop element or over the front of the range, to minimize accidental spillage or burns.



SAFETY

Never use your range for warming or heating a room. Such use can be dangerous as well as damaging to range parts.

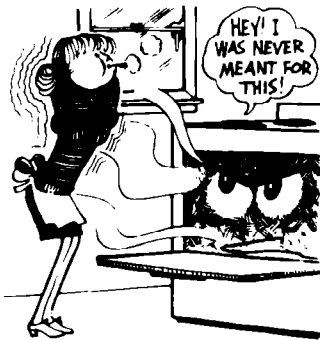

Always use care when opening oven door. Let hot air or steam escape before removing or replacing food.

Always move oven racks while oven is cool. If a rack must be moved while the oven is hot, do not let the pot holder touch the hot heating element in the oven.

Always use dry pot holders when removing pans from the oven or surface units. Moist or damp pot holders can cause steam burns. Do not let a pot holder touch a hot steaming element. Do not use a towel or other bulky cloth.

Never wear loose fitting or hanging clothes while using your range. Such clothes may ignite and cause serious injury.



Never heat unopened food containers. Pressure build-up may make container burst and cause injury.



Make sure reflector pans or drip bowls are in place. If these pans or bowls are not there during cooking, wiring or other parts may be damaged.

Never touch cooktop elements, areas near cooktop elements, oven heating elements or interior surfaces of oven. Heating elements and nearby areas may be hot enough to burn you even though they are dark in color. During and after use, do not let clothing or flammable materials touch heating elements or oven surfaces until they have had time to cool. Other surfaces that may become hot during use are the oven vent duct and the oven door.

Select utensils with flat bottoms large enough to cover the entire cooktop element. This will reduce risk of ignition of clothing from a partially exposed heating element, and improve efficiency.

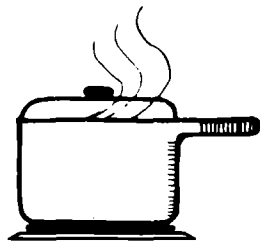

Never soak or immerse removable heating elements in water.

GREASE FIRES

Never leave containers of fat or drippings on or near the range. Never let grease collect on your range. You can help prevent grease fires if you clean up grease and spillovers after each range use.

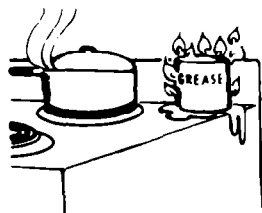

Never try to move a pan of hot fat, especially a deep fat fryer. Wait until the fat has cooled.

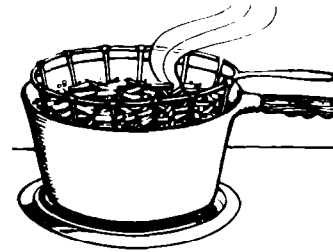

Always keep the appliance area clear and free from combustible materials, gasoline and other flammable vapors and liquids. Never store flammable materials in an oven or near cooktop elements. Flammable items may catch fire and plastic items may melt and ignite.

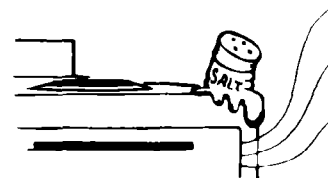
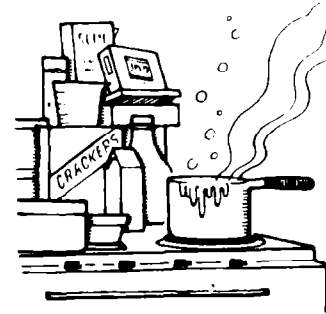

Never leave cooktop elements unwatched at high heat settings. Boilovers cause smoking, and greasy spillovers may catch fire.

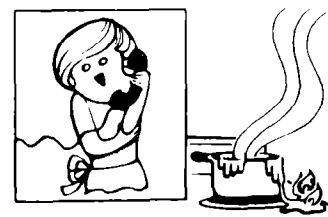

When broiling, always remember to remove the broiler pan from the range and clean it when you are done cooking. If you leave a broiler pan full of grease in the range and later use the oven, you may have a broiler fire.

Never use aluminum foil to line drip bowls or oven bottoms, except as suggested on pages 13, 14 and 23 of this manual. Improper use of these liners may create a fire hazard.

PUTTING OUT A GREASE FIRE

It is a good idea to have a dry chemical, foam or Halon type fire extinguisher where you can easily reach it in case of a cooking fire. A Halon extinguisher will not spoil the food and makes no mess.

Never use water on a grease fire — it will only spread the flames. **Never** pick up a flaming pan. **Instead:**

1. Turn off the heating element.
2. Smother the fire with a tightly fitting pan lid, baking soda or an extinguisher.

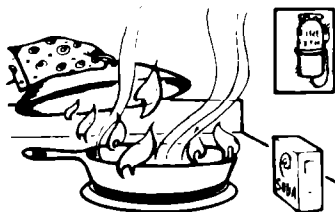

How to put out a liquid grease fire with a fire extinguisher.

1. Stand back 5 or 6 feet.
2. Open the extinguisher.
3. Starting at the flames closest to you, move the extinguisher side to side and work back until all flames are out.

CAUTION: If you bring the extinguisher too close you may blow burning grease all over the cooking area.

SELF-CLEANING OVEN

Always remove the oven racks, the broiler pan and other utensils before a self-cleaning cycle.

Never use any type of commercial oven cleaner or oven liner protective coating in or around any part of your oven. Do not use any type of aerosol product near your range because the chemical that produces the spraying action, may, in the presence of heat, cause metal parts to corrode and could be flammable.



The door gasket is essential for a good seal so care should be taken not to rub, damage, or move the gasket. Clean only with hydrogen peroxide. See page 26.

Clean only range parts listed in this manual. See each module section and pages 25-28 for special cleaning instructions.

Never try to clean other objects in the oven during a self-cleaning cycle unless recommended in the instructions.

VENTILATING FANS

Never let grease accumulate on ventilating hoods or filters — be sure to clean them frequently.

Always turn the ventilating fan off when intentionally flaming foods such as Cherries Jubilee on the open coil or solid element modules. If the fan is operating it may spread the flame.

IMPORTANT INFORMATION

This manual covers all the features on your downdraft range and all optional modules and accessories. Your unit will not have all the features covered in this manual. Your range has a downdraft venting system built in, as

illustrated below and must be vented to the outside. Never try to move the range without first unplugging the blower electrical connector in the lower compartment. See your Installation Guide for more information.

FEATURES

1. Downdraft Vent
2. Grill Module in Place
3. Electronic Range Control
4. Receptacle
5. Open Well
6. Downdraft Vent Switches

7. Downdraft Vent Blower
8. Grease Jars
9. Door Lock/Unlock Handle
10. Cooktop Signal Light
11. Cooktop Controls

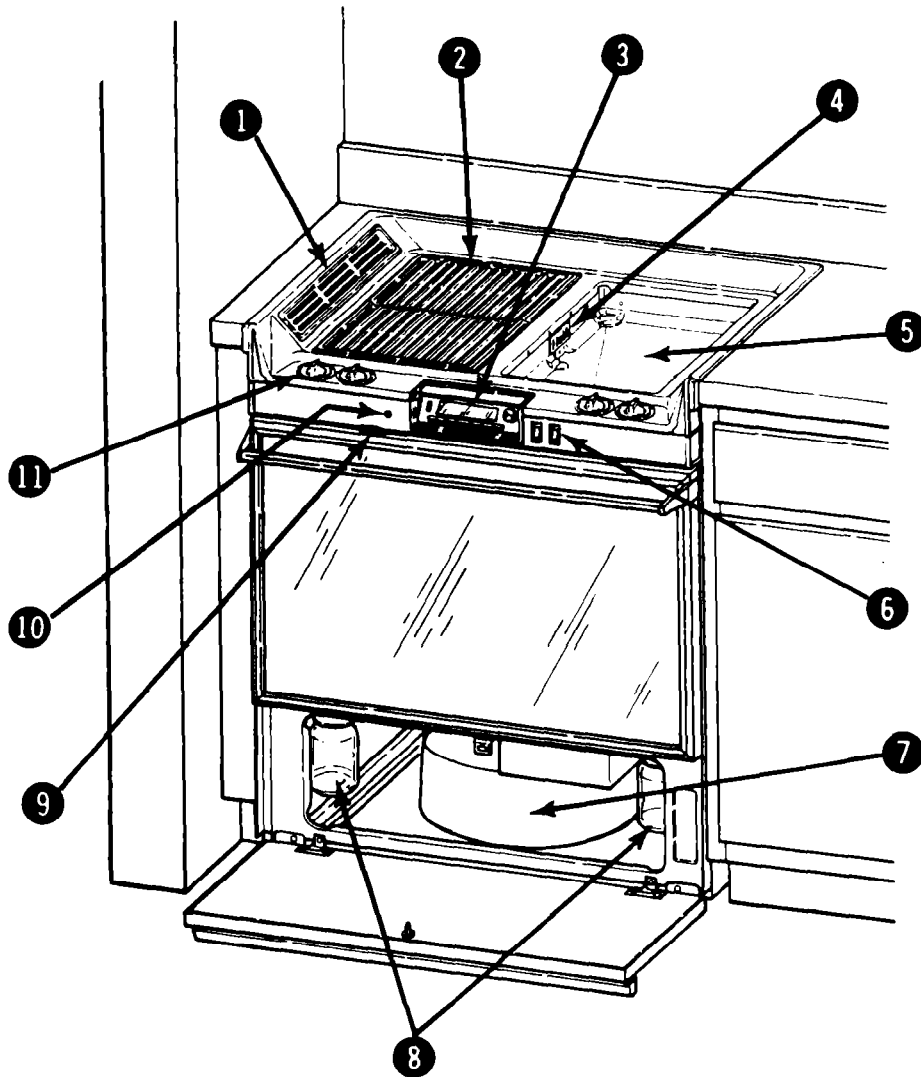

INSERTING AND REMOVING MODULES

Modules can be interchanged quickly and easily. Each module has a plug which fits into a receptacle in the side of the well nearest the center of the cooktop.

Some modules are inserted and removed differently than others. **See each module section for specific instructions for installing and removing that module.**

USING COOKTOP CONTROLS

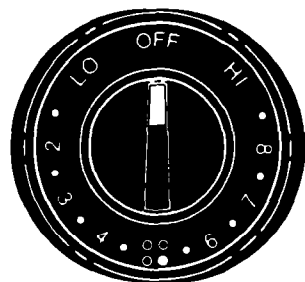

↑
LOCATOR SYMBOL

A locator symbol below each cooktop control knob shows which unit is turned on by that knob.

The knob shown at the left controls the right front unit.

The cooktop controls can be set anywhere between LO and HI for an unlimited number of heat settings. **To turn the control knobs from the OFF position, push the knobs in, then turn in either direction.**

COOKTOP SIGNAL LIGHT

The cooktop signal light on the control panel will glow when any cooktop element is on. It will remind you to turn all the cooktop elements off when you are finished cooking.

USING OPEN COIL ELEMENTS

See the information on using open coil elements on pages 9-11.

USING DOWNDRAFT VENTING

Downdraft ranges have their own venting system within the unit. Cooking vapors and smoke are routed through the vents to the outside.

Whenever you turn any rear cooktop control knob or the oven on, the blower will come on also. Use the HI/LO switch on the front panel to adjust blower speed. When the oven only is on, a LO blower setting is recommended.

Push the bottom portion of the left-hand vent switch to operate the blower, when rear cooktop elements or the oven are not turned on. Pushing the top portion of this switch turns the oven light on. The middle setting on the switch is the OFF position.

RECIPES

Each module section in this manual includes some recipes that may be prepared on that module. These recipes should get you started cooking and give you an idea of the various ways you can use each module.

CARE OF MODULES

Some of the modules must be cured or preconditioned before using them for the first time.

Modules and accessories should be cleaned after each use. The longer soil remains, the harder it is to clean. See each module section in this manual for specific instructions. **Never immerse any module in water.**

When not in the cooktop, modules and accessories should be stored in a clean, dry place. **Always be careful not to drop the modules or they could be damaged.**

CLEANING THE MODULAR COOKTOP

Control Knobs

Pull knobs straight off and wash at the sink with soap and water.

Open Coil Reflector Bowls

See instructions on page 10 for the Open Coil module.

Porcelain Enameled Wells and Cooktop

Porcelain enamel can crack or chip with misuse. It can stain if spillovers of foods with a high acid content (such as tomato or lemon juice) are not cleaned up quickly.

Wash with soap and water. For heavy soil, cover with a damp cloth and let soak 30 minutes or use a scouring pad. Rinse with vinegar and water and dry with a paper towel. **When cleaning porcelain wells, be careful not to get the receptacles wet. Do not try to fill the wells with water.**

Brushed Chrome Cooktop

Wash with soap and water. For heavy soil, cover with a damp cloth and let soak 30 minutes. A chrome cleaner may be used.

To remove fingerprints, apply a little baby oil or cooking oil with a cloth or paper towel. Rub in the same direction as the brush marks on the chrome.

Painted Control Panel

Wash with soap and water. Rinse with vinegar and water and dry with a paper towel. **Do not use scouring pads or abrasive cleaners because they may damage the finish.**

CLEANING DOWNDRAFT VENTS

Downdraft vents and filters should be cleaned frequently — after every use is best. If they are not cleaned frequently, a build-up of grease will reduce efficiency and make cleaning much harder. Also, a really greasy filter may let some grease pass through into the blower system.

To clean:

1. Remove vent grills and lift out aluminum grease filters (see illustration).

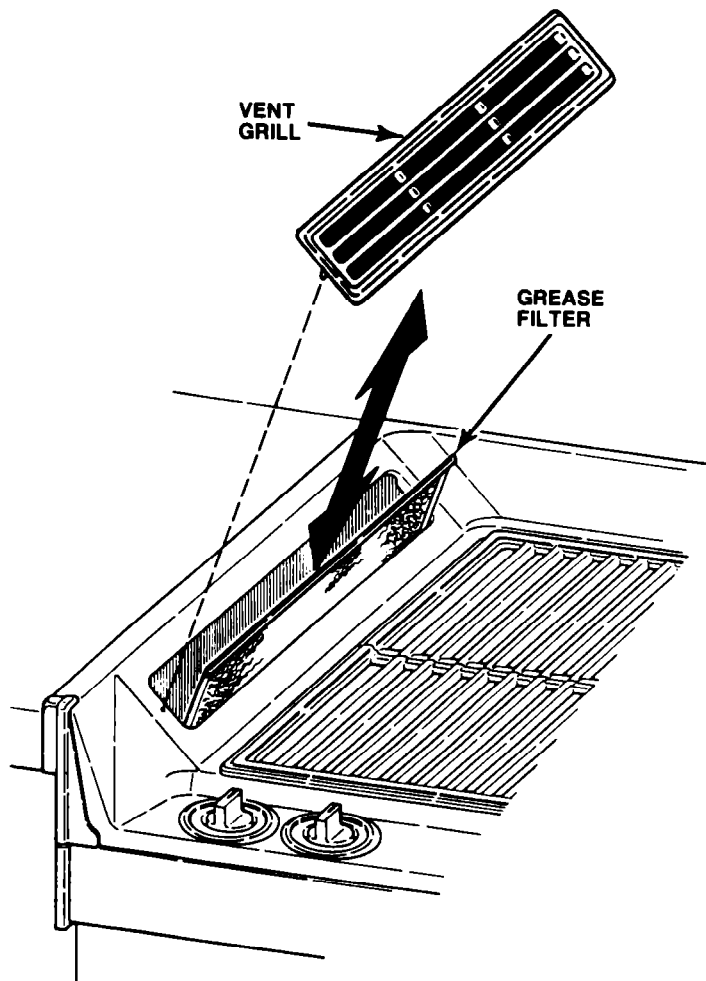

2. Wash grills and filters at the sink in soap and water or in your dishwasher. You can use a small vegetable brush for difficult soil.
3. **Be sure the blower switch is off.** Wash out the vent chambers at each side of the cooktop with a damp soapy cloth or kitchen brush, rinse and dry. **Do not use a sponge because small pieces may break off and be sucked into the blower motor. Do not leave excess liquid in these chambers.**

To replace:

The aluminum grease filters are interchangeable from side to side but they should be placed in the vent chamber as shown in the illustration.

The angled flanges at the top and bottom edges of the filter should face toward the inside of the unit with the top edge slanted outward.

GREASE JARS

Behind the lower panel two grease jars are mounted (one for each well) to catch fat and drippings. To open the lower panel grasp the handle and pull.

The lid of the jar is permanently mounted and connected by a tube to a spout at the front of each well. The jar can be unscrewed from the lid to be emptied and cleaned, or to be replaced. The jar is a standard 1 pint mayonnaise or salad dressing jar. Other glass jars such as 1 pint instant tea, dry creamer and malted milk jars as well as pint or quart canning jars may also fit.

Different foods give different amounts of fat and drippings so you should check the jar each time it is used. If the jar is not emptied or replaced often enough, the fat and drippings may overflow.

INSERTING A MODULE

To insert a module:

1. First, be sure the controls are **OFF** and the unit is cool, clean and dry.
2. Grasping the module firmly, slide it down into the well and fit the plug into the receptacle (see illustration). **Do not hold the opposite side of the module too high or the plug may be damaged.**
3. Use the finger grip in the side of the module opposite the plug to lower the module completely into the well (flush with the cooktop). **Be careful not to pinch your fingers.**

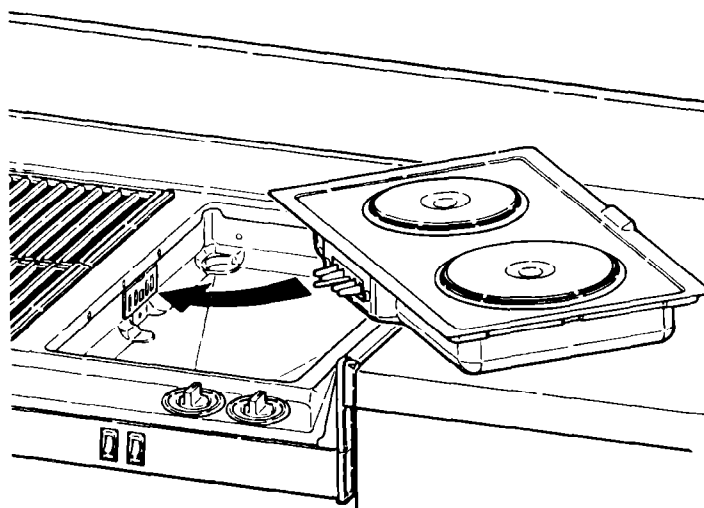

USING ELECTRIC ELEMENTS

You should consider heat up and cool down times for the elements when determining cooking times. Heat up and cool down times depend on initial temperature settings, the type of cookware used and amount of food being cooked.

Start cooking at a higher setting to heat the element faster, then turn to a lower setting to finish cooking. **Remember, cooking continues after the element is turned off, so train yourself to turn the heat down or off before cooking is finished.**

See the chart on page 12 for suggested control settings.

USING OPEN COIL ELEMENTS

When using open coil elements, it is important to use the correct size and style pan. See **Choosing Cookware** on pages 11 and 12.

Never leave an empty pan on a hot open coil element. This can damage the module, reflector bowl, and element as well as the pan.



Never line the reflector bowls under open coil elements with aluminum foil. Foil can block normal heat flow, and damage the unit.

USING SOLID ELEMENTS



Before using the solid elements for the first time, you must cure them to harden the protective coating for long life. If the elements are not cured properly, the coating can stick to your pan and remove some of the finish on the element. See instructions below.

To properly cure the solid elements, heat each element at Hi setting, **without a pan on the element.**

There will be some non-toxic smoke and odor and the rings around the elements will change to a gold color. All this is normal. Use your venting system to minimize the smoke and odor. Heat the elements for 3 to 5 minutes — until the smoking stops.

Solid cast iron elements look very different from the traditional open coil elements you are used to. The heating coils in the solid elements are permanently sealed and protected under the casting for long life. It is very important to use the correct cookware on the solid element.

In order to obtain good performance from your solid element your cookware must be perfectly flat on the bottom and be of a heavy gauge material. If your current cookware has been exposed to mild overheating it may be slightly warped and unable to perform efficiently on a solid element. See **Choosing Cookware** on pages 11 and 12 for more information.

Because the solid element is a flat, heavy casting, heat distribution is very even. When used with a correct (flat-bottomed) pan, the solid element provides good heat transfer with no hot spots or scorching.

Since solid elements transfer heat so evenly and well, they do not need to get "red hot" to cook properly. Each element has a built-in "temperature sensor" to protect the element and your pan from excessive (damaging) heat. If the element is left turned on without a pan, or if a pan boils dry, the sensor will detect the excess heat build-up and reduce power to the element. If your cookware has become warped from overheating in the past and there is space between the element and some parts of the pan bottom, this sensor may detect excessive temperatures and automatically turn the element down.

REMOVING A MODULE

To remove a module:

1. First, be sure the controls are **OFF** and the unit is cool.
2. Using the finger grip at the side of the module, raise the module enough so you can grasp it firmly.
3. Raise the module just enough to clear the cooktop.
4. Pull the module away from the receptacle.

CLEANING THE MODULES

Open Coil Elements

The open coil elements can be unplugged and the reflector bowls removed for cleaning.

Be sure the cooktop unit control knobs are turned off and elements are cool before you remove or replace a cooktop element.

To remove:

1. Grasp element, tilt it upward slightly to clear the reflector bowl, then pull away from the receptacle. **The element will not sit level when replaced if it is forced too far upward when removed.**
2. Lift out the reflector bowl.

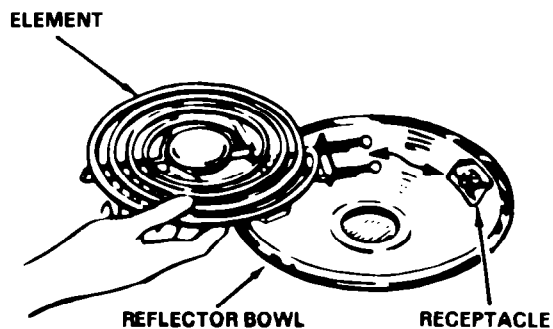

Do not put the element into water. It cleans itself when heated during normal use. To remove any charred soil, clean with a dry, stiff brush when elements have cooled. **Never use steel wool or metal scouring pads because they may damage the outer casing of the element.**

Wash the reflector bowls with soap and water after each spillover. Soak stubborn stains with an ammonia soaked paper towel, then rub gently with a non-metal scouring pad. If spills go below the reflector bowls, you can clean inside the module with a well wrung out soapy cloth.

To replace:

1. Replace the reflector bowl. Be sure the receptacle is showing in the bowl opening.
2. Slide the plug of the element firmly into the receptacle and lower the element into place.

Important: Never operate an open coil element without the reflector bowl in place. This can cause scorching of the module, burning of wiring insulation and loss of energy.

Solid Elements

Solid elements are easy to clean because the element is raised above the cooktop and sealed to it. Food spills can not flow under the pan or the element. Spills stay on the cooktop where they cool and are easy to wipe up.

Be sure the controls are off and the elements are cool before cleaning. Since the elements cool slowly and do not glow red as open coil elements do when they are hot, you should be careful not to get burned when cleaning.

The trim rings around the elements are stainless steel and may be cleaned with a scouring pad or a stainless steel cleaner.

When cleaning solid elements:

- use the mildest cleaning procedure that will do the job
- rub in the direction of the circular ridges
- rinse completely and wipe dry
- **turn elements on to dry completely and prevent rust**

The solid elements can be cleaned with scouring powder or a scouring pad the same as your cast iron skillet. The red dot in the center of each element can be removed by scouring. The dot is for factory identification only and removing this dot will not affect use or durability of the element.

Because the elements are cast iron, they should be kept dry to prevent rust. Be sure the bottom of your pan is dry before you put it on the element. After cleaning the elements, turn them on a few minutes to completely dry them.

After the element has been cleaned, heated to dry it, and cooled, you may wish to use a paper towel to apply a small amount of **salt-free** cooking oil. Use a clean paper towel to remove any excess oil.

It is normal for cast iron to lose its luster as it ages and this will not affect performance or durability of the element. Oiling the elements from time to time will keep them looking nicer and help protect them from rust. Expect a little smoking the next time the elements are turned on.

You can also buy products (such as EGO Electrol or Rutland Paste) to restore appearance of the solid element. Follow manufacturers instructions.

ENERGY SAVING TIPS

- Check the Cookware Chart on page 12 to see which type of cookware is best for each type of cooking you do.
- **Pan bottoms must touch the entire element in order to absorb the full heat output. An undersized or warped pan will expose a portion of the element and the uncovered part will waste heat and energy.**
- When possible, thaw frozen foods before cooking, cook with the minimum amount of water and use a pan with a tightly fitting lid.
- Put pans on the cooktop elements before the heat is turned on, so you will not waste heat.
- Be sure to watch foods when heating them quickly on HI. As soon as the food reaches the cooking temperature, reduce the heat to the lowest setting that will keep it cooking.
- Turn the element off a short time before cooking is done, to use the remaining heat to finish cooking and keep food warm before serving.

CHOOSING COOKTOP COOKWARE

When using open coil and solid elements, it is very important that your cookware:

- has flat bottoms and straight sides
- has lightweight handles that do not tilt the pans
- is the same size or slightly larger than the element

CORRECT



**Pan Bottom Flat / Pan Sits Level
Pan Covers Entire Element**

WRONG

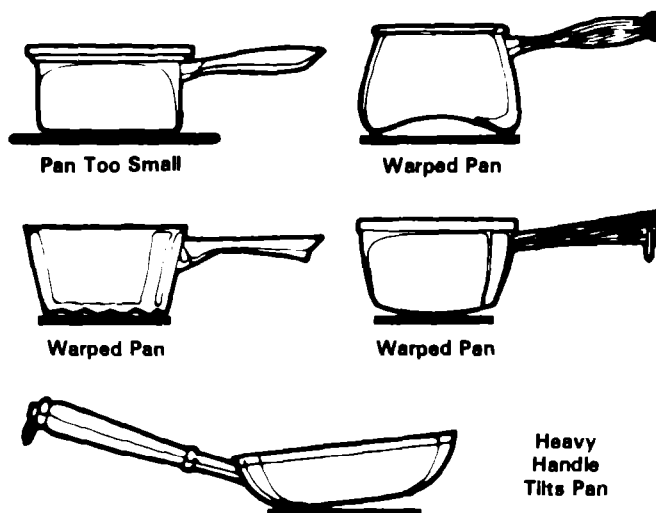

Heat can not transfer properly from the element to the pan if the pan bottom is only **near** the element — the pan and element should **actually touch** each other.

Many pans have a slight depression in the center of the pan bottom. Some "club" type cookware has circular ridges in the pan bottom. Many older pans have become warped from overheating in the past. None of these pans will give top performance on any type of electric cooking element because they do not make **contact** with the entire element. Also read the information about using solid elements on page 9.

To check your pans for flat bottoms, place the edge of a ruler against the bottom of the pan. Rotate the ruler a full 360° around the pan bottom (see illustration). No light should be visible between the ruler and the pan bottom.

If you decide to buy new pans, it would be a good idea to take a ruler along when you shop because some pans are made with central depressions in the bottom which are not very obvious.

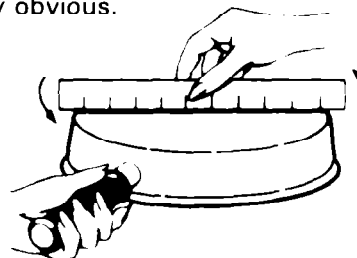

- Q. Can I use special cooking equipment, like an oriental wok, on my open coil or solid elements?**
- A. Some oriental woks have support rings that prevent the utensil from touching the entire element and also block free air flow around the element. The concentration (trapping) of high heat around the element may damage the module. You should not use utensils which extend below the top of the element or utensils which do not touch all of the element.**

COOKWARE CHART

COOKWARE	COOKING NOTES
Aluminum	Spreads heat quickly and evenly. Best for frying, braising and pot roasts.
Cast Iron	Slow to change temperature and holds heat. Good for browning, frying and stewing.
Copper, Tin-lined	Quick to change temperature. Great for gourmet cooking, wine sauces and egg cookery. Tin-lining will wear thin with use and must be retinned to avoid a poisonous reaction between the copper, the heat and the food.
Glass Ceramic	Slow to change temperature. Best for long, low heat cooking with a liquid.
Porcelain Enamel	Porcelain enamel over steel is long lasting, stain and scratch resistant. How well it heats depends upon the type of steel used. Best for cooking soups and other liquids.
Stainless Steel	Usually combined with other metals such as aluminum, copper or carbon steel. These other metals make the cookware heat more quickly while the stainless steel makes it strong and long lasting. Best for frying, sauces, soups, vegetables and egg cooking.

CONTROL SETTING GUIDE

Type of Cooking	Food	Setting to start cooking	Setting to finish cooking
BOILING	Macaroni Products, Pressure Cooking, Steaming	Hi Hi	4-6 4-5
BRAISING, BROWNING OR FRICASSEEING	Meats	4-5	1-3
FRYING	Bacon, Meats Eggs Deep Fat	4-6 Hi 5-6	5-6 2-3 7-8
SIMMERING	Eggs Vegetables Gravies Stews	7 Hi 3-5 Hi	2-3 1-2 2-4 3-4
MELTING	Butter, Cheese, Chocolate	Lo-2	Lo-2

Barbecue Sauce

- 1/2 cup catsup
- 1/4 cup brown sugar
- 1/4 cup oil
- 1/4 cup vinegar
- 2 tablespoons finely chopped onion
- 1 tablespoon Worcestershire sauce
- 1/4 teaspoon dry mustard

1. Heat all ingredients to boiling over medium heat, stirring constantly.
2. Reduce heat and simmer 30 minutes, stirring occasionally.
3. Use sauce on beef, pork or chicken.

Makes 1-1/4 cups

Apricot Baste

- 1 can (8-3/4 oz.) apricots, undrained
- 1/4 cup catsup
- 3 tablespoons lemon juice
- 2 tablespoons salad oil or melted butter
- 1/2 teaspoon salt
- 1/4 teaspoon liquid smoke
- 1/8 teaspoon grated lemon peel

1. Puree apricots and liquid.
2. Combine all ingredients in saucepan.
3. Simmer for 10 to 15 minutes.
4. Use sauce on pork and poultry.

Makes 1-1/2 cups

INSERTING THE GRILL MODULE

To insert the grill:

1. Be sure the controls are **OFF**.
2. Place the two reflector plates in the well as shown in the illustration below.
3. Grasp the grill element with both hands near the plug. Keeping the element as nearly horizontal as possible, push the plug firmly into the receptacle to ensure complete contact (see illustration below).

The element should lie flat and rest on the ridges of the reflector plates.

4. Place the two grill grids into the opening in the cooktop over the grill element.

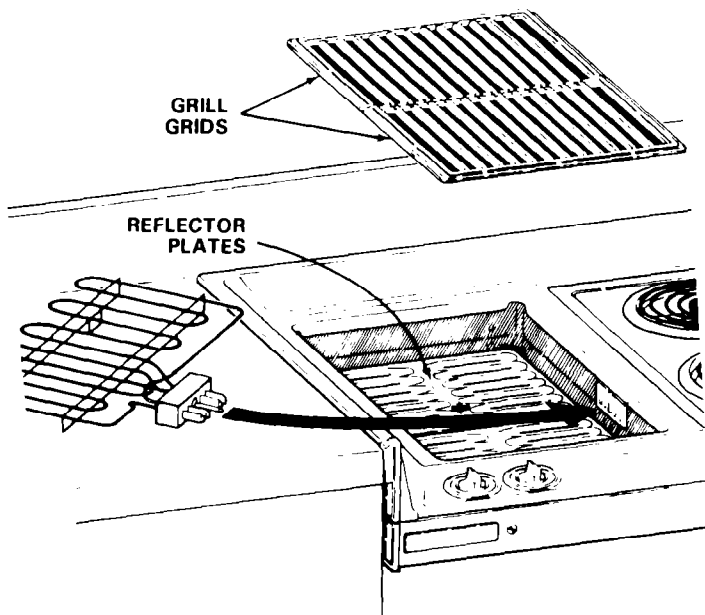

USING THE GRILL

The non-stick grill grids must be preconditioned before using them for the first time. To precondition, wash them in soap and water and dry. Then use a paper towel to apply a small amount of cooking oil to the grids. Remove excess oil with a clean paper towel.

Use the grill for preparing meals with the appearance and flavor of commercially char-broiled meats. The grill must be very hot for this type of cooking and smoke and spatter is to be expected. **Be sure to use your venting system when grilling to help minimize smoke.**

The grill must be preheated to get the grill components hot enough to reflect the heat and to sear the meat to seal in the juices. Preheat the grill on HI for 5 to 10 minutes, then turn back to the recommended setting. See the grilling chart on page 15.

The grill element is divided so the front and rear sections are controlled separately. You can heat both sections to the same temperature for cooking large

amounts of the same food, or you can vary the temperatures for cooking two different foods. Also, you can save energy when cooking small amounts, by turning only one section on and leaving the other off entirely. Remember that the venting system is only automatically turned on when you use the rear controls. If you are using the front portion of the grill only, turn the blower on with the switch on the control panel.

When preparing meats for cooking, be sure to trim excess fat to avoid flame-up during grilling. If excess fat drips onto the grill element, it may catch fire and burn a short time (flame-up). Some flame-ups can be expected with high fat foods. Although this adds a smoky flavor, too much flame-up will cause excessive burning or charring.



NEVER LEAVE THE KITCHEN while grilling meats or other juicy foods. Fats and juices drip on the hot grill element and may cause flame-ups. When grilling you should always be present to control flame-ups so they do not get out of hand.

If you have a bad flame-up and there is danger of the fire spreading, take the following steps immediately:

1. Turn the grill controls to **OFF**.
2. Turn the blower **ON** with the ON/OFF switch on the control panel.
3. Use a long-handled utensil to remove the food from the grill. **Be careful not to get burned.**

The fire should start to go out. If it does not, smother the flames by covering the entire grill module. To do this you can use a large cookie sheet, the lid from a large roasting pan, the griddle or the module cover. **Never use water on a grease fire.**

Check the Safety Rules about grease fires on page 5.



Never try to use charcoal or flavored wood chips in the well under the grill grids. Use of charcoal indoors without proper ventilation produces carbon monoxide that can be fatal. Also, burning charcoal in the well will permanently damage the porcelain coating in the well.

Never line the entire grill grid or the porcelain enameled well with aluminum foil. Doing so may block drainage of grease, cause excessive smoking or fire or damage the unit.

Your new grill module is more versatile than you may realize. Whole-meal cooking can be done on the grill by cooking vegetables and warming bread or sandwiches in heavy-duty aluminum foil or using a small aluminum pan covered with foil.

The recipes in this section will get you started grilling. When you feel ready to experiment, there are several good barbeque cookbooks available at your local bookstore full of recipes that can be easily adapted to your grill module.

GRILLING TIPS

- Never use pots or pans on the grill. Heat could become trapped beneath, resulting in damage to the grill grates or the grill grate finish.
- Pieces of food which lie fairly flat and are no more than 2" thick, such as steaks, chops, hamburger, fish and chicken pieces, are best for grilling. If grilling larger foods or cooking to the well done stage, use a tent of aluminum foil to cover the food to trap and reflect heat and aid cooking.
- Score the fat on the edges of the meat to prevent curling while cooking. Do not cut into the meat itself or juices will be lost and the meat will be drier.
- When using skewers, thread the meat on them loosely so it browns evenly and the sauce can coat all sides. If using wooden skewers, soak them in cold water for one hour before using to prevent charring.
- Place delicate foods such as fish on heavy-duty aluminum foil placed directly on the grill.
- Use heavy-duty aluminum foil to cover vegetables, sandwiches or bread on your grill. Wrap foil tightly to hold in juices and make food moist and tender, or leave foil loosely wrapped or open at the top for a smoked flavor.
- The best utensils for your modular grill are the same **long-handled utensils with wooden handles** that you use with your outdoor barbeque grill.
- **Always use tongs to turn the food** — a fork will pierce the food, causing loss of juices and increasing the chance of flame-ups.
- Using a marinade before cooking or a sauce during or after cooking will give added flavor and variety to your meals.
- Tomato-based or sweet sauces burn after 15 minutes of cooking, so use them for basting at the end of the cooking time. When basting be careful not to use too much. Excess sauce only drips off making clean up harder. Sugar-based sauces are especially hard to clean.
- To make clean-up easier you may line the reflector plates with aluminum foil. Be sure to cut the foil to match all openings in the reflector plate.
- **Never salt foods on the grill** while cooking as this will make them less juicy. Salt food on a plate after cooking is finished.
- When checking meat doneness, cut a small slit near the bone or center of the meat. If the meat is: red it is rare, pink it is medium or brown it is well done.

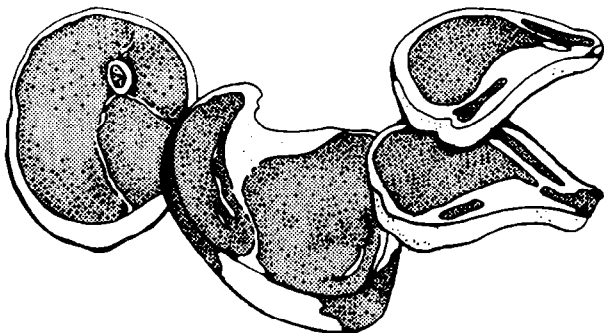

REMOVING THE GRILL MODULE

Be sure the controls are OFF and the unit is cool.

To remove the grill element:

1. Grasp the element with both hands on either side of the plug.
2. Raise the opposite side of the element just enough to clear the well, then pull away from the receptacle. **The element will not sit level when replaced if it is forced too far upward when removed.**

CLEANING THE GRILL MODULE

Clean the grill module after every use. Do not put the element into water. It cleans itself when heated during normal use. To remove any charred soil, clean with a dry, stiff brush when the element is cool. **Never use steel wool or metal scouring pads because they may damage the outer casing of the element.**

Wash the non-stick grill grids at the sink in soap and water. Use a non-metal scouring pad if necessary. **Do not use abrasive cleaning products.**

From time to time, you should recondition the grids with cooking oil as explained on page 13.

Wash chrome plated reflector plates at the sink in soap and water, or put in the dishwasher. Soak stubborn stains then rub gently with a scouring pad.

Do not put the reflector plates or grill grids in the oven during a self-clean cycle. Doing so will cause discoloration and damage the finish.

Wipe out the porcelain well with a damp, soapy cloth and dry. **Check the grease jars and empty or replace them as needed.**

MODULE COVER

The module cover is an optional accessory with several very handy uses. You can:

- protect one side of the cooktop from spatters while cooking on the other side
- use it as a dust cover or to hide a soiled module from view until you have time to clean
- turn the cover over and use it as a tray

Do not place the cover on a hot module or leave it over a grill while preheating. To clean the module cover, wash it at the sink with soap and water and dry. For stubborn soil, just let it soak 5 or 10 minutes or use a nylon brush or pad. **Do not use a metal scouring pad or other abrasives. Do not put the cover in your dishwasher — the wooden handles may be damaged.**

GRILLING CHART

Grill times are for food at refrigerator temperature. If the grill has just been used and is still warm, decrease cooking time 2 or 3 minutes.

Season grill grates. Preheat grill on Hi, 5 to 10 minutes.			
Food	Setting	Cooking Time	Comments
Hamburgers (1/2" – 5/8")	6-7	Rare 8 to 10 min. Med. 10 to 14 min. Well 14 to 20 min.	Turn after half the time.
Steak (1/2" – 3/4")	Hi	Rare 7 to 9 min. Med. 9 to 13 min. Well 13 to 19 min.	Turn after half the time.
Steak (1" – 1-1/2")	Hi	Rare 16 to 20 min. Med. 20 to 24 min. Well 24 to 30 min.	Turn after half the time.
Chicken Pieces: Bone-In Boneless Breasts	6-7 6-7	65 to 75 min. 35 to 45 min.	Turn occasionally. Turn occasionally. Brush with glaze last 15 minutes.
Hot Dogs – small	Hi	4 to 6 min.	Turn frequently.
Lamb Chops	6-7	25 to 35 min.	Turn occasionally.
Pork Chops (1/2") (1")	6-7 6-7	18 to 22 min. 35 to 45 min.	Turn occasionally. Turn occasionally.
Ham Slice (1") – precooked	6-7	15 to 20 min.	Turn once.
Salmon Steak (1")	6-7	20 to 25 min.	Brush with butter. Turn after half the time.
Loaf Garlic Bread	5-6	15 to 20 min.	Wrap in heavy duty aluminum foil. Turn once.
Foil Wrapped Vegetables	6-7	15 to 30 min.	Wash vegetables well, but do not dry. Wrap tightly in heavy duty foil. Turn occasionally.

Corn on the Cob

6 unhusked ears of corn

1. Pull back husk halfway down ear and remove silk.
2. Pull husk back up and tie shut at center with thin wire or heavy cord.
3. Soak ears in water for at least 30 minutes. Drain well.
4. Place corn on grill. Cover with aluminum foil. Grill at Hi for 20 to 30 minutes or until tender. Turn frequently, 1/4 turn at a time.
5. Cut wire or cord, remove husks, season and eat.

NOTE: The ears of corn can be wrapped individually with heavy duty aluminum foil and sealed. They will take 30 to 40 minutes to cook.

Zucchini – Tomato Casserole

2 medium-size zucchini cut into 1/2" slices
2 medium tomatoes, cut into thin slices
1 small onion, thinly sliced
1/2 teaspoon oregano leaves
Salt
Pepper
Salad oil

1. On heavy duty aluminum foil place a layer of zucchini then tomatoes then onion.
2. Sprinkle with oregano, and salt and pepper to taste. Pour a few drops of oil over each zucchini stack.
3. Seal tightly and place on grill. Cook at 6-7 for 15 to 20 minutes or until vegetables are tender. Turn packet over a couple times.

Crunchy Olive Appetizer

- 12 slices of bacon, halved
- 24 large green olives, pitted

1. Precook the bacon until almost done but not crisp.
2. Wrap each olive with a piece of bacon. Hold the bacon in place with a toothpick. (Soak the toothpicks in water so they don't burn on the grill).
3. Preheat grill at Hi.
4. Add olives and cook at Hi for about 5 minutes or until the bacon is crisp, turning as needed.

Makes 24 appetizers

Mushroom Burgers

- 1 lb. ground beef
- 1/8 teaspoon pepper
- 8 large fresh mushrooms, coarsely chopped
- 1 tablespoon finely chopped onion

1. Lightly mix all ingredients and shape into 4 patties, 1/2" to 5/8" thick.
2. Preheat grill at Hi.
3. Cook at 6-7, for 4 to 6 minutes per side for medium rare.

Makes 4 burgers.

Crabmeat Stuffed Chicken

- 1 can (7 oz.) crabmeat, drained and flaked
- 1 egg, slightly beaten
- 2 teaspoons lemon juice
- Salt
- 2 whole chicken breasts, boned and split
- 1/4 cup butter or margarine, melted
- 3 tablespoons soy sauce
- 6 tablespoons Parmesan cheese
- 1/4 teaspoon Worcestershire sauce

1. Combine crabmeat, egg, and lemon juice.
2. Lift chicken skin from flesh, being careful to leave it attached to the longest edge. Salt lightly.
3. Place one fourth of the crabmeat mixture under the skin of each chicken piece. Secure with toothpicks which have been soaked in water.
4. Preheat grill at Hi.
5. Lightly grease grill grids.
6. Combine butter, soy sauce, cheese, and Worcestershire sauce. Baste both sides of chicken with soy mixture.
7. Place chicken on grill skin side up.
8. Cook at 6-7 about 40 minutes turning and basting occasionally.

Makes 4 servings

Hawaiian Kebobs

- 2 lbs. ready-to-eat boneless ham
- 1 cup currant jelly
- 1/2 cup honey
- 2 tablespoons orange juice
- 1 teaspoon cinnamon
- Pineapple chunks
- Spiced apples
- Bananas, sliced 1 inch thick

1. Cut ham into 1 inch cubes.
2. Mix together jelly, honey and orange juice. Heat until jelly melts.
3. Alternately place ham cubes, pineapple chunks, apples and banana slices on skewers. Brush with cooled sauce.
4. Preheat grill at Hi.
5. Cook kebobs at Hi for 6 to 8 minutes or until heated through. Turn and brush kebobs with sauce occasionally.

Makes 6 to 8 servings

Herb Rye Loaf

- 1/2 cup butter or margarine
- 3 tablespoons minced parsley
- 1 clove garlic, minced
- 1/2 teaspoon salt
- 1/4 teaspoon dry mustard
- 1/4 teaspoon pepper
- 1/4 teaspoon rosemary
- 1/4 teaspoon sage
- 1/4 teaspoon tarragon
- 1/4 teaspoon thyme
- 1/4 loaf dark rye bread

1. Cream butter, add remaining ingredients except bread and mix well.
2. Spread mixture generously on every other slice of bread. This lets you choose bread slices in pairs for sandwiches.
3. Reassemble loaf and wrap in heavy duty foil.
4. Cook at 6 for 20 minutes turning occasionally.

Apricot Pork Chops with Apple Rings

- 4 pork chops, cut 1" thick
- 2 large apples, unpeeled and cut horizontally into 1" thick slices
- Apricot Baste (see page 11)

1. Trim fat from pork chops and slash remaining fat to prevent curling.
2. Preheat grill at Hi.
3. Lightly grease grill grids.
4. Cook chops and apple rings at 6-7 for 35 to 40 minutes turning frequently and basting with Apricot Baste.
5. Serve with heated Apricot Baste

INSERTING THE GRIDDLE MODULE

To insert the griddle:

1. Be sure the controls are **OFF**.
2. Insert the reflector plates and the element from the grill module in the manner described in steps 2 and 3 on page 13.
3. Place the griddle into the opening in the cooktop **with the two drain holes toward the front of the cooktop** (nearest the controls). See illustration.

Note: When properly placed the griddle sits slightly above the cooktop. This, and the open spaces on the sides and rear of the griddle, prevent excessive temperatures.

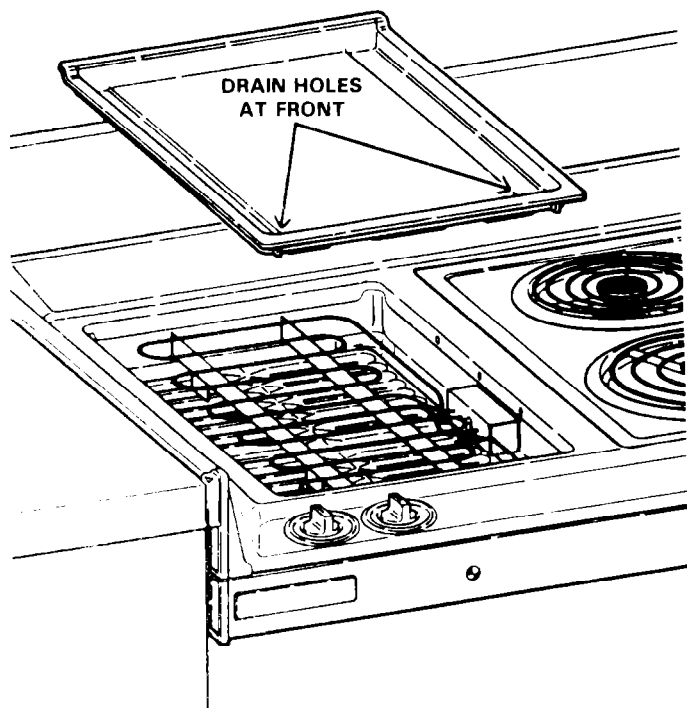

USING THE GRIDDLE

The non-stick griddle must be preconditioned before using it for the first time. To precondition, first wash the griddle in soap and water and dry. Then use a paper towel to apply a small amount of cooking oil to the griddle. Remove excess oil with a clean paper towel.

To preserve the finish, use only Teflon® coated, nylon or wooden spatulas and spoons. **Never use the griddle surface as a cutting board.**

NOTE: Over a period of time, minor scratches and some discoloration may appear in the non-stick coating. This will not affect the cooking performance or the non-stick finish.

Preheat the griddle as recommended in the griddle chart on page 18. After preheating for the recommended time apply a small amount of oil or butter. **Do not overheat the griddle. Leaving the griddle at HI for more than 10 minutes without food can damage the non-stick coating. When griddling a LO blower setting is recommended.**

Remember, because the heating element under the griddle is divided, you can vary the temperature on the front and rear sections. Always turn on both sections of the heating element under the griddle. Heating only part of the griddle may warp it and will result in non-uniform cooking.

REMOVING THE GRIDDLE MODULE

Be sure the controls are OFF and the unit is cool.

To remove the griddle:

1. First, lift the back edge of the griddle a bit to let any excess fat or oil drain, then remove the griddle.
2. Remove the element as described on page 14.

CLEANING THE GRIDDLE

After cooking a greasy food, wipe the non-stick griddle while it is still warm with a dry paper towel. Be careful not to burn your fingers. When cool, wash the griddle at the sink in soap and water. Use a non-metal scouring pad if necessary. **Do not use abrasive cleaning products. Do not wash in the dishwasher.**

From time to time, recondition the griddle with cooking oil as described in 'Using the Griddle' on this page.

It is a good idea to store the griddle on one edge. If you lay it flat, pans or other utensils may be put on top and scratch the non-stick coating.

Follow the cleaning instructions on page 14 for the reflector plates and porcelain well. **Check the grease jar and empty or replace it as needed.**



GRIDDLE CHART

Griddle times are for food at refrigerator temperature. If the griddle has just been used and is still warm, decrease cooking time 2 or 3 minutes.

Season griddle. Preheat for meats at Hi and other foods at cook setting.				
Food	Preheat Time	Cook Setting	Cooking Time	
			1st Side	2nd Side
Bacon	None	4-5	7 to 8 min.	2 min.
Buns	5 min.	4-5	2 to 3 min.	
Eggs, Fried	5 min.	3	2 to 3 min.	1 to 2 min.
Eggs, Scrambled	5 min.	5	3 to 4 min. (total)	
Fish Sticks	5 min.	3-4	4 to 5 min.	3 to 4 min.
French Toast	10 min.	4-5	2 to 3 min.	1 to 2 min.
Ham Slice	5 min.	4-5	5 to 6 min.	4 to 5 min.
Hamburgers	5 min.	3-4	5 to 6 min.	3 to 4 min.
Hot Dogs	5 min.	4-5	turn to brown	
Pancakes	10 min.	4-5	1 to 2 min.	1 to 2 min.
Sandwiches	5 min.	4-5	2 to 3 min.	1 to 2 min.

Reuben Sandwiches

- 8 slices rye bread
- Butter or margarine
- 1/3 cup Thousand Island Dressing
- 4 slices of Swiss cheese
- 8 thin slices cooked corned beef
- 1 can (14 oz.) sauerkraut, rinsed and drained

1. Preheat griddle at 5 for 5 minutes.
2. Butter both sides of bread.
3. Cook bread at 5 for about 3 minutes or until browned.
4. Turn over 4 slices of bread. Spread with 1 tablespoon of dressing. Top with cheese, 2 slices corned beef and sauerkraut.
5. Spread toasted side of the remaining slices of bread with dressing. Place dressing side down on sauerkraut.
6. Cook each side of sandwich at 7 for 1 to 2 minutes or until golden brown and cheese is melted.

Makes 4 sandwiches.

Zucchini Rounds

- 2 cups grated zucchini
- Salt
- 1/3 cup biscuit mix
- 1/4 cup grated Parmesan cheese
- 1/2 small onion grated
- 1 egg
- Pepper

1. Sprinkle salt over zucchini. Set aside a few minutes, then squeeze out excess moisture.
2. Add remaining ingredients and mix.
3. Preheat griddle at 4-1/2 for 10 minutes.
4. Brush griddle lightly with oil.
5. Spread about 2 tablespoons of batter to about a 3" diameter round.
6. Cook at 4-1/2 about 3 minutes on each side, or until golden brown.
7. Serve topped with butter and/or sour cream.

Makes 8 pancakes.

Cheesy Scramble

- 6 eggs, slightly beaten
- 2 tablespoons cream
- 1 pkg. (3 oz.) chive cream cheese
- 1/2 teaspoon seasoned salt
- 1 tablespoon butter or margarine

1. Combine eggs, cream and salt; beat slightly. Add chive cream cheese broken in small pieces.
2. Preheat griddle at 5 for 5 minutes.
3. Melt butter on griddle. Add egg mixture and stir gently until set, about 3 to 4 minutes.

Makes 3 to 4 servings.

Biscuits

- 1-1/8 cups biscuit mix
- 1/3 cup milk
- 1 tablespoon oil

1. Mix together biscuit mix & milk until a soft dough forms, then beat vigorously for 30 seconds.
2. Turn dough onto cloth well dusted with biscuit mix. Knead 10 times. Roll 1/4" thick. Cut with 2 inch cutter.
3. Preheat griddle at Hi for 5 minutes.
4. Turn down to 6 and spread one tablespoon oil on griddle.
5. Cook biscuits 3 to 4 minutes per side or until browned.

Makes 12 biscuits

Herb Meatballs

- 1 lb. lean ground beef
- 1/2 cup dry bread crumbs
- 1 pkg. (0.9 oz.) Vintage Classic Herb Salad Dressing Mix
- 1/3 cup milk
- 1 egg, well beaten
- 1 teaspoon sugar
- 1/8 teaspoon garlic salt
- 1/8 teaspoon pepper
- 1 tablespoon oil

1. Mix all ingredients except oil.
2. Shape into one-inch balls.
3. Preheat griddle at Hi for 5 minutes.
4. Grease griddle with oil.
5. Cook meatballs at 5, turning frequently until done, about 10 minutes.
6. Stick with toothpicks and serve.

Makes about 35 meatballs.

Hash Browns

- 4 medium potatoes, cooked and shredded
- 1/4 cup finely chopped onion
- 1 tablespoon dried parsley (Optional)
- 3/4 teaspoon salt
- 1/4 teaspoon pepper
- 2 tablespoons bacon drippings (or other fat)

1. Mix together potatoes, onion, parsley, salt and pepper.
2. Preheat griddle at 5 for 5 minutes.
3. Melt bacon drippings on griddle.
4. Place potato mixture on griddle and pack together. Spread potatoes so they are 1/4" — 1/2" thick.
5. Cook potatoes 8 to 10 minutes or until browned. Divide into 4 pieces and turn over. Continue cooking another 2 to 4 minutes or until brown and crusty.

Breaded Vegetables

- Zucchini and other summer squash
- Large mushrooms
- Green tomatoes
- 3 eggs
- 1/3 cup melted butter or margarine
- 1 tablespoon milk
- 1-1/2 cups cracker crumbs or dry bread crumbs
- 1 teaspoon salt
- 1/4 teaspoon pepper
- Butter or margarine

1. Cut 1 to 1-1/2 lbs. vegetables into 1/4 inch thick pieces.
2. Mix together eggs, 1/3 cup margarine and milk.
3. Combine cracker crumbs, salt and pepper.
4. Dip vegetables into egg mixture then cracker crumbs. Repeat for a double coating. Let stand 20 minutes.
5. Preheat griddle at Hi for 5 minutes.
6. Turn down to 5.
7. Spread griddle with butter then add coated vegetables.
8. Cook 5 to 6 minutes on each side or until browned.

Toasted Croutons

- 1 quart of 1/2 inch bread cubes
- 4 tablespoons butter or margarine
- 1/2 teaspoon of one of the following — seasoned salt, garlic salt or dill weed

1. Melt butter and add seasonings.
2. Preheat griddle at Hi for 5 minutes.
3. Turn down to 5.
4. Spread half of butter mixture on griddle then add bread cubes.
5. Cook 3 to 5 minutes or until golden brown, turning as needed. Halfway through pour the remaining butter over the bread cubes.

ASSEMBLING THE ROTISS/KEBAB MODULE

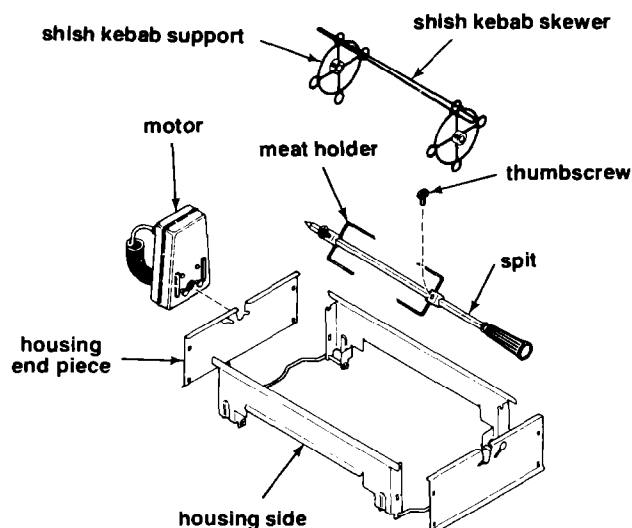

Before assembling your rotisserie module, place the reflector plates and the grill element in the open cooktop well, as explained on page 13.

The two metal pieces connected by the two thick wires are the sides of the rotisserie housing. Lay this piece down flat so that the angled flanges which hold the wires are pointing up.

Have ready the two shorter housing end pieces which will complete the housing.

1. Raise one side of the housing into a vertical position.
2. Hook two of the tabs on an end piece into the corresponding slots in the angled flanges of the housing side.
3. Raise the other housing side and connect it in the same manner.
4. Attach the second end piece by hooking its four tabs into the slots at the opposite end of the housing. The end pieces should be on the outside.
5. The notched circles in the endpiece support the rotisserie motor. The V-shaped notch holds the handle-end of the spit. Grasping the housing on the sides position it over the cooktop well so that the corners of the housing rest on the rim of the well. The motor end should point toward the back. The motor has two small, round studs on one side. Insert these studs into the round openings in the end of the housing and rotate them into the notches. Make sure that the motor cord stays clear of hot elements.
6. Tightly screw the black handle to the threaded end of the spit.

USING THE ROTISSERIE

Cuts of meat to be rotissed should be symmetrical and evenly shaped. They can weigh up to 5½ pounds and can have a diameter of up to 7 inches. Large cuts of boneless meat will need to be tightly tied at 2-inch intervals with strong cord.

Whole poultry will need to be trussed. First, tie legs to each other at the tips, and using same string, secure legs to body. Tightly tie wings to body. Then firmly tie entire bird at intervals making sure that no parts are loose. Delicate poultry parts, such as wing tips, may be shielded with a small piece of aluminum foil.

Insert the spit into the meat so that the meat will be centered and well-balanced. Fasten securely to spit with the meat holders. Leave a few inches empty at each end of the spit.

Insert the tip of the spit into the opening in the motor. Rest the other end of the spit on the opposite side of the housing so that the groove before the handle lays in the V-shaped notch.

Plug the motor into a standard household outlet.

Use your venting system to minimize smoke and odors.

Make sure that as the food turns on the rotisserie it will clear the grill element by at least 1 inch.

ROTISSING TIPS

It is not necessary to preheat the grill element.

All foods may be rotissed on high.

Use a LO blower setting unless excessive smoking occurs.

Use a marinade before cooking or a sauce during or after cooking to give added flavor to your meats. Tomato-based sauces or sugary sauces will burn after 15-20 minutes of rotissing so use them at the end of the cooking time. A butter sauce can be used from the start.

Use a meat thermometer near the end of rotissing time to determine the doneness of your meat. Turn off the grill element and unplug the rotisserie motor. To determine the temperature of the meat roasts, insert the thermometer so that tip is as close to center of roast as possible without touching the spit or any meat fat. To determine the temperature of poultry, insert the thermometer into the center of the inner thigh muscle, making sure that the tip is not in contact with the bone.

After removing meat from the rotisserie allow it to stand and cool 10-15 minutes. This will make it easier to carve.

Refer to the rotissing chart on page 21 for approximate cooking times.

SHISH KEBABING TIPS

Enjoy cooking and entertaining with your shish kebab attachment by combining your favorite foods to create easy, delicious and colorful appetizer kebabs, main dish kebabs and even dessert kebabs!

Foods that lend themselves well to shish kebabing include 1-1 1/2 inch thick pieces of meat, deboned poultry, firm seafood, and canned, pickled or fresh fruits and vegetables.

When cutting meats, poultry, fruits or vegetables, cut each piece of that particular food uniformly so all pieces will be cooked to the same degree of doneness.

Cut meats and seafood fillets into 1-1 1/2 inch cubes. Cut large pieces of fruit or vegetables into 1-1 1/2 inch chunks or wedges.

Firm vegetables, such as onions, zucchini or potatoes, will need to be parboiled or partially pre-cooked before they are added to a skewer which will contain faster cooking food. Marinate meat poultry and seafood several hours in refrigerator before shish kebabing to give added flavor and juiciness.

Thread larger food ingredients on both prongs. Thread smaller ingredients on only one.

A crowded skewer may not cook all foods completely or evenly. Each ingredient should just barely touch the next.

Cook meat kebabs to the well-done stage by leaving a 1-inch space between the meat cube and the next ingredient. Meat cubes placed closer together will cook to the rare to medium stages.

Baste kebabs with marinade or sauce while cooking to keep them flavorful and moist.

When ready to shish kebab, attach the two round shish kebab supports to the spit. Use the thumb screws from the meat holders to fasten the support rings 2-inches from each end of the spit. Insert the pronged end of the food-loaded skewer into the outside ring of one shish kebab support. Snap the widened-end of top of the corresponding outside ring of the other shish kebab support. Then place the spit and start the motor as explained on page 20.

CLEANING THE ROTISS/KEBAB MODULE

Never put the rotisserie motor into water. To remove any grease that may have splattered on it, just wipe the outside housing with a damp cloth.

All other rotisserie parts may be washed in the dishwasher or at the sink in soap and water. A scouring pad may be used if necessary.

Follow the cleaning instructions on page 13 for the reflector plates and the porcelain well. Check the grease jars and empty or replace as needed.

FOOD (at refrigerator temperature)	COOK TIME	FINAL INTERNAL TEMPERATURE
BEEF ROASTS (3-5 lbs) Recommended cuts: Chuck shoulder pot roast, boneless Eye round roast Rib eye roast Round rump roast, boneless Round tip roast Top round roast	19-23 min./lb. (rare) 24-28 min./lb. (medium) 29-33 min./lb. (well)	140 °F 160 °F 170 °F
PORK ROASTS (3-5 lbs.) Recommended cuts: Shoulder blade (Boston) roast, boneless Pork loin sirloin roast, boneless Fresh ham roast, boneless	27-37 min./lb.	170 °F
HAM (3-5 lbs.) Boneless and fully cooked	14-18 min./lb.	140 °F
VEAL (2-4 lbs.) Recommended cuts: Shoulder roast, boneless Leg sirloin roast, boneless Leg rump roast, boneless	35-45 min./lb.	170 °F
LAMB (3-5 lbs.) Recommended cuts: Shoulder roast, boneless Leg roast, boneless	15-20 min./lb. (rare) 21-27 min./lb. (medium) 28-37 min./lb. (well)	140 °F 160 °F 170 °F
WHOLE CHICKEN (2-3 lbs) Fryer	1 hr. 45 min.	185 °F
TURKEY BREAST (3-5 lbs.) Boneless	36-40 min./lb.	185 °F
CORNISH HENS (1 to 1 1/2 lbs. each) Single hen Up to three Cornish hens may be rotissed at one time. They may be skewered end-to-end or side-to-side. Add thirty minutes cooking time for each additional hen.	1 hr. 10 min.	185 °F

USING THE OVEN

The oven of your new range is entirely controlled by the Electronic Range Control. When the oven is in use the blower of the downdraft venting system will come on automatically to keep internal components cool and to vent oven smoke and odors to the outside. For oven use a LO blower setting is recommended. Follow instructions below.



To Set the Clock:

1. Push CLOCK button.
2. Turn SET knob to current time of day.

To Set the Timer:

1. Push TIMER button.
2. Turn SET knob to desired amount of time (up to 9 hours, 55 minutes).
3. To cancel TIMER, push TIMER button and turn SET knob back to 0:00.
4. When time is up a tone will sound three times.

Note: The timer is a reminder only and will not operate the range.

To Bake:

1. Push BAKE button.
2. Turn SET knob to desired temperature. When a few seconds have passed, after setting the temperature, the display will show the oven temperature as it rises (in 25° steps). Push the BAKE button again to show the temperature you have selected. Do not move the SET knob when the rising temperature is being shown. Doing so will change the selected temperature.
3. When finished baking, push the OVEN OFF button.

To Broil (Top Element Only):

1. Push BROIL button.
2. Turn SET knob to HI or LO Broil (see page 21).
3. When finished broiling, push the OVEN OFF button.

To Use Timed Oven/Delay Start

Program your Electronic Range Control for timed oven operations. Fix your food as you would normally and let the oven do the rest. Follow the step by step instructions below:



Never let food sit for more than 4 hours before cooking starts, when you set your oven for a delay start. Room temperature is ideal for the growth of harmful bacteria. Be sure the oven light is off because heat from the bulb will speed bacteria growth.

To Start Now and Stop Later:

1. Push COOK TIME button.
2. Set length of baking time with SET knob.
3. Push BAKE button.
4. Set desired temperature with SET knob.

To Start Later and Stop Later:

1. Push COOK TIME button.
2. Set length of baking time with SET knob.
3. Push STOP TIME button.
4. Set time of day when baking should be completed.
5. Push BAKE button.
6. Set desired temperature with SET knob.
7. When STOP TIME is reached, 3 beeps will sound. To turn tone off before third beep push OVEN OFF button.

When a timed function has been programmed you can recall what has been entered by pushing the corresponding function button. If, for example, you have programmed in a delayed timed bake operation and currently the time of day is displayed, simply push STOP TIME to find out when the cycle will stop or BAKE TIME for length of baking time entered. The messages at the left-hand side of the display show you which operation is currently being displayed.

The other tones, besides the three beep end of cycle tone, programmed into the Electronic Range Control are:

1. **Attention tone** (quarter second on, one second off): will sound if oven has only been partially programmed, until proper response is given. For example if you have programmed in a bake time but no temperature, you will hear the attention tone until the temperature is entered.
2. **Failure tone** (rapid beep): display will show FO-F5. Cancel tone by pushing OVEN OFF button. Try programming the operation again. If you still get a failure message, call for service. If you are unable to cancel tone with the OVEN OFF button, unplug the range or disconnect circuit breaker.

OVEN LIGHT

There are two rocker switches on the front of the range. The one on the left is a three-position switch. Push the top portion of the switch to turn the oven light on. Pushing the bottom portion of this switch turns on the blower. The middle setting of the switch is the OFF position for the oven light and the blower. Remember that the blower will come on automatically when the oven or rear cooktop controls are being used, even if the switch is in the OFF position.

PREHEATING

Preheating lets the oven heat evenly throughout before the food is put in the oven. Allow 10 minutes at temperatures less than 350°F and 15 minutes at 350°F or more.

USING FOIL

For Baking

To catch spillovers, cut a piece of foil slightly larger than the pan and turn up the edges. Use two oven racks and put the foil on the lower oven rack below the pan. Do not use aluminum foil directly under a pan on the same oven rack. The foil will reflect heat away from the pan.



Do not cover the oven bottom or an entire oven rack with foil. The foil can block normal heat flow, cause cooking failures, and damage the oven interior.

For Roasting

For slow browning, place a foil "tent" loosely over the meat. This is especially good on a large turkey. The "tent" lets oven heat circulate under the foil. Sealing the foil will tend to steam the meat.

To reduce spattering, lightly crush foil and put it in the bottom of the pan under the food.

For Broiling



Do not cover the entire broiler grid with foil. Poor drainage of hot fat may cause a broiler fire. If a fire starts, close the oven door and push the OVEN OFF button. If fire continues, throw baking soda on the fire. Do not put water or flour on the fire. Flour may be explosive.

If you feel you must use foil, cut slots in the foil to match all openings in the broiler grid. Fat can then drip away from the meat and be cooled in the pan.

BROILING TIPS

- Your oven door should be open to the broil stop position while broiling (see page 28). If the door is closed, the food will roast and not broil.
- Use only the broiler pan and grid furnished with your range for broiling. They are designed for proper drainage of fat and liquids and help prevent spatter, smoke or fire.
- Do not preheat when broiling. For even broiling on both sides, start the food on a cold pan. Allow slightly more than half the cooking time for the first side then turn the food using tongs. If you pierce the meat with a fork, the juices will escape.
- When broiling frozen meat, use one rack position lower than recommended and up to 1½ times the suggested broiling time.

- Trim the outer layer of fat from steaks and chops. Slit the fatty edges to keep the meat from curling.
- Always put the food being broiled the proper distance from the broiler (see chart below). Food placed too close to the broiler may spatter, smoke or catch fire.
- For maximum juiciness, salt the first side just before turning the meat. Salt the second side just before serving.
- Brush chicken and fish with butter several times as they broil. When broiling fish, grease the grid to prevent sticking.
- Never leave a soiled broiler pan in the range. Grease in the pan may smoke or ignite the next time the oven is used. See page 25 for tips on cleaning the broiler pan and grid.
- Be sure you know the correct procedure for putting out a grease fire. See page 5.

POSITIONING BROILER PAN

After placing food on the broiler pan, put the pan on an oven rack in the proper rack position. The recommended rack position and cooking time can be found in the chart below. Your new range has two Broil temperatures. Use LO Broil for delicate foods such as fish and chicken, melting cheese on openface sandwiches, meringues, etc. Use HI Broil for broiling other meats.

The closer the food is to the broil element, the faster the meat browns on the outside, yet stays red to pink in the center. Moving the meat farther away from the element lets the meat cook to the center while browning outside.

Food	Rack Position 4 = Highest 1 = Lowest	Total Time (Minutes)
Steak - 1" Thick		
	Rare	10-12
	Medium	14-16
	Well Done	20-22
Ground Beef Patties		
	Medium	11-13
	Well Done	13-15
Lamb Chops - 1" Thick	3	16-20
Pork Chops - 1" Thick	3	20-25
Pork Shoulder Steaks	3	15-20
Ham Slice - 1" Thick	3	14-16
Fish (Fillets)	3	10-15
Chicken (Halves)	1	40-60
Frankfurters	3	10-15
Bacon	3	5-7
Open-face Sandwiches	2	6-10

USING A MEAT THERMOMETER

Insert the thermometer into the center of the largest muscle of meat, or in the inner thigh or breast of poultry. For an accurate reading, the tip of the thermometer should not touch bone or gristle or rest in a pocket of fat.

As the meat cooks, the thermometer may slip from its original position. If the reading of the thermometer seems unusually high for the length of time the meat has cooked, check the thermometer and reposition it if necessary.

If you let a roast stand 10 to 20 minutes after you remove it from the oven, it will be easier to carve and the internal temperature will raise as it stands. Remove the roast from the oven when the thermometer reads 5°F to 10°F less than the internal temperature you desire. If you do not plan to let the roast stand, leave the meat in the oven until the full temperature is reached.

RACK AND PAN ARRANGEMENT

Put oven rack(s) in place before turning on the oven. Rack positions are numbered 1 to 4, starting at the bottom with number 1. In general, when using only one rack, position No. 2 should be used. When using two racks, positions No. 2 and 4 work best.

Pans too close to each other, to oven walls or to the oven bottom block the free movement of air. Improper air movement causes uneven browning and cooking.

Normally there should be 1 ½ to 2 inches of air space on all sides of each pan in the oven. See tips below.

When using a large flat pan that covers most of the rack, center on one rack.

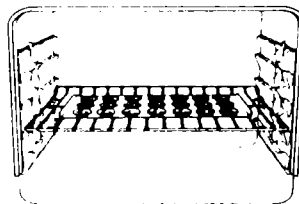

Sheet Cake, Cookies, Biscuits

When baking a sponge or angel food cake, center on one rack in the lowest position.

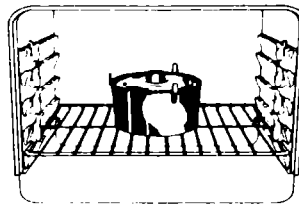

Angel Food or Sponge Cake

The pan or pans using the least amount of rack area should be placed on the lower of the two racks.

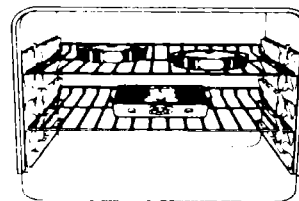

Cake Layers, Pies, Casseroles, 3 Pans

When using two racks and several pans, stagger them so no pan is directly above another.

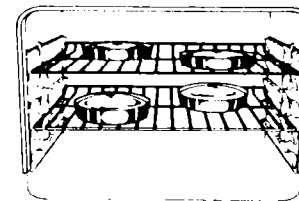

Cake Layers, Pies, 4 Pans (staggered)

CHOOSING OVEN COOKWARE

Aluminum	Absorbs heat faster than glass or steel and conducts heat well. Produces delicate browning, tender crusts, and reduces spattering of roasts. Best for cakes, muffins, quick breads, cookies and roasting.
Ovenproof Glass/Pottery	Because this cookware absorbs heat quickly and holds it well, you should lower your oven temperature 25 °F. Gives food a deep, crusty brown top. Best for casseroles.
Teflon, Dull or Darkened Cookware	Absorbs heat quicker than shiny cookware. Lower your oven temperature 25 °F (except for pastry). Good for pies and other foods baked in pastry shells.

COMMON BAKING PROBLEMS AND CAUSES

CAKE RISES UNEVENLY

- Range or oven rack not level
- Pan warped
- Batter spread unevenly in pan
- Pans too close to oven wall or rack too crowded

CAKE HIGH IN MIDDLE

- Too much flour
- Oven temperature too high

CAKE NOT DONE IN CENTER

- Wrong pan size
- Oven too hot
- Pan not centered in oven

CAKE FALLS

- Too much shortening, liquid or sugar
- Temperature too low
- Pan too small
- Oven door opened too often
- Too much leavening or stale leavening
- Overmixing after adding flour

BOTTOM PIE CRUST SOGGY

- Filling too juicy
- Filling allowed to stand in pie shell before baking
- Used shiny pans
- Temperature too low at start of baking
- Crust and/or filling not allowed to cool before filling crust

BURNING AROUND EDGES OF PIE CRUST

- Oven temperatures too high
- Edges of crust too thin or too high
- Oven too full or pans too close together

COOKIES AND BISCUITS BURN ON BOTTOM

- Oven preheat time too short
- Pan too deep or too large
- Used dark pans
- Used incorrect rack position

FOOD NOT DONE AT END OF COOKING TIME

- Oven temperature set too low
- Oven too crowded
- Oven door opened too often
- Aluminum foil blocking air movement

Outside Finishes:		
Chrome	Wash with soap and water . For heavy soil, cover with a damp cloth and let soak 30 minutes. A chrome cleaner may be used. To remove fingerprints on brushed chrome,	apply a small amount of baby oil or cooking oil with a cloth or paper towel. Rub in the same direction as the brush marks on the chrome.
Glass (oven door)	Wash with a soapy cloth, well wrung out. Remove stubborn soil with a paste of baking soda and water or ammonia and water . Do not use abrasive materials. Before using an all-purpose cleaner, check the label to be sure it is recommended for glass – some will	permanently damage glass. To help prevent a brown residue from forming on the oven window the next time the oven is heated, rinse the inside of the window with vinegar and water , then dry.
Paint (lower panel)	Wash with soap and water then rinse with vinegar and water and dry with a paper towel. Avoid cleaning powders or abrasives	which may scratch the surface.
Vinyl	Wash with soap and water then dry. Do not use abrasive or caustic cleaners.	
Oven Finish:		
Self-Cleaning	See pages for clean cycle information. Use soap, water and a scouring pad for touch up cleaning between self-cleaning cycles. Avoid any contact with the oven door	seal (see below). Never use any oven cleaners. To be sure that all cleaner residue has been removed give a final rinse of vinegar and wash.
Oven Door Seal	Soak soiled area with hydrogen peroxide (see page 26).	
Oven Racks	Remove from oven (see instructions on page 18) and wash at sink with soap, water and a scouring pad.	
Broil Pan and Grid	Do not leave in range to cool. If you clean immediately, the soil will steam loose while you are eating. Remove pan from oven and remove fat and drippings. Sprinkle pan with detergent then cover with a wet cloth or	paper towel and let soak. Later wash in soap and water using a scouring pad as necessary. Both the pan and grid are dishwasher safe.

BEFORE A CLEAN CYCLE

1. Remove the broil pan and grid, oven racks, all utensils and any foil that may be in the oven. If oven racks are left in the range during a clean cycle, they will darken, lose their luster and become hard to slide.
2. Soil on the oven front frame, under the front edge of the cooktop, the door liner outside the door seal and the front edge of the oven cavity (about 1" into the oven) will not be cleaned during a clean cycle (see illustration below). Clean these areas by hand before starting a clean cycle.

Use detergent and hot water with a soap-filled steel wool pad, then rinse well with a vinegar and water mixture. This will help prevent a brown residue from forming when the oven is heated.

3. Wipe up excessive spillovers on the oven bottom. Too much heavy soil may cause smoking during the clean cycle.
4. Clean the door seal by using a clean sponge to soak the soiled area with hydrogen peroxide. Repeated soaking may be needed depending on the amount of soil. Frequent cleaning will help prevent excessive soil build up. Do not rub the door seal excessively. The fiberglass material of the seal has an extremely low resistance to abrasion. Any cotton material especially (including cottonballs), can easily rub a hole into the seal. Do not use any cotton materials to clean the seal. An intact and well fitting oven door seal is essential for energy efficient oven operation and good baking results. If you notice the seal becoming worn, frayed or damaged in any way or if it has become displaced on the door you should replace the seal.

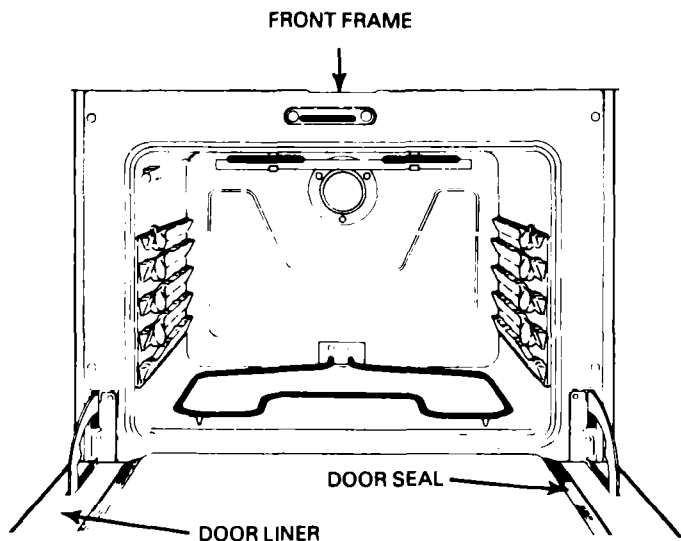

DO NOT use commercial oven cleaners or oven protectors in or near the oven. These products plus the high temperature of the clean cycle may damage the porcelain finish.

DO NOT clean glass ceramic cookware or any other cookware in the oven during a self-clean cycle.

IMPORTANT INFORMATION

All controls must be set correctly for the clean cycle to work properly. To help you understand how the clean cycle works, the stages of the cycle are noted below.

1. The controls are set and the door lock handle moved right into the lock position.
2. The oven begins to heat.
3. For your safety, when the locking temperature is reached the oven door can not be opened. Trying to move the door lock handle during the clean cycle will interrupt the cycle.
4. When the 3½ hour clean cycle is over the oven begins to cool.
5. When the temperature has fallen below locking temperature (about 20-30 minutes after oven goes off at end of clean cycle) the door can be opened.
6. The blower will come on during the clean cycle to discharge cleaning fumes and odors through the outside vent.

After a cleaning cycle, the oven door cannot be unlocked unless:
The temperature has had time to drop to a safe level (20-30 minutes).

TO SET A CLEAN CYCLE

The self-cleaning cycle is preprogrammed for 3½ hours. You can also set the electronic range control for a delayed start of the clean cycle. During the clean cycle a LO blower setting is recommended.



To self-clean:

1. Slide the door lock handle to the right. You may need to press the door slightly to get it to lock properly.
Never try to force the door lock handle. Forcing the handle may damage the door locking mechanism.

2. Push CLEAN button.

You can find out when the clean cycle will be finished by pushing the STOP TIME button.

To use delayed self-clean:

1. Push STOP TIME button.
2. Turn SET knob to time of day when you wish cleaning to be completed (must be more than 3½ hours later than current time of day).
3. Slide the door lock handle to the right. You may need to press the door slightly to get it to lock properly. **Never try to force the door lock handle.** Forcing the handle may damage the door locking mechanism.
4. Push CLEAN button.

TO STOP A CLEAN CYCLE:

1. Press the OVEN/OFF button.
2. Wait until the oven has cooled below locking temperature (20-30 minutes).
3. Slide the door lock handle left to unlock the door. If the door lock handle does not move easily, wait a few more minutes, then try again. You will not be able to unlock the oven unless the oven temperature is below 450 °F. **Never force the door lock handle.**

WHEN A CLEAN CYCLE IS FINISHED.

1. Wait until the oven has cooled below locking temperature (20-30 minutes).
2. Slide the door lock/handle left to unlock the door. If the door lock handle does not move easily, wait a few more minutes, then try again. You will not be able to unlock the oven unless the oven temperature is at a safe level. **Never force the door lock handle.**

AFTER A CLEAN CYCLE

After a clean cycle, you may notice some white ash in the oven. Just wipe it up with a damp cloth.

If white spots remain, remove them with a soap-filled steel wool pad. These deposits are usually a salt residue that can not be removed by the clean cycle.

If the oven is not clean after one clean cycle, the cycle may be repeated.

REMOVABLE OVEN DOOR

To remove:

1. Open the door to the stop position (see illustration).
2. Grasp the door at each side and lift up and off the hinges.

See the cleaning chart on page 25.

NOTE: When the door is removed and hinge arms are at stop position, do not bump or try to move the hinge arms. The hinges could snap back causing an injury to the hands or damage to the porcelain on the front of the range. Cover the hinges with toweling or empty towel rolls while working in the oven area.

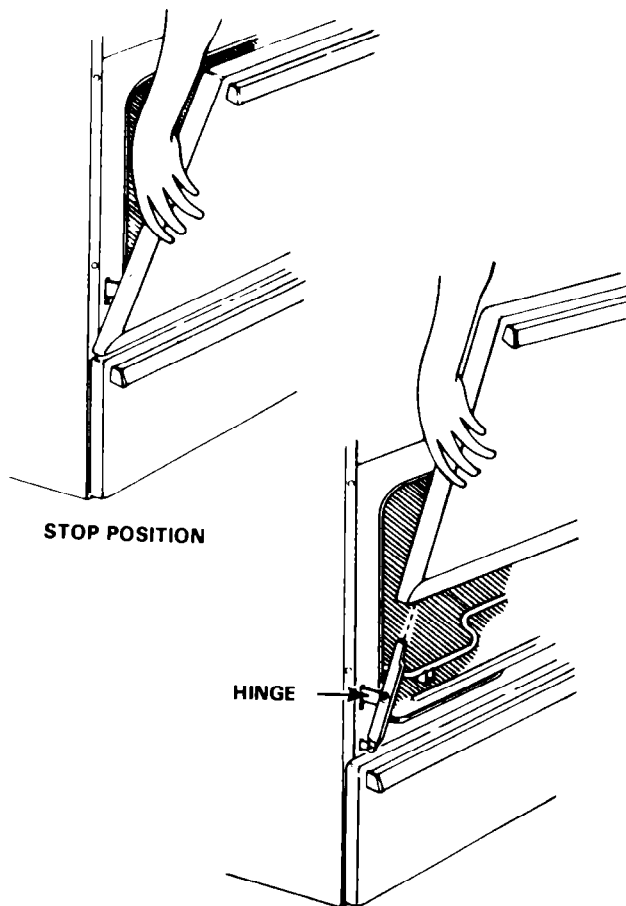

To replace:

1. Hold the door over the hinges with the slots at the bottom edge of the door lined up with the hinges. The hinge arms must still be in the stop position.
2. Slide the door down onto the hinges as far as it will go and close the door.

REMOVABLE OVEN RACKS

Be careful not to scratch the oven finish when installing or removing oven racks.

To install:

1. Set the raised back edge of the rack on a pair of rack guides.
2. Push the rack in until you reach the bump in the rack guide, then lift the front of the rack a bit and push the rack all the way in.

To remove:

1. Pull the oven rack out, then up, in one motion.

See the cleaning chart on page 25.

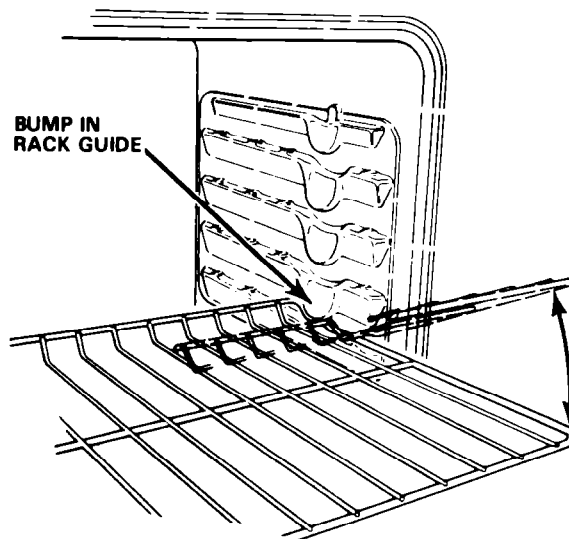

REPLACING THE OVEN LIGHT

Do not touch oven bulb when hot, with wet hands, or wipe oven light area with wet cloth. Unplug or disconnect the electrical supply to range before removing.

Never touch the electrically live metal collar on the bulb when replacing it.

Electrical power *must* be shut off if you have to replace a broken bulb.

1. Remove the three screws and lift off the glass retainer, glass cover and gasket.
2. Replace the bulb with a 40 watt appliance bulb.
3. Replace the gasket, glass cover and glass retainer. Tighten screws securely.

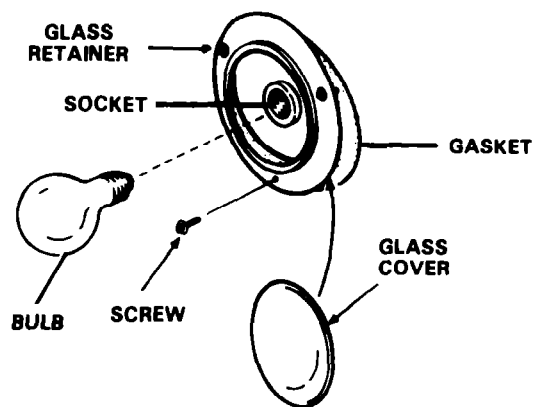

IF YOU HAVE A PROBLEM

COOKTOP KNOBS WILL NOT TURN

- To turn from Off position, push the knob in and then turn.

AN ELEMENT DOES NOT WORK

- Fuse blown or circuit breaker tripped. Power outage — check by trying household lights.
- Check to be sure the individual element and/or module is plugged in firmly. See the following pages:

Open Coil or Solid Element Module — Page 9
Grill/Griddle Element — Page 13

GRILL OR GRIDDLE DOES NOT GET HOT ENOUGH

- The grill/griddle element is not plugged into the well receptacle firmly and is not making complete contact. See pages 13 and 17.
- When griddling use a LO blower setting.

EXCESSIVE SMOKE, OR VENT SYSTEM IS NOT CAPTURING THE SMOKE

- The vent fan is not turned on (when using front controls).
- Too much cross ventilation in the room draws smoke away from the cooktop before the vent system can eliminate it.
- The grill was not cleaned properly the last time it was used and accumulated grease is causing excessive smoke. See page 14 on cleaning the grill module.
- Excessive smoke is being created because excess fat was not trimmed from the meat and is dripping on the grill element. See page 13.
- The grease filter is not clean.

FOOD STICKS TO THE GRILL OR GRIDDLE

- The grill or griddle was not preconditioned before the first use. See page 13 or 17.
- Food is being cooked on too high a heat setting.
- The non-stick coating has been damaged with sharp utensils or the use of abrasive cleaners.
- Leaving the griddle on HI setting for more than 10 minutes without food can damage the non-stick coating and cause sticking.
- The grill grid or griddle was not greased before cooking.

THERE IS GREASE BELOW THE RANGE

- The grease jar is full and has overflowed. You should check the jar each time you use the grill or griddle and empty or replace it often. See page 8.

FOOD GETS BURNED OR TOO WELL DONE ON THE GRILL OR ROTISSERIE

- Excessive fat should be trimmed from the edges of meat. As the food cooks, fat melts and drips on the element causing little bursts of flame. Excessive flame-up causes food to burn or get too well done.
- Salting food while it is cooking draws natural juices out of the food and tends to dry the food.
- Always use tongs to handle or turn food on the grill. Piercing food with a fork causes juices to be lost and dries the food.

COOKING RESULTS ARE NOT WHAT YOU EXPECTED

- See the cooking charts in each section of this manual for general guidelines. Remember, you may need to make cooking time and/or heat setting adjustments for the food you are cooking. Food temperature, thickness and moisture content all affect cooking time and heat settings.

- Are you using a tested recipe from a reliable source? Are you following all the instructions in the recipe, such as pan size, preheating, using all ingredients called for?
- Check to be sure the range and oven rack are level. See your Installation Guide for leveling instructions.
- Oven too crowded, or using wrong rack position. See pages 23, 24 and 25 for tips.
- Using improper cookware. See tips on pages 9, 11 and 12.
- Blower not on LO setting when using the oven.
- May need wall cap restriction. See "Special Installation Instructions" sheet.

SOLID CAST IRON ELEMENTS ARE RUSTING

- Are you using wet pans on the elements? Always be sure pan bottoms are dry before placing them on solid elements.
- When you clean the elements or have a water spill do you remember to turn the elements on a few minutes to dry them completely?
- Did you leave a salt spill on the element? Salt corrodes cast iron.
- Are you using the aluminum element covers that can be bought in many stores to hide electric cooktop elements? These covers hold moisture and condensation and promote rusting.

FOOD COOKS SLOWLY ON THE SOLID ELEMENTS

- The pan bottom is not flat and does not touch the element completely.
- The pan is smaller than the element. This causes the element to start overheating and then automatically reduce the heat.

OVEN LIGHT WILL NOT WORK

- Check to be sure range cord is plugged into outlet completely. Check for a blown fuse or tripped circuit breaker.
- Check for power outage.
- Check for loose or burned out bulb. See page 29 for replacement instructions.

CLOCK/TIMER DOES NOT WORK

- Check to be sure range cord is plugged into outlet completely. Check for a blown fuse or tripped circuit breaker.
- Check for power outage.
- Check step by step operating instructions on page 22.

OVEN/BROILER ELEMENT DOES NOT WORK

- Check to be sure the range cord is plugged into the household outlet completely. Check for blown fuse or tripped circuit breaker.
- Check for power outage.
- Are Timed Oven controls set properly? See pages 22 and 27 for step by step instructions.

BROILING PROBLEMS

- Broil cycle not set correctly. See page 22.
- Using wrong rack position. See chart on page 23.
- Aluminum foil not used properly and grease can not drain correctly. See page 23.

OVEN/BROILER SMOKING

- Broiler pan full of grease left in range from the last time you broiled food. Dirty broiler pan must not be left in the range or smoking and a broiler fire can result the next time the oven is used.
- Aluminum foil not used properly and grease can not drain correctly. See page 23.

OVEN WILL NOT SELF-CLEAN

- Set cleaning time was not long enough. A heavily soiled oven requires 3½ hours.
- Oven controls not set properly. Review step by step instructions on page 27.
- Heavy spillovers were not wiped up before starting clean cycle. See page 26.
- Oven was too dirty and should be cleaned more often.
- May need wall cap restriction. See "Special Installation Instructions" sheet.
- Oven door lock handle was moved during the cycle this will interrupt the cycle. To start again follow instructions on page 25.

OVEN DOOR WILL NOT UNLOCK AFTER SELF-CLEANING CYCLE

- The oven has not cooled to the unlocking temperature. The door can not be unlocked until the temperature drops to a safe level.

MODULES AND ACCESSORIES

Complete use and care instructions for each module and accessory are included in this manual. To purchase additional modules or accessories, contact your authorized Roper dealer. Stock numbers are listed below.

Open Coil Element Module

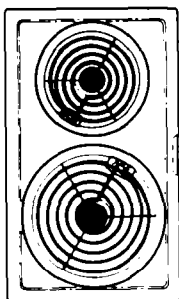

This module has one 6" and one 8" open coil element. The elements and reflector bowls are removable for cleaning.

Stock Number
2A20C-Chrome
2A2LC-Almond

Solid Element Module

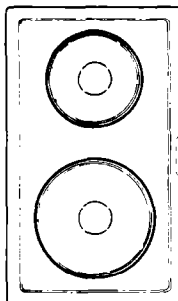

This module has one 6" and one 8" solid element. The elements are made of cast iron and are sealed to the cooktop. Each element has a built-in protector that keeps it from getting too hot.

Stock Number
2A30C-Chrome
2A3LC-Almond

Grill Module

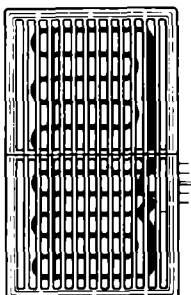

With this module you can char-broil meat indoors all year long. Fat drains away and collects in a jar below the cooktop. The element is divided so the front and back sections can be controlled separately.

Stock Number
2A15G

Griddle

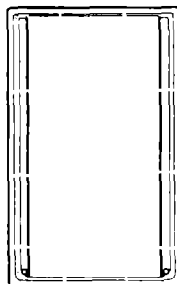

The griddle sets directly over the grill element. It has two drain holes so fat and meat drippings can drain into a jar below the cooktop. The front and back of the griddle are controlled separately.

Stock Number
2A50G

Cover

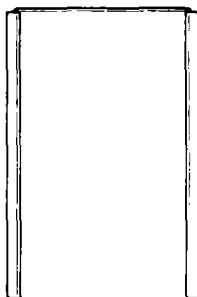

The cover fits over any module. It is textured steel with hardwood handles along each side. It can be used as a dust cover or to hide a soiled module. If turned over, it can be used as a tray.

Stock Number
2A60C

Rotiss/Kebab Module

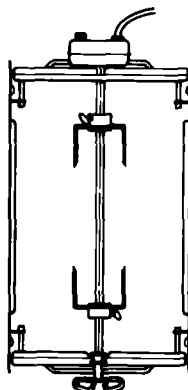

The Rotiss/Kebab module includes a chrome finished motor, stainless steel housing and all skewers and brackets needed for roasts and shish kebabs. The motor turns the food over the grill element and plugs into a standard household outlet. The housing is easily disassembled for storage.

Stock Number
2A70ROE

LIMITED WARRANTY

Roper Corporation warrants to the original consumer Purchaser that this product is free from defects in materials and workmanship. Any parts which we find to be defective will be repaired or replaced at our option, including labor to repair or replace such parts, without charge to the original purchaser. This warranty is subject to the following limitations.

- (1) Repair or replace during the first thirty (30) days from date of purchase any finishes (porcelain, enamel or other) and glass parts which we find to be defective.
- (2) Repair or replace during the first (1st) year from date of purchase any other part except for the finish, which we find to be defective.
- (3) Repair or replace during the first five (5) years from date of purchase any magnetron (on those units so equipped) which we find to be defective. Service on any magnetron under this warranty is limited to the first (1st) year from date of purchase.
- (4) Replacement parts furnished under the terms of this warranty are warranted only for the unexpired portion of the original warranty period and transportation charges relative to obtaining parts involved is the responsibility of the original consumer Purchaser.
- (5) This warranty applies only to products properly installed, adjusted and operated in accordance with instructions found in the product literature. This warranty does not apply to any product which has been subjected to alteration, misuse, abuse, improper installation or delivery damage. Nor does it apply to costs for any service requested for demonstration or to confirm proper operation of the appliance.
- (6) Purchaser must make any claim under this warranty through the dealer, builder or utility from whom this product was purchased and any warranty work must be performed by an authorized Roper Dealer or Service Agency.

If you have any questions concerning this warranty, contact:

**National Service Manager — Roper Sales Corp
P.O. Drawer R — LaFayette, Georgia 30728 USA**

giving the model number, serial number and date of purchase of your product and the name and address of the authorized Roper Dealer from whom it was purchased.

Under no circumstances shall we be liable under this warranty for any loss or for any incidental or consequential damages and all **IMPLIED WARRANTIES ARE LIMITED TO THE SAME TIME PERIODS STATED HEREIN FOR EXPRESS WARRANTIES**. Some Provinces do not allow the exclusion or limitation of consequential damages or limitations of how long an implied warranty may last, so the above limitations or exclusions may not apply to you. This warranty gives you specific legal rights, and you may have other rights which vary from Province to Province.

THIS IS A LIMITED WARRANTY WITHIN THE MEANING OF THAT TERM AS DEFINED IN THE MAGNUSON-MOSS ACT OF 1975.

ROPER SALES CORP.
DIVISION OF ROPER CORPORATION
KANKAKEE, IL 60901

4347928