

NOTE :

CIRCUIT SHOWN WITH ALL CONTROLS SET TO "OFF".
OVEN DOOR CLOSED AND UNLOCKED.

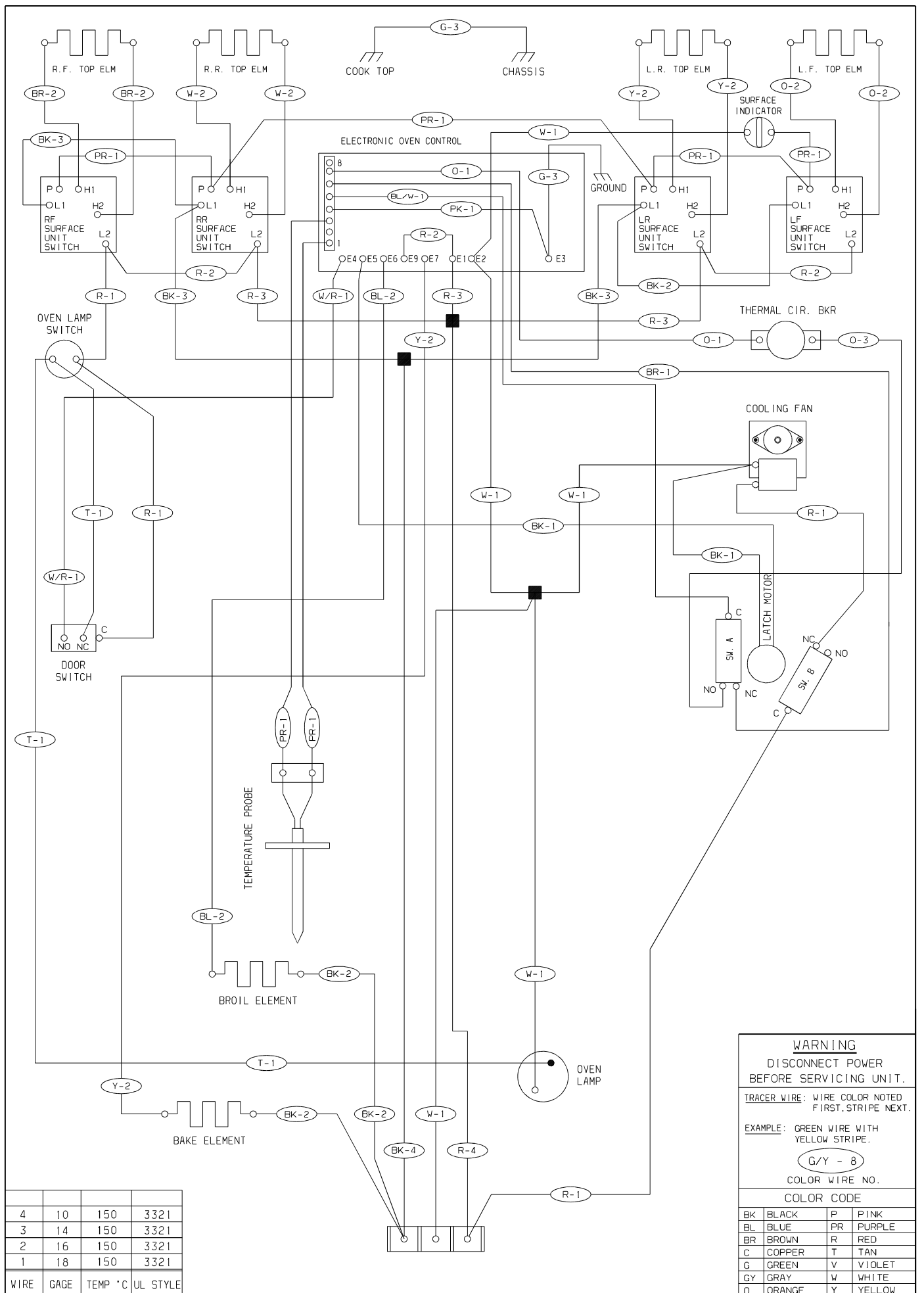

| WIRE | GAGE | TEMP °C | UL STYLE |
|------|------|---------|----------|
| 4 | 10 | 150 | 3321 |
| 3 | 14 | 150 | 3321 |
| 2 | 16 | 150 | 3321 |
| 1 | 18 | 150 | 3321 |

WARNING
DISCONNECT POWER BEFORE SERVICING UNIT.

TRACER WIRE: WIRE COLOR NOTED FIRST, STRIPE NEXT.

EXAMPLE: GREEN WIRE WITH YELLOW STRIPE.

(G/Y - 8)

COLOR WIRE NO.

COLOR CODE

| | | | |
|----|--------|----|--------|
| BK | BLACK | P | PINK |
| BL | BLUE | PR | PURPLE |
| BR | BROWN | R | RED |
| C | COPPER | T | TAN |
| G | GREEN | V | VIOLET |
| GY | GRAY | W | WHITE |
| O | ORANGE | Y | YELLOW |