

PRODUCT MODEL NUMBERS

MGD6300T MGD6400T

Gas supply: Dryer is equipped for use with Natural gas. Dryer can be converted to L.P. gas. 1/2" IPS pipe is recommended. When acceptable to the gas supplier and local codes, 3/8" approved aluminum or copper tubing may be used for lengths under 20 ft. (6.1 m). For lengths over 20 ft. (6.1 m), larger pipe should be used. Pipe-joint compounds resistant to the action of L.P. gas must be used. An individual manual shutoff valve must be installed within 6 ft. (1.8 m) of the dryer in accordance with the National Fuel Gas Code, ANSI Z223.1.

Electrical: A 120 volt, 60 Hz, AC only, electrical supply is required on a separate 15 or 20 amp circuit, fused on both sides of the line. A time delay fuse or circuit breaker and a separate circuit serving only this dryer are recommended.

Exhaust venting: Exhaust your dryer to the outside. 4" (10.2 cm) diameter vent is required. Heavy metal exhaust vent and clamps must be used. Do Not use plastic or metal foil vent. Exhaust hood must be at least 12" (30.5 cm) from the ground or any object that may be in the path of the exhaust.

OVERALL DIMENSIONS

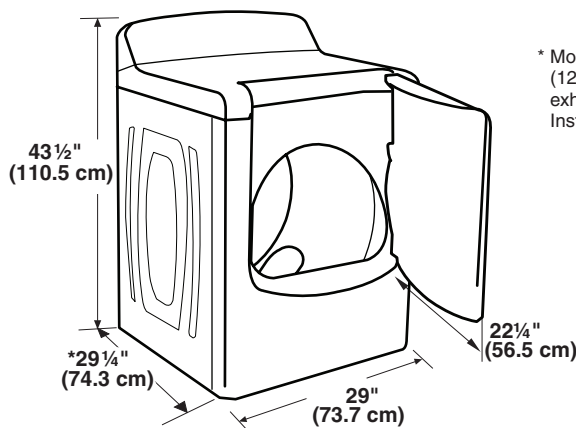

* Most installations require a minimum 5" (12.7 cm) clearance behind the dryer for the exhaust vent with elbow. See Installation Instructions, "Venting Requirements."

RECESSED AREA AND CLOSET INSTALLATION

For closet installation, with a door, the minimum ventilation openings in the top and bottom of the door are required. Louvered doors with equivalent air ventilation openings in the top and bottom are acceptable.

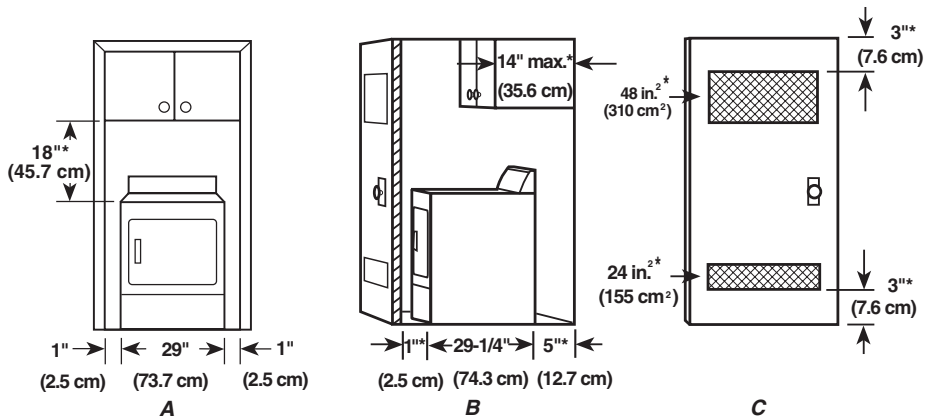

A. Recessed area
B. Side view - closet or confined area
C. Closet door with vents

EXHAUST VENTING

Number of 90° turns or elbows	Type of vent	Box or Louvered hoods	Angled hoods
0	Rigid metal Flexible metal	64 ft (20 m) 36 ft (11 m)	58 ft (17.7 m) 28 ft (8.5 m)
1	Rigid metal Flexible metal	54 ft (16.5 m) 31 ft (9.4 m)	48 ft (14.6 m) 23 ft (7 m)
2	Rigid metal Flexible metal	44 ft (13.4 m) 27 ft (8.2 m)	38 ft (11.6 m) 19 ft (5.8 m)
3	Rigid metal Flexible metal	35 ft (10.7 m) 25 ft (7.6 m)	29 ft (8.8 m) 17 ft (5.2 m)
4	Rigid metal Flexible metal	27 ft (8.2 m) 23 ft (7 m)	21 ft (6.4 m) 15 ft (4.6 m)

NOTE: Side and bottom exhaust installations have a 90° turn inside the dryer. To determine maximum exhaust length, add one 90° turn to the chart.

Recommended hood styles

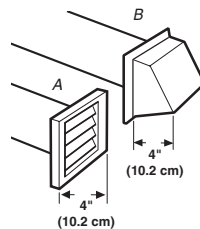

A. Louvered hood style
B. Box hood style

Angled hood style is acceptable.

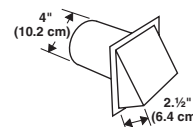

Select the route that will provide the straightest and most direct path outdoors. Plan the installation to use the fewest number of elbows and turns. Use the fewest 90° turns possible.

Do not use vent runs longer than specified in vent length chart.

Determine the number of elbows you will need.