



# Large Capacity Thin Twin Washer • Dryer – 120/240 Volt Installation Instructions

**IMPORTANT:  
Read and save  
these instructions.**

**IMPORTANT:**

**Installer:** Leave Installation Instructions with the homeowner.

**Homeowner:** Keep Installation Instructions for future reference.

**Save** Installation Instructions for local electrical inspector's use.

[www.whirlpool.com](http://www.whirlpool.com)

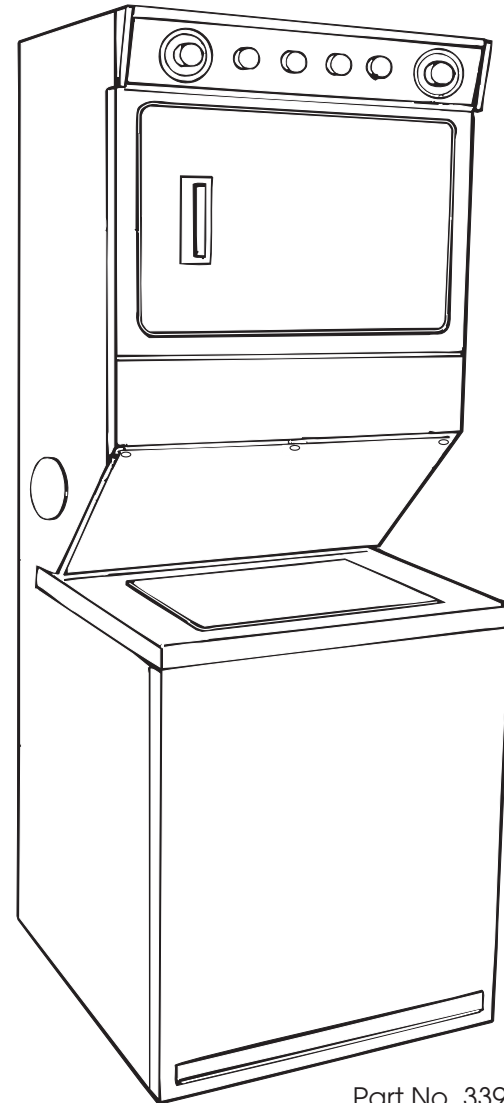

Part No. 3397616 Rev. B

# Before you start...

**Your safety and the safety of others are very important.**

We have provided many important safety messages in this manual and on your appliance. Always read and obey all safety messages.



This is the safety alert symbol.

This symbol alerts you to potential hazards that can kill or hurt you and others.

All safety messages will follow the safety alert symbol and either the word "DANGER" or "WARNING". These words mean:

## DANGER

**You can be killed or seriously injured if you don't immediately follow instructions.**

## WARNING

**You can be killed or seriously injured if you don't follow instructions.**

All safety messages will tell you what the potential hazard is, tell you how to reduce the chance of injury, and tell you what can happen if the instructions are not followed.

**Do Not store or operate washer/dryer below 32°F (some water may remain in washer). Proper operation of dryer cycles requires temperatures above 45°F. See Use & Care Guide for "Winterizing" information.**

**Check code requirements:** Some codes limit or do not permit installation of clothes dryers in garages, closets, mobile homes and sleeping quarters. Contact your local building inspector.

**Check utilities:** Proper, water and electrical supply connections **must** be available.

## WARNING



### Explosion Hazard

**Keep flammable materials and vapors, such as gasoline, away from dryer.**

**Failure to do so can result in death, explosion, or fire.**

Check location where washer/dryer will be installed. Proper installation is your responsibility. The washer/dryer must not be installed or stored in an area where it will be exposed to water and/or weather. Make sure you have everything necessary for correct installation.

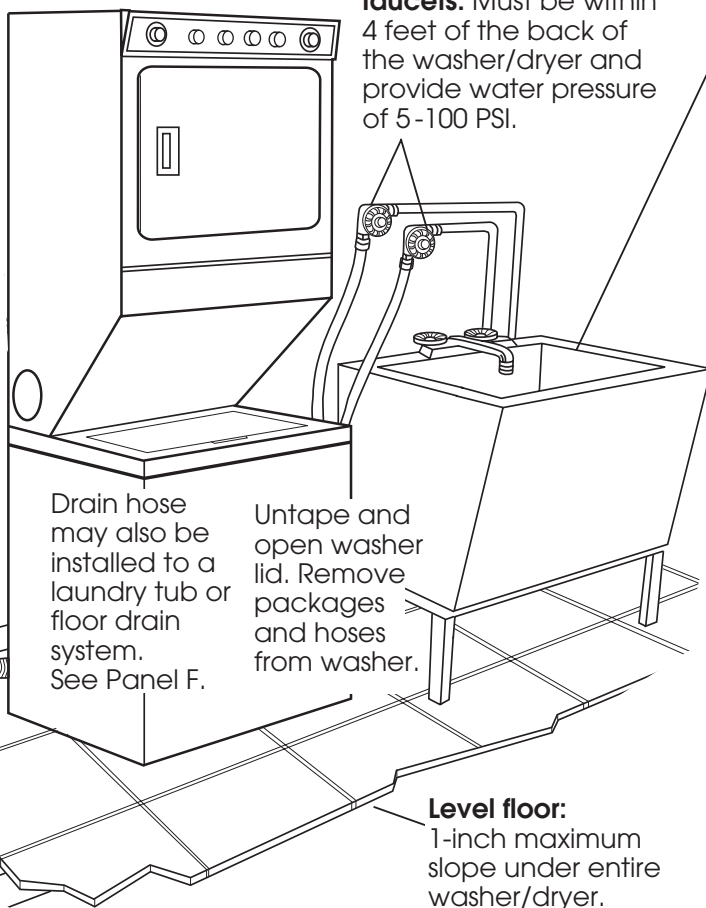

**Location:** Should be large enough to fully open dryer door to 90°. See Panel G for "Recessed and closet installation instructions" and "Product dimensions."

**Grounded electrical connection** is required. See "Electrical requirements."

**Standpipe drain system:** Needs a two-inch diameter standpipe with minimum carry-away capacity of 17 gallons per minute. Top of standpipe must be at least 34 inches high and no higher than 72 inches from floor.

**Floor drain system** requires a siphon break, Part No. 285320, available from a Whirlpool-authorized parts distributor.

**Support:** Floor must be sturdy enough to support washer/dryer weight, with water and clothes, of 500 pounds.

## Tools and materials needed for installation:

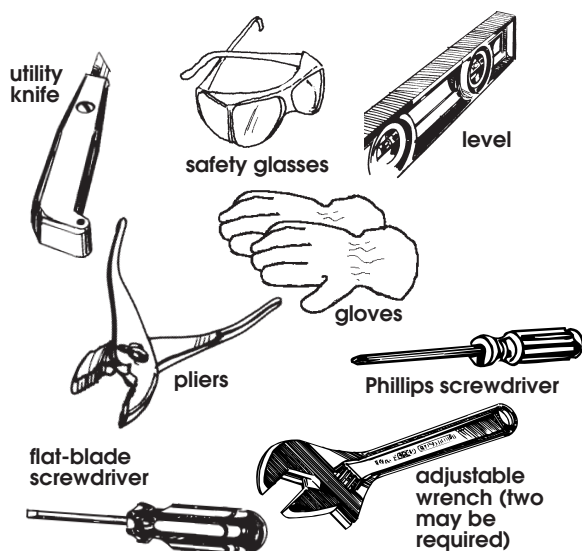

## WARNING



**Electrical Shock Hazard**  
**Plug into a grounded 4-prong outlet.**  
**Failure to do so can result in death or electrical shock.**

## Electrical requirements

A four-wire or three-wire, single-phase, 120/240-volt, 60-Hz, AC-only electrical supply (or four-wire or three-wire, 120/208-volt, if specified on the model/serial rating plate) is required on a separate, 30-ampere circuit, fused on both sides of the line. A time-delay fuse or circuit breaker is recommended. The model/serial rating plate is located in the door well behind the dryer door on the front of the opening.

It is the personal responsibility and obligation of the customer to contact a qualified electrician to assure that the electrical installation is adequate and in conformance with the National Electrical Code, ANSI/NFPA 70 — latest edition\*, and all local codes and ordinances.

Copies of the standards listed above may be obtained from:

\* National Fire Protection Association  
Batterymarch Park  
Quincy, Massachusetts 02269

## Power supply cord

Local codes may permit the use of a U.L.-listed, 120/240-volt minimum, 30-ampere, dryer power supply cord kit (pigtail). Power supply cord should be Type SRD or SRDT and be at least four feet long. The wires that connect to the dryer must end with ring terminals or spade terminals with upturned ends. A 3/4", U.L.-listed strain relief must be installed where the power supply cord connects to the dryer (see Figures 1 and 2).

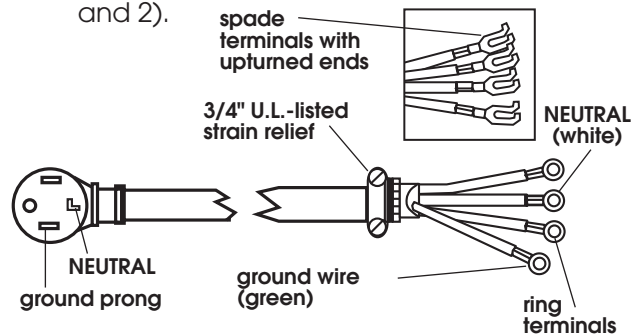

**Four-wire power supply cord**  
**NEMA 14-30P**  
**Figure 1**

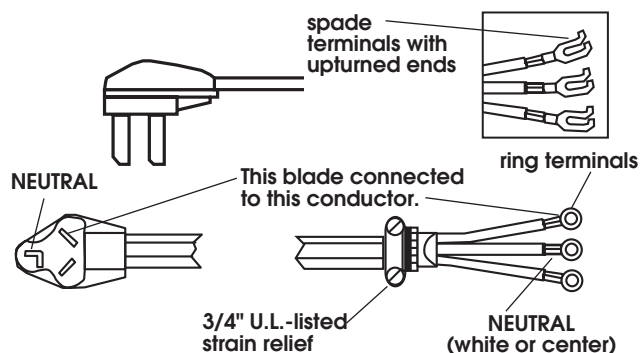

**Three-wire power supply cord**  
**NEMA 10-30P**  
**Figure 2**

For use where local codes permit use of flexible power supply cord.

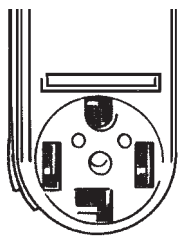

four-wire receptacle(14-30R)

Figure 3



three-wire receptacle(10-30R)

Figure 4

**Four-wire installation is recommended (required for mobile homes):** The power supply cord must have four, No.-10 copper wires and match a four-wire receptacle of NEMA Type 14-30R (see Figure 3). The fourth wire (ground conductor) must be identified with a green cover and the neutral conductor by a white cover.

**Three-wire installation (if a four-wire system is not available):** The power supply cord must have three, No.-10 copper wires to match a three-wire receptacle of NEMA Type 10-30R (see Figure 4).

### Direct wire

The washer/dryer can be connected directly to fused disconnect or circuit breaker box with four-wire or three-wire flexible armored or non-metallic sheathed copper cable (with ground wire). Do Not use two-wire with bare ground wire. All current-carrying wires must be insulated.

A conduit connector must be installed at junction box. USE ONLY 10-GAUGE SOLID COPPER WIRE. DO NOT USE ALUMINUM WIRE. Allow four feet of slack in the line so dryer can be moved if servicing is ever necessary.

## Electrical connection

This dryer is manufactured with the cabinet-ground conductor connected to the NEUTRAL (center) of the wiring harness at the terminal block. If local codes do NOT permit this type of connection, use "Four-wire connection" instructions.

**GROUND INSTRUCTIONS:** This appliance must be grounded. In the event of malfunction or breakdown, ground will reduce the risk of electric shock by providing a path of least resistance for electric current.

If using a power supply cord, the plug must be plugged into an appropriate outlet that is properly installed and grounded in accordance with all local codes and ordinances.

If using a direct wire connection, this appliance must be connected to a grounded metal, permanent wiring system; or an equipment-ground conductor must be run with the circuit conductors and connected to the equipment-ground terminal or lead on the appliance.

**WARNING -** Improper connection of the equipment-ground conductor can result in a risk of electric shock. Check with a qualified electrician or serviceman if you are in doubt as to whether the appliance is properly grounded. Do not modify the power supply cord plug. If it will not fit the outlet, have a proper outlet installed by a qualified electrician.

If the house has aluminum wiring, follow the procedure below:

- Connect a section of 8 gauge solid copper wire to the connector block.
- Connect the aluminum wiring to the added section of copper wire using special connectors designed and Underwriters Laboratories Listed for joining copper to aluminum. Follow the electrical connector manufacturer's recommended procedure.
- Aluminum/copper connection must conform with local codes and industry accepted wiring practices.

# A.

## Four-wire connection...

### ⚠ WARNING



#### Fire Hazard

Use a new UL approved 30 ampere power supply cord.  
Use a UL approved strain relief.  
Disconnect power before making electrical connections.  
Connect neutral wire (white or center wire) to center terminal (silver).  
Ground wire (green or bare wire) must be connected to green ground connector.  
Connect remaining 2 supply wires to remaining 2 terminals (gold).  
Securely tighten all electrical connections.  
Failure to do so can result in death, fire, or electrical shock.

### ⚠ WARNING



#### Fire Hazard

Use 10 gauge solid copper wire.  
Use a UL approved strain relief.  
Disconnect power before making electrical connections.  
Connect neutral wire (white or center wire) to center terminal (silver).  
Ground wire (green or bare wire) must be connected to green ground connector.  
Connect remaining 2 supply wires to remaining 2 terminals (gold).  
Securely tighten all electrical connections.  
Failure to do so can result in death, fire, or electrical shock.

## POWER SUPPLY CORD

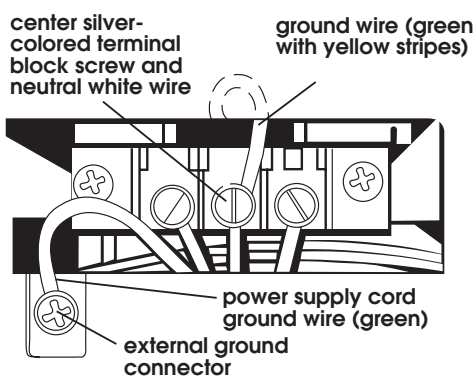
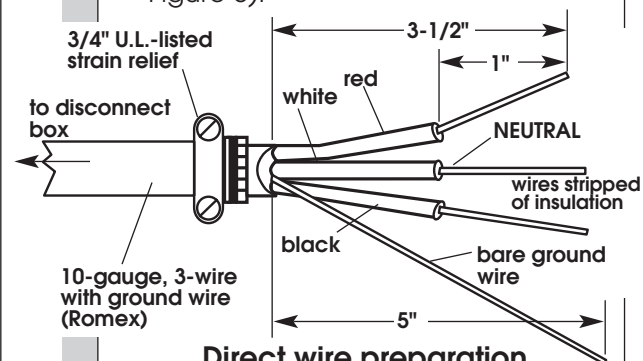

Figure 5

- Disconnect the power supply.
- Remove terminal block cover.
- Install copper, four-wire power supply cord through strain relief.
- Remove the ground wire (green with yellow stripes) from the external ground connector and fasten under center, silver-colored terminal block screw.
- Connect the ground wire (green) of the copper, four-wire power supply cord to the external ground connector.
- Connect the neutral wire (white) of the power supply cord to the center, silver-colored terminal screw of the terminal block. Connect the other wires to the outer terminals. Tighten screws firmly.
- Tighten strain relief screws.
- Replace the terminal block cover.

## DIRECT WIRE

- Disconnect the power supply.
- Remove terminal block cover.
- Strip 5 inches of outer covering from end of cable. Leave bare ground wire at 5 inches. Cut 1-1/2 inches from 3 remaining insulated wires. Strip insulation back 1 inch (see Figure 6).



### Direct wire preparation

Figure 6



Figure 7

Shape the end of each wire into a "U" shaped hook (see Figure 7). The bare ground wire must be 4-1/2" long after forming the hook.

- Install copper, four-wire power supply cable through strain relief.
- Remove the ground wire (green with yellow stripes) from the external ground connector and fasten under center, silver-colored terminal block screw.
- Slide the hook end of the ground wire (bare) of the four-wire power supply cable under the external ground connector screw. Squeeze hook end of wire together. Tighten screw.
- Connect the neutral wire (white) of the power supply cable to the center, silver-colored terminal screw of the terminal block using the same method. Connect the other wires to the outer terminals. Tighten screws firmly.
- Tighten strain relief screws.
- Replace the terminal block cover.



# B.

## Three-wire connection...

Where local codes permit connecting cabinet-ground conductor to the neutral wire:

### ⚠ WARNING



#### Fire Hazard

- Use a new UL approved 30 ampere power supply cord.
- Use a UL approved strain relief.
- Disconnect power before making electrical connections.
- Connect neutral wire (white or center wire) to center terminal (silver).
- Ground wire (green or bare wire) must be connected to green ground connector.
- Connect remaining 2 supply wires to remaining 2 terminals (gold).
- Securely tighten all electrical connections.
- Failure to do so can result in death, fire, or electrical shock.

Where local codes permit connecting cabinet-ground conductor to the neutral wire of the power supply cable:

### ⚠ WARNING



#### Fire Hazard

- Use 10 gauge solid copper wire.
- Use a UL approved strain relief.
- Disconnect power before making electrical connections.
- Connect neutral wire (white or center wire) to center terminal (silver).
- Ground wire (green or bare wire) must be connected to green ground connector.
- Connect remaining 2 supply wires to remaining 2 terminals (gold).
- Securely tighten all electrical connections.
- Failure to do so can result in death, fire, or electrical shock.

## Exhaust requirements

### ⚠ WARNING



#### Fire Hazard

- Use a heavy metal vent.
- Do not use a plastic vent.
- Do not use a metal foil vent.
- Failure to do so can result in death or fire.

Important: Observe all governing codes and ordinances.

It is recommended that you exhaust your dryer to the outside for best performance. Moisture and lint indoors may cause:

- Lint to gather around the dryer where it can be fuel for a fire.
- Moisture damage to woodwork, furniture, paint, wallpaper, carpet, etc.
- Housecleaning problems and health problems.

If the washer/dryer is installed in a confined area such as a bedroom, bathroom or closet, it must be exhausted to the outside and provision must be made for enough air for ventilation. Check governing codes and ordinances. Also refer to the "Recessed and closet installation instructions" on Panel G.

**Dura Safe™ vent products are recommended and are available from your dealer. See Panel G.**

**Four-inch diameter vent is required.**

**Use a heavy metal vent.** Do not use plastic or metal foil vent.

- Do Not use non-metal flexible vent, or exhaust hoods with magnetic latches.
- Do Not exhaust dryer into a chimney, furnace, cold air vent, attic or crawl space, or any other vent used for venting.
- Do Not install flexible vent in enclosed walls, ceilings or floors.

**Rigid metal vent is recommended** to prevent crushing and kinking.

**Flexible metal vent** must be fully extended and supported when the dryer is in its final position.

Remove excess flexible vent to avoid sagging and kinking that may result in reduced air flow.

**An exhaust hood** should cap the exhaust vent to prevent rodents and insects from entering the home.

**Exhaust outlet hood** must be at least 12 inches from the ground or any object that may be in the path of the exhaust (such as flowers, rocks or bushes, etc.).

**If using an existing exhaust system, clean lint from entire length of system and make sure exhaust hood is not plugged with lint.**

Replace any plastic or metal foil vent with rigid metal or flexible metal vent.

**Use clamps** to seal all joints. Do not use duct tape, screws or other fastening devices that extend into the interior of the vent to secure vent.

**Service check:** Back pressure in any exhaust system used must not exceed 0.6 inches in water column measured with an incline manometer at the point that exhaust vent connects to dryer.

## POWER SUPPLY CORD

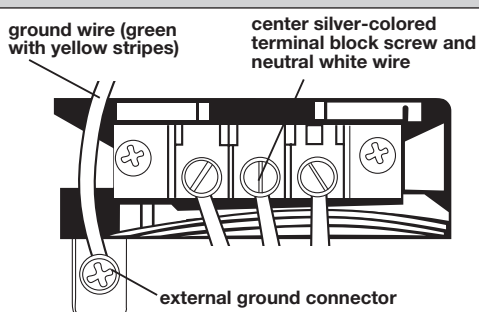
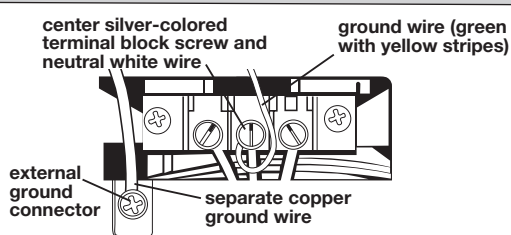

Figure 8

1. Disconnect the power supply.
2. Remove terminal block cover.
3. Install copper three-wire power supply cord through strain relief.
4. Remove the ground wire (green with yellow stripes) from under center, silver-colored terminal block screw and connect to external ground connector (see Figure 8).
5. Connect the neutral wire (white or center) of the power supply cord to the center, silver-colored terminal screw of the terminal block. Connect the other wires to the outer terminals. Tighten screws firmly.
6. Tighten strain relief screws.
7. Replace the terminal block cover.

Where local codes DO NOT permit connecting the cabinet-ground conductor to the neutral (white) wire:

## POWER SUPPLY CORD OR DIRECT WIRE



Connect separate copper ground wire from external ground connector to approved ground.

Figure 12

1. Disconnect the power supply.
2. Remove terminal block cover.
3. Install solid copper, power supply cord or cable through strain relief.
4. Remove the ground wire (green with yellow stripes) from the external ground connector.
5. Connect the ground wire (green with yellow stripes) and the neutral (white) wire of the power supply cord or direct wire cable to the center, silver-colored terminal screw of the terminal block. Connect the other wires to the outer terminals. Tighten screws (see Figure 12).

## DIRECT WIRE

1. Disconnect the power supply.
2. Remove terminal block cover.
3. Strip 3-1/2 inches of outer covering from end of cable. If using three-wire cable with 1 wire, cut the bare wire even with outer covering. Strip 1 inch of insulation from the end of each insulated wire (see Figure 9).

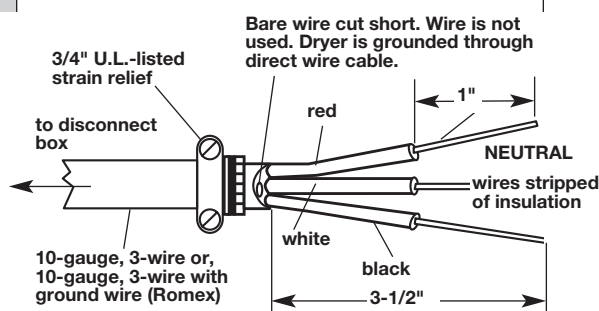

Direct wire preparation  
Figure 9



Figure 10

Shape the end of each wire into a "U" shaped hook (see Figure 10).

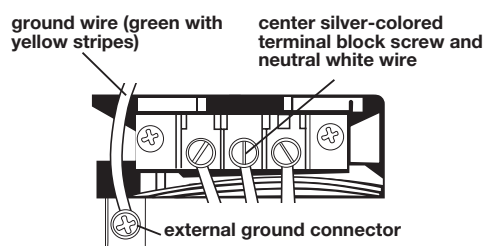
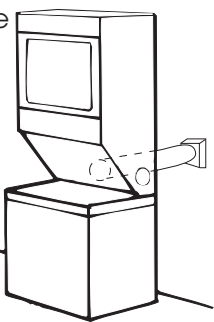

Figure 11

4. Install copper, three-wire power supply cable through strain relief.
5. Remove the ground wire (green with yellow stripes) from under center, silver-colored terminal block screw and connect to external ground connector (see Figure 11).
6. Slide the hook end of the neutral (white or center) wire from the three-wire power supply cable under the center, silver-colored terminal screw of the terminal block. Squeeze the hook end of the wire together. Tighten screw.
7. Connect the other wires to the outer terminals using the same method. Tighten screws firmly (see Figure 11).
8. Tighten strain relief screws.
9. Replace the terminal block cover.

6. Connect a separate copper ground wire (No.-10 minimum) from the external ground screw to an adequate ground.
7. Tighten strain relief screws.
8. Replace the terminal block cover.

The **exhaust vent** can be routed up, down, left, right or straight out the back of the washer/dryer. Space requirements are provided on Panel G and on the rear panel of the washer/dryer. Use the straightest path you can, to avoid 90° turns.



**Maximum length** of the exhaust system depends upon the type of vent used, number of elbows and the type of exhaust hood. The maximum length for both rigid and flexible vent is shown in the chart.

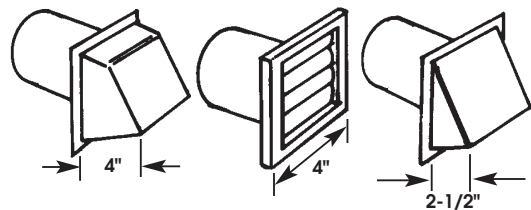

Rear, Side or Bottom Exhaust		
Number of 90° turns	Maximum length of vent	Four-inch diameter vent
0	42 ft	rigid metal vent
1	34 ft	
2	26 ft	
0	26 ft	flexible metal vent
1	21 ft	
2	16 ft	

The maximum length using a 2" x 6" rectangular vent with 2 elbows and a 2-1/2" (TYPE C) exhaust hood is 8 ft.

For exhaust systems not covered by the exhaust length chart, see [Service Manual](#), Part No. 603197, available from a Whirlpool-authorized parts distributor.

**Four-inch exhaust hood is preferred.**

However, a 2-1/2-inch exhaust hood may be used. A 2-1/2-inch exhaust hood creates greater back pressure than other hood types. **For permanent installation, a stationary exhaust system is required.**

**Exhausting the dryer through the side** of the washer/dryer requires the use of Side Exhaust Kit, Part No. 279823, available from a Whirlpool-authorized parts distributor. Follow kit Installation Instructions for proper exhaust installation.

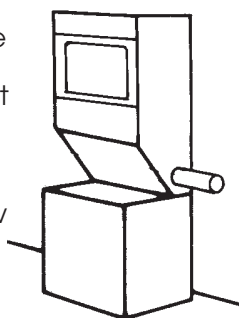

## Mobile home installation

This washer/dryer is suitable for mobile home installations. The installation of the washer/dryer must conform to the **Manufactured Home Construction and Safety, Title 24 CFR, Part 3280 (formerly the Federal Standard for Mobile Homes Construction and Safety, Title 24, HUD Part 280, latest edition).**

### Mobile home exhaust requirements:

The washer/dryer must have an outside exhaust. If the dryer is exhausted through the floor and the area under the mobile home is enclosed, the exhaust system **must** terminate outside the enclosed area. Extension beyond the enclosure will prevent lint and moisture buildup under the mobile home.

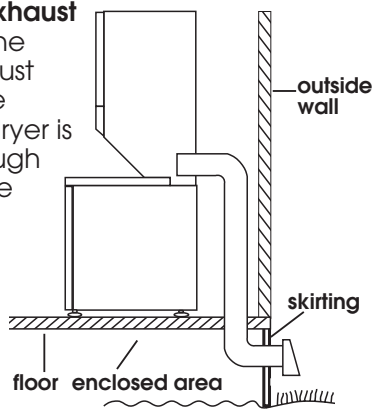

## Panel D

## Now start... with washer/dryer in laundry area.

### ⚠ WARNING

#### Excessive Weight Hazard

Use two or more people to move and install washer/dryer.

Failure to do so can result in back or other injury.

Truck only from rear to prevent product damage.

**1.** Put on safety glasses and gloves.

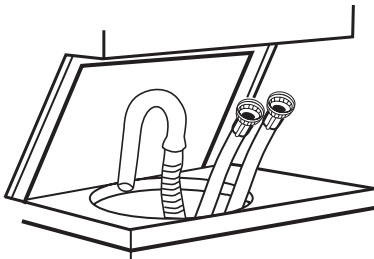

**2.** Open washer lid. Take hoses and parts packages out of basket. Close lid.

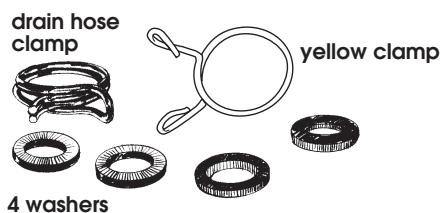

**3.** Remove parts from package. Check that all parts were included.

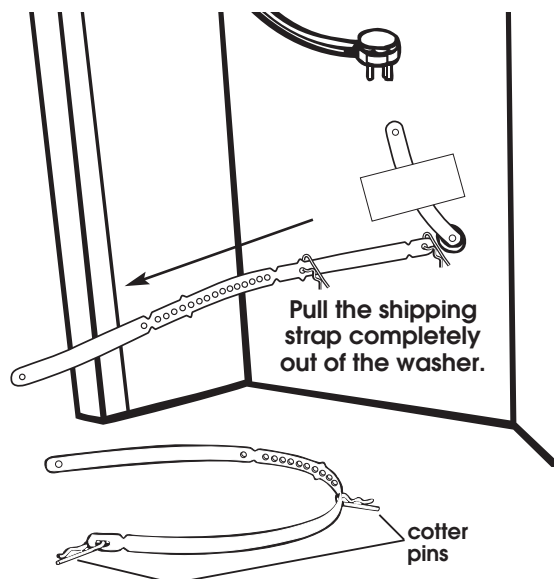

**4.** Pull to completely remove the shipping strap with 2 coter pins from the inside of the washer/dryer.

Save the shipping strap for use in Step 18.

**5.** Tilt washer/dryer forward. Check that rear leveling legs move up and down freely so that washer/dryer can be properly leveled in Step 15.

**6.** Disconnect the power supply. Connect power supply cord or cable to dryer. See "Electrical connection," Panels B and C. Do Not plug power supply cord into outlet or reconnect power at this time.

**Use new hoses and washers that came with your washer/dryer.**

Replace inlet hoses after 5 years of use to reduce the risk of hose failure. Inspect and replace inlet hoses if bulges, kinks, cuts, wear, or leaks are found. When replacing your inlet hoses, mark the date of replacement on the label with a permanent marker.

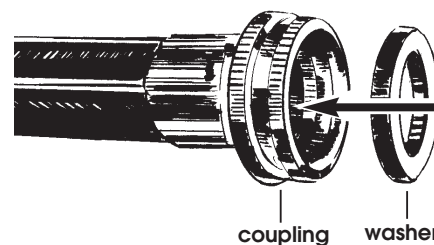

**7.** Insert a flat washer into **each** end of the inlet hoses. Check that washers are firmly seated in couplings.

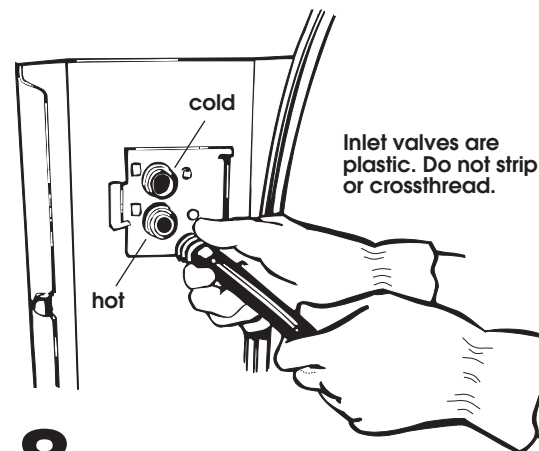

**8.** Attach hose to bottom (hot water) inlet valve opening first; then second hose to top (cold water) inlet valve. Tighten couplings by hand. Use pliers to make an additional two-thirds turn.

**IMPORTANT: THIS PROCEDURE MUST BE FOLLOWED TO ASSURE PROPER INSTALLATION.**

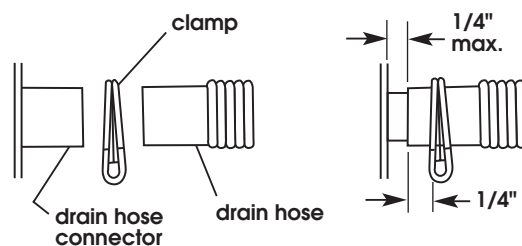

**9.** To prevent the drain hose from coming off or leaking, it must be installed per the following instructions:

1. Wet the inside end of the drain hose with tap water. **DO NOT USE ANY OTHER LUBRICANT.**
2. Squeeze ears of drain hose clamp with pliers to open and place clamp over the end of the drain hose.
3. While holding clamp open, work end of drain hose onto drain connector.
4. Position clamp over the drain hose area marked "clamp." Release clamp. Clamp should be 1/4 inch from end of drain hose.



**10.** Standpipe or laundry tub drain system: Open yellow clamp and slide over "hook" end of drain hose to secure the rigid and corrugated sections together.

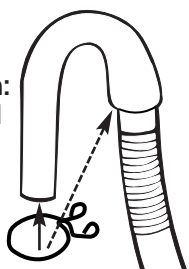

**Floor drain system:** Do Not install "hook" end of drain hose to corrugated section. Consult your plumber for proper installation.

**Slide washer/dryer onto cardboard or hardboard before moving across floor to avoid damaging floor covering.**

**11.** If you have room to work from either side of the washer/dryer, move washer/dryer close to final position so you can easily complete the following steps. (Go to Step 12.)

**If you are working in a closet or recessed area,** move the washer/dryer into final position and remove cardboard or hardboard from under washer/dryer. Remove the access panel by removing three Phillips-head screws and one bumper, located at the top of the access panel. Set panel, screws and bumper aside. Complete the following steps through the access area.

**12.** Put "hook" end of drain hose into laundry tub or standpipe. Check for proper length of drain hose.

**13.** Before attaching water inlet hoses, run water through both faucets into a bucket. This will get rid of particles in water lines that might clog hoses. Mark which is the hot water faucet.

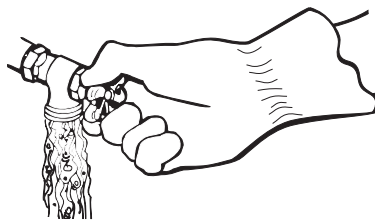

Replace inlet hoses after 5 years of use to reduce the risk of hose failure. Inspect and replace inlet hoses if bulges, kinks, cuts, wear, or leaks are found. When replacing your inlet hoses, mark the date of replacement on the label with a permanent marker.

**14.** Attach bottom inlet hose (inlet marked "H") to hot water faucet. Attach top inlet hose (inlet marked "C") to cold water faucet. Tighten couplings to the faucets by hand. Use pliers to make final two-thirds turn.

**Move washer/dryer to its permanent location. Remove cardboard/hardboard from under washer/dryer.**

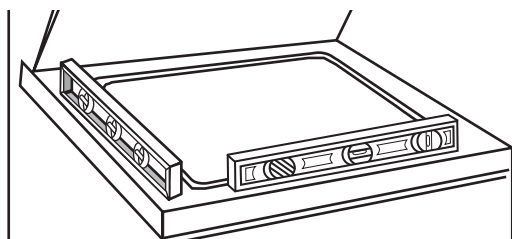

**15.** Carefully move the washer/dryer into final position. Tilt washer/dryer forward raising back legs 1 inch off of floor to adjust rear, self-leveling legs. Gently lower washer/dryer to floor. Check levelness of the washer/dryer by placing a carpenter's level on top of the washer, first side to side; then front to back. If washer/dryer is not level, check that rear leveling legs move up and down freely. If washer/dryer is level, go to Step 17.



Insert corner posts 6 inches from left leg. Do Not insert corner posts in the center of the washer/dryer.

**16.** If washer/dryer is not level, carefully tilt washer/dryer backward until front of washer/dryer is 3-4 inches off of floor. Insert 4 corner posts under washer/dryer about 6 inches from the left leg. Loosen nuts on each front leg. Adjust the front legs up or down. Tilt washer/dryer backward and remove corner posts. Gently lower the washer/dryer to the floor. Repeat Step 15 and 16 until washer/dryer is level.

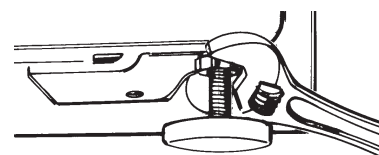

**17.** When washer/dryer is level, use adjustable wrench to turn nuts on front legs up tightly against washer/dryer base. If nuts are not tight against washer/dryer base, the washer/dryer may vibrate.

**Secure the drain hose to the laundry tub or standpipe with the shipping strap removed from the back of the washer.**

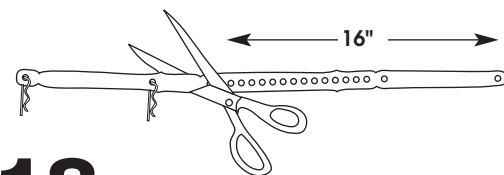

**18.** After shipping strap has been removed (Step 4), look for the words "cut here" marked on the shipping strap, about 16 inches from plug end. Cut the shipping strap at this mark. Pull shipping strap out of the power supply cord.

11. 20. 28.

15.

6. 23. 30.

21. 22.

7. 8.

9.

12. 19.

10.

7.

14.

4. 18. 19.

Pull shipping strap with 2 cotterpins completely out of washer.

Numbers correspond to steps.

Check that hose is not twisted or kinked and is securely in place.

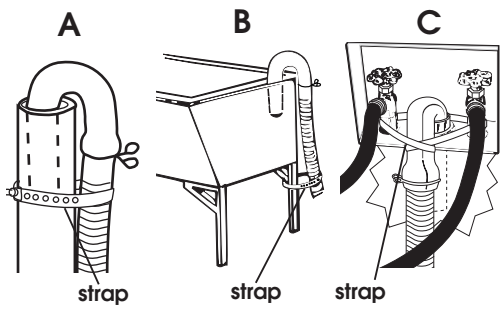

**19.** Put “hook” end of drain hose in laundry tub or standpipe. Tightly wrap the shipping strap around the drain hose and laundry tub or standpipe as shown in Figures A and B. Push plug into the nearest hole in the shipping strap.

If the water inlet faucets and drain standpipe are recessed, put “hook” end of drain hose in standpipe. Tightly wrap the shipping strap around the drain hose and faucet body (not the handles or stems) as shown in Figure C. Push plug into the nearest hole in the shipping strap.

**Hose must be cut exactly to length so “hook” end is held tightly over edge of standpipe.**

If drain hose cannot be strapped in place, it must be cut exactly to length so the “hook” end is held tightly over the edge of the tub or standpipe. See Figure D.

If a longer drain hose is needed, drain hose (Part No. 388423) and hose extension kit (Part No. 285442) are available from a Whirlpool-authorized parts distributor. If drain hose must be shortened, use hose kit (Part No. 285442).

**Note: If washer/dryer is moved to adjust drain hose, the washer/dryer must be leveled again. Repeat Steps 15-17. Place cardboard under the washer/dryer and carefully move washer/dryer to avoid damaging floor covering.**

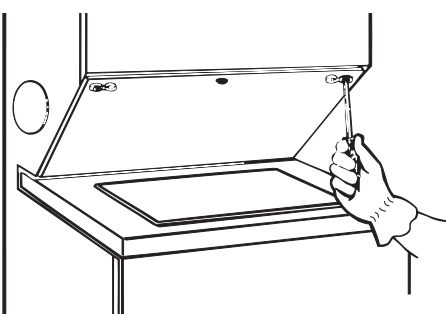

**20.** If you did not remove the access panel in Step 11, remove three Phillips-head screws and one bumper, located at the top of the access panel. Set the panel, screws and bumper aside.

**21.** Determine the length of exhaust vent that is needed to connect the dryer to the exhaust hood. (See “Exhaust requirements,” Panels C and D.)

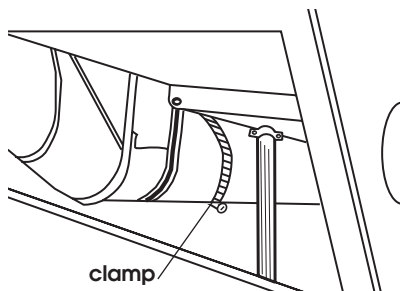

**22.** Connect exhaust vent to washer/dryer and then to the exhaust hood.

- Use the straightest path possible to avoid 90° turns.
- Use clamp to seal all joints in the exhaust system.
- Use caulking compound to seal exterior wall opening around exhaust hood.

**23. CHECK ELECTRICAL REQUIREMENTS. BE SURE YOU HAVE CORRECT ELECTRICAL SUPPLY AND RECOMMENDED GROUND METHOD.** Check the Installation Instructions to see that you have completed each step. Complete any missed steps before you continue.

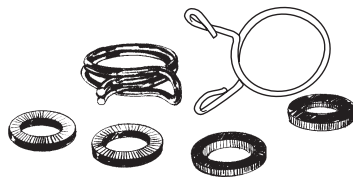

**24.** Check that all parts are now installed. See parts list, Panel D. If there is an extra part, go back through steps to see which step was skipped.

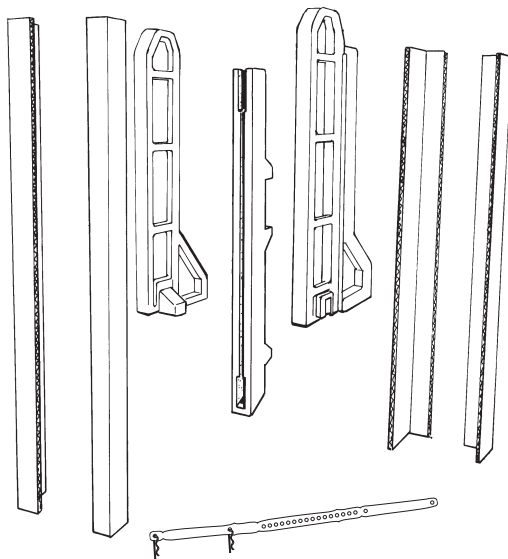

**25.** Check that you removed all the shipping pieces including the shipping strap with its 2 cotterpins and plug. Dispose of all materials in proper manner.

**If you do not remove the shipping strap, your washer/dryer may “walk” away from its location.**

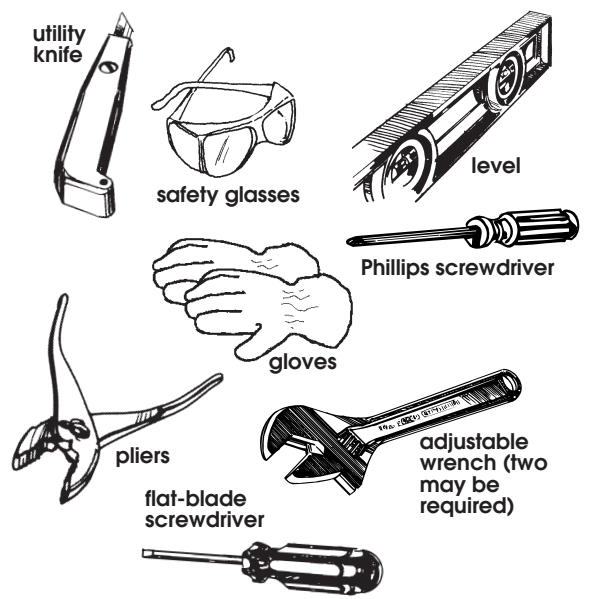

**26.** Check that you have all of your tools.

**27.** Turn on water faucets and check for leaks. Tighten couplings if there is leaking. **Do Not overtighten;** this could cause damage to faucet.

**28.** Replace access panel. Be sure to tighten the three Phillips-head screws at the top of the access panel. Replace the bumper under the center screw.

**29.** Read the *Use and Care Guide* to fully understand your new washer/dryer. Open dryer door. Check to be sure lint screen is in its proper position. Wipe out drum.

**30.** Plug power supply cord into grounded outlet. Reconnect the power supply. Now start the washer and allow it to complete the regular cycle.

**31.** Start dryer and allow it to complete a full heat cycle to make sure it is working properly.

You have successfully installed your new Whirlpool washer/dryer. To get the most efficient use from your new Whirlpool washer/dryer, read your *Use and Care Guide*.

**Congratulations!**

Keep Installation Instructions nearby where you can refer to them. They'll make reinstalling your Whirlpool washer/dryer in another home as easy as the first installation.

# Recessed and closet installation instructions

This washer/dryer may be installed in a recessed area or closet.

The installation spacing is in inches and is minimum allowable. Additional spacing should be considered for ease of installation, servicing and compliance with local codes and ordinances.

If closet door is installed, the minimum unobstructed air openings in top and bottom are required. Louvered doors with equivalent air openings are acceptable. Closet installation must be exhausted.

Other installations must use the minimum dimensions indicated.

## Recessed area minimum installation spacing

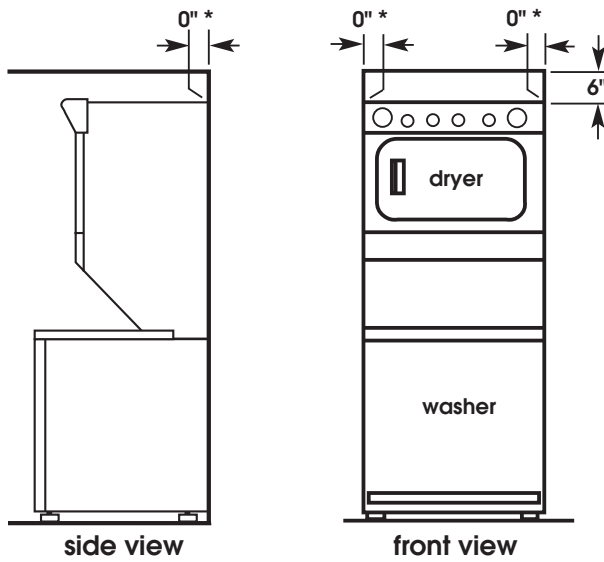

Recessed, non-exhausted installation must use only the rear exhaust position and Exhaust Deflector Part No. 694609.  
 Note: If recessed installation is exhausted to the side or rear, 6" must be available above the washer/dryer but all other spacing can be 0".

## Product dimensions

Most installation will require at least 5 inch clearance behind the dryer for the dryer vent. Location must be large enough to fully open dryer door.

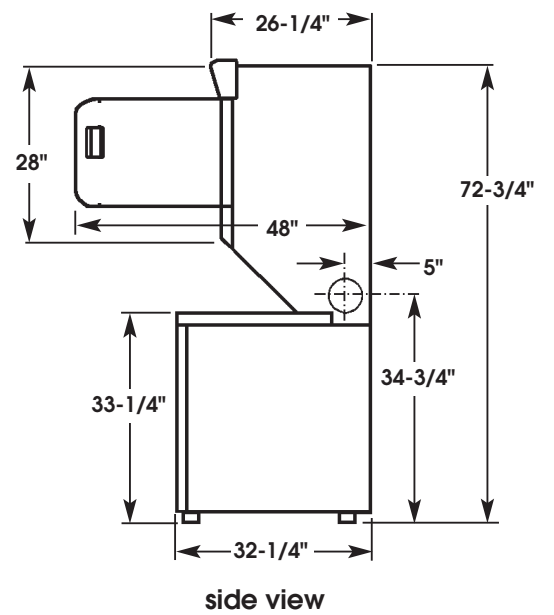

## Closet installation must be exhausted outdoors.

WARNING - To reduce the risk of fire, this appliance MUST BE EXHAUSTED OUTDOORS.

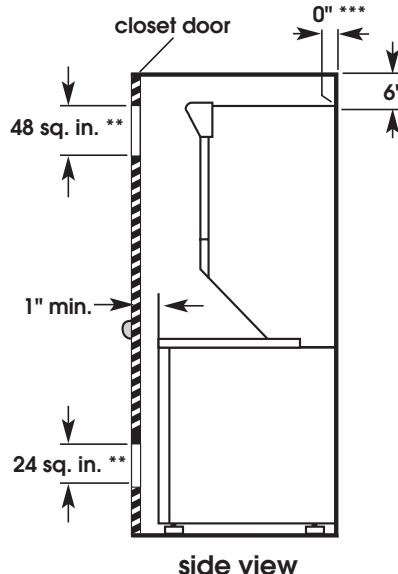
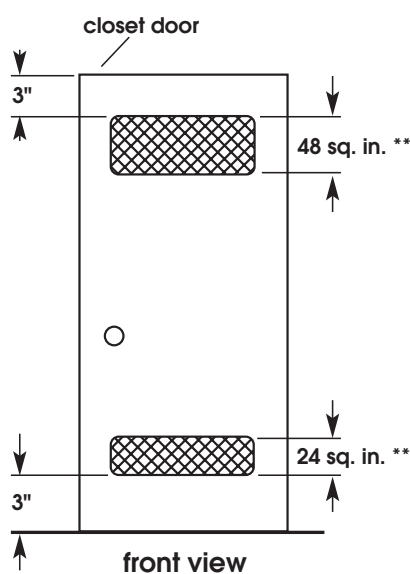

\* Additional clearances for wall, door and floor moldings may be required or if external exhaust elbow is used.  
 \*\* Opening is minimum for closet door. Louvered door with equivalent air openings is acceptable.  
 \*\*\* Additional space may be needed for exhaust elbow.

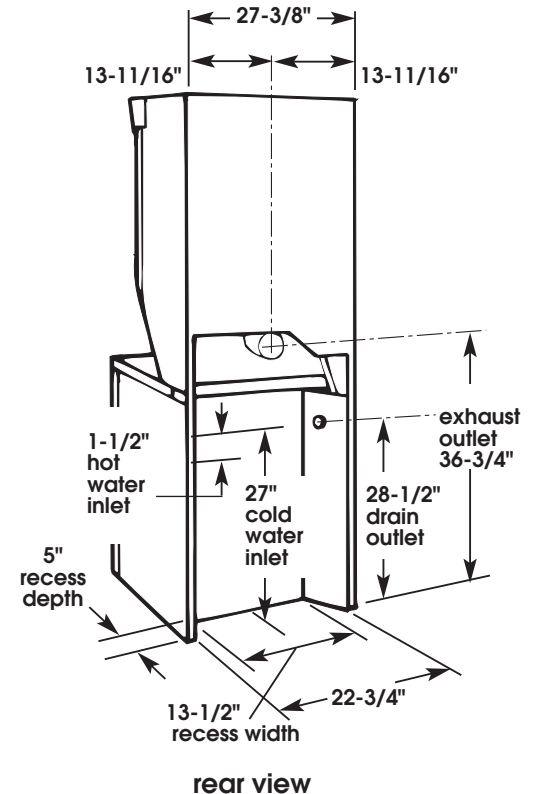

## CRUSH RESISTANT Dura Safe™ SURE CONNECT™ Vent Kit

Kits Make Installation Easy

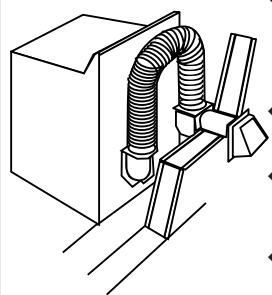

- ◆ Provides 4 1/2" clearance between dryer and wall
- ◆ Snap-Lock fittings
- ◆ Total kit length 8 feet
- ◆ Additional vent can be snapped between sections for longer runs

Kit Contains:

- 2- 4' vent sections with attached close elbows
- 1- Wall plate for close clearance installations
- 2- 4" clamps

"As easy as 1-2-3"

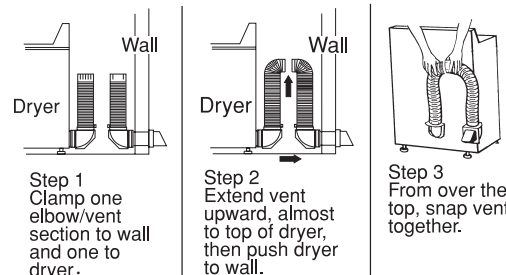

Dura Safe and Sure Connect are Trademarks of Whirlpool, U.S.A.

## Periscopes For Offset Outlets, Tight Installations

- ◆ Provides 2 1/2" clearance between dryer and wall
- ◆ Great for closet installations
- ◆ 0"-18", 18"-29" or 29"-50" periscopes include one male snap-lock fitting, one extra long draw-band collar and one clamp

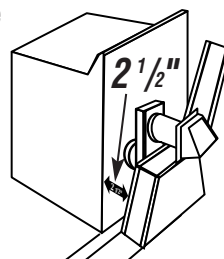

0"-18" : Part #4396037  
 18"-29" : Part #4396011  
 29"-50" : Part #4396014

### 0"-18" Periscope

- ◆ Use when vent outlets overlap or are offset
- ◆ Excess length can be trimmed to fit

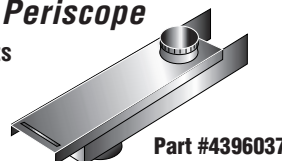

### 18"-29" and 29"-50" Periscope

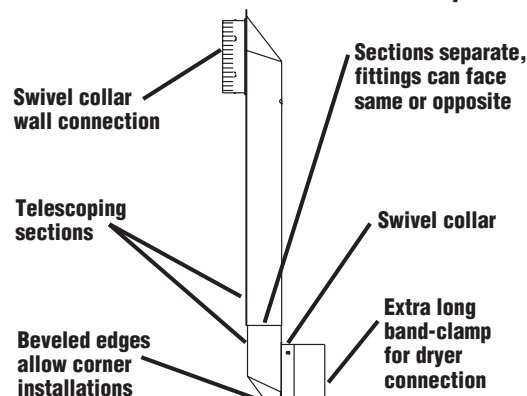

18"-29" : Part #4396011      29"-50" : Part #4396014

For more information, or to easily place your order, call

**1-800-442-9991**

To have your venting professionally installed, call

**1-800-253-1301**

for the nearest authorized service provider.



## If washer/dryer does not operate properly...

Check the following to be sure that:

1. Electrical supply is connected.
2. House fuse or circuit breaker is intact and tight.
3. Washer lid or dryer door is closed.
4. Controls are set in a running or "ON" position.
5. Dryer start button has been firmly pushed.
6. Make sure shipping strap has been completely removed and was used to secure the drain hose to the laundry tub or standpipe.

## If you need assistance...

The Whirlpool Customer Interaction Center will answer any questions about operating or maintaining your washer/dryer not covered in the Installation Instructions. The Whirlpool Customer Interaction Center is open 24 hours a day, 7 days a week. Just dial 1-800-253-1301 — the call is free.

When you call, you will need the washer/dryer model number and serial number. Both numbers can be found on the model/serial rating plate located in the door well behind the dryer door on front of opening.

## If you need service...

In the event that your Whirlpool appliance should need service, call the dealer from whom you purchased the appliance or a Whirlpool-authorized service company. A Whirlpool-authorized service company is listed in the Yellow Pages of your telephone directory under "Appliances — Household — Major — Service and Repair." You can also obtain the service company's name and telephone number by dialing, free, within the continental United States, the Whirlpool Customer Interaction Center telephone number, 1-800-253-1301. A special operator will tell you the name and number of your nearest Whirlpool-designated service company.

Maintain the quality built into your Whirlpool appliance — call a Whirlpool-designated service company.

## When moving the washer/dryer...

- Disconnect the power supply cord, then tape securely to the washer/dryer.
- Tape the drum to the front panel. Tape the lint screen in place. Tape the dryer door closed.
- Wedge a blanket between the tub ring and cabinet top to restrict tub movement.
- Turn front leveling legs all the way in.



Part No. 3397616 Rev. B

© 2000 Whirlpool Corporation

® Registered Trademark of Whirlpool, U.S.A.

Prepared by Whirlpool Corporation,  
Benton Harbor, Michigan 49022

Printed in U.S.A.