

NOTICE - This service data sheet is intended for use by persons having electrical and mechanical training and a level of knowledge of these subjects generally considered acceptable in the appliance repair trade. The manufacturer cannot be responsible, nor assume any liability for injury or damage of any kind arising from the use of this data sheet.

SAFE SERVICING PRACTICES

To avoid the possibility of personal injury and/or property damage, it is important that safe servicing practices be observed. The following are examples, but without limitation, of such practices.

1. Before servicing or moving an appliance remove power cord from electrical outlet, trip circuit breaker to OFF, or remove fuse.
2. Never interfere with the proper installation of any safety device.
3. **GROUNDING:** The standard color coding for safety ground wires is *GREEN* or *GREEN WITH*

YELLOW STRIPES. Ground leads are not to be used as current carrying conductors. **It is extremely important that the service technician reestablish all safety grounds prior to completion of service. Failure to do so will create a potential safety hazard.**

4. Prior to returning the product to service, ensure that:
 - All electric connections are correct and secure.
 - All electrical leads are properly dressed and secured away from sharp edges, high-temperature components, and moving parts.
 - All uninsulated electrical terminals, connectors, heaters, etc. are adequately spaced away from all metal parts and panels.
 - All safety grounds (both internal and external) are correctly and securely reassembled.

Oven Calibration/ Temperature adjustment - See Use & Care Guide. Note: Changing calibration affects normal Bake mode. The adjustments made will not change the Self-Cleaning cycle temperature.

Resistance Temperature Detector

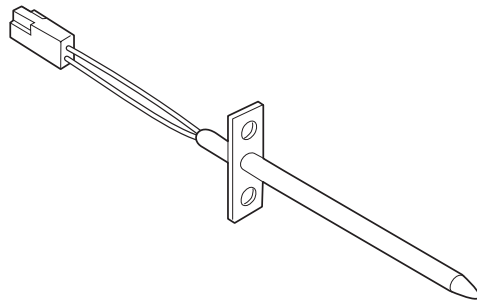

RTD SCALE	
Temperature (°F)	Resistance (ohms)
32 ± 1.9	1000 ± 4.0
75 ± 2.5	1091 ± 5.3
250 ± 4.4	1453 ± 8.9
350 ± 5.4	1654 ± 10.8
450 ± 6.9	1852 ± 13.5
550 ± 8.2	2047 ± 15.8
650 ± 9.6	2237 ± 18.5
900 ± 13.6	2697 ± 24.4

IMPORTANT
DO NOT REMOVE THIS BAG
OR DESTROY THE CONTENTS
 WIRING DIAGRAMS AND SERVICE INFORMATION ENCLOSED
REPLACE CONTENTS IN BAG

ELECTRONIC OVEN CONTROL (EOC) FAULT CODE DESCRIPTIONS

Fault Code	Symptom	Suggested Corrective Action
F10	Runaway temperature. Oven heats when no cook cycle is programmed.	1. Check RTD Sensor Probe using the RTD scale found in the tech sheet. Replace if defective. 2. If oven is overheating dsiconnect power from the range and unplug connector P1 from power supply board. Reapply power to the range. If oven continues to heat when the power is reapplied, replace the oven relay board. 3. Replace the EOC. NOTE: Severe overheating may require the entire oven to be replaced should damage be extensive.
F11	Shorted keypad.	1. Reset power supply to range to see if failure code will clear. 2 Test ribbon harness and connectors between the TST panel and EOC. Replace if defective. 3. Replace the TST panel. 4. Replace the EOC.
F13	Internal software error in EOC.	Disconnect power, wait 30 seconds and reapply power. If fault returns upon power-up, replace EOC.
F14	TST Display tail missing or not connected.	1. Test ribbon harness and connections between TST panel and EOC. Replace if defective 2. Replace the TST panel. 3. Replace the EOC.
F15	Signal loss between oven relay board & EOC.	1. Test the harness and connections from EOC connector P16 to oven relay board J2. 2. Replace the oven relay board. 3. Replace the EOC.
F20	Communication failure between EOC & ESEC. (Electric models only)	1. Test wiring harness and connections between EOC connector P2 and ESEC 30 UIB P9. 2. Test wiring harness and connections between ESEC 30 UIB and ESEC 20 relay board. 3. Test wiring harness and connections between PS board 2 (P2) and ESEC 30 UIB connector P7 4. Test for approximately 9 volts DC output from PS board 2 at ESEC 30 UIB connector P7, pins 1 & 5. If output voltage is incorrect test incoming power supply to PS board 2 at harness connector P1 pins 1 & 4. If incoming power is correct (120 VAC) replace PS board 2. If output voltage is correct replace ESEC 30 UIB 5. Replace EOC.
F23 F25	Communication failure between VSC board and EOC.	1. Check harness and connections between VSC board and EOC. 2. Test for approximately 5 volts DC to VSC board at P6 connector pins 1 & 6. If voltage is correct replace VSC board. If voltage is incorrect replace EOC.
F30 F31	Open probe connection. Shorted Probe connection	1. (F30 or F31) Check resistance at room temperature & compare to RTD Sensor resistance chart. If resistance does not match the RTD chart replace RTD Sensor Probe. Check Sensor wiring harness between EOC & Sensor Probe connector. 2. (F30 or F31) Check resistance at room temperature, if less than 500 ohms, replace RTD Sensor Probe. Check for shorted Sensor Probe harness between EOC & Probe connector.
F90	Door lock motor latch failure	<p>If latch motor does not run when clean cycle is selected:</p> <ol style="list-style-type: none"> 1. Check to see if latch motor coil is open. If open, replace latch motor assembly. 2. Test for 120 volts to the terminals of the latch motor. If voltage is correct and motor does not run replace latch motor assembly. If voltage is not correct replace EOC. <p>If latch motor runs when clean cycle is selected:</p> <ol style="list-style-type: none"> 1. Check the wiring harness between EOC & latch motor switch. Repair or replace harness as needed. 2. Test operation of the switch contacts. Replace latch motor assembly if defective. 3. Check for binding of the latch cam, latch motor rod & latch motor cam. 4. If all situations above do not solve problem, replace EOC.

GENERAL TROUBLESHOOTING DIAGRAM

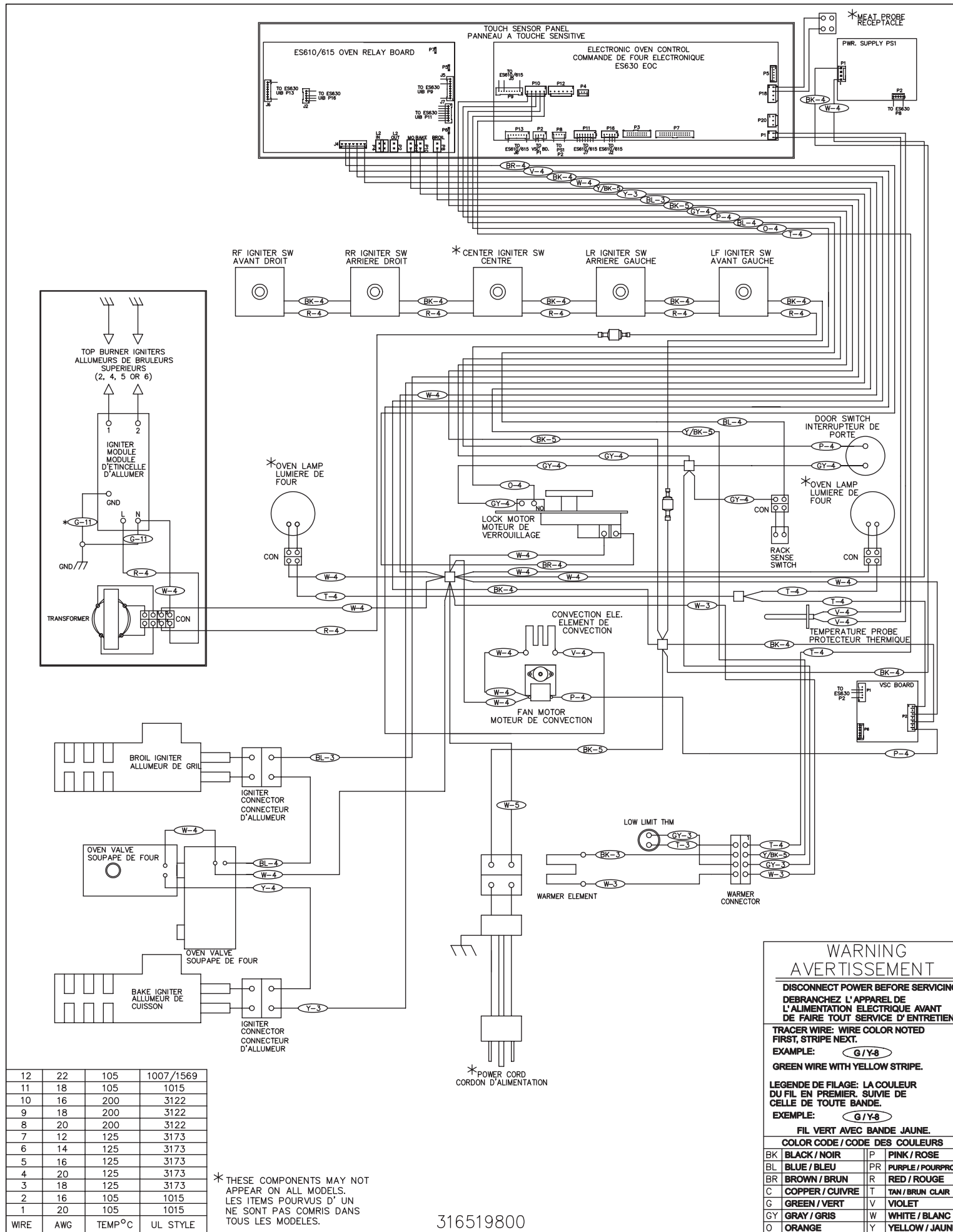

GENERAL TROUBLESHOOTING SCHEMATIC

