

27" (69 CM) ELECTRIC WASHER/DRYER INSTALLATION INSTRUCTIONS

Table of Contents

INSTALLATION INSTRUCTIONS.....	2
Tools and Parts	2
Alternate Parts	2
Location Requirements	3
Drain System	4
Electrical Requirements	4
Electrical Connection	6
Venting Requirements	11
Remove Shipping Strap	11
Install Leveling Legs	12
Connect the Drain Hose	12
Connect the Inlet Hoses.....	13
Secure the Drain Hose	13
Plan Vent System	14
Install Vent System.....	15
Level Washer/Dryer	15
Connect Vent.....	16
Complete Installation.....	16

WASHER/DRYER SAFETY

Your safety and the safety of others are very important.

We have provided many important safety messages in this manual and on your appliance. Always read and obey all safety messages.



This is the safety alert symbol.

This symbol alerts you to potential hazards that can kill or hurt you and others.

All safety messages will follow the safety alert symbol and either the word "DANGER" or "WARNING."

These words mean:

⚠ DANGER

You can be killed or seriously injured if you don't immediately follow instructions.

⚠ WARNING

You can be killed or seriously injured if you don't follow instructions.

All safety messages will tell you what the potential hazard is, tell you how to reduce the chance of injury, and tell you what can happen if the instructions are not followed.

INSTALLATION INSTRUCTIONS

Tools and Parts

Gather the required tools and parts before starting installation. Read and follow the safety instructions provided with any tools listed here.

Tools needed:

- #2 Phillips and flat-blade screwdriver
- Adjustable wrench that opens to 1" (2.5 cm) or 9/16" open-end wrench (for adjusting washer/dryer feet)
- Level
- 1/4" nut driver or socket wrench
- Wood block (for leveling)
- Ruler or measuring tape
- Wire stripper (direct wire installations)
- Knife
- Vent clamps
- Caulking gun and compound (for installing new exhaust vent)
- Pliers
- Scissors
- Tin snips (for new vent installations)

Parts supplied:

Remove parts package from the washer basket. Check that all parts were included.

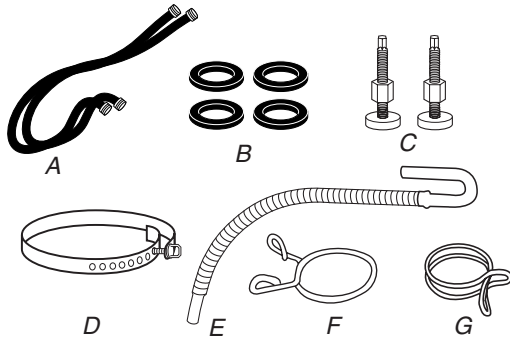

- A. Water inlet hoses (2)
- B. Inlet hose flat washers (4)
- C. Front leveling feet with nuts (2)
- D. Shipping strap (Not in parts bag. See "Remove Shipping Strap")
- E. Drain hose
- F. Yellow, single wire hose clamp
- G. Silver, double wire hose clamp

Parts needed:

Check local codes, electrical supply and venting, and read "Electrical Requirements" and "Venting Requirements" before purchasing parts.

Mobile home installations require metal exhaust system hardware available for purchase from the dealer from whom you purchased your washer/dryer. For further information, please reference the "Assistance or Service" section of the "Washer/Dryer User Instructions."

Alternate Parts

Your installation may require additional parts. For ordering information, please refer to the toll free phone numbers on the front page of the "Washer/Dryer User Instructions."

If You Have	You Will Need to Buy
Laundry tub or standpipe taller than 96" (2.4 m)	Sump pump system (if not already available)
1" (2.5 cm) diameter standpipe	2" (5 cm) diameter to 1" (2.5 cm) diameter standpipe adapter, Part Number 3363920
Overhead sewer	Standard 20 gal. (76 L) 34" (86.4 cm) tall drain tub or utility sink and sump pump (available from local plumbing suppliers)
Floor drain	Siphon break, Part Number 285320, additional drain hose, Part Number 285702 and connector kit, Part Number 285442
Drain hose too short	Drain hose, Part Number 285664 and connector kit, Part Number 285442
Lint clogged drain	Drain protector, Part Number 367031
Water faucets beyond reach of fill hoses	2 longer water fill hoses: 6 ft (1.8 m) Part Number 76314, 10 ft (3.0 m) Part Number 350008

Location Requirements

⚠ WARNING



Explosion Hazard

Keep flammable materials and vapors, such as gasoline, away from dryer.

Failure to do so can result in death, explosion, or fire.

You will need

- A location that allows for proper exhaust installation. See "Venting Requirements."
- A separate 30-amp circuit.
- A grounded electrical outlet located within 2 ft (61 cm) of either side of the washer/dryer. See "Electrical Requirements."
- A sturdy floor to support the washer/dryer weight (washer/dryer, water and load) of 500 lbs (226.8 kg).
- A level floor with a maximum slope of 1" (2.5 cm) under entire washer/dryer. Clothes may not tumble properly and automatic sensor cycles may not operate correctly if washer/dryer is not level. Installing on carpet is not recommended.
- A water heater set to deliver 120°F (49°C) water to the washer.
- Hot and cold water faucets located within 4 ft (1.2 m) of the hot and cold water fill valves, and water pressure of 5-100 psi (34.5-689.6 kPa).

The washer/dryer must not be installed or stored in an area where it will be exposed to water and/or weather.

Do not operate your washer in temperatures at or below 32°F (0°C). Some water can remain in the washer and can cause damage in low temperatures. See "Washer/Dryer Care" in the "Washer/Dryer User Instructions" for winterizing information.

Do not operate your dryer at temperatures below 45°F (7°C). At lower temperatures, the dryer might not shut off at the end of an automatic cycle. This can result in longer drying times.

Check code requirements. Some codes limit, or do not permit, installation of the washer/dryer in garages, closets, mobile homes, or sleeping quarters. Contact your local building inspector.

Installation Clearances

The location must be large enough to allow the dryer door to open fully.

Washer/Dryer Dimensions

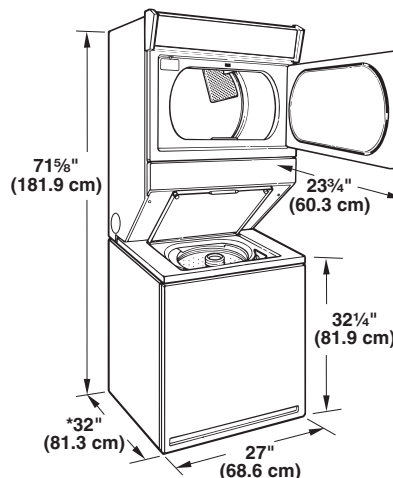

*Most installations require a minimum 5½" (14 cm) clearance behind the dryer for the exhaust vent with elbow. See "Venting Requirements."

Minimum installation spacing for recessed area or closet installation

The following dimensions shown are for the minimum spacings allowed.

- Additional spacing should be considered for ease of installation and servicing.
- Additional clearances might be required for wall, door and floor moldings.
- Additional spacing of 1" (2.5 cm) on all sides of the washer/dryer is recommended to reduce noise transfer.
- For closet installation, with a door, minimum ventilation openings in the top and bottom of the door are required. Louvered doors with equivalent ventilation openings are acceptable.
- Rear clearance may be 0" when house exhaust system is lined up directly with dryer exhaust.

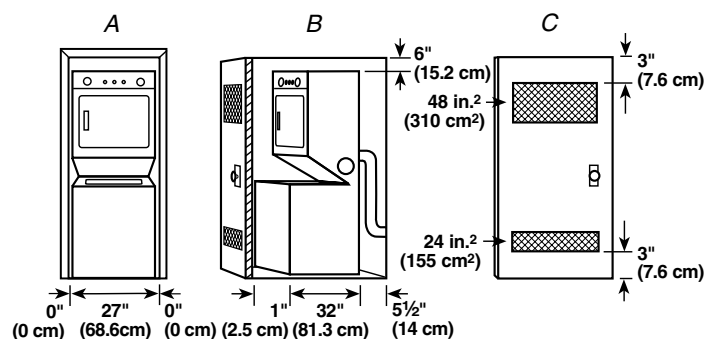

A. Recessed area
B. Side view - closet or confined area
C. Closet door with vents

Mobile Home - Additional Installation Requirements

This washer/dryer is suitable for mobile home installations. The installation must conform to the Manufactured Home Construction and Safety Standard, Title 24 CFR, Part 3280 (formerly the Federal Standard for Mobile Home Construction and Safety, Title 24, HUD Part 280).

Mobile home installations require:

- Metal exhaust system hardware which is available for purchase from your dealer.
- Special provisions must be made in mobile homes to introduce outside air into the dryer. The opening (such as a nearby window) should be at least twice as large as the dryer exhaust opening.

Drain System

The washer/dryer can be installed using the standpipe drain system (floor or wall), the laundry tub drain system, or the floor drain system. Select the drain hose installation method you need. See "Alternate Parts."

Standpipe drain system - wall or floor (views A & B)

The standpipe drain requires a minimum diameter standpipe of 2" (5 cm). The minimum carry-away capacity can be no less than 17 gal. (64 L) per minute. A 2" (5 cm) diameter to 1" (2.5 cm) diameter standpipe adapter kit is available. See "Alternate Parts."

The top of the standpipe must be at least 39" (99 cm) high and no higher than 96" (2.4 m) from the bottom of the washer.

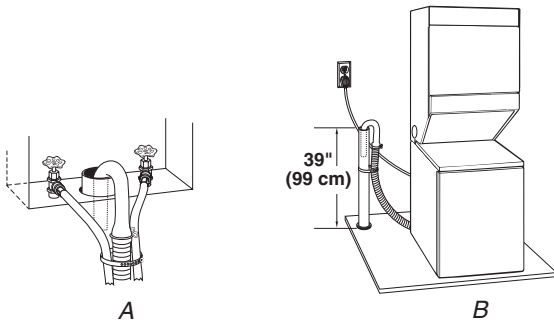

Laundry tub drain system (view C)

The laundry tub needs a minimum 20 gal. (76 L) capacity. The top of the laundry tub must be at least 34" (86.4 cm) above the floor and no higher than 96" (2.4 m) from the bottom of the washer.

Floor drain system (view D)

The floor drain system requires a siphon break that may be purchased separately. See "Alternate Parts."

The siphon break must be a minimum of 28" (71 cm) from the bottom of the washer. Additional hoses might be needed.

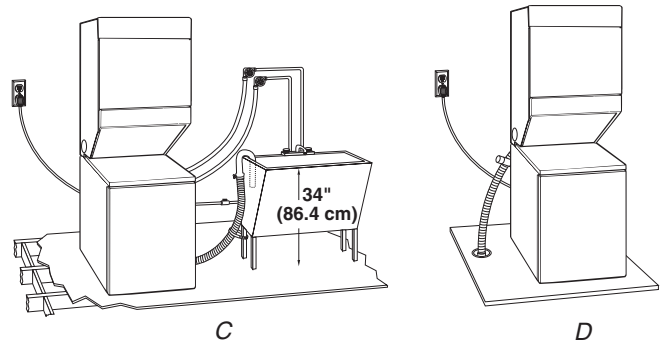

Electrical Requirements

It is your responsibility

- To contact a qualified electrical installer.
- To be sure that the electrical connection is adequate and in conformance with the National Electrical Code, ANSI/NFPA 70-latest edition and all local codes and ordinances.
A copy of the above code standards can be obtained from: National Fire Protection Association, One Batterymarch Park, Quincy, MA 02269.
- To supply the required 3 or 4 wire, single phase, 120/240-volt, 60-Hz., AC-only electrical supply (or 3 or 4 wire, 120/208-volt electrical supply, if specified on the serial/rating plate) on a separate 30-amp circuit, fused on both sides of the line. A time-delay fuse or circuit breaker is recommended. Connect to an individual branch circuit. Do not have a fuse in the neutral or grounding circuit.
- Do not use an extension cord.

- If codes permit and a separate ground wire is used, it is recommended that a qualified electrician determine that the ground path is adequate.

Electrical Connection

To properly install your washer/dryer, you must determine the type of electrical connection you will be using and follow the instructions provided for it here.

- This dryer is manufactured ready to install with a 3-wire electrical supply connection. The green cabinet-grounding conductor is permanently connected to the neutral conductor (white wire) within the dryer. If the dryer is installed with a 4-wire electrical supply connection, the green cabinet-grounding conductor must be removed from the external ground connector (green screw), and secured under the neutral terminal (center or white wire) of the terminal block. When the green cabinet-grounding conductor is secured under the neutral terminal (center or white wire) of the terminal block, the dryer cabinet is isolated from the neutral conductor.

- If local codes do not permit the connection of a cabinet ground connector to the neutral wire, see “Optional 3-wire connection” section.
- Use a 4-wire conductor cord when the dryer is installed in a mobile home or an area where local codes do not permit grounding through the neutral.

If using a power supply cord:

Use a UL listed power supply cord kit marked for use with clothes dryers. The kit should contain:

- A UL listed 30-amp power supply cord, rated 120/240 volt minimum. The cord should be type SRD or SRDT and be at least 4 ft (1.22 m) long. The wires that connect to the dryer must end in ring terminals or spade terminals with upturned ends.
- A UL listed strain relief.

If your outlet looks like this:



4-wire receptacle (14-30R)

Then choose a 4-wire power supply cord with ring or spade terminals and UL listed strain relief. The 4-wire power supply cord, at least 4 ft (1.22 m) long, must have 4, 10-gauge copper wires and match a 4-wire receptacle of NEMA Type 14-30R. The ground wire (ground conductor) may be either green or bare. The neutral conductor must be identified by a white cover.

If your outlet looks like this:



3-wire receptacle (10-30R)

Then choose a 3-wire power supply cord with ring or spade terminals and UL listed strain relief. The 3-wire power supply cord, at least 4 ft (1.22 m) long, must have 3, 10-gauge copper wires and match a 3-wire receptacle of NEMA Type 10-30R.

If connecting by direct wire:

Power supply cable must match power supply (4-wire or 3-wire) and be:

- Flexible armored cable or nonmetallic sheathed copper cable (with ground wire), protected with flexible metallic conduit. All current-carrying wires must be insulated.
- 10-gauge solid copper wire (do not use aluminum).
- At least 5 ft (1.52 m) long.

GROUNDING INSTRUCTIONS

■ For a grounded, cord-connected washer/dryer: This washer/dryer must be grounded. In the event of malfunction or breakdown, grounding will reduce the risk of electric shock by providing a path of least resistance for electric current. This washer/dryer uses a cord having an equipment-grounding conductor and a grounding plug. The plug must be plugged into an appropriate outlet that is properly installed and grounded in accordance with all local codes and ordinances.

■ For a permanently connected washer/dryer: This washer/dryer must be connected to a grounded metal, permanent wiring system, or an equipment-grounding conductor must be run with the circuit conductors and connected to the equipment-grounding terminal or lead on the washer/dryer.

WARNING: Improper connection of the equipment-grounding conductor can result in a risk of electric shock. Check with a qualified electrician or service representative or personnel if you are in doubt as to whether the washer/dryer is properly grounded. Do not modify the plug on the power supply cord: if it will not fit the outlet, have a proper outlet installed by a qualified electrician.

SAVE THESE INSTRUCTIONS

Electrical Connection

Initial Installation - for Power Supply Cord or Direct Wire Installations

Power Supply Cord

! WARNING



Fire Hazard

Use a new UL listed 30 amp power supply cord.

Use a UL listed strain relief.

Disconnect power before making electrical connections.

Connect neutral wire (white or center wire) to center terminal (silver).

Ground wire (green or bare wire) must be connected to green ground connector.

Connect remaining 2 supply wires to remaining 2 terminals (gold).

Securely tighten all electrical connections.

Failure to do so can result in death, fire, or electrical shock.

Direct Wire

! WARNING



Fire Hazard

Use 10 gauge solid copper wire.

Use a UL listed strain relief.

Disconnect power before making electrical connections.

Connect neutral wire (white or center wire) to center terminal (silver).

Ground wire (green or bare wire) must be connected to green ground connector.

Connect remaining 2 supply wires to remaining 2 terminals (gold).

Securely tighten all electrical connections.

Failure to do so can result in death, fire, or electrical shock.

1. Disconnect power.
2. Remove the hold-down screw and terminal block cover.

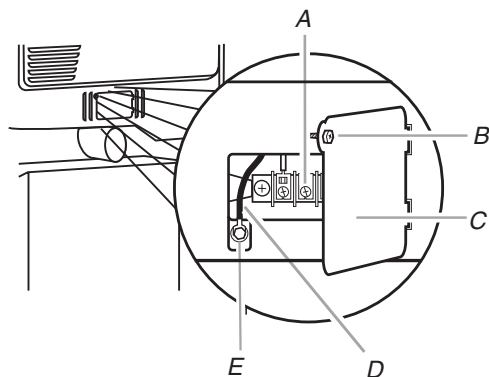

- A. Center, silver-colored terminal block screw
B. Hold-down screw
C. Terminal block cover
D. Neutral grounding wire (green with yellow stripes)
E. External ground conductor screw

3. Install strain relief.

Style 1: Power supply cord strain relief

- Remove the screws from a 3/4" (1.9 cm) UL listed strain relief (UL marking on strain relief). Put the tabs of the two clamp sections into the hole below the terminal block opening so that one tab is pointing up and the other is pointing down, and hold in place. Tighten strain relief screws just enough to hold the two clamp sections together.

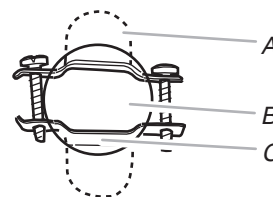

- A. Strain relief tab
B. Hole below terminal block opening
C. Clamp section

- Put power supply cord through the strain relief. Be sure that the wire insulation on the power supply cord is inside the strain relief. The strain relief should have a tight fit with the dryer cabinet and be in a horizontal position.

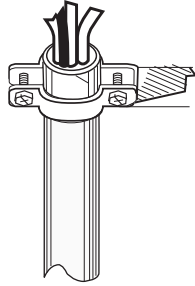

Style 2: Direct wire strain relief

- Unscrew the removable conduit connector and any screws from a 3/4" (1.9 cm) UL listed strain relief (UL marking on strain relief). Put the threaded section of the strain relief through the hole below the terminal block opening. Reaching inside the terminal block opening, screw the removable conduit connector onto the strain relief threads.

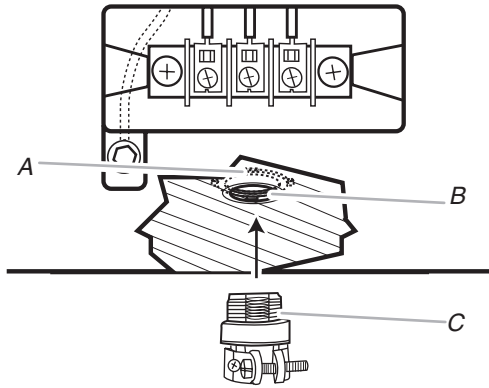

A. Removable conduit connector
B. Hole below terminal block opening
C. Strain relief threads

- Put direct wire cable through the strain relief. The strain relief should have a tight fit with the dryer cabinet and be in a horizontal position. Tighten strain relief screw against the direct wire cable.

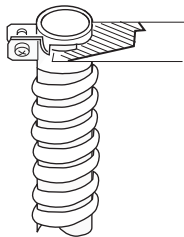



- Now complete installation following instructions for your type of electrical connection:

4-wire (recommended)

3-wire (if 4-wire is not available)

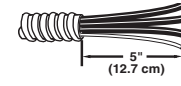
Electrical Connection Options

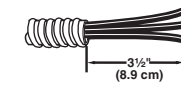
If your home has:	And you will be connecting to:	Go to Section
4-wire receptacle (NEMA Type 14-30R) 	A UL listed, 120/240 volt minimum, 30-amp, dryer power supply cord*	4-wire connection: Power supply cord
4-wire direct 	A fused disconnect or circuit breaker box*	4-wire connection: Direct Wire
3-wire receptacle (NEMA type 10-30R) 	A UL listed, 120/240 volt minimum, 30-amp, dryer power supply cord*	3-wire connection: Power supply cord
3-wire direct 	A fused disconnect or circuit breaker box*	3-wire connection: Direct Wire

*If local codes do not permit the connection of a frame-grounding conductor to the neutral wire, go to "Optional 3-wire connection" section.

4-wire connection: Power supply cord

IMPORTANT: A 4-wire connection is required for all mobile homes and where local codes do not permit the use of 3-wire connections.

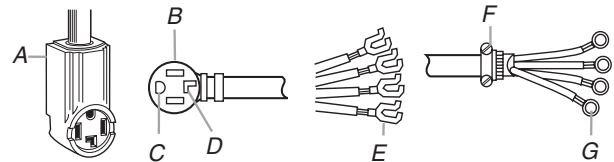

A. 4-wire receptacle (NEMA type 14-30R)
B. 4-prong plug
C. Ground prong
D. Neutral prong
E. Spade terminals with upturned ends
F. 3/4" (1.9 cm) UL listed strain relief
G. Ring terminals

- Remove center terminal block screw.

- Remove neutral grounding wire (green with yellow stripes) from external ground conductor screw. Connect neutral grounding wire and the neutral wire (white or center wire) of power supply cord under center, silver-colored terminal block screw. Tighten screw.

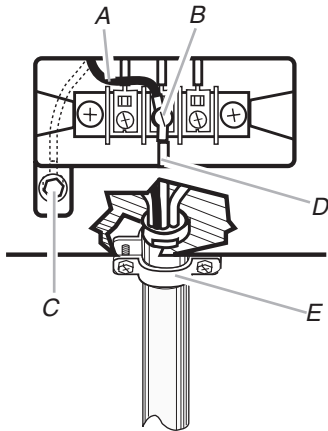

- A. Neutral grounding wire (green with yellow stripes)
- B. Center silver-colored terminal block screw
- C. External ground conductor screw
- D. Neutral wire (white or center)
- E. $\frac{3}{4}$ " (1.9 cm) UL listed strain relief

- Connect ground wire (green or bare) of power supply cord to external ground conductor screw. Tighten screw.

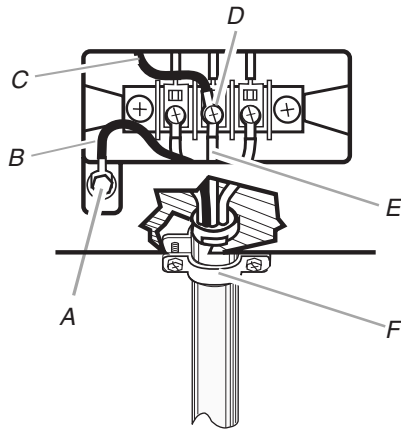

- A. External ground conductor screw
- B. Ground wire (green or bare) of power supply cord
- C. Neutral grounding wire (green with yellow stripes)
- D. Center silver-colored terminal block screw
- E. Neutral wire (white or center)
- F. $\frac{3}{4}$ " (1.9 cm) UL listed strain relief

- Connect the other wires to outer terminal block screws. Tighten screws.
- Tighten strain relief screws.
- Insert tab of terminal block cover into slot of dryer rear panel. Secure cover with hold-down screw.
- Go to "Venting Requirements."

4-wire connection: Direct Wire

IMPORTANT: A 4-wire connection is required for mobile homes and where local codes do not permit the use of 3-wire connections.

Direct wire cable must have 5 ft (1.52 m) of extra length so washer/dryer can be moved if needed.

Strip 5" (12.7 cm) of outer covering from end of cable, leaving bare ground wire at 5" (12.7 cm). Cut $1\frac{1}{2}$ " (3.8 cm) from 3 remaining wires. Strip insulation back 1" (2.5 cm). Shape ends of wires into a hook shape.

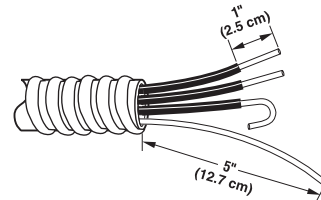

When connecting to the terminal block, place the hooked end of the wire under the screw of the terminal block (hook facing right), squeeze hooked end together and tighten screw, as shown.



- Remove center terminal block screw.
- Remove neutral grounding wire (green with yellow stripes) from external ground conductor screw. Connect neutral grounding wire and place the hooked end (hook facing right) of the neutral wire (white or center wire) of direct wire cable under the center screw of the terminal block. Squeeze hooked ends together. Tighten screw.

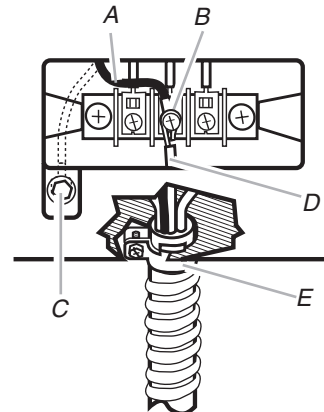

- A. Neutral grounding wire (green with yellow stripes)
- B. Center silver-colored terminal block screw
- C. External ground conductor screw
- D. Neutral wire (white or center wire)
- E. $\frac{3}{4}$ " (1.9 cm) UL listed strain relief

3. Connect ground wire (green or bare) of direct wire cable to external ground conductor screw. Tighten screw.

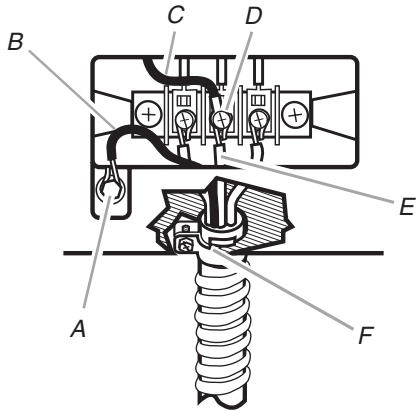

- A. External ground conductor screw
- B. Ground wire (green or bare) of power supply cord
- C. Neutral grounding wire (green with yellow stripes)
- D. Center silver-colored terminal block screw
- E. Neutral wire (white or center)
- F. $\frac{3}{4}$ " (1.9 cm) UL listed strain relief

4. Place the hooked ends of the other power supply cable wires under the outer terminal block screws (hooks facing right). Squeeze hooked ends together. Tighten screws.

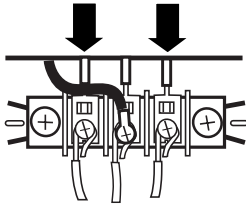

5. Tighten strain relief screw.
6. Insert tab of terminal block cover into slot of dryer rear panel. Secure cover with hold-down screw.
7. Go to "Venting Requirements."

3-wire connection: Power supply cord

Use where local codes permit connecting cabinet-ground conductor to neutral wire.

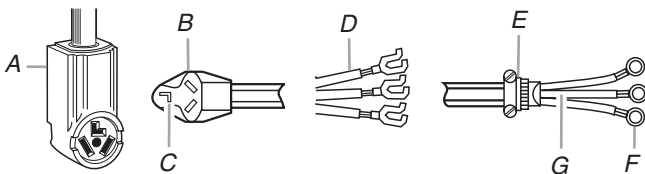

- A. 3-wire receptacle (NEMA type 10-30R)
- B. 3-wire plug
- C. Neutral prong
- D. Spade terminals with up turned ends
- E. $\frac{3}{4}$ " (1.9 cm) UL listed strain relief
- F. Ring terminals
- G. Neutral (white or center wire)

1. Loosen or remove center terminal block screw.

2. Connect neutral wire (white or center wire) of power supply cord to the center, silver-colored terminal screw of the terminal block. Tighten screw.

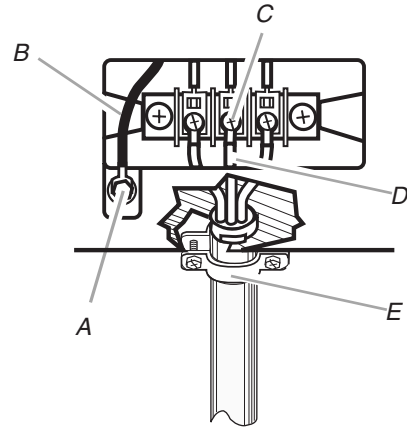

- A. External ground conductor screw
- B. Neutral grounding wire (green with yellow stripes)
- C. Center silver-colored terminal block screw
- D. Neutral wire (white or center wire)
- E. $\frac{3}{4}$ " (1.9 cm) UL listed strain relief

3. Connect the other wires to outer terminal block screws. Tighten screws.
4. Tighten strain relief screws.
5. Insert tab of terminal block cover into slot of dryer rear panel. Secure cover with hold-down screw.
6. Go to "Venting Requirements."

3-wire connection: Direct Wire

Use where local codes permit connecting cabinet-ground conductor to neutral wire.

Direct wire cable must have 5 ft (1.52 m) of extra length so washer/dryer can be moved if needed.

Strip $\frac{3}{2}$ " (8.9 cm) of outer covering from end of cable. Strip insulation back 1" (2.5 cm) If using 3-wire cable with ground wire, cut bare wire even with outer covering. Shape ends of wires into a hook shape.

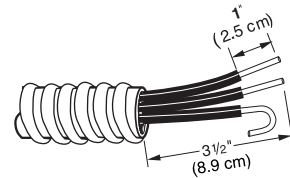

When connecting to the terminal block, place the hooked end of the wire under the screw of the terminal block (hook facing right), squeeze hooked end together and tighten screw, as shown.



1. Loosen or remove center terminal block screw.

- Place the hooked end of the neutral wire (white or center wire) of direct wire cable under the center screw of terminal block (hook facing right). Squeeze hooked end together. Tighten screw.

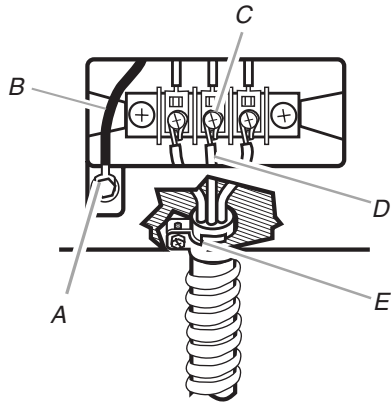

- A. External ground conductor screw
- B. Neutral grounding wire (green with yellow stripes)
- C. Center silver-colored terminal block screw
- D. Neutral wire (white or center wire)
- E. $\frac{3}{4}$ " (1.9 cm) UL listed strain relief

- Place the hooked ends of the other power supply cable wires under the outer terminal block screws (hooks facing right). Squeeze hooked ends together. Tighten screws.

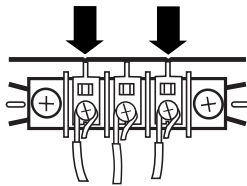

- Tighten strain relief screw.
- Insert tab of terminal block cover into slot of dryer rear panel. Secure cover with hold-down screw.
- Go to "Venting Requirements."

Optional 3-wire connection

Use for direct wire or power supply cord where local codes do not permit connecting cabinet-ground conductor to neutral wire.

- Remove center terminal block screw.
- Remove neutral grounding wire (green with yellow stripes) from external ground conductor screw. Connect neutral grounding wire and the neutral wire (white or center wire) of power supply cord/cable under center, silver-colored terminal block screw. Tighten screw.

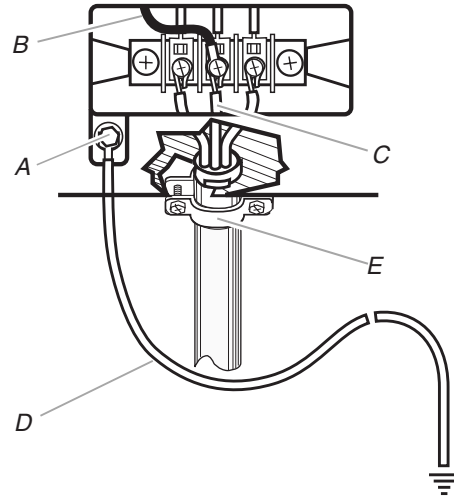

- A. External ground conductor screw
- B. Neutral grounding wire (green with yellow stripes)
- C. Neutral wire (white or center wire)
- D. Grounding path determined by a qualified electrician
- E. $\frac{3}{4}$ " (1.9 cm) UL listed strain relief

- Connect the other wires to outer terminal block screws. Tighten screws.

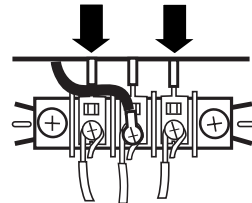

- Tighten strain relief screws.
- Insert tab of terminal block cover into slot of dryer rear panel. Secure cover with hold-down screw.
- Connect a separate copper ground wire from the external ground conductor screw to an adequate ground.

Venting Requirements

⚠️ WARNING



Fire Hazard

- Use a heavy metal vent.
- Do not use a plastic vent.
- Do not use a metal foil vent.
- Failure to follow these instructions can result in death or fire.

WARNING: To reduce the risk of fire, this washer/dryer MUST BE EXHAUSTED OUTDOORS.

4" (10.2 cm) heavy metal exhaust vent and clamps must be used. DURASAFE™ venting products are recommended.

DURASAFE™ vent products can be purchased from your dealer or by calling Whirlpool Parts and Accessories. For more information, see the "Assistance or Service" section of the "Washer/Dryer User Instructions."

- The dryer exhaust must not be connected into any gas vent, chimney, wall, ceiling, or a concealed space of a building.
- Do not use an exhaust hood with a magnetic latch.
- Do not install flexible metal vent in enclosed walls, ceilings or floors.
- Use clamps to seal all joints. Exhaust vent must not be connected or secured with screws or other fastening devices which extend into the interior of the duct. Do not use duct tape.

IMPORTANT: Observe all governing codes and ordinances.

Improper venting can cause moisture and lint to collect indoors, which may result in:

- Moisture damage to woodwork, furniture, paint, wallpaper, carpets, etc.
- Housecleaning problems and health problems.

Use a heavy metal vent. Do not use plastic or metal foil vent. Rigid metal vent is recommended to prevent crushing and kinking. Flexible metal vent must be fully extended and supported when the washer/dryer is in its final position. Remove excess flexible metal vent to avoid sagging and kinking that may result in reduced airflow and poor performance.

An exhaust hood should cap the vent to prevent rodents and insects from entering the home.

Exhaust hood must be at least 12" (30.5 cm) from the ground or any object that may be in the path of the exhaust (such as flowers, rocks or bushes, etc.).

If using an existing vent system, clean lint from the entire length of the system and make sure exhaust hood is not plugged with lint. Replace any plastic or metal foil vent with rigid metal or flexible metal vent.

Remove Shipping Strap

⚠️ WARNING

Excessive Weight Hazard

Use two or more people to move and install washer/dryer.

Failure to do so can result in back or other injury.

To prevent floor damage, set washer/dryer onto cardboard before moving across floor. Move washer/dryer close to its final location.

1. Do not cut yellow strap. Pull yellow strap firmly, until completely removed from washer/dryer. There should be 2 cotter pins on the end of the shipping strap. Remove the hang tag and pin from the vent pipe.

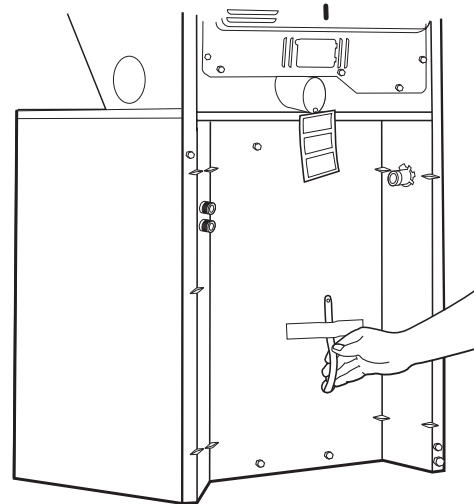

2. Tilt the washer/dryer forward. Move each of the 2 rear legs in an up-down motion to check the self-adjusting leveling legs for free movement. This is required for proper leveling. Gently lower the washer/dryer to the floor.
3. Cut the shipping strap about 16" (40.6 cm) from the plug end. Look for the words "CUT HERE." Discard end with cotter pins. You will use the remaining piece of shipping strap to secure the drain hose.

Install Leveling Legs

Install the front leveling feet

1. Prop up the front of the washer/dryer about 4" (10.2 cm) with a wood block or similar object. The block needs to support the weight of the washer/dryer.
2. Screw the locknut onto each foot to within 1" (2.5 cm) of the base.

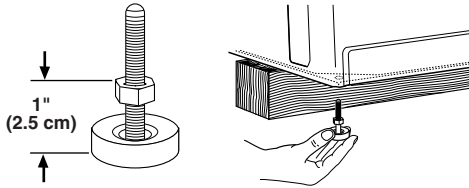

3. Screw the feet into the correct holes at the front corner of the washer/dryer until the nuts touch the washer.
NOTE: Do not tighten the nuts until the washer/dryer is level.
4. Tilt the washer/dryer back and remove the wood block. Gently lower the washer/dryer to the floor.

Connect the Drain Hose

Proper connection of the drain hose protects your floors from damage due to water leakage. To prevent the drain hose from coming off or leaking, it must be installed according to the following instructions:

IMPORTANT: To ensure proper installation, this procedure must be followed exactly.

1. Check the drain hose to see whether it is the proper length.
2. Wet the inside of the straight end of the drain hose with tap water.

IMPORTANT: Do not use any lubricant other than water.

3. Squeeze ears of the silver, double-wire clamp with pliers to open. Place clamp over the straight end of the drain hose $\frac{1}{4}$ " (6.4 mm) from the end.

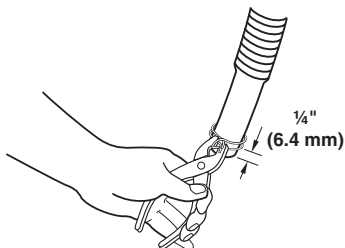

4. Open clamp. Twist hose back and forth while pushing onto drain connector on the side of the washer/dryer. Continue until hose contacts the ribbed stops on the cabinet.

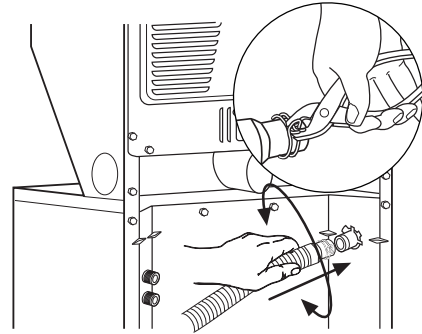

5. Place clamp over the area marked "CLAMP." Release clamp.

For laundry tub or standpipe drain systems

1. Open the yellow single-wire clamp and slide over the hooked end of the drain hose to secure the rubber and corrugated sections together.

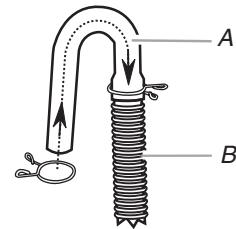

A. Hooked end
B. Drain hose

2. Put hooked end of drain hose into laundry tub or standpipe. Rotate hook to eliminate kinks.

To prevent drain water from going back into the washer:

- Do not straighten hooked end of the drain hose and force excess drain hose into standpipe. Hose should be secure but loose enough to provide a gap for air.
- Do not lay excess hose on the bottom of the laundry tub.

For use with floor drain

Remove the drain hose hook from the corrugated drain hose. You may need additional parts. See "Floor drain" under "Alternate Parts."

Connect the Inlet Hoses

1. Insert a new flat washer (supplied) into each end of the inlet hoses. Firmly seat the washers in the couplings.

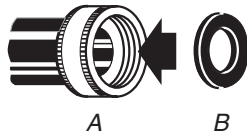

A. Coupling
B. Washer

Connect the inlet hoses to the water faucets

Make sure the washer basket is empty.

2. Attach the hose with the red coupling to the hot water faucet. Screw on coupling by hand until it is seated on the washer.
3. Attach the hose with the blue coupling to the cold water faucet. Screw on coupling by hand until it is seated on the washer.
4. Using pliers, tighten the couplings with an additional two-thirds turn.

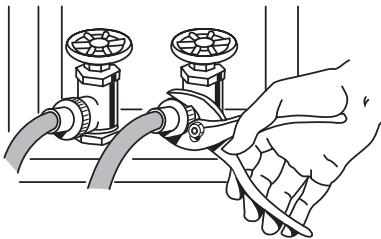

NOTE: Do not overtighten. Damage to the valves can result.

Clear the water lines

5. Run water through both faucets and inlet hoses, into a bucket or laundry tub, to get rid of particles in the water lines that might clog the inlet valve screens.

Connect the inlet hoses to the washer

6. Attach the hose with the blue coupling to the cold water (top) inlet valve. Screw on coupling by hand until it is seated on the washer. Using pliers, tighten the couplings with an additional two-thirds turn.

NOTE: Do not overtighten. Damage to the valves can result.

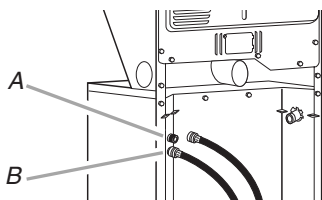

A. Cold water inlet valve (blue)
B. Hot water inlet valve (red)

7. Attach the hose with the red coupling to the hot water (bottom) inlet valve. Screw on coupling by hand until it is seated on the washer. Using pliers, tighten the couplings with an additional two-thirds turn.

NOTE: Do not overtighten. Damage to the valves can result.

If you are working in a closet or recessed area

Move the washer/dryer into its final position and remove cardboard from under washer/dryer. Remove the access panel by removing 3 Phillips-head screws and one bumper, located at the top of the access panel. Set panel, screw, and bumper aside. Complete hookup of water hoses. Replace access panel upon completion of washer/dryer installation.

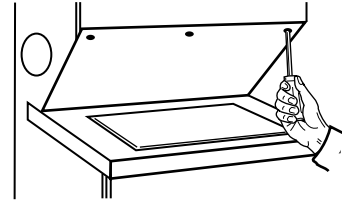

Check for leaks

8. Turn on the water faucets and check for leaks. A small amount of water might enter the washer. You will drain this later.

NOTE: Replace inlet hoses after 5 years of use to reduce the risk of hose failure. Record hose installation or replacement dates for future reference.

- If you connect only one water hose, you must cap off the remaining water inlet port.
- Periodically inspect and replace hoses if bulges, kinks, cuts, wear, or leaks are found.
- The apparatus must be connected to the water faucets using the new hoses. Do not use old hoses.

Secure the Drain Hose

1. Move the washer/dryer to its final location and remove any cardboard used to move the washer/dryer.
2. Locate the remaining piece of shipping strap. See "Remove Shipping Strap."

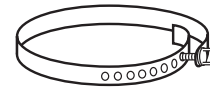

Shipping strap

3. Wrap the drain hose to the laundry tub leg or standpipe with the shipping strap (A or B below). Push fastener into the nearest hole in the shipping strap (see illustration above).

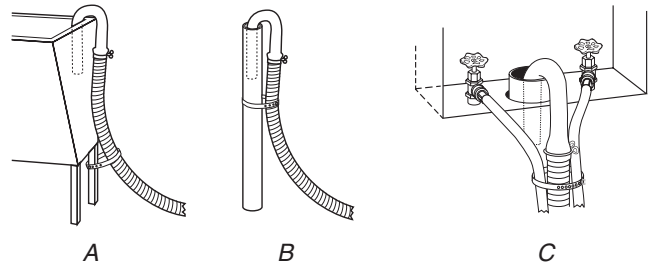

If the water faucets and the drain standpipe are recessed, put the hooked end of the drain hose in the standpipe. Tightly wrap the shipping strap around the water inlet hoses and the drain hose (C above). Push fastener into the nearest hole in the shipping strap (see illustration above).

Plan Vent System

Typical exhaust installations

Typical installations vent the dryer from rear of the washer/dryer. Other installations are possible.

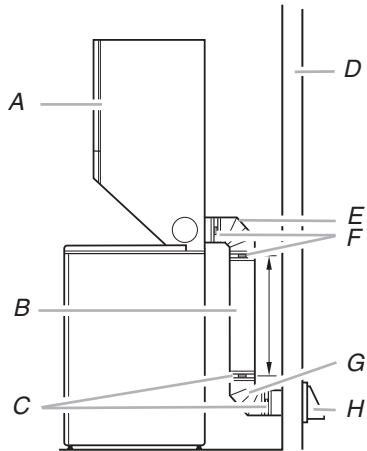

- | | |
|---------------------------------------|-----------------|
| A. Dryer | E. Elbow |
| B. Rigid metal or flexible metal vent | F. Clamps |
| C. Clamps | G. Elbow |
| D. Wall | H. Exhaust hood |

Optional exhaust installations

This washer/dryer can be converted to exhaust out the right or left side. To convert the washer/dryer, use Side Exhaust Kit Part Number 279823. If your washer/dryer was previously exhausted from the right or left side, it can be converted to rear exhaust by using standard offset connections. To cover the hole in the side, one of the following plugs can be added:

692790 (white)

3977784 (biscuit)

Follow the instructions in the kit to install. Kits are available from the dealer from whom you purchased your washer/dryer.

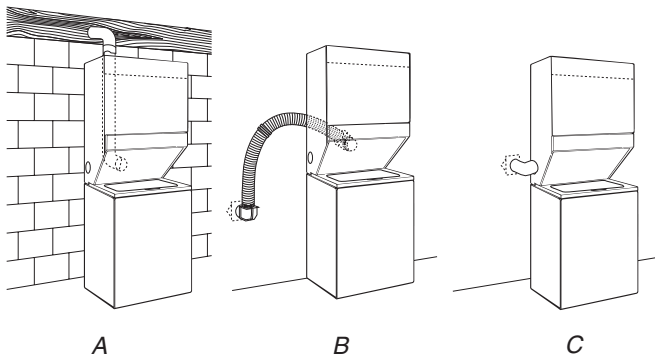

- A. Standard rear offset exhaust installation
 B. Rear exhaust for offset close clearance connection
 C. Left or right side exhaust installation

Alternate installations for close clearances

Venting systems come in many varieties. Select the type best for your installation. Three close-clearance installations are shown.

Refer to the manufacturer's instructions provided with the vent system.

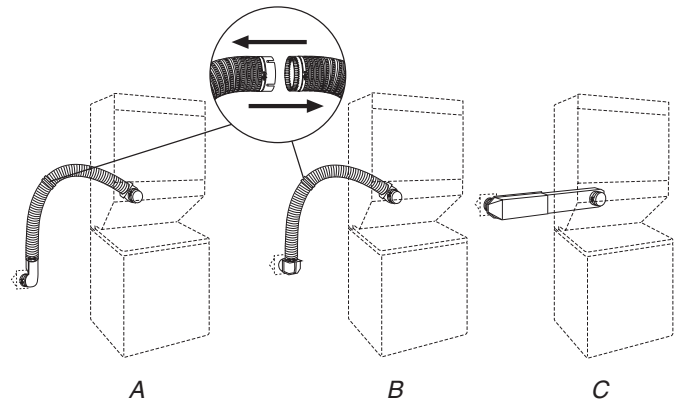

- A. Loop system with standard elbows
 B. Loop system with one offset and one standard elbow
 C. Vent system with one periscope (2" [5 cm] clearance)

NOTE: The following kits for close clearance alternate installations are available for purchase. Please reference the "Assistance or Service" section of the "Washer/Dryer User Instructions."

- Over the top Installation:
Part Number 4396028
- Periscope Installation (For use with dryer vent to wall vent mismatch):
Part Number 4396037 - 0" (0 cm) to 18" (45.72 cm) mismatch
Part Number 4396011 - 18" (45.72 cm) to 29" (73.66 cm) mismatch
Part Number 4396014 - 29" (73.66 cm) to 50" (127 cm) mismatch

Special provisions for mobile home installations

The exhaust vent must be securely fastened to a noncombustible portion of the mobile home structure and must not terminate beneath the mobile home. Terminate the exhaust vent outside.

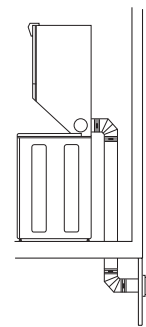

Determine vent length

1. Select the route that will provide the straightest and most direct path outdoors. Plan the installation to use the fewest number of elbows and turns. When using elbows or making turns, allow as much room as possible. Bend vent gradually to avoid kinking. Avoid 90° turns when possible.

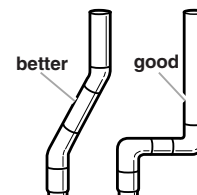

2. Determine vent length.

The maximum length of the exhaust system depends upon:

- The type of vent (rigid metal or flexible metal).
- The number of elbows used.
- Type of hood.

Recommended hood styles are shown here.

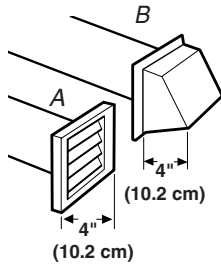

A. Louvered hood style
B. Box hood style

The angled hood style (shown following) is acceptable.

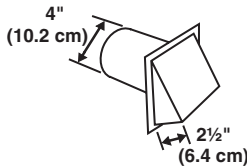

See the exhaust vent length chart that matches your hood type for the maximum vent lengths you can use.

Exhaust systems longer than specified will:

- Shorten the life of the dryer.
- Reduce performance, resulting in longer drying times and increased energy usage.

3. Determine the number of elbows you will need.

IMPORTANT: Do not use vent runs longer than those specified in Vent Length Chart.

The following chart helps you determine your maximum vent length based on the number of 90° turns or elbows you will need and the type of vent (rigid or flexible metal) and hood that you will use.

Vent Length Chart

No. of 90° turns or elbows	Type of Vent	Box or Louvered hoods	Angled hoods
0	Rigid metal	37 ft (11.3 m)	35 ft (10.7 m)
	Flexible metal	25 ft (7.6 m)	20 ft (6.1 m)
1	Rigid metal	32 ft (9.7 m)	27 ft (8.2 m)
	Flexible metal	21 ft (6.4 m)	16 ft (4.9 m)
2	Rigid metal	24 ft (7.3 m)	19 ft (5.8 m)
	Flexible metal	15 ft (4.6 m)	10 ft (3.0 m)

NOTE: Side exhaust adds a 90° turn inside the washer/dryer. To determine maximum exhaust length, add one 90° turn to the chart.

Install Vent System

1. Install exhaust hood. Use caulking compound to seal exterior wall opening around exhaust hood.
2. Connect vent to exhaust hood. Vent must fit inside exhaust hood. Secure vent to exhaust hood with 4" (10.2 cm) clamp.
3. Run vent to dryer location. Use the straightest path possible. See "Determine vent length." Avoid 90° turns. Use clamps to seal all joints. Do not use duct tape, screws or other fastening devices that extend into the interior of the vent to secure vent.

Level Washer/Dryer

Properly leveling your washer/dryer prevents excessive noise and vibration.

1. Check the levelness of the washer/dryer by placing a level on the top edge of the washer, first side to side, then front to back.

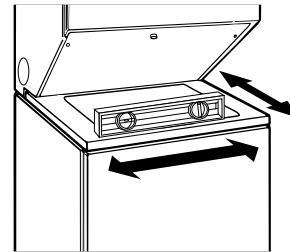

2. If the washer/dryer is not level, prop up the front with the wood block and adjust the feet up or down as necessary. Remove wood block.

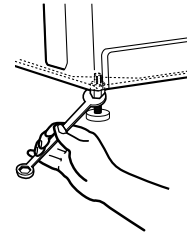

3. Tilt the washer/dryer forward until the rear of the washer/dryer is at least 4" (10.2 cm) off the floor. You may hear the self-adjusting rear feet click into place. Lower the washer/dryer to the floor. Check the levelness of the washer/dryer with a level as shown above.

If washer/dryer will not level, recheck rear leveling legs for free movement as described in the "Install Leveling Legs" section. Repeat until the washer/dryer is level.

NOTE: It may be necessary to level the washer/dryer again after it is moved into its final position.

4. After the washer/dryer is in the final location and level, use an adjustable or open-end wrench to turn the nuts on the front feet tightly against the washer cabinet.

If the nuts are not tight against the washer cabinet, the washer/dryer may vibrate.

Connect Vent

1. Using a 4" (10.2 cm) clamp, connect vent to exhaust outlet in washer/dryer. If connecting to existing vent, make sure the vent is clean. The vent must fit over the exhaust outlet and inside the exhaust hood. Make sure the vent is secured to exhaust hood with a 4" (10.2 cm) clamp.
2. Move washer/dryer into final position. Do not crush or kink vent. Make sure washer/dryer is level.

Complete Installation

1. Check to be sure all parts are now installed. If there is an extra part, go back through the steps to see which step was skipped.
2. Check to be sure you have all of your tools.
3. Dispose of/recycle all packaging materials. Keep the plastic foam for use if the washer/dryer should be transported.
4. Check the washer/dryer's final location. Be sure the vent is not crushed or kinked.
5. Check to be sure the washer/dryer is level and front leveling feet are tight. See "Level Washer/Dryer."
6. Plug into a grounded outlet. Turn on power.
7. Check to be sure the water faucets are on.
8. Check for leaks around faucets and inlet hoses.
9. Remove the blue protective film on the console and any tape remaining on the washer/dryer.
10. Read the "Washer/Dryer User Instructions."

11. Wipe the dryer drum interior thoroughly with a damp cloth to remove any dust.
12. To test the washer, measure ½ the normal recommended amount of detergent and pour it into the washer. Close the lid. Select HEAVY DUTY and pull out the Cycle Control knob. Allow the washer to complete one whole cycle.
13. To test the dryer, set the dryer on a full heat cycle (not an air cycle) for 20 minutes and start the dryer.

If the dryer will not start, check the following:

- Controls are set in a running or "On" position.
 - Start button has been firmly pushed.
 - Washer/dryer is plugged into a grounded outlet.
 - Electrical supply is connected.
 - House fuse is intact and tight, or circuit breaker has not tripped.
 - Dryer door is closed.
14. When the dryer has been running for 5 minutes, open the dryer door and feel for heat.
- ### If you do not feel heat, turn off the dryer and check the following:
- There may be 2 fuses or circuit breakers for the dryer. Check to make sure both fuses are intact and tight, or that both circuit breakers have not tripped. If there is still no heat, contact a qualified technician.

NOTE: You may notice a burning odor when dryer is first heated. This odor is common when the heating element is first used. The odor will go away.