

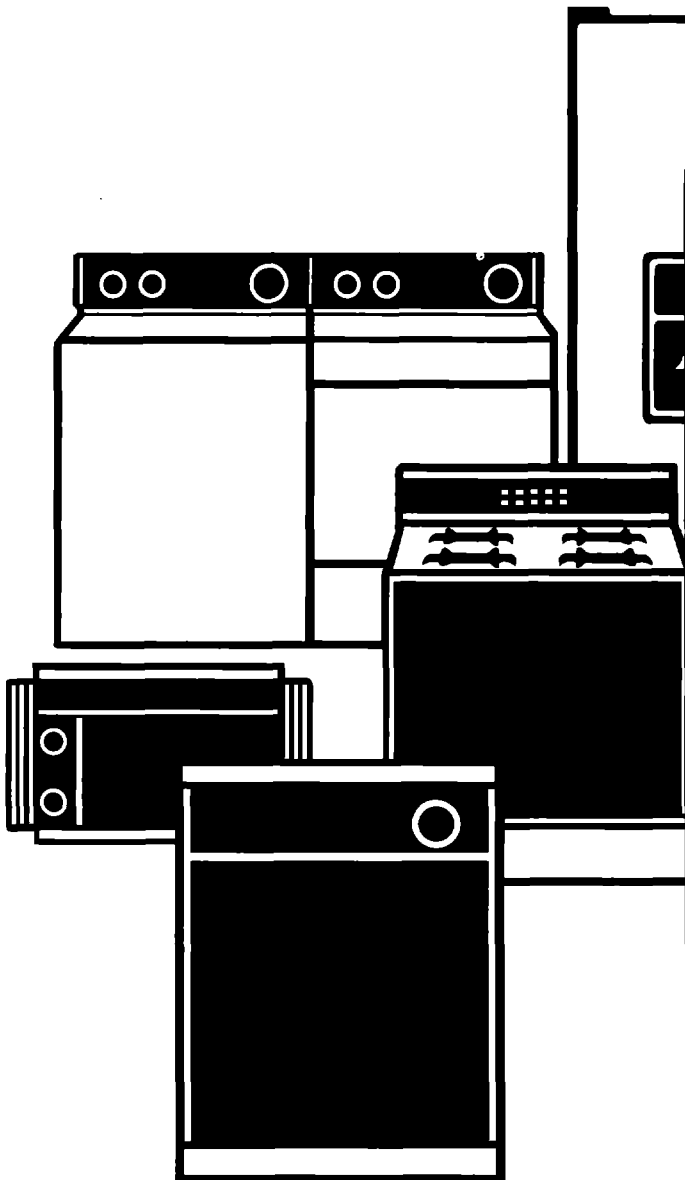

Use And Care

GUIDE



A Note To You	2
Freezer Safety	3
Proper Disposal of Your Old Freezer or Refrigerator	4
Parts and Features	5
Installing Your Freezer	6
Using Your Freezer	8
Setting the temperature control	8
Adjusting the temperature control	8
Using the key eject lock	9
Using the refrigerated shelves	9
Using the storage gate	10
Removing the base grille ..	10
Changing the light bulb	10
Caring For Your Freezer	12
Troubleshooting	14
Requesting Assistance or Service	15
Warranty	16

Call us at 1-800-253-1301
with questions and comments or
visit our website at...
www.estateappliances.com

UPRIGHT FREEZERS

8-98

A Note To You

Thank you for buying an ESTATE® appliance.

Because your life is getting busier and more complicated, ESTATE appliances are easy to use, save time, and help you manage your home better. To ensure you enjoy years of trouble-free operation, we developed this Use and Care Guide. It contains valuable information about how to operate and maintain your appliance properly and safely. Please read it carefully. Also, please complete and mail the Ownership Registration Card provided with your appliance. This card helps us notify you about any new information on your appliance.

Please record your model's information.

Whenever you call to request service on your appliance, you need to know your complete model number and serial number. You can find this information on the model and serial number label (see diagram on page 5 for location of label).

Please also record the purchase date of your appliance and your dealer's name, address, and telephone number.

Model Number _____

Serial Number _____

Purchase Date _____

Dealer Name _____

Dealer Address _____

Dealer Phone _____

Keep this book and the sales slip together in a safe place for future reference.

**Our Consumer Assistance Center number, 1-800-253-1301,
is toll-free from anywhere in the U.S.A.**

**To find detailed product information, the location of the nearest Estate dealer
or authorized servicer, to purchase an accessory item, or register your
appliance on-line, please visit our website at
www.estateappliances.com**

Freezer Safety

Your safety and the safety of others is very important.

We have provided many important safety messages in this manual and on your appliance. Always read and obey all safety messages.



This is the safety alert symbol.

This symbol alerts you to hazards that can kill or hurt you and others.

All safety messages will be preceded by the safety alert symbol and the word "DANGER" or "WARNING." These words mean:

⚠ DANGER

You will be killed or seriously injured if you don't follow instructions.

⚠ WARNING

You can be killed or seriously injured if you don't follow instructions.

All safety messages will identify the hazard, tell you how to reduce the chance of injury, and tell you what can happen if the instructions are not followed.

Important Safety Instructions

WARNING: To reduce the risk of fire, electric shock, or injury when using your freezer, follow these basic precautions:

- Plug into a grounded 3 prong outlet.
- Do not remove ground prong.
- Do not use an adapter.
- Do not use an extension cord.
- Keep key away from children.
- Disconnect power before servicing.
- Replace all panels before operating.
- Remove doors or lid from your old freezer or refrigerator.
- Use nonflammable cleaner.
- Keep flammable materials and vapors, such as gasoline, away from freezer.
- Use two or more people to move or install freezer.

– SAVE THESE INSTRUCTIONS –

Proper Disposal of Your Old Freezer or Refrigerator

⚠ WARNING

Suffocation Hazard

Remove doors or lid from your old freezer or refrigerator.

Failure to do so can result in death or brain damage.

IMPORTANT: Child entrapment and suffocation are not problems of the past. Junked or abandoned freezers or refrigerators are still dangerous...even if they will sit for "just a few days."

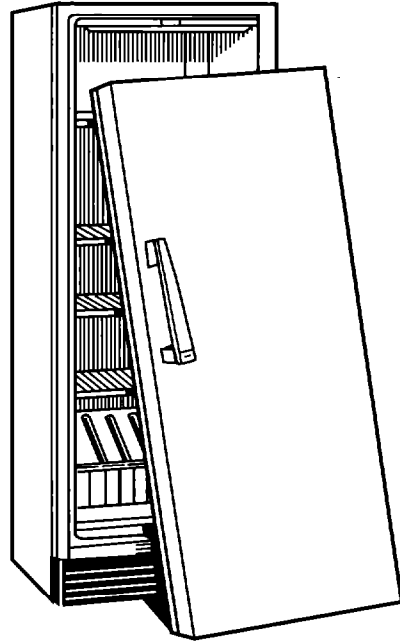

BEFORE YOU THROW AWAY YOUR OLD FREEZER OR REFRIGERATOR:

- Take off the doors or lid.
- Leave the shelves in place so that children may not easily climb inside.

Parts and Features

This captioned illustration of your freezer will help you become familiar with where all parts and features are located and what they look like.

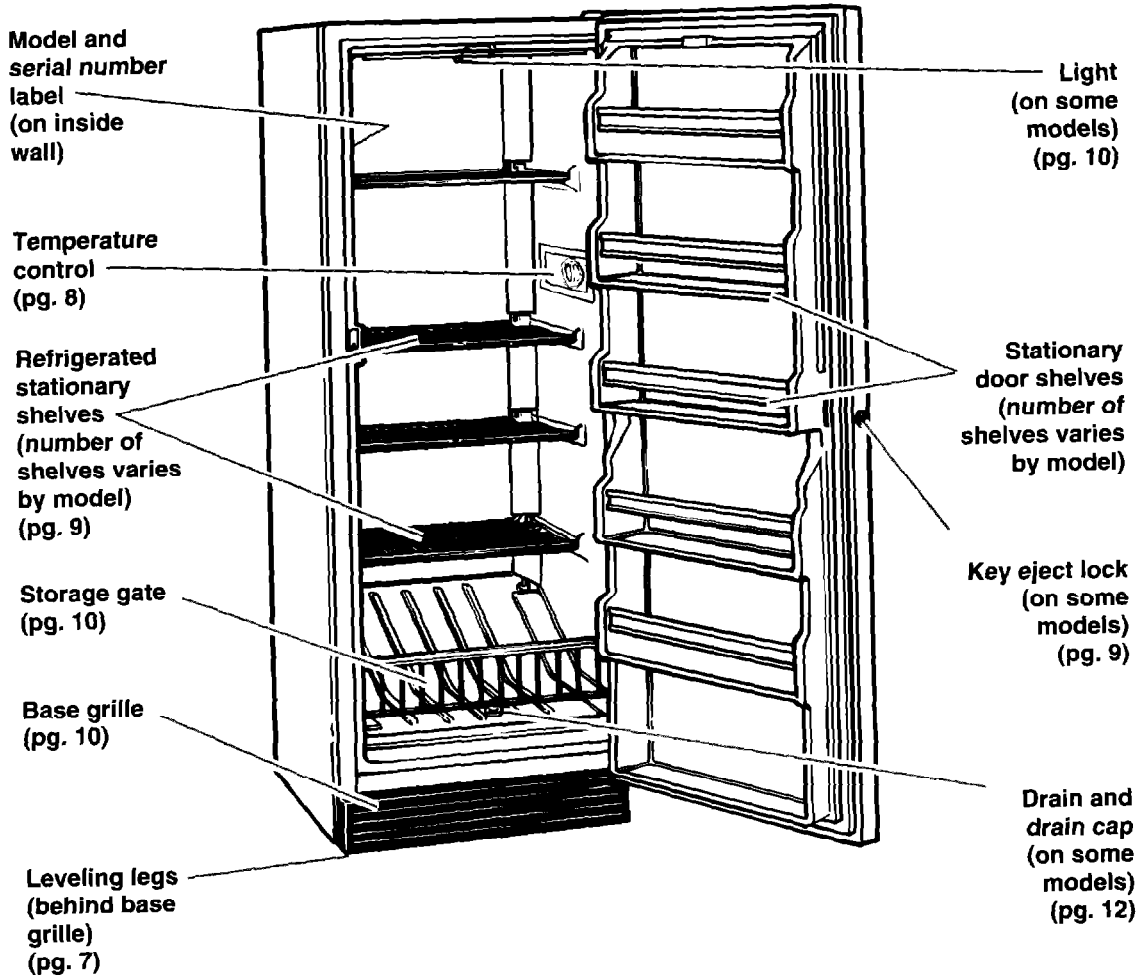

Installing Your Freezer

Proper installation of any appliance is very important. This section will tell you everything you need to know to install your freezer properly.

⚠️ WARNING

Excessive Weight Hazard

Use two or more people to move or install freezer.

Failure to do so can result in back or other injury.

Cleaning your freezer

Clean your freezer thoroughly before using it.

1. DO NOT remove the model and serial number label or the tech sheet label. If your freezer has a Consumer Buy Guide Label, remove it, any packaging materials, tape, and inside labels before using the freezer.

NOTE: To remove any remaining glue:

- Rub briskly with thumb to make a ball, then remove.

OR

- Soak area with liquid hand or dishwashing detergent before removing glue as described in Step 1.
- 2. Use a clean sponge or soft cloth and mild detergent in warm water to clean outside and inside of the freezer, door liner, and gasket.
- 3. Rinse well and wipe dry with a clean soft cloth.

Grounding Instructions

⚠️ WARNING



Electrical Shock Hazard

Plug into a grounded 3 prong outlet.

Do not remove ground prong.

Do not use an adapter.

Do not use an extension cord.

Failure to follow these instructions can result in death, fire, or electrical shock.

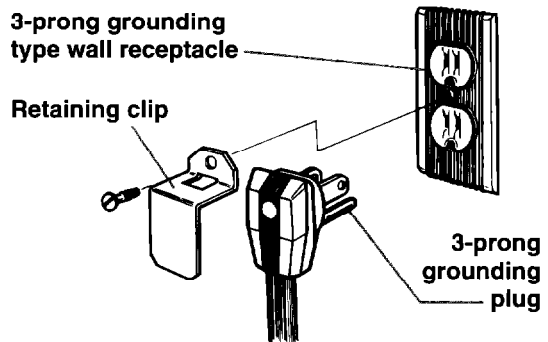

Recommended Grounding Method

A 115 Volt, 60 Hz., AC only 15 or 20 ampere fused and properly grounded electrical supply is required. It is recommended that a separate circuit serving only this appliance be provided. Use a receptacle which cannot

be turned off with a switch or pull chain. Do not use an extension cord.

Attach retaining clip, from literature package inside the freezer, over power cord plug.

Choosing the proper location

⚠ WARNING



Explosion Hazard

Keep flammable materials and vapors, such as gasoline, away from freezer. Failure to do so can result in death, explosion, or fire.

Read the following items before choosing the location for the freezer. See “Completing the Installation” section below **before** sliding freezer into place.

1. Your freezer operates most efficiently when located in an area where the temperature is normally between 32°F (0°C) and 110°F (43°C).
2. Keep flammable materials and vapors, such as gasoline, away from freezer. Do not install the freezer near an oven, radiator, or other heat source.

3. Check the strength of the floor. It should hold the weight of a freezer fully loaded with food.
4. Allow at least 3 inches (7.5 cm) of air space at top and on both sides of the freezer and 1 inch (2.5 cm) between the back of the freezer and the wall.

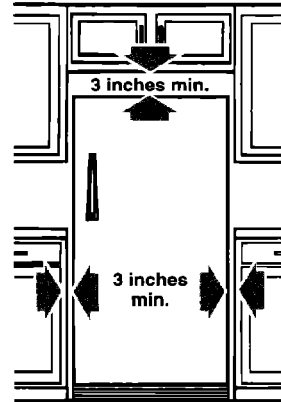

5. If the freezer is to be against a wall, leave extra space on the hinge side so the door can open wider.

Installing the handle

1. Remove screws from front of freezer door and discard.
2. Locate handle assembly kit among packing materials.
3. Attach top of handle to top hole in door with shorter of 2 screws provided.
4. Attach bottom of handle to lower hole in door with longer of 2 screws.

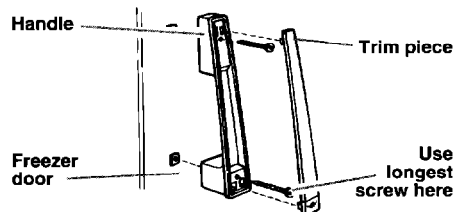

5. Snap trim piece into place.

Completing the installation

1. Locate, remove and discard the 4 bolts that held the freezer in the shipping crate.
2. Locate the 2 front leveling legs taped among the packing materials.
3. Screw these legs into the front holes on the bottom of the freezer. The back of the freezer rests on 2 fixed supports.
4. Adjust the 2 front legs so freezer does not rock.
5. Connect freezer to proper electrical supply and attach retaining clip. (Refer to “Grounding Instructions” section.)

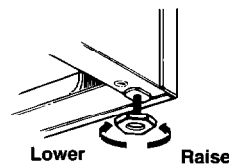

6. Slide freezer into place.
7. Place a leveling tool on top of the freezer—first side to side then front to back. Turn leg counterclockwise to raise a corner. Turn leg clockwise to lower a corner.
8. Repeat Step 7 until the freezer is level.
9. After freezer is fully loaded with food, recheck with level, as in Step 7.

Using Your Freezer

To obtain the best possible results from your freezer, follow the instructions in this section.

Setting the temperature control

Turn the control to 4. This setting is designed to maintain the temperature at or near 0°F (-17.8°C) under normal operating conditions.

Allow the freezer to cool for 6 to 8 hours (be sure to check that it is cooling), and then fill with frozen food. Let the freezer cool overnight before adding large amounts of unfrozen food. Never add more than 2 to 3 pounds (907 - 1,350 g) of unfrozen food per cubic foot of freezer space.

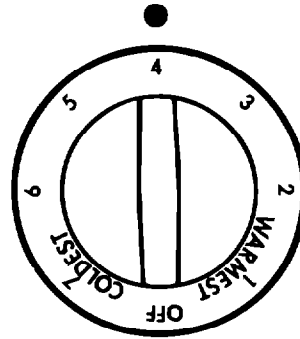

NOTE: When the freezer is first started, the compressor will run constantly until the cabinet is cooled. It may take 6 to 8 hours or longer, depending on room temperature and the number of times the freezer door is opened.

After the cabinet is cooled, the compressor will turn on and off as needed to keep the freezer at the proper temperature.

The outside of your freezer may feel warm. This is normal. The freezer's design and main function is to remove heat from packages and air space inside the freezer. This heat is transferred to the room air, so the outside of the freezer may feel warm.

Adjusting the temperature control

- Turn control to a higher number for colder temperatures.
- Turn control to a lower number for less cold temperatures.

Using the key eject lock (on some models)

⚠ WARNING

Entrapment Hazard

Keep key away from children.

Failure to do so can result in death, suffocation, or frostbite.

If your freezer is equipped with a lock, it can help reduce the hazard of child entrapment.

To lock or unlock the freezer, you must hold the key in the lock while turning. The lock is spring loaded, so the key cannot be left in the lock.

If the key is lost, contact your dealer for a replacement. Always give the complete model and serial number of your freezer when requesting a replacement key.

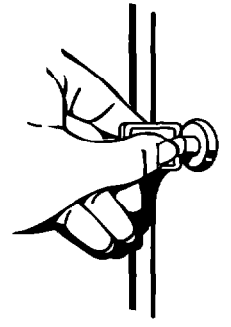

Using the refrigerated shelves (on some models)

Your freezer is equipped with refrigerated interior shelves. Packages in direct contact with the shelves will have the best refrigeration. Fresh, unfrozen food packages should be stored directly on the shelves and not on top of already frozen food packages.

When placing the food packages in your freezer, please remember:

- The cabinet shelves have the best freezing capability. The door shelves and the bottom of the cabinet have a slightly less cold temperature. Therefore, packages sensitive to temperature (meat, poultry, etc.) should not be placed on the door shelves or the freezer bottom.
- Leave some space between the food packages so that cold air can pass over and around them.

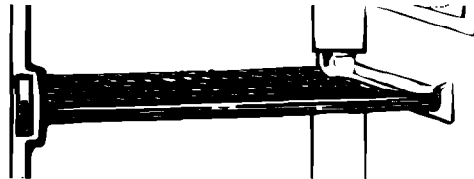

Using the storage gate

To lower storage gate:

1. Lift top of gate up slightly, out of the supports.
2. Pull gate forward and down.

To raise storage gate:

1. Return gate to upright position.
2. Lift top of gate slightly to clear supports.
3. Lower gate into supports.

Pull top up,
then forward.

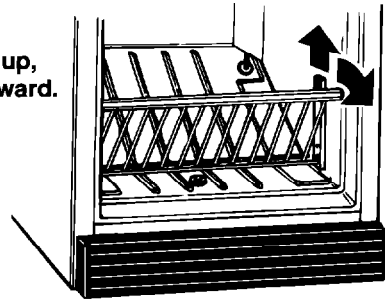

Removing the base grille

For manual defrost models: The base grille will need to be removed when defrosting the freezer.

To remove the grille:

1. Open the door.
2. Pull on both sides of the grille.

To replace the grille:

1. Line up grille support tabs with openings in freezer cabinet.
2. Push firmly to snap grille into place.
3. Close the door.

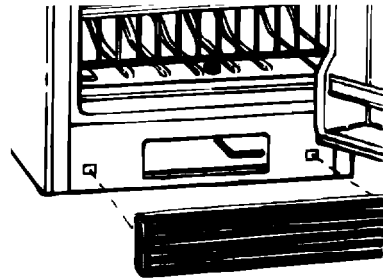

Changing the light bulb (on some models)

To replace interior light:

1. Unplug freezer or disconnect power.
2. Remove the light shield by squeezing sides slightly and pulling out.
3. Replace bulb with 15-watt appliance bulb.
4. Replace light shield. Insert back tabs into slots and squeeze shield slightly to insert front tabs into slots.
5. Plug in freezer or reconnect power.
6. Refer to "Setting the temperature control" section.

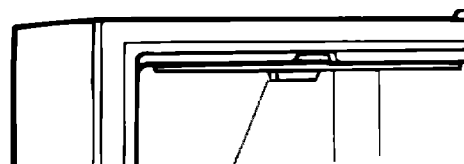

Light shield

Caring For Your Freezer

Your freezer is designed to give you years of dependable service. However, there are a few things you can do to ensure a long product life. This section will tell you how to care for your freezer properly.



Cleaning your frost-free freezer (on some models)

Frost-free means that you will never have to defrost your freezer. Frost is removed by air moving and collecting any moisture and depositing it on the cooling coil. The cooling coil periodically warms up just enough to melt the frost, and it then flows down to the drain pan (located behind the base grille) where it is evaporated.

Complete cleaning should be done at least once a year.

1. Unplug freezer or disconnect power.
2. Remove all frozen food. Wrap frozen food in several layers of newspaper and cover with a blanket. Food will stay frozen for several hours.

OR

Store frozen food in a cooler, additional refrigerator-freezer, or in a cool area.

3. Wash the inside walls with a solution of mild detergent in warm water or 2

tablespoons (26 mg) baking soda to 1 quart (0.95 L) warm water. Do not use abrasive or harsh cleaners.

4. Rinse well and wipe dry with a clean soft cloth.
5. Use a clean sponge or soft cloth and mild detergent in warm water to clean outside of freezer, door liner and gasket.
6. Rinse well and wipe dry with a clean soft cloth.
7. Wax painted metal surfaces outside of freezer to provide rust protection.
NOTE: Do not use wax on plastic parts. Wax may damage them.
8. Replace all frozen food.
9. Plug in freezer or reconnect power.
10. Refer to "Setting the temperature control" section.

Defrosting and cleaning your manual defrost freezer (on some models)

Defrost and clean your freezer when frost has built up to about ¼ inch (6 mm) thickness. Complete defrosting and cleaning should be done at least once a year. In high humidity areas, a freezer may need more frequent defrosting and cleaning. Do not use abrasive cleaners on your freezer. Do not use cleaning waxes, concentrated detergents, bleaches, or cleaners containing petroleum on plastic parts. Damage can occur.

NOTE: The drain cap must be removed before defrosting the freezer, and replaced securely afterward.

1. Unplug freezer or disconnect power.
2. Remove all frozen food. Wrap frozen food in several layers of newspaper and cover with a blanket. Food will stay frozen for several hours.

OR

Store frozen food in a cooler, additional refrigerator-freezer, or in a cool area.

3. **Remove base grille**
(See “Removing base grille” section.)
4. Reach under the unit and pull the drain hose out through the opening. The drain hose carries defrost water out of the freezer, and through the area behind the base grille. Place a large shallow pan under the drain hose. Remove drain cap inside freezer.

NOTE: Check drain pan frequently to avoid water overflow. Have a second pan handy for easier emptying of drain pan.

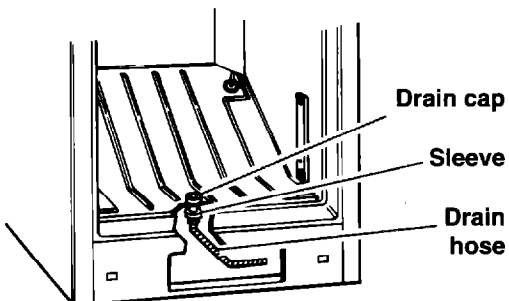

5. **For models with a drain system:**
Reach under the unit to pull the drain hose out through the opening. Place a shallow pan under the drain hose. Remove the drain cap inside the freezer. **NOTE:** Check the drain pan frequently to avoid water overflow. Have a second pan handy for easier emptying of drain pan.
For models without a drain system:
Use a large sponge or plastic baster to remove excess water from the freezer bottom. You might want to have a pan close by to wring the sponge or empty the baster into.
6. Place pans of hot water in freezer with door open to speed melting. Directing air from an electric fan into freezer will also help. Do not place fan or any electrical device in freezer.
7. Use a plastic scraper to remove frost. Do not use an ice pick, knife, or other sharp-pointed tool to defrost freezer. Damage can occur.
8. Wipe water from walls with a towel or sponge.
9. Wash the inside walls with a solution of mild detergent in warm water or 2 tablespoons (26 mg) baking soda to 1 quart (0.95 L) warm water. Do not use abrasive or harsh cleaners.
10. Rinse well and wipe dry with a clean soft cloth.
11. Use a clean sponge or cloth and mild detergent in warm water to clean outside of freezer, door liner, and gasket.
12. Rinse well and wipe dry with a clean soft cloth.
13. Wax painted metal surfaces outside of freezer to provide rust protection. **NOTE:** Do not use wax on plastic parts. Wax may damage them.
14. **For models with a drain system:**
Replace drain hose, drain cap and base grille.
15. Replace all frozen food.
16. Plug in freezer or reconnect power.
17. Refer to “Setting the temperature control” section.

What to do during power outages

- 1. Call the power company.**
Ask how long power will be off.
- 2. Keep freezer closed if service is to be interrupted 24 hours or less.**
This will help food stay frozen.
- 3. If service is to be interrupted longer than 24 hours:**
Remove all frozen food and store in a frozen food locker.

OR

Place 2 lbs. (0.9 kg) of dry ice in freezer for every cubic foot of freezer space. This will keep foods frozen for 2 to 4 days.

OR

If dry ice or a food locker is not available, use or can perishable food at once.

NOTE: A full freezer stays cold longer than a partly filled one. A freezer full of meat stays cold longer than a freezer full of baked goods.

Food containing ice crystals may be safely refrozen, but the quality and flavor of the food may be affected.

Use refrozen food quickly. If the food has been held beyond the recommended storage life, its condition is poor, or you feel it is unsafe to eat, dispose of it immediately.

Food storage information may be found in cookbooks, libraries or with your local county extension agent.

Moving care

Remove all frozen food and pack it in dry ice. Unplug the freezer and clean it thoroughly. Tape the door shut and tape electrical cord to the cabinet.

When you get to your new home, refer to the "Installing Your Freezer" and "Using Your Freezer" sections for information on installation and setting controls.

Troubleshooting

Performance problems often result from little things you can fix without tools. Please read through the chart below before calling for service on your freezer.

PROBLEM	CHECK THE FOLLOWING
Freezer stops running	<ul style="list-style-type: none">• Is the power cord plugged into a live circuit with the proper voltage?• Is there a blown fuse or tripped circuit breaker?• Has local power failed?• Is the Temperature Control set to a numbered setting?
Motor seems to run too long	<ul style="list-style-type: none">• Is there excessive frost or is a package preventing the door from closing? Defrost and clean freezer, or move package so door closes properly.• Has a large amount of unfrozen food been added to the freezer? The motor will naturally run longer. Add no more unfrozen food at one time than will freeze in 24 hours – approximately 2-3 lbs. per cubic foot of freezer space.• Is the day hot and muggy or the room too warm? The motor will naturally run longer to provide the correct amount of cooling.• Is there enough air circulation space around the freezer? See “Choosing the proper location” on page 7.
The freezer clicks but does not run	<ul style="list-style-type: none">• The local power has failed. Unplug the freezer for 30 minutes to allow the refrigeration system to equalize. During this time, keep the door closed whenever possible.

Requesting Assistance or Service

Before calling for assistance or service, please check the "Troubleshooting" section. It may save you the cost of a service call. If you still need help, follow the instructions below.

1. If you need assistance* ...

Call the Whirlpool Consumer Assistance Center telephone number. Dial free from anywhere in the U.S.A.:



1-800-253-1301

and talk with one of our trained consultants. The consultant can instruct you in how to obtain satisfactory operation from your appliance or, if service is necessary, recommend a qualified service company in your area.

If you prefer, write to:

Whirlpool Brand Home Appliances
Consumer Assistance Center
c/o Correspondence Dept.
Whirlpool Corporation
2000 North M-63
Benton Harbor, MI 49022-2692

Please include a daytime phone number in your correspondence.

2. If you need service* ...



Whirlpool has a nationwide network of authorized service companies. Whirlpool service technicians are trained to fulfill the product warranty and

provide after-warranty service, anywhere in the United States. To locate the authorized Whirlpool service company in your area, call our Consumer Assistance Center telephone number (see Step 1) or look in your telephone directory Yellow Pages under:

**• APPLIANCE-HOUSEHOLD-
MAJOR, SERVICE & REPAIR**

- See: Whirlpool Appliances or
Authorized Whirlpool Service
(Example: XYZ Service Co.)

**• WASHING MACHINES &
DRYERS, SERVICE & REPAIR**

- See: Whirlpool Appliances or
Authorized Whirlpool Service
(Example: XYZ Service Co.)

3. If you need FSP® replacement parts ...

FSP is a registered trademark of Whirlpool Corporation for quality parts. Look for this symbol of quality whenever you need a replacement part for your WHIRLPOOL® appliance. FSP replacement parts will fit right and work right because they are made to the same exacting specifications used to build every new WHIRLPOOL appliance.

To locate FSP replacement parts in your area, refer to Step 2 or call the Whirlpool Consumer Assistance Center number in Step 1.

* When asking for help or service:

Please provide a detailed description of the problem, your appliance's complete model and serial numbers, and the purchase date. (See "A Note To You" section.) This information will help us respond properly to your request.

WHIRLPOOL®

Domestic Freezer Warranty

LENGTH OF WARRANTY	WHIRLPOOL WILL PAY FOR
FULL ONE-YEAR WARRANTY FROM DATE OF PURCHASE	FSP® replacement parts and repair labor to correct defects in materials or workmanship. Service must be provided by an authorized Whirlpool service company.
FULL FIVE-YEAR WARRANTY FROM DATE OF PURCHASE	FSP replacement parts and repair labor to correct defects in materials or workmanship in the sealed refrigeration system. Service must be provided by an authorized Whirlpool service company. These parts are: 1. Compressor 4. Drier 2. Evaporator 5. Connecting Tubing 3. Condenser
WHIRLPOOL WILL NOT PAY FOR	
<p>A. Service calls to:</p> <ol style="list-style-type: none"> 1. Correct the installation of the freezer. 2. Instruct you how to use the freezer. 3. Replace house fuses or correct house wiring or plumbing. 4. Replace light bulbs or batteries. <p>B. Pickup and delivery. This product is designed to be repaired in the home.</p> <p>C. Damage to freezer caused by accident, misuse, fire, flood, acts of God, or use of products not approved by Whirlpool.</p> <p>D. Food loss coverage for freezers used in commercial applications.</p> <p>E. Repairs to parts or systems resulting from unauthorized modifications made to the appliance.</p>	

11/97

Limited domestic food loss coverage. See below for details on limited domestic food loss protection plan.

WHIRLPOOL CORPORATION SHALL NOT BE LIABLE FOR INCIDENTAL OR CONSEQUENTIAL DAMAGES. Some states do not allow the exclusion or limitation of incidental or consequential damages so this exclusion or limitation may not apply to you. This warranty gives you specific legal rights, and you may also have other rights which vary from state to state.

Outside the United States, a different warranty may apply. For details, contact your authorized Whirlpool dealer.

LIMITED DOMESTIC FOOD LOSS COVERAGE REIMBURSEMENT FOR FOOD LOSSES.

During the first year of ownership, the WHIRLPOOL® Freezer warranty provides reimbursement as stated below for food actually spoiled while stored in the freezer as a result of defects in materials or workmanship.

During the second through fifth years of ownership, reimbursement will be made as stated below for food actually spoiled while stored in the freezer as a result of a **FAILURE OF THE SEALED REFRIGERATION SYSTEM.**

Food spoilage losses must be verified by Whirlpool or an authorized Whirlpool service company. Reimbursement of losses will be based on domestic use and freezer size up to the total cumulative amount shown for the five-year warranty period.

- 14.9 cubic feet or smaller up to \$100.00 maximum payment
- 15.0 cubic feet or larger up to \$150.00 maximum payment

The reimbursement amounts shown may or may not cover the actual replacement cost of the contents of your freezer. They are, however, the maximum payments that will be paid, and they are cumulative for the five-year warranty period.

Sorry, but Whirlpool is not responsible for food losses caused by natural spoilage, misuse, or negligent care of the freezer, or by accidental or intentional disconnecting of the electrical power cord, power interruption, inadequate power, fire damage, water damage, theft, riots, strikes, war, or acts of God.

If you need service, first see the "Troubleshooting" section of this book. After checking "Troubleshooting," additional help can be found by checking the "Requesting Assistance or Service" section or by calling our Consumer Assistance Center telephone number, **1-800-253-1301**, from anywhere in the U.S.A.