

**CAUTION: DISCONNECT ELECTRIC CURRENT BEFORE SERVICING. LABEL ALL WIRES PRIOR TO DISCONNECTION WHEN SERVICING CONTROLS. WIRING ERRORS CAN CAUSE IMPROPER AND DANGEROUS OPERATION. VERIFY PROPER OPERATION AFTER SERVICING.**

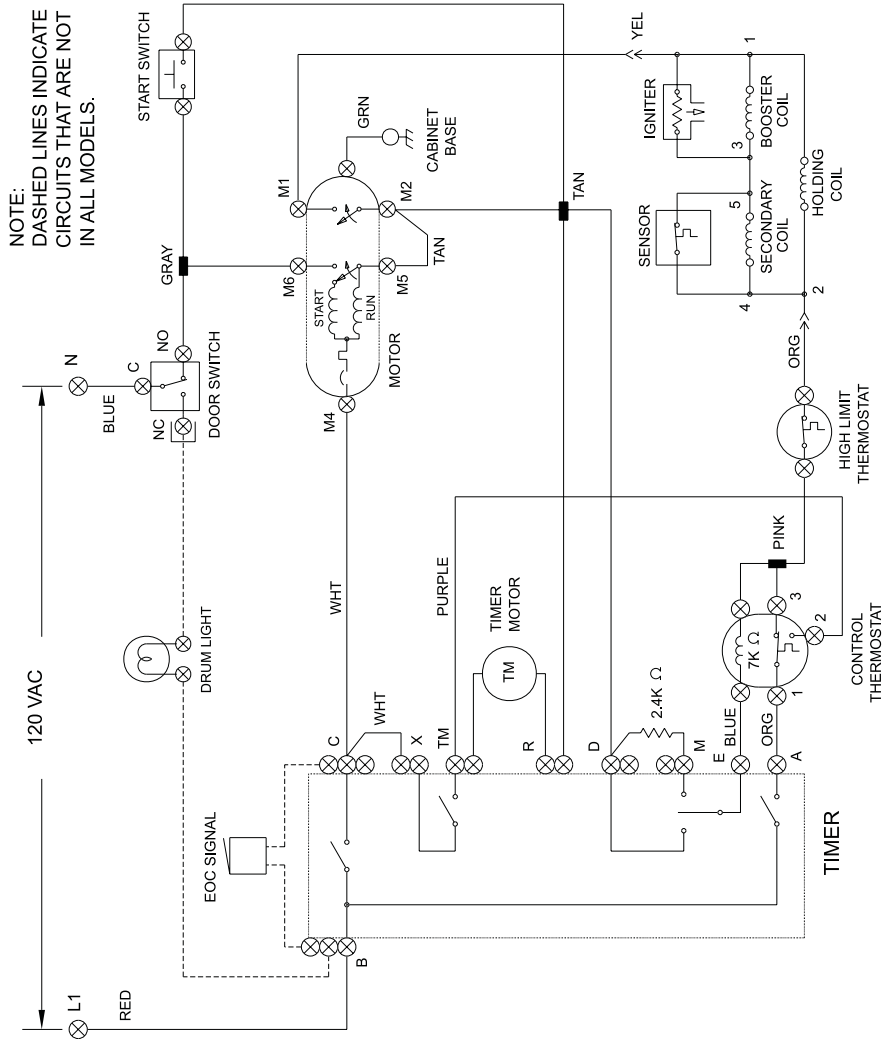

| WIRING CODES |                            |
|--------------|----------------------------|
|              | QUICK DISCONNECT TERMINAL  |
|              | CONNECTION                 |
|              | NO CONNECTION              |
|              | MOTOR SWITCH               |
|              | SPLICE                     |
|              | MOTOR PROTECTOR            |
|              | CHASSIS (CABINET) GROUND   |
|              | SCREW TERMINAL             |
|              | HARNESS CONNECTOR TERMINAL |
|              | INSULATED TERMINAL         |

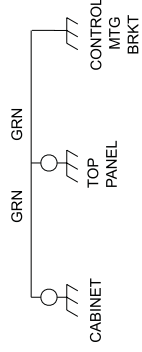

**NOTES:**

1. ALL WIRING MUST CONFORM TO LOCAL ELECTRICAL CODES.
2. CONNECT DRYER TO A 15 AMPERE INDIVIDUAL BRANCH CIRCUIT.
3. TIMER SHOWN IN OFF POSITION, DOOR SWITCH CLOSED, MOTOR AT REST & THERMOSTAT CLOSED.

| CIRCUIT          | AUTO DRY |    | TIMED DRY (MIN) |    |     | KNIT CYCLE |    |
|------------------|----------|----|-----------------|----|-----|------------|----|
|                  | 30       | 20 | 10              | 0  | OFF | 0          | 0  |
| HEATER B-A       | ON       | ON | ON              | ON | ON  | ON         | ON |
| TIMER MOTOR X-TM | ON       | ON | ON              | ON | ON  | ON         | ON |
| MOTOR B-C        | ON       | ON | ON              | ON | ON  | ON         | ON |
| MED HEAT E-M     | ON       | ON | ON              | ON | ON  | ON         | ON |
| LOW HEAT E-D     | ON       | ON | ON              | ON | ON  | ON         | ON |

BAR CHART TO THE LEFT REPRESENTS ONE COMPLETE REVOLUTION OF TIMER SHAFT.

SHADED PORTION OF BAR CHART INDICATES THE PROPORTIONAL TIMES THAT INTERNAL TIMER CONTACTS ARE CLOSED.