

WARNING

- Dryer must be properly grounded at all times.
- Vent dryer through free-flowing, outdoor-vented, metal duct system.
- Improper gas installation or LP conversion could result in injury or even death.
- Avoid back or other injury. Use more than one person to move, tip or lift the dryer.

IMPORTANT

Please read all safety instructions before using your new front-loading dryer. For best washing results with your new dryer, remember to review:

- ✓ **INSTALLATION INSTRUCTIONS**
- ✓ **USE & CARE GUIDE**

NOTE TO INSTALLER

Leave these instructions with the customer.

NOTA AL INSTALADOR

Deje estas instrucciones con el cliente.

Español continua en la página trasera.

REMARQUE POUR L'INSTALLATEUR

Laissez ces instructions au client.

Suite de la version française au verso.

1 UNPACKING & HANDLING

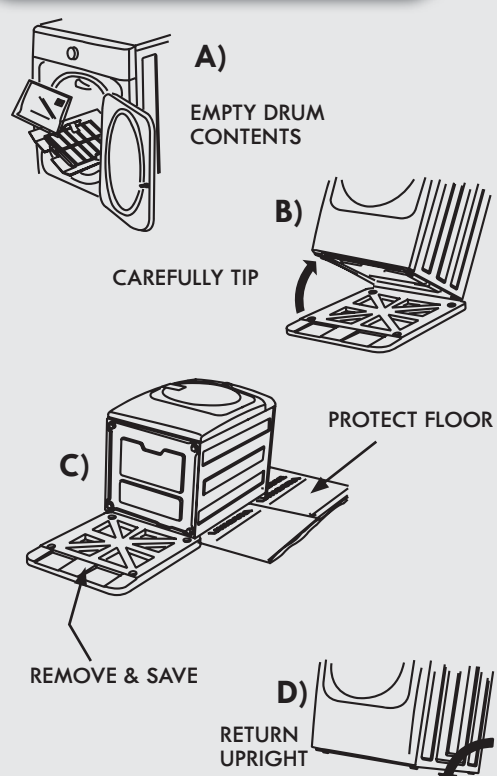

2 VENT EXHAUST

- USE ONLY 4 INCH (102 mm) RIGID METAL OR SEMI-RIGID METAL DUCTING
- REPLACE PLASTIC OR FOIL DUCTS WITH METAL
- CLEAN LINT FROM PRESENT DUCT SYSTEM BEFORE ADDING ON
- SEE CHART TO THE RIGHT FOR ACCEPTABLE NUMBER OF 90° TURNS IN SYSTEM
- DO NOT USE SCREWS TO CONNECT DUCTS
- DO NOT USE REGULAR DUCT TAPE TO CONNECT DUCTS, ONLY METAL FOIL TAPE
- 4" (102 mm) CLAMP RECOMMENDED FOR CONNECTION BETWEEN DRYER & EXHAUST SYSTEM
- EXHAUST SYSTEM MUST BE VENTED OUTSIDE WITH APPROVED VENT HOOD

- TO VENT LEFT OR RIGHT FROM DRYER, USE 90° QUICK-TURN ELBOW
- FOR INSTALLATION IN A RECESSED AREA OR CLOSET, SEE COMPLETE INSTALLATION INSTRUCTIONS
- FOR MOBILE HOME INSTALLATION, SEE COMPLETE INSTALLATION INSTRUCTIONS

Number of 90° turns	MAXIMUM LENGTH of 4" (102 mm) Rigid Metal Duct	
	VENT HOOD TYPE	
	(Preferred)	
0	125 ft. (38.0m)	110 ft. (33.5m)
1	115 ft. (35.0m)	100 ft. (30.5m)
2	105 ft. (32.0m)	90 ft. (27.5m)
3	95 ft. (29.0m)	80 ft. (24.5m)
4	85 ft. (26.0m)	70 ft. (21.5m)

*Do not install plastic or foil ducting. If installing semi-rigid ducting, do not exceed 8 ft (2.4 m) total duct length.

IMPORTANT
For pedestal, stacked or closet installations, see detailed installation instructions enclosed.

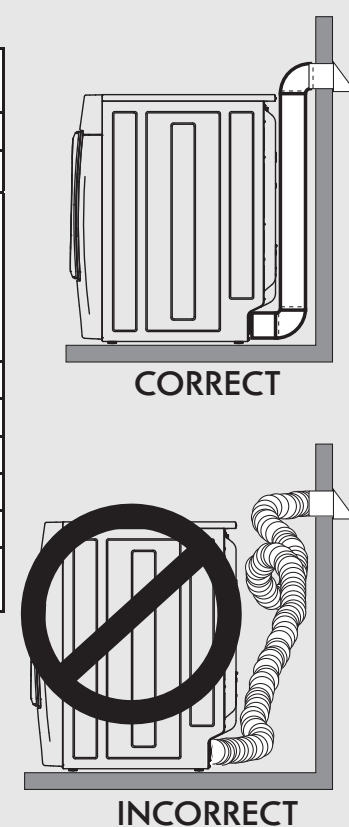

3 HEAT SOURCE

GAS DRYER

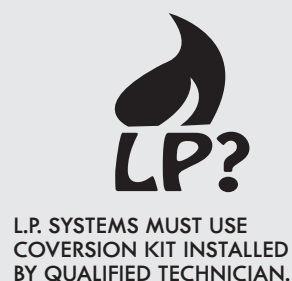

ELECTRIC DRYER

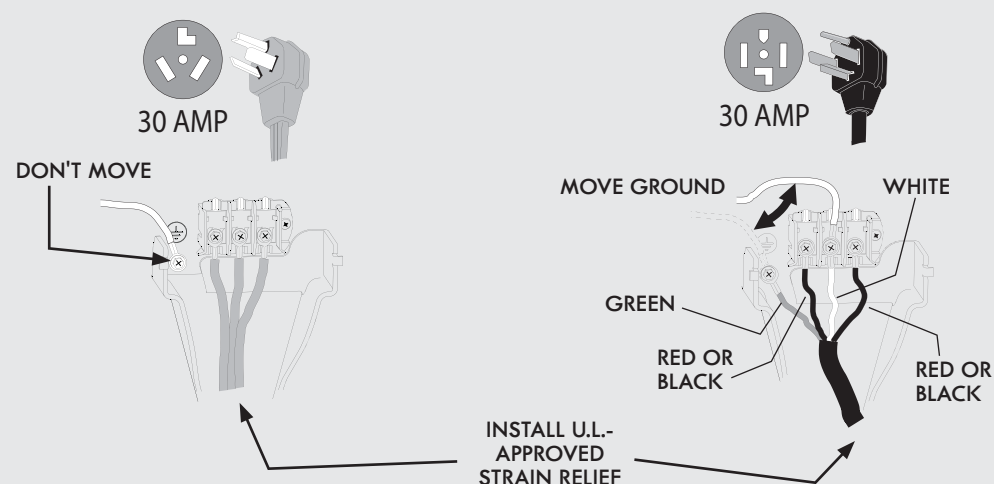

4 CONNECT WATER

IF THIS IS NOT A STEAM DRYER, SKIP TO STEP 5.

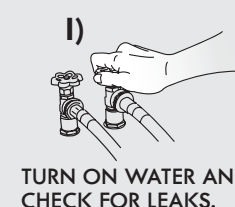
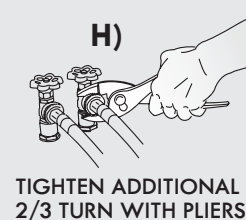
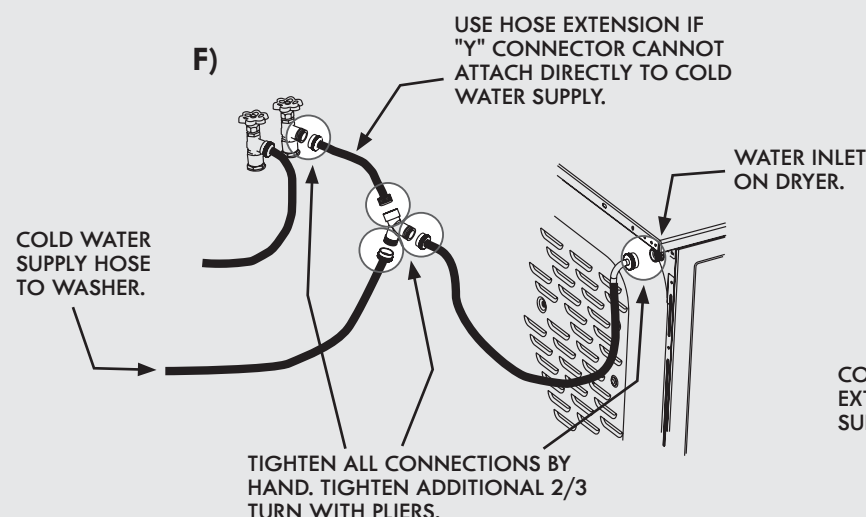
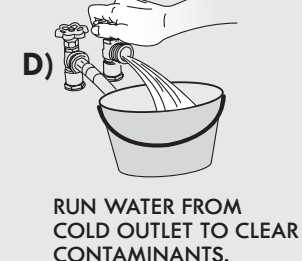
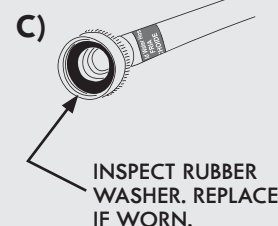
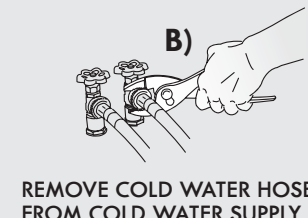
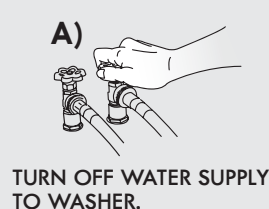

5 LEVEL & CONNECT

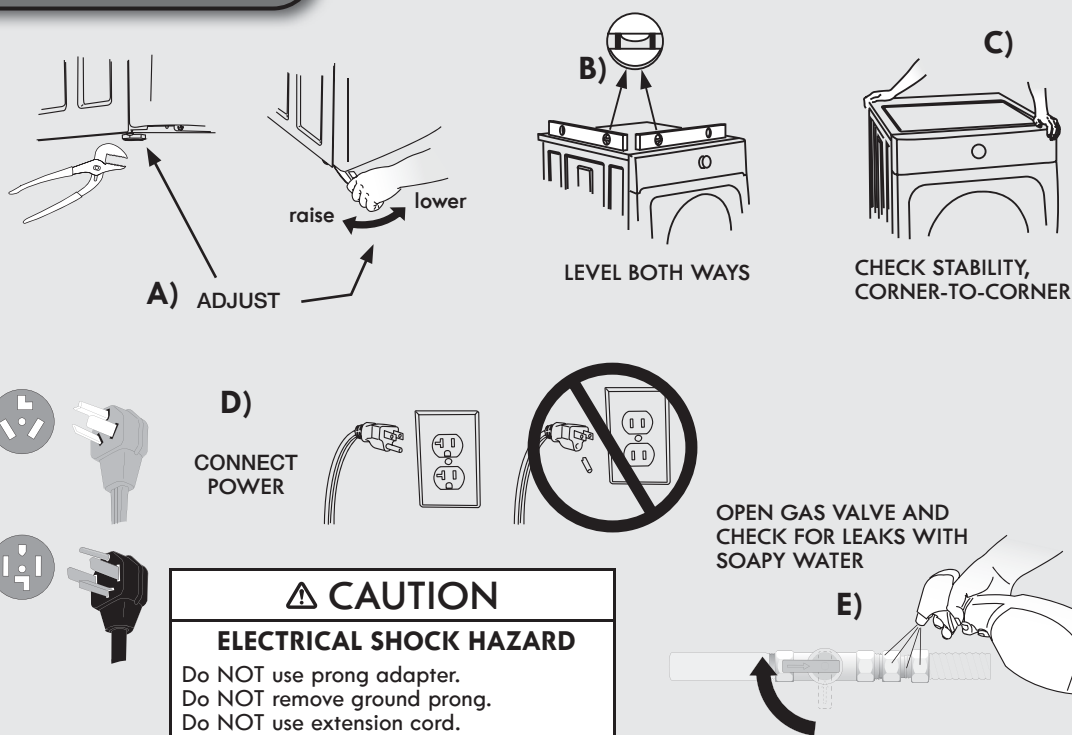

CAUTION

ELECTRICAL SHOCK HAZARD
Do NOT use prong adapter.
Do NOT remove ground prong.
Do NOT use extension cord.

6 OPERATE

Perform brief installation cycle for your model as follows:

If dryer has this console:

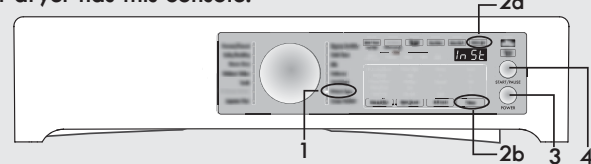

1. Empty dryer's drum and close door.
2. After you plug in the dryer the first time: wake up the dryer by pressing the **POWER** button (3), rotate cycle knob to position shown above (1), and within 10 seconds, immediately and simultaneously press and hold both buttons shown above (2a and 2b) for 5 seconds.
3. The LED window will display **In St** (Install) and show estimated time of cycle completion. Press the **START** button (4). The **Installation Cycle** will automatically perform various diagnostic routines. At cycle completion, the LCD window may display **In St** → **PAS** (Install Pass), meaning your new dryer is properly installed and ready for use. If it prompts an action such as **Srv** → **Err** (Service Cord), **no** → **Gas** (No Gas), or **Err** → **Srv** (Call Service - 1-800-4-MY-HOME), review the installation steps and make the necessary corrections before you attempt to use the dryer.
4. Your dryer will exit the **Installation Cycle** and return to normal operation the next time you wake it up.
5. Please read the **Use & Care Guide** and enjoy your new premium dryer!

If dryer has this console:

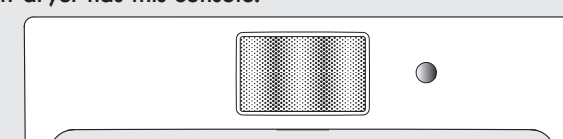

1. After you plug in the dryer the first time, the dryer will power up on its own. It will take approximately one minute for the LCD to perform initial boot up procedures. Then follow the prompts on the touch screen LCD, including language selection.
2. The Installation Cycle will automatically perform various diagnostic routines. At cycle completion, the LCD window may display **INSTALL PASS!**, meaning your new dryer is properly installed and ready for use. If it prompts an action such as **SERVICE CORD**, **NO GAS**, or **CALL SERVICE** - 1-800-4-MY-HOME, review the installation steps and make the necessary corrections before you attempt to use the dryer.
3. Your dryer will exit the **Installation Cycle** and return to normal operation the next time you wake it up.
4. Please read the **Use & Care Guide** and enjoy your new premium dryer!

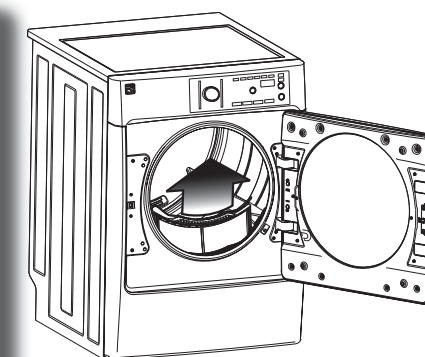

CLEAN LINT FILTER AFTER EVERY LOAD.

LIMPIE EL FILTRO DE PELUSAS DESPUÉS DE CADA CARGA.

NETTOYEZ LE FILTRE À CHARPIE APRÈS CHAQUE SÉCHAGE.

