

SERVICE DATA SHEET

Gas Range with ES 535/585 Electronic Oven Control

NOTICE - This service data sheet is intended for use by persons having electrical and mechanical training and a level of knowledge of these subjects generally considered acceptable in the appliance repair trade. The manufacturer cannot be responsible, nor assume any liability for injury or damage of any kind arising from the use of this data sheet.

SAFE SERVICING PRACTICES

To avoid the possibility of personal injury and/or property damage, it is important that safe servicing practices be observed. The following are examples, but without limitation, of such practices.

- Before servicing or moving an appliance remove power cord from electrical outlet, trip circuit breaker to OFF, or remove fuse.
- Never interfere with the proper installation of any safety device.
- GROUNDING:** The standard color coding for safety ground wires is *GREEN* or *GREEN WITH YELLOW STRIPES*. Ground leads are not to be used as current carrying conductors. **It is extremely important that the service technician reestablish all safety grounds prior to completion of service. Failure to do so will create a potential safety hazard.**
- Prior to returning the product to service, ensure that:
 - All electric connections are correct and secure.
 - All electrical leads are properly dressed and secured away from sharp edges, high-temperature components, and moving parts.
 - All uninsulated electrical terminals, connectors, heaters, etc. are adequately spaced away from all metal parts and panels.
 - All safety grounds (both internal and external) are correctly and securely reassembled.

Oven Calibration

Set the electronic oven control for normal baking at 350°F. Obtain an average oven temperature after a minimum of 5 cycles. Press **STOP** or **CLEAR** keypad to end Bake mode.

Temperature Adjustment

- While in a non-cooking mode, press and hold the **BAKE** key pad for 6 seconds.
- The current calibration offset (temperature adjustment) should appear in the temperature display.
- Use the number key pads (0-9) to enter the desired amount of adjustment (up to 35°F).
- Press the **CLEAN** key pad to change the sign of the adjustment to a (-) if necessary. A positive adjustment will not display a sign.
- Once the desired adjustment (-35° to 35° F) has been entered, press the **START** key pad to accept the change or the **STOP** or **CLEAR** key pad to reject the change.

Note: Changing calibration affects all Baking modes. The adjustments made will not change the self-cleaning temperature.

Electronic Oven Control & Jumper Connections (EOC Rear View)

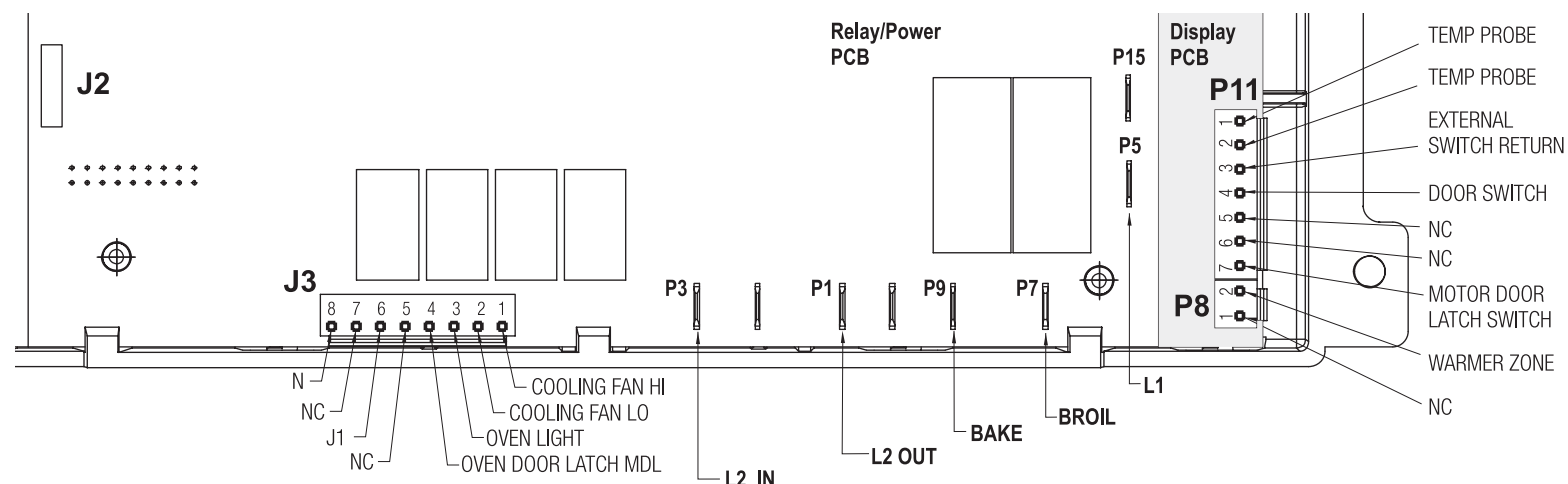

IMPORTANT
DO NOT REMOVE THIS BAG
OR DESTROY THE CONTENTS
 WIRING DIAGRAMS AND SERVICE
 INFORMATION ENCLOSED
REPLACE CONTENTS IN BAG

p/n 316519821 (0608) EN

Resistance Temperature Detector (RTD)

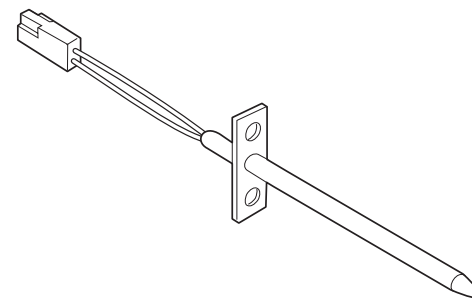

Resistance Temperature Detector Scale

RTD SCALE	
Temperature (°F)	Resistance (ohms)
32 ± 1.9	1000 ± 4.0
75 ± 2.5	1091 ± 5.3
250 ± 4.4	1453 ± 8.9
350 ± 5.4	1654 ± 10.8
450 ± 6.9	1852 ± 13.5
550 ± 8.2	2047 ± 15.8
650 ± 9.6	2237 ± 18.5
900 ± 13.6	2697 ± 24.4

Electronic Oven Control Fault Code Descriptions

Fault Code	Likely Failure Condition/Cause	Suggested Corrective Action
F10	Runaway Temperature.	1. (F10 only) Check RTD Sensor Probe & replace if necessary. If oven is overheating, disconnect power. If oven continues to overheat when the power is reapplied, replace EOC. Severe overheating may require the entire oven to be replaced should damage be extensive. 2. (F11, 12 & 13) Disconnect power, wait 30 seconds and reapply power. 3. (F11, 12 & 13) If fault returns upon power-up, replace EOC.
F11	Shorted Keypad.	
F12	Bad Micro Identification.	
F13	Bad EEPROM Identification/Checksum error.	
F15	Internal Control or Power Supply failure between Power Supply Board & EOC.	1. Check harness connectors at P2 on (Power Supply Board) & J2 connectors on (EOC). 2. If harness and connections are good replace (Power Supply Board). 3. If Power Supply Board is good replace (EOC).
F20	Communication failure between EOC & ESEC system (for electric range models ONLY)	1. Test harness/connections P4 (EOC) & P7 (Surface Element Control Board) 2. If harness checks O.K. failure can be caused by faulty UIB, Surface Element Control Board or EOC.
F26	Communication failure with Mini Oven Control Board. (for models equipped with Bake-n-Warm™ ONLY)	1. Check harness & connectors from the EOC to Mini Oven Control Board. Check for 15VDC to Mini Oven Control Board (red & gray wires). If harness and voltage are good replace Mini Oven Control Board. If fault returns replace the EOC.
F30	Open Probe or connection.	1. (F30 or F31) Check resistance at room temperature & compare to RTD Sensor resistance chart. If resistance does not match the RTD chart replace RTD Sensor Probe. Check Sensor wiring harness between EOC & Sensor Probe connector. 2. (F30 or F31) Check resistance at room temperature, if less than 500 ohms, replace RTD Sensor Probe. Check for shorted Sensor Probe harness between EOC & Probe connector.
F31	Shorted Probe or connection.	
F90	Maximum oven door unlock time exceeded.	1. (F90, 91, 92, 93 & 94) Check the wiring between EOC & Lock Motor Micro Switch. 2. (F90, 91, 92, 93 & 94) Replace the Motor Door Latch assembly if necessary. 3. (F90, 91, 92, 93 & 94) Check for binding of the Latch Cam, Lock Motor Rod & Lock Motor Cam. 4. (F90, 91, 92, 93 & 94) Check to see if Lock Motor Coil is open. If open, replace Lock Motor Assembly. 5. (F90, 91, 92, 93 & 94) Lock Motor continuously runs - if Micro Switch is open, replace Lock Motor Assembly. 6. (F92, 93 & 94) Check oven door Light Switch - if open, replace Switch. 7. If all situations above do not solve problem, replace EOC.
F91	Maximum oven door unlock attempts exceeded.	
F92	Maximum oven door open time exceeded.	
F93	Maximum oven door lock time exceeded.	
F94	Maximum oven door lock attempts exceeded.	

Circuit Analysis Matrix

	EOC Relays					
	L1 to Bake	L1 to Broil	L1 to Motor Door Latch	L1 to Conv/Speed Bake Fan	Door Switch COM-NO	Warmer Drawer Lock Switch (Motor Door Latch)
Bake/Time Bake	X	X*				X
Conv/Speed Bake	X	X*		X		X
Broil		X				X
Clean	X					
Unlocked						X
Locking			X			X
Locked						
Unlocking			X			X
Door Open						
Door Closed					X	
Cooktop Active						

Note: X=Check listed circuits. *=Alternates with Bake element.

General Troubleshooting Diagram

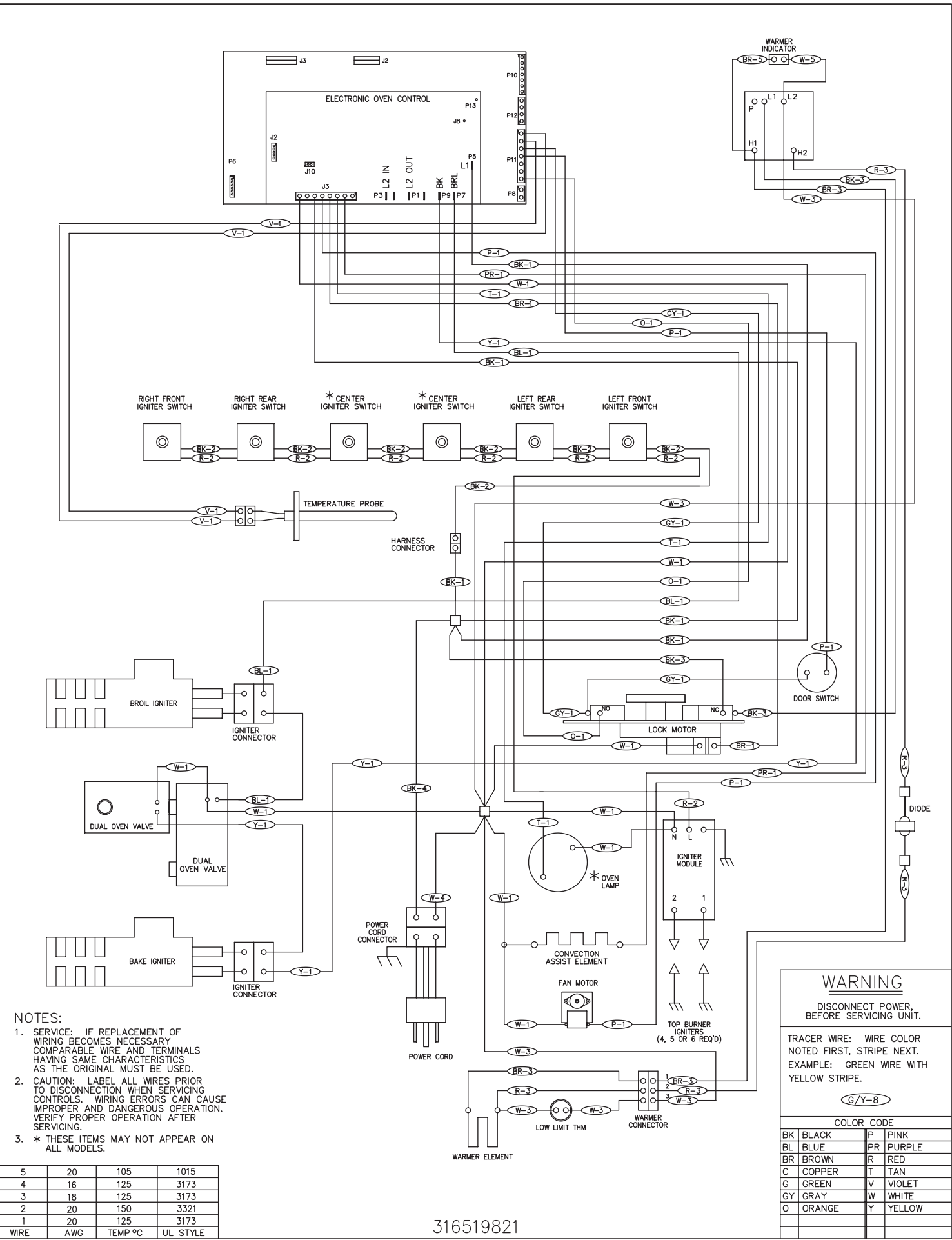

316519821

General Troubleshooting Schematic

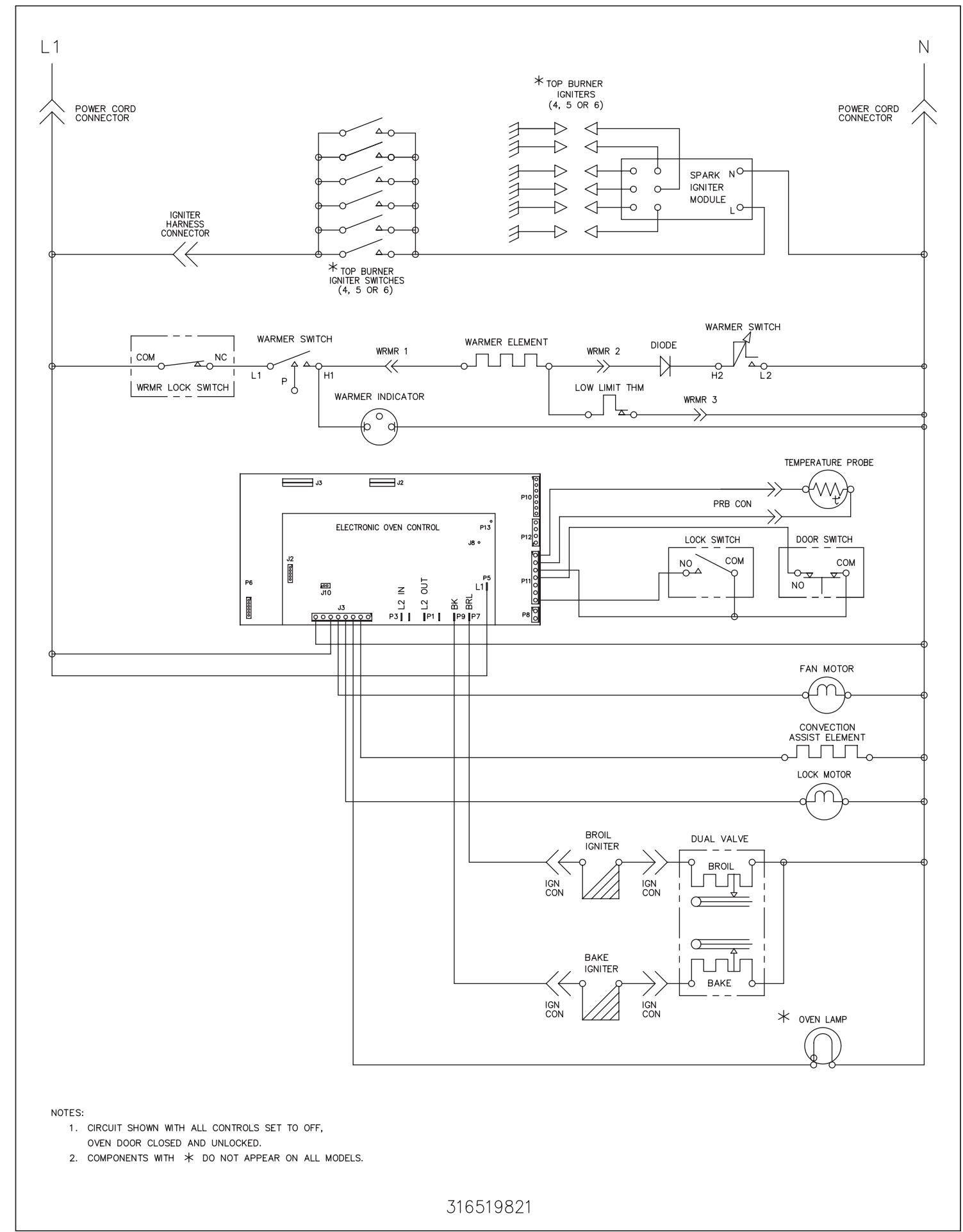

316519821