

SERVICE DATA SHEET

Electric Ranges with ES 100/105 Electronic Oven Control

NOTICE - This service data sheet is intended for use by persons having electrical and mechanical training and a level of knowledge of these subjects generally considered acceptable in the appliance repair trade. The manufacturer cannot be responsible, nor assume any liability for injury or damage of any kind arising from the use of this data sheet.

SAFE SERVICING PRACTICES

To avoid the possibility of personal injury and/or property damage, it is important that safe servicing practices be observed. The following are examples, but without limitation, of such practices.

- Before servicing or moving an appliance remove power cord from electrical outlet, trip circuit breaker to OFF, or remove fuse.
- Never interfere with the proper installation of any safety device.
- GROUNDING:** The standard color coding for safety ground wires is *GREEN* or *GREEN WITH YELLOW STRIPES*. Ground leads are not to be used as current carrying conductors. **It is extremely important that the service technician reestablish all safety grounds prior to completion of service. Failure to do so will create a potential safety hazard.**
- Prior to returning the product to service, ensure that:
 - All electric connections are correct and secure.
 - All electrical leads are properly dressed and secured away from sharp edges, high-temperature components, and moving parts.
 - All uninsulated electrical terminals, connectors, heaters, etc. are adequately spaced away from all metal parts and panels.
 - All safety grounds (both internal and external) are correctly and securely reassembled.

Oven Calibration

Set the electronic oven control for normal baking at 350°F. Obtain an average oven temperature after a minimum of 5 cycles. Press **CANCEL** or **CLEAR OFF** to end bake mode.

Electronic Oven Control (E.O.C.) Connections (J1)

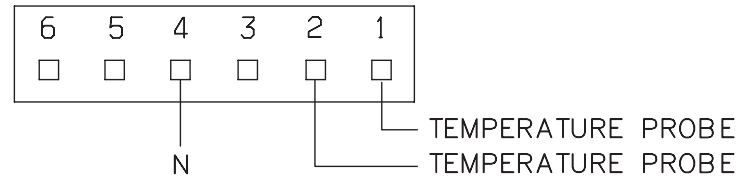

Oven Temperature Adjustment (some models)

- Press & hold the **BAKE** key pad and release after the display shows the factory temperature setting of 00. If the oven temperature has been previously adjusted from the factory setting, the latest adjusted value will appear in the display instead.
- You may increase the oven temperature in 5°F increments with each press of the **UP ARROW** key pad. You may also adjust the oven temperature downward in 5°F increments with each press of the **DOWN ARROW** keypad (total adjustment range is +35°F to -35° F).
- To accept the change, wait until the oven control provides the acceptance beep (**See important notes**).
- The oven temperature adjustment has been made by the oven control and the display will return to the time of day.

Important notes:

- The oven temperature adjustment may be made if your oven control has been set for °C (Celsius) temperature display mode. In this case each press of the **UP ARROW** or **DOWN ARROW** key pad will adjust in 1°C increments upward (maximum +18°C) or downward (maximum -18°C), depending on which arrow keypad is pressed.
- If at any time during the process of adjusting the oven temperature feature you decide not to make the change, press the **CANCEL** or **CLEAR OFF** key pad once before the acceptance beep.
- The oven temperature adjustment feature can not be modified if **BAKE** or **BROIL** is active.

Resistance Temperature Detector Scale

RTD SCALE	
Temperature (°F)	Resistance (ohms)
32 ± 1.9	1000 ± 4.0
75 ± 2.5	1091 ± 5.3
250 ± 4.4	1453 ± 8.9
350 ± 5.4	1654 ± 10.8
450 ± 6.9	1852 ± 13.5
550 ± 8.2	2047 ± 15.8
650 ± 9.6	2237 ± 18.5
900 ± 13.6	2697 ± 24.4

Resistance Temperature Detector

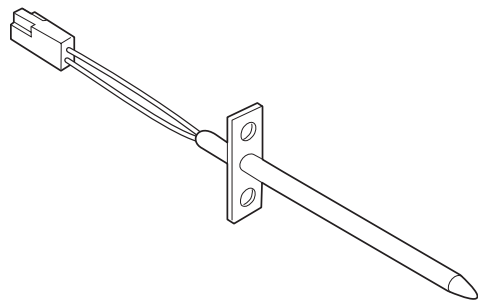

Electronic Oven Control (E.O.C. Rear View)

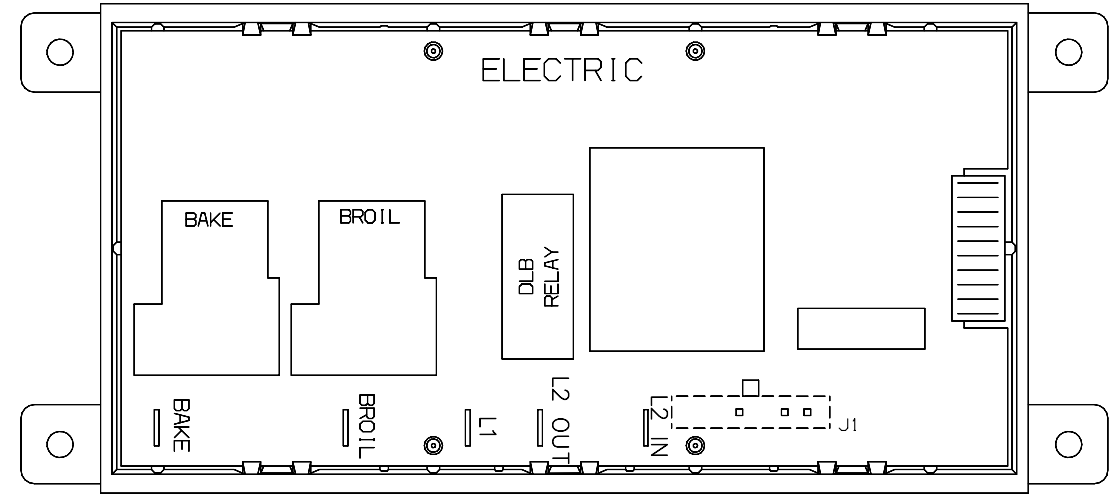

Electronic Oven Control (E.O.C.) Fault Code Descriptions (models that display F1 or F3)

Note: Only two fault codes are displayed by this control - **F1** or **F3**. Generally, **F1** display implies the electronic oven control itself has detected an internal malfunction. **F3** implies the control has detected a sensor probe failure. In either case, an alarm will accompany a displayed **F1** or **F3**.

Fault Code	Likely Failure Condition/Cause	Suggested Corrective Action
F1	<ol style="list-style-type: none"> Shorted keypad. Control's internal checksum may have become corrupted. Control has sensed a potential runaway oven condition. Control may have shorted relay, RTD sensor probe may have gone bad. 	<ol style="list-style-type: none"> Disconnect power, wait 30 seconds and reapply power. If fault returns upon power-up, replace EOC. Check RTD sensor probe and replace if necessary. If oven is overheating, disconnect power. If oven continues to overheat when the power is reapplied, replace EOC. Severe overheating may require the entire oven to be replaced, should damage be extensive. Replace EOC.
F3	<ol style="list-style-type: none"> Open RTD sensor probe. Note: The EOC will initially display an F1 for this condition. The EOC thinks a runaway oven condition exists. Shorted RTD sensor probe. Note: The F3 for shorted probe should only occur when the oven is active or when an attempt is made to enter a mode. 	<ol style="list-style-type: none"> Check resistance at room temperature and compare to RTD sensor resistance chart. If resistance does not match the chart, replace RTD sensor probe. Check resistance at room temperature, if less than 500 ohms, replace RTD sensor probe.

Electronic Oven Control (E.O.C.) Fault Code Descriptions (models that display F10, F11, F13, F30 or F31)

Fault Code	Likely Failure Condition/Cause	Suggested Corrective Action
F10	Runaway temperature.	<ol style="list-style-type: none"> (F10 only) Check RTD Sensor Probe & replace if necessary. If oven is overheating, disconnect power. If oven continues to overheat when the power is reapplied, replace EOC. Severe overheating may require the entire oven to be replaced should damage be extensive. (F11 & 13) Disconnect power, wait 30 seconds and reapply power. (F11 & 13) If fault returns upon power-up, replace EOC.
F11	Shorted keypad.	
F13	Bad micro identification.	
F13	Bad EEPROM identification/checksum error.	<ol style="list-style-type: none"> (F30 or F31) Check resistance at room temperature & compare to RTD Sensor resistance chart. If resistance does not match the RTD chart replace RTD Sensor Probe. Check Sensor wiring harness between EOC & Sensor Probe connector. (F30 or F31) Check resistance at room temperature, if less than 500 ohms, replace RTD Sensor Probe. Check for shorted Sensor Probe harness between EOC & Probe connector.
F30	Open probe connection.	
F31	Shorted probe connection.	

Circuit Analysis Matrix

	EOC Relays		
	L1 to Bake	L1 to Broil	Door Switch COM-NC
Bake	X	X*	
Broil		X	
Door Open			X
Door Closed			

Note: X=Check listed circuits. *=Alternates with Bake element.

IMPORTANT
DO NOT REMOVE THIS BAG
OR DESTROY THE CONTENTS
 WIRING DIAGRAMS AND SERVICE
 INFORMATION ENCLOSED
REPLACE CONTENTS IN BAG

GENERAL TROUBLESHOOTING DIAGRAM

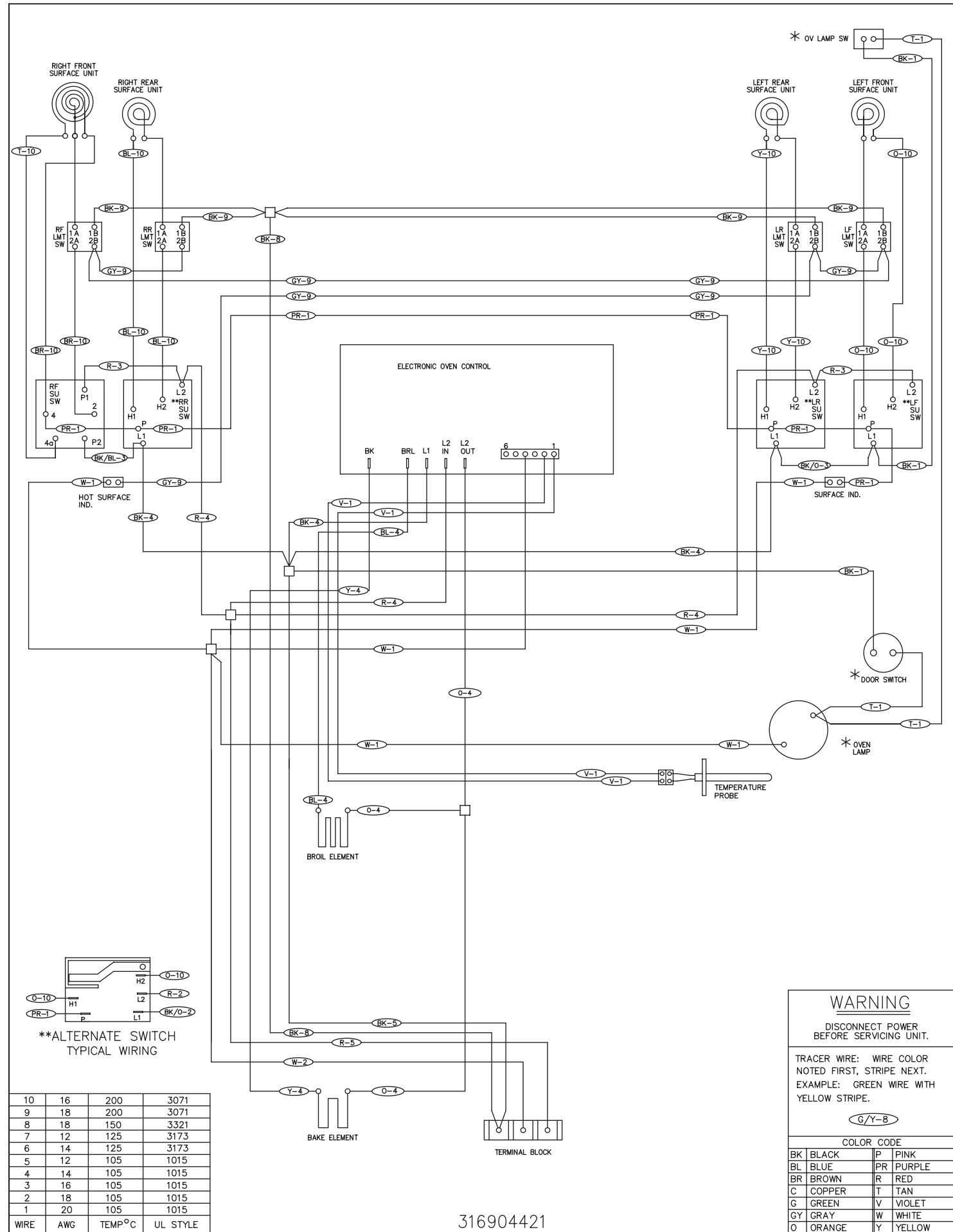

GENERAL TROUBLESHOOTING SCHEMATIC

