

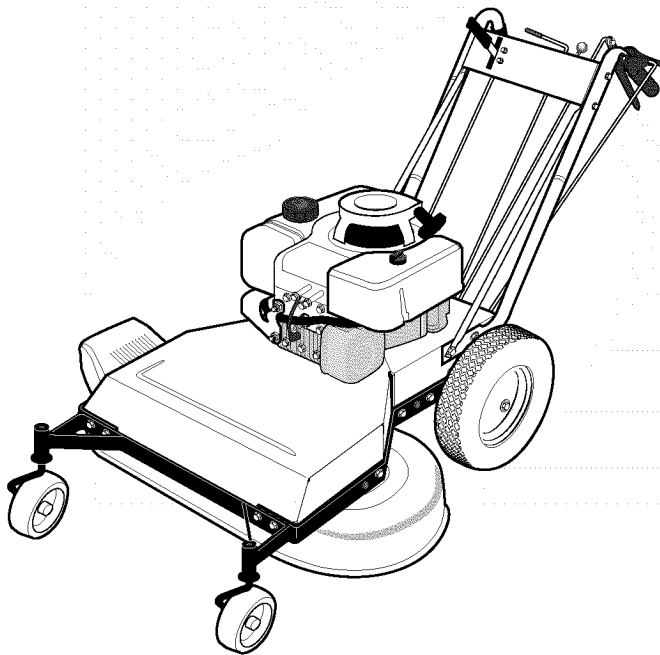

# Operator's Manual



Wide-Cut™ 33"  
Combination Mower  
Models 753B  
E753B

## **IMPORTANT: READ SAFETY RULES AND INSTRUCTIONS CAREFULLY**

**Warning:** This unit is equipped with an internal combustion engine and should not be used on or near any unimproved forest-covered, brush-covered or grass-covered land unless the engine's exhaust system is equipped with a spark arrester meeting applicable local or state laws (if any). If a spark arrester is used, it should be maintained in effective working order by the operator. In the State of California the above is required by law (Section 4442 of the California Public Resources Code). Other states may have similar laws. Federal laws apply on federal lands. A spark arrester for the muffler is available by contacting the service department at Troy-Bilt LLC, P.O. Box 361131 Cleveland, Ohio 44136-0019.

**TROY-BILT LLC, P.O. BOX 361131, CLEVELAND, OH 44136-0019**

PRINTED IN USA

FORM NO. 770-10602A  
(01/2002)

## **TABLE OF CONTENTS**

<b>Content</b>	<b>Page</b>
Safety .....	1
Assembly .....	4
Features and Controls .....	9
Operation .....	12
Maintenance .....	17
Lubrications .....	25
Off-Season Storage .....	25
Troubleshooting .....	28
Parts List .....	29
Warranty Information .....	Back Cover

## **FINDING MODEL NUMBER**

This Operator's Manual is an important part of your new Wide-Cut™ mower. It will help you assemble, prepare and maintain the unit for best performance. Please read and understand what it says.

Before you start assembling your new equipment, please locate the model plate on the equipment and copy the information from it in the space provided below. This information is very important if you need help from our Customer Support Department or an authorized dealer.

- You can locate the model number by looking at the rear surface of the tine shield. A sample model plate is explained below. For future reference, please copy the model number and the serial number of the equipment in the space below

 <p><b>TROY-BILT</b> LLC P. O. BOX 361131 CLEVELAND, OH 44136 330-558-7220 866-840-6483</p>	Copy Model Number Here _____
	Copy Serial Number Here _____

## **ENGINE INFORMATION**

The engine manufacturer is responsible for all engine-related issues with regards to performance, power-rating, specifications, warranty and service. Please refer to the engine manufacturer's Owner's/Operator's Manual packed separately with your unit for more information.

## **CALLING CUSTOMER SUPPORT**

If you have difficulty assembling this product or have any questions regarding the controls, operation or maintenance of this unit, please call the Customer Support Department.



Call **1- (330) 558-7220** or **1- (866) 840-6483** to reach a Customer Support representative. Please have your unit's model number and serial number ready when you call. See previous section to locate this information. You will be asked to enter the serial number in order to process your call .

**For more details about your unit, visit our website at [www.troybilt.com](http://www.troybilt.com)**

# Safety

## WARNING:

The engine exhaust from this product contains chemicals known to the State of California to cause cancer, birth defects, or other reproductive harm.

### Safety Alert Symbol



This is a safety alert symbol. It is used in this Owner's Manual to alert you to potential hazards. Whenever you see this symbol, read and obey the safety message that follows it. Failure to obey the safety message could result in personal injury or property damage.

## IMPORTANT

### Safe Operation Practices for Walk-Behind Mowers

This cutting machine is capable of amputating hands and feet and throwing objects. Failure to observe the following safety instructions could result in serious injury or death.

## I. GENERAL OPERATION

1. Read, understand, and follow all instructions on the machine and in the manuals. Be thoroughly familiar with the controls and the proper use of the mower before starting.
2. Do not put hands or feet near or under rotating parts. Keep clear of the mower blade and discharge opening at all times.



3. Only allow responsible individuals, who are familiar with the instructions, to operate the mower.
4. Clear the area of objects such as rocks, toys, wire, bones, sticks, etc., which could be picked up and thrown by the blade.



5. Be sure the area is clear of other people before mowing. Stop mower if anyone enters the area. Keep bystanders at least 25 feet away from the area of operation.
6. Do not operate the mower when barefoot or wearing open sandals. Always wear substantial foot wear.
7. Do not pull mower backwards unless absolutely necessary. Look down and behind before and while moving backwards.
8. Do not operate the mower without proper guards, plates, grass catcher or other safety protective devices in place.
9. Refer to provided instructions for proper operation and installation of accessories. Only use accessories approved by Garden Way Incorporated.
10. Stop the blade when crossing gravel drives, walks, or roads.
11. Stop the engine and disconnect the spark plug wire from the spark plug

whenever you leave the unit, before cleaning the mower or unclogging the chute.

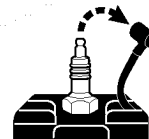

12. Shut the engine off, wait until the blade comes to a complete stop, and disconnect the spark plug wire before installing or removing the mulcher cover or the optional grass catcher. Make certain that the grass catcher is securely attached before operating the mower. Empty the grass catcher after each use—decomposing debris could generate enough heat to catch fire.
13. Mow in daylight or good artificial light.
14. Do not operate the mower while under the influence of alcohol or drugs.

## Section 1: Safety

15. Never operate mower in wet grass. Always be sure of your footing; keep a firm hold on the handle and walk; never run.
16. Disengage the Wheel Drive Lever on self-propelled models before starting the engine.
17. If the unit should start to vibrate abnormally, stop the engine and disconnect the spark plug wire. Then check immediately for the cause. Vibration is generally a warning of trouble.
18. Always wear safety goggles or safety glasses with side shields when operating mower.
19. Watch for traffic when operating near, or when crossing roadways.
20. Never attempt to carry children or other passengers on the mower. They could fall off and be seriously injured, or they could interfere with the safe operation of the mower.
21. Check the operation of the Operator Presence Control Bar before each use. See the Maintenance Section of this manual for instructions. If the engine runs longer than three seconds after the Operator Presence Control Bar is released, the system is not working properly. Immediately contact your local service dealer or the factory Technical Service Department for instructions. Do not use the mower until the mechanism is repaired.
22. The mower is equipped with a safety discharge chute, comes with special mulcher covers, and offers an optional grass catcher. The safety discharge chute must be working properly at all times. Never attempt to disconnect or otherwise cause this discharge chute to cease working. If used, mulcher cover or grass catcher attachment must be installed properly and function correctly. Do not use your equipment otherwise.
23. Never run the engine in an enclosed area. Engine exhaust contains carbon monoxide, a deadly gas that is odorless, colorless, and tasteless. Always run the engine outdoors and make sure there is adequate ventilation.

## II. SLOPE OPERATION

**Slopes are a major factor related to slip and fall accidents which can result in severe injury. All slopes require extra caution. If you feel uneasy on a slope, do not mow it.**



### DO:

Mow across the face of slopes; never up and down. Exercise extreme caution when changing direction on slopes. Avoid slopes greater than 15°.

Remove objects such as rocks, tree limbs, etc.

Watch for holes, ruts, or bumps. Tall grass can hide obstacles.

### DO NOT:

*Do not* mow near drop-offs, ditches, or embankments. The operator could lose footing or balance.

*Do not* mow excessively steep slopes.

*Do not* mow on wet grass. Reduced footing could cause slipping.

## III. CHILDREN

**Tragic accidents can occur if the operator is not alert to the presence of children. Children are often attracted to the mower and to the mowing activity. Never assume that children will remain where you last saw them.**

1. Keep children out of the mowing area and under the watchful care of a responsible adult.
2. Be alert and turn mower off if children enter the area.
3. Before and while moving backwards, look behind and *down* for small children.
4. Never allow children to operate the mower.
5. Use extra care when approaching blind corners, shrubs, trees, or other objects that may obscure vision.

## IV. SERVICE

1. Use extra care in handling gasoline and other fuels. They are flammable and their vapors are explosive.
  - a) Use only an approved container.
  - b) Never remove gas cap or add fuel when the engine is running. Allow engine to cool before refueling. Do not smoke.
  - c) Never refuel the machine indoors.
  - d) Never store the machine or fuel container inside where there is an open flame, such as a water heater, etc.
  - e) Move mower away from any gasoline fumes before starting the engine.
2. Never run an engine inside a closed area.
3. Never make adjustments or repairs with the engine running. Disconnect the spark plug wire and keep the wire away from the plug to prevent accidental starting.
4. Keep all nuts and bolts, especially the blade attachment bolts, tight and keep equipment in good condition.
5. Never tamper with safety devices. Check their operation regularly.
6. Keep mower free of grass, leaves or other debris build-up. Clean up oil or fuel spillage. Allow mower to cool before storing.
7. After striking an object, stop the engine and disconnect the spark plug wire. Inspect the mower and repair, if necessary, before restarting.
8. Never attempt to make mower cutting height adjustments while the engine is running.
9. Grass catcher components are subject to wear, damage and deterioration, which could expose moving parts or allow objects to be thrown. Frequently check components and replace with factory recommended parts, when necessary.

# Section 1: Safety



10. Mower blades are sharp and can cut. Wrap the blade or wear gloves, and use extra caution when servicing them.
11. Do not change the engine governor setting or overspeed the engine.
12. Do not touch engine parts which may be hot from operation. Allow parts to cool completely before inspecting, cleaning or repairing the mower.
13. To access the underside of the mower, tip the mower rearward. Do not tip the mower forward or on either of its sides, unless specifically advised to do so in this manual.
14. Maintain or replace safety and instructional decals. Refer to the separate Parts Catalog for replacement decal information.
15. For units equipped with electric start:
  - a) Batteries produce explosive gases. Keep sparks, flame, cigarettes, etc., away. Ventilate the area when charging the battery. Do not charge the battery in an airtight space.
  - b) Do not use a battery charger other than the one provided with the mower.
  - c) The battery contains toxic materials. Do not damage the battery case. If the case is broken or damaged, avoid contact with the battery contents.
  - d) Properly dispose of a damaged or worn out battery. Check with local authorities for proper disposal methods.
  - e) Do not short circuit the battery. Severe burns and fire can result.

## SAFETY DECALS

Make certain all safety decals on this equipment are kept clean and in good condition. The decals are shown (at reduced sizes) below. If you need a replacement decal, please refer to the Parts Catalog that accompanied this Manual.



On top, rear of engine platform

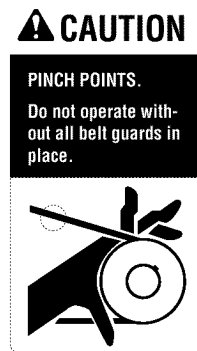

Beneath belt/pulley cover

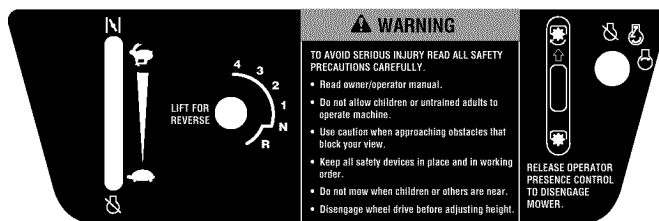

On Control Panel (for electric start model)

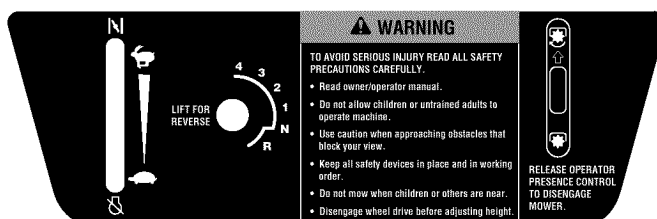

On Control Panel (for recoil start model)



On left side of mower deck

## ⚠ WARNING

To prevent personal injury or property damage, do not attempt to start the engine until all assembly steps are complete and you have read and understand the safety, controls and operating instructions in this manual.

## INTRODUCTION

Please carefully follow these assembly steps to properly prepare your machine for use. We recommend that you read this Section in its entirety before beginning assembly.

NOTE: All references to left, right, front and rear of the machine are determined by standing behind the handlebars and facing the direction of forward travel.

## INSPECTION AFTER DELIVERY

Inspect the shipping crate and machine immediately after delivery. Make sure neither the carton nor the contents have been damaged.

If you find or suspect any damage, contact the carrier (trucking company) immediately. Inform them of the specific damage and that you wish to file a claim. To protect your rights, be sure to put this in writing to the carrier within 15 days. The carrier will let you know how to proceed with your claim. Please let us know if you need any assistance.

## TOOLS/MATERIALS NEEDED:

- Wire Cutter
- 7/16" Wrench
- 3/8" Wrench
- Two 1/2" Wrenches
- Scissors or Pen Knife
- Needle-nose Pliers
- Motor Oil (see Step 5)
- Tire Gauge

## ASSEMBLY STEPS

**IMPORTANT:** MOTOR OIL MUST BE ADDED TO THE ENGINE BEFORE IT IS STARTED. FOLLOW INSTRUCTIONS IN THIS "ASSEMBLY" SECTION.

### STEP 1: Unpacking Mower

NOTE: LEFT and RIGHT sides of the unit are as viewed from the operator's position behind the handlebars.

1. Cut metal straps, if present, securing unit to pallet. Leave unit on pallet during assembly (to safely remove unit from pallet, wait until you have completed assembly steps 1-4).
2. Remove any protective packaging from around the handlebars. Cut the plastic tie straps holding the four long control rods to the handlebars. Do not remove the two long handlebar struts that are attached to the top of the handlebars.

### STEP 2: Attach Handlebars to Engine Deck

1. Remove the plastic ties holding the wheel drive rod (F, Figure 2-7) to the left handlebar and the blade drive rod (C, Figure 2-7) to the right handlebar. Put the rods aside.

NOTE: Four screws (D, Figure 2-2) are used to connect the handlebars to the engine deck. At the factory, these screws are threaded into lock nuts welded to the back sides of the deck.

2. Remove and save the four 5/16"-18 x 3/4" screws mentioned in the NOTE above.
3. From the front of the unit, tilt the right-side handlebar up over the air cleaner cover and lift the other handlebar upward. Rotate the handlebars over the engine and position the handlebar ends (E, Figure 2-2) against the sides of the engine deck.

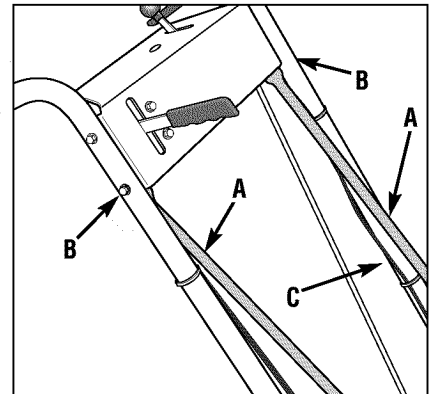

Figure 2-1

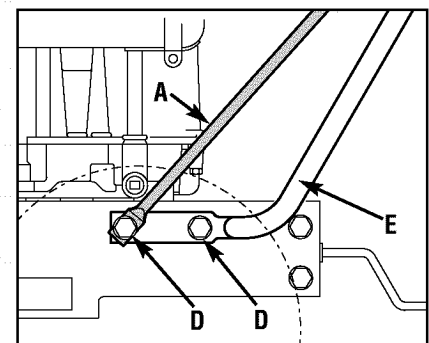

Figure 2-2: Attach handlebars and struts to engine deck.

4. Swing the handlebar struts (A, Figure 2-2) forward and align the handlebar ends (E, Figure 2-2) with the holes in the engine deck. Loosely install two 5/16"-18 x 3/4" hex flange screws removed earlier (D) into the rear holes.
5. Align the loose ends of the handlebar struts (A, Figure 2-2) over the front holes in the handlebar ends. Attach the struts and handlebars with two more 5/16"-18 x 3/4" hex flange screws. Securely tighten all four screws.
6. Securely tighten the screws (B, Figure 2-1) at the upper ends of the struts.

### STEP 3: Electric Start Model

#### A. Secure Wire Harness

1. At the unattached end of the electrical wire harness, there are four wires attached to a large plastic connector and two wires attached to a small plastic connector.

2. Plug the large connector into the bottom of the ignition keyswitch that is located on the underside of the handlebar console (not pictured).

3. Use two cable ties to secure the wire harness to the right handlebar and away from any moving parts. Place the ties an equal distance apart.

### B. Attach Wire Leads to Battery

1. The battery is located at the rear, right-side of the engine deck.

2. At the lower end of the electrical wiring harness, locate a red wire lead and a black wire lead.

- Plug terminal on red (positive) wire into red terminal (U, Figure 2-3) on battery.
- Plug terminal on black (negative) wire into black terminal (V).

3. If applicable, attach wire harness to engine deck using J-clips (W, Figure 2-4) as shown. Bend J-clips over to secure.

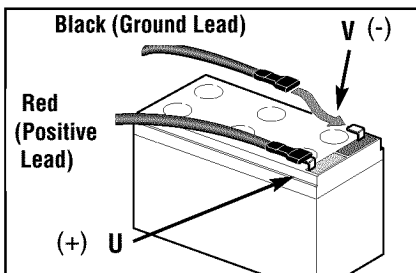

Figure 2-3: Connect wire terminals to battery terminals.

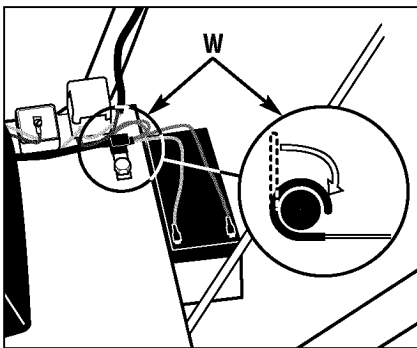

Figure 2-4: Attach wire harness with J-clips.

### ⚠ WARNING

Charge battery only with charger supplied with machine. Do not short circuit battery wires. Remove any jewelry before working on or near the battery or electric start system.

Failure to follow these instructions could result in personal injury or property damage.

### C. Charge the Battery

Charge a new battery for 24-48 hours to ensure a full charge. If the mower must be used immediately, the battery may have enough of a charge to start the engine. If not, the engine can be started with the rope pull starter. NOTE: Charge the battery after the initial use of the mower to help ensure it is fully charged.

### ⚠ CAUTION

If battery is removed, do not operate engine without insulating positive (+) battery cable terminal with electrical tape or sparking from battery cells can result.

1. To charge the battery, locate the plastic connector (T, Figure 2-5) that hangs from the wire harness below the handlebar console.

2. Plug the connector on the battery charger (Z, Figure 2-5) into the connector on the wire harness (T).

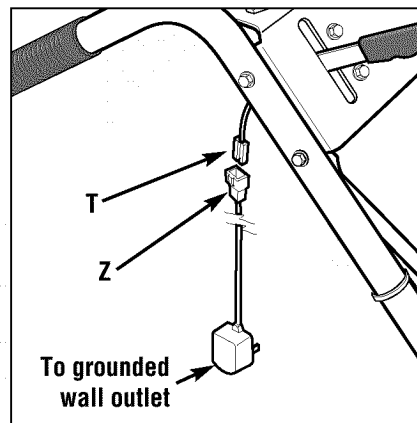

Figure 2-5

### ⚠ WARNING

Control rods are adjusted at the factory and should not require additional adjustment during assembly. After assembling unit, control rod adjustment should be checked (and re-adjusted, if necessary) according to information in Maintenance Section.

Failure to follow this instruction could result in severe personal injury or property damage.

3. Plug the battery charger into a 120V grounded wall outlet. NOTE: The battery charger is designed for use indoors and should not be exposed to rain or snow.

4. Charge battery for 24-48 hours.

5. After charging, unplug battery charger from wall outlet, then unplug charger from wire harness.

### STEP 4: Attach Control Rods

#### A. Attach Wheel Drive Control Rod

1. Locate the wheel drive control rod (F, Figures 2-6 & 2-7) that was removed from the left handlebar in Step 2. This rod has a swivel block (H, Figure 2-6) on one end.

2. At left side of engine deck, insert swivel block (H, Figures 2-6 & 2-7) on wheel drive control rod into wheel drive control arm (U, Figure 2-6).

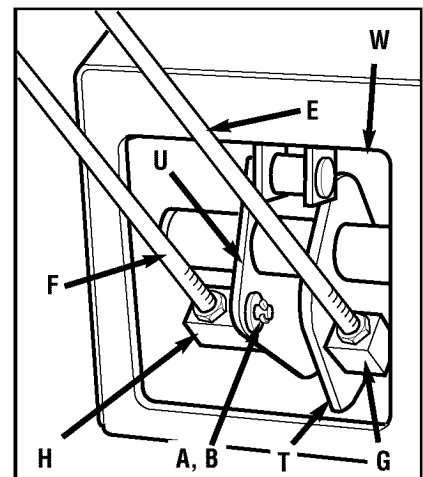
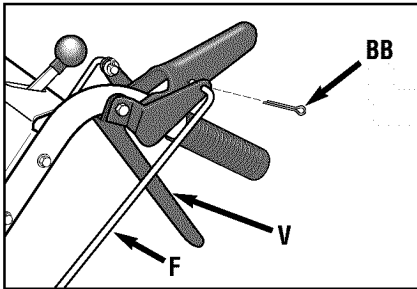

Figure 2-6: Left-hand control rods detail.

## Section 2: Assembly



**Figure 2-6A: Attach wheel drive control rod to lever.**

3. Add a 5/16" washer (A, Figure 2-6) and attach with a hairpin clip (B).

4. At upper end of control rod, insert angled end into Wheel Drive Control lever (V, Figure 2-6A) and attach with a cotter pin (BB). Bend ends of cotter pin over rod to secure.

### B. Attach Operator Presence Control Rod

1. Locate control rod (E, Figures 2-6 and 2-7) attached at upper end to Operator Presence Control lever (W, Figure 2-7).

2. At bottom of control rod, insert swivel block (G, Figures 2-6 & 2-7) into control arm (T, Figure 2-6).

3. Add one 5/16" washer and attach with cotter pin. Bend ends of cotter pin to secure.

### C. Attach Blade Drive Control Rod

1. Locate the blade drive control rod (C, Figure 2-7) that you removed in Step 2. Insert one end of control rod into blade drive bracket (D, Figure 2-7). Add one 5/16" washer and attach with hairpin clip (CC).

2. Insert upper end of rod into bottom end of Blade Drive Control lever (J, Figure 2-7). Add one 5/16" washer and attach with cotter pin (AA). Bend ends of cotter pin to secure.

### D. Attach and Adjust Gear Select Lever

**NOTE:** The retaining plate (N, Figure 2-7) mentioned in the following steps is secured to the rear of the mower with two screws (O, Figure 2-7) and 1/4"-20 lock-nuts. Remove the retaining plate and save it, along with the two screws, before proceeding with assembly.

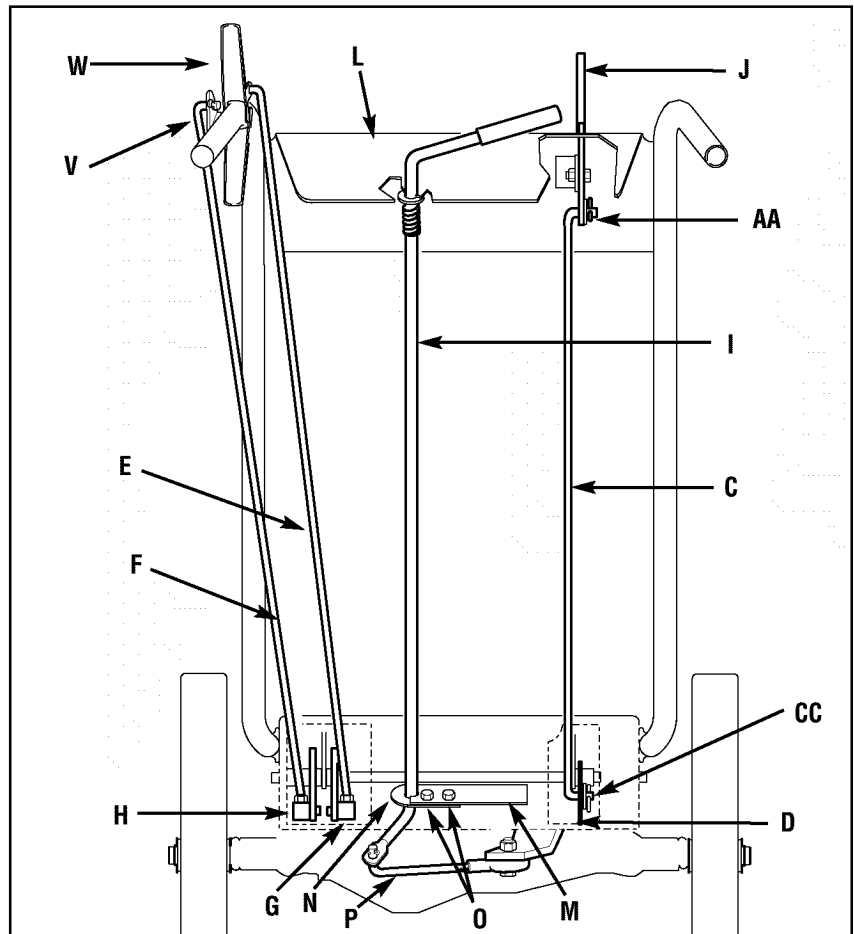

**Figure 2-7: Rear view of control rods.**

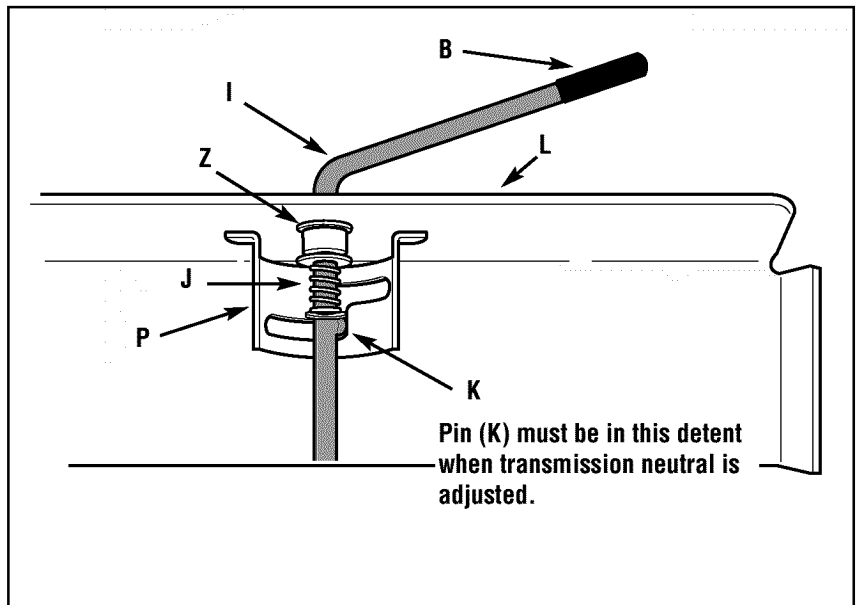

**Figure 2-8: Detail - Gear Select Lever in Neutral (N) position.**



1. Hold lower part of gear select lever (I, Figure 2-9) against bracket (M). Position retaining plate (N), removed earlier, as shown in Figure 2-9 (plate below bracket). Secure plate with two 1/4"-20 x 1/2" screws (O) and 1/4"-20 locknuts.
6. Slide grip (B, Figure 2-8) back onto gear select lever (I).
7. Rotate gear select lever (I, Figures 2-8 & 2-9) clockwise until spur (K - short rod) on gear select rod stops in the neutral position detent on the shift pattern quadrant (Figure 2-8).

8. At bottom of control rod, thread shift link (P, Figure 2-9) partially into ball-joint (Y).
9. Move shift arm (X, Figure 2-9) from side to side as necessary into each transmission gear detent until transmission is in neutral.

NOTE: Moving shift arm (X) all the way to the left, and then one notch back to the right, should put transmission into neutral. When transmission is in neutral, unit will move freely when pushed while holding the Operator Presence Control lever (W, Figure 2-7) down. If transmission is NOT in neutral, there will be a slight drag on the wheels when pushing unit.

10. When shift arm (X) is in neutral position, rotate shift link (P) toward end of gear select lever rod (I). Adjust length of shift link (P) as necessary to fit into hole in bottom of gear select lever (I).

NOTE: Pin (K) on Gear Select Lever (I) must be held in the neutral position detent on the shift quadrant (see Figure 2-8) while shift link (P, Figure 2-9) is adjusted.

11. Insert hooked end of shift link (P, Figure 2-9) into hole in bottom end of gear select lever (I) and secure with cotter pin (Q). Bend ends of cotter pin. NOTE: It may be necessary to lift gear select lever (I) to install shift link (P).

12. Remove unit from shipping crate. To remove, hold down Operator Presence Control lever (W, Figure 2-7) which releases the wheel brake.

13. With unit on level ground, hold down Operator Presence Control lever

(W, Figure 2-7) and push unit forward and backward. The wheels should move freely. If not, adjust length of shift link (P, Figure 2-9) as necessary.

14. Put the Gear Select Lever in neutral (N), release all of the control levers and try to push the unit forward and backward. The wheels should not turn. If they do turn, an adjustment is necessary. DO NOT OPERATE THE UNIT UNTIL THE WHEEL BRAKE MECHANISM HAS BEEN ADJUSTED AND IS WORKING PROPERLY. See "Wheel Brake Adjustment" in Section 5 "Maintenance."

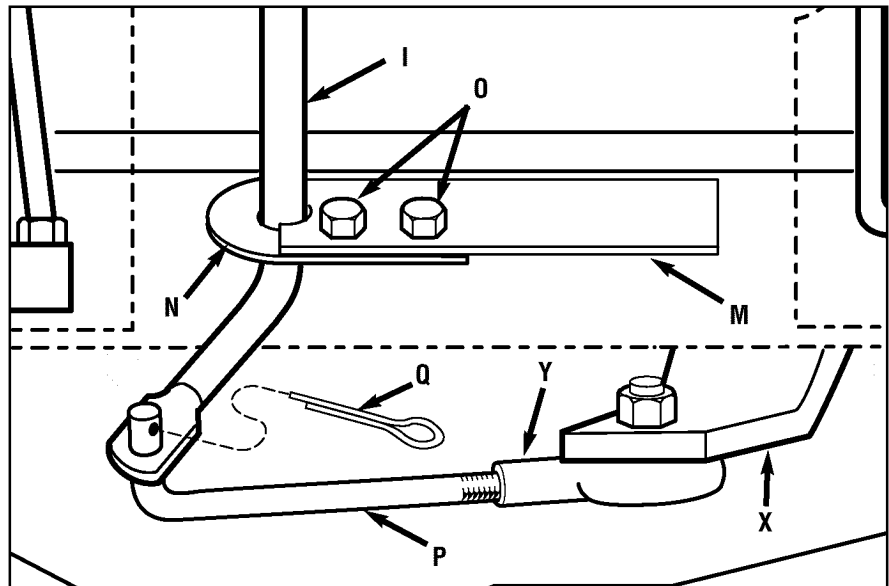

Figure 2-9: Detail - Transmission Neutral Adjustment.

### CAUTION

Unit is shipped without oil in engine crankcase. Do not start engine until oil has been added. Severe engine damage will result if this instruction is not followed.

#### STEP 5: Add Motor Oil to Engine

1. Move mower to a level area. Press and hold Operator Presence Control lever (W, Figure 2-7) to move mower.
2. Add motor oil according to the specifications and instructions provided in the separate Engine Owner's Manual that was included in the unit's literature package.
  - Keep oil level at the FULL mark on the dipstick to avoid engine damage.
  - Change oil according to schedule and instructions in Section 5 "Maintenance."

### WARNING

Do not use the mower if the wheels continue to turn after releasing the Operator Presence Control and the Wheel Drive Control.

Severe personal injury or property damage could result if this instruction is not followed.

#### STEP 6: Check Tire Pressure

1. Use a tire gauge to check the air pressure in the rear tires. The air pressure should be between 15-20 PSI (20 PSI maximum).
2. Keep both tires equally inflated to help prevent machine from pulling to one side.

#### STEP 7: After Assembling and Before Using Unit

1. Read this entire Owner's Manual for proper safety, operation and maintenance information.
2. Make sure spark plug wire is connected to spark plug before starting unit.

# Features and Controls

**IMPORTANT:** THE MOWER IS

## **⚠ WARNING**

Before operating mower, be sure to read all safety, controls and operating instructions in this Manual and on decals located on machine.

Severe personal injury or property damage could result if this instruction is not followed.

EQUIPPED WITH A BLADE-BRAKE-CLUTCH CONTROL SYSTEM WHICH IS DESIGNED TO STOP THE MOWER BLADES WITHIN THREE (3) SECONDS AFTER RELEASE OF THE OPERATOR PRESENCE CONTROL. THIS SYSTEM WILL STOP THE BLADES BUT NOT THE ENGINE. THEREFORE, YOU CAN DISENGAGE THE BLADE DRIVE AT ANYTIME WITHOUT HAVING TO STOP AND RESTART THE ENGINE. THIS FEATURE IS PARTICULARLY USEFUL WHEN YOU NEED TO CROSS GRAVEL DRIVES OR ROUGH TERRAIN AND YOU DO NOT WANT THE SPINNING BLADES TO STRIKE STONES OR HIDDEN OBSTACLES.

## **⚠ WARNING**

The blade-brake-clutch control system should stop the mower blades within three (3) seconds after release of the Operator Presence Control.

If the blades do not stop within three (3) seconds, put the Engine Throttle Control in the STOP position. Disconnect the spark plug wire and do not operate the mower until the blade-brake-clutch control system has been repaired.

## MOWER FEATURES AND CONTROLS

This section describes the various features and controls on the unit. Refer to the next section "Operation" for detailed operating instructions. Also, read the separate Engine Owner's Manual for a detailed explanation of the proper use of the engine controls.

### Operator Presence Control

The Operator Presence Control lever (A, Figure 3-1) regulates the operation of the rear wheel brake and the separate Blade Drive Control. Always engage this control before engaging the separate blade drive or wheel drive controls. Always disengage this control before starting the engine.

To engage the Operator Presence Control, press and hold the lever against the handlebar grip. Doing so releases the brake on the rear wheels, allowing the wheels to turn. The engaged position also permits the separate Blade Drive Control to lock in its engaged position (allows the mower blades to turn).

Releasing the lever (disengaged position) applies the rear wheel brake and quickly stops the wheels. Releasing

the lever will also disengage the Blade Drive Control, which will apply a brake that stops the blades within three (3) seconds.

### Blade Drive Control

Use this lever (B, Figure 3-1) to engage drive to the mower blades.

To engage the blades, first engage the Operator Presence Control (A, Figure 3-1). Then, push the spring-loaded Blade Drive Control lever (B) forward until it stays in the engaged position.

To stop the blades, release the Operator Presence Control (A). Doing so will disengage the Blade Drive Control (B) and automatically apply the brake that stops the blades.

Always disengage the Blade Drive Control before starting the engine. This helps to ensure that the blades will not start turning when the engine starts.

**NOTE:** Pushing the Blade Drive Control forward will engage the blades even though the Operator Presence Control is not engaged. However, this procedure is **NOT RECOMMENDED** as you must maintain constant pressure on the lever (releasing lever disengages blades). Always engage the Operator Presence Control before engaging the Blade Drive Control.

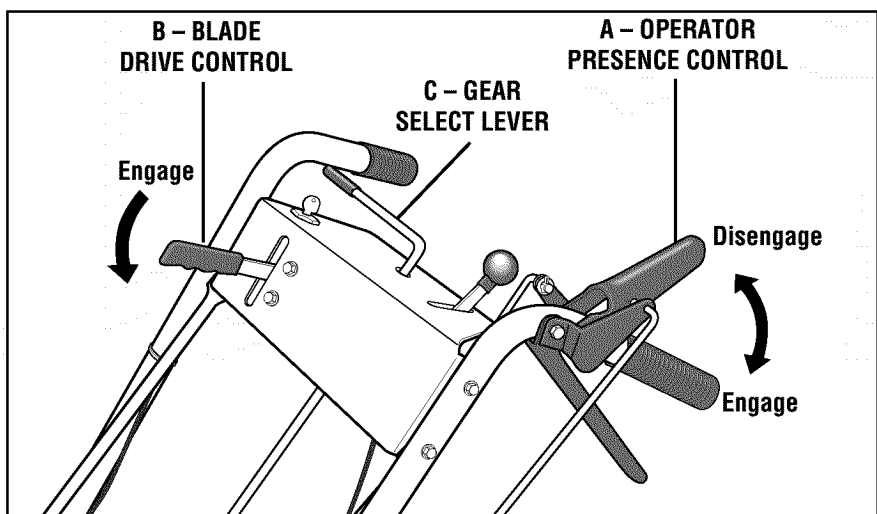

Figure 3-1

## Section 3: Features and Controls

**Operating Symbols** Various symbols are used on the mower to indicate control settings (your model may not have all of the symbols). These symbols are shown below with a description of their meaning.



FAST



SLOW



CHOKE



ENGAGE



DISENGAGE



ENGINE STOP



ENGINE START



ENGINE RUN

### Gear Select Lever

Use this lever (C, Figure 3-1) to select any of four forward ground speeds (1 - Slow, 2 and 3 - Medium, 4 - Fast), N (Neutral) and R (Reverse). The gear shift pattern is shown in Figure 3-2.

**To avoid damaging the transmission, do not shift gears when the mower is moving.**

For forward travel, use one of the four numbered settings. To select reverse, shift to neutral and then pull up on the lever. Turn the lever to the R (reverse) position and release the lever.

Put the lever in N (neutral) to manually push the mower and when the mower is not in use.

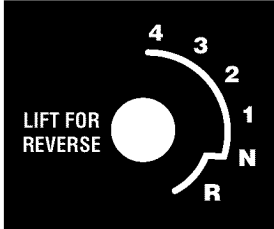

Figure 3-2:  
Shift pattern  
on console.

Presence Control along with the Wheel Drive Control.

When starting the engine, the Wheel Drive Control should be disengaged (released). This helps to ensure that the wheels will not start turning when the engine starts.

### CAUTION

**Do not engage the Wheel Drive Control without first engaging the Operator Presence Control. Doing so could result in wear or damage to the wheel brake mechanism.**

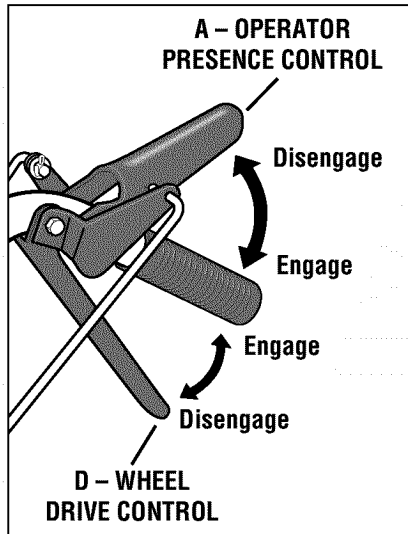

Figure 3-3

### Cutting Height Control Lever

Use this lever (E, Figure 3-4) to adjust the cutting height from 1 to 4 inches. Note that actual cutting heights will vary according to soil conditions.

Turn the lever clockwise to raise the height or counterclockwise to lower the height. A decal and pointer (not illus-

trated) on the right side of the mower deck show the cutting height settings ranging from A (highest) to G (lowest).

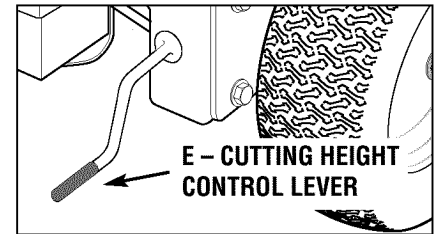

Figure 3-4

### Mulcher Cover

The mulcher cover (F, Figure 3-5) is pre-installed at the factory. It must be kept in place when using the unit as a mulching mower. The mulcher cover is designed to keep the discharge chute raised up while you mow. When the cover is removed for side-discharge mowing, the discharge chute lowers.

Refer to "4. Select Mulching or Side-Discharge Mowing" in the Operation Section for mulcher cover installation instructions.

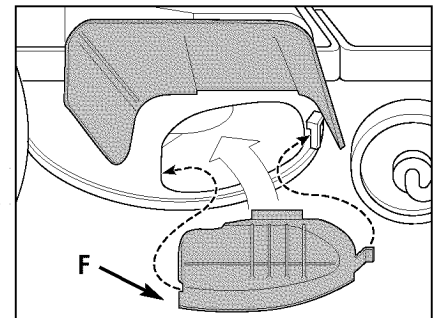

Figure 3-5

### Wheel Drive Control

Use this lever (D, Figure 3-3) to engage and disengage drive to the wheels.

To engage the wheels, first select a forward or reverse gear with the Gear Select Lever and squeeze the Operator Presence Control (A, Figure 3-3). Then, squeeze the Wheel Drive Control lever (D) against the handlebar grip. The ground speed can be varied by increasing or decreasing pressure on the lever. **To avoid sudden acceleration, slowly squeeze the lever when first engaging the wheels.**

Release the Wheel Drive Control to disengage the wheels. The wheels will gradually slow to a stop. **NOTE:** To stop the wheels quickly, release the Operator

## Section 3: Features and Controls

### Engine Throttle Control

This lever (G, Figure 3-6) is used to adjust engine speeds and to stop the engine. Always run engine at fast speed setting for best mower performance. The throttle settings are shown below.



**CHOKE** - Use when starting a cold engine.



**FAST** - Use during mower operation.



**SLOW** - Use when idling engine.



**STOP** - Stops engine.

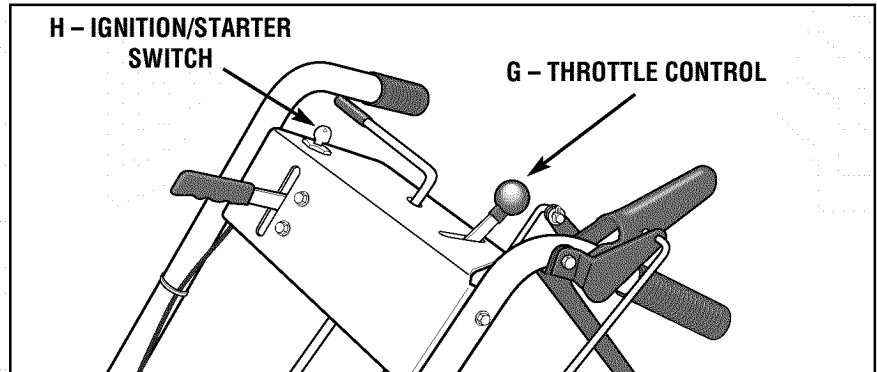

Figure 3-6

### Ignition/Starter Switch - (Electric Start Model)

This three-position switch (H, Figure 3-6) is used to start and stop the engine on electric start models. The ignition key settings are shown below. Do not turn the key until you have read the Operation Section in this Manual.

Always remove ignition key when leaving mower unattended or when inspecting, cleaning or servicing mower.



**STOP** - Stops engine.



**RUN** - After starting, key returns to run position.



**START** - Starts engine. Release key when engine starts.

### Engine Recoil Starter

The recoil starter (I, Figure 3-7) is used to “pull-start” the engine. Detailed instructions for using the recoil starter are found in the Operation Section of this Manual and in the Engine Owner's Manual. Do not pull the recoil starter until you have read the Operation Section.

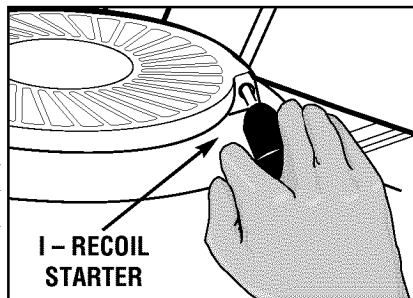

Figure 3-7

## WARNING

Before operating mower, be sure to read all safety, controls and operating instructions in this Manual and on decals located on machine.

Severe personal injury or property damage could result if this instruction is not followed.

### BEFORE OPERATING MOWER

#### 1. Pre-Operation Checklist

With the spark plug wire disconnected from the spark plug, perform the following checks and services before each use:

1. Review Section 1: "Safety" and Section 3, "Features and Controls" in this manual. Read the separate Engine Owner's Manual provided with the unit.
2. Check unit for loose or missing hardware. Tighten or replace as needed.
3. With the unit on level ground, check the engine oil level according to the instructions in the Engine Owner's Manual. The oil level should be at the FULL mark on the dipstick or up to the top of the oil fill hole on engines without a dipstick.
4. Check all levers for freedom of movement. Readjust or repair as needed before starting engine.
5. Check that all guards and shields are in place and properly secured.
6. Inspect the area to mowed and remove any debris which could be picked up and thrown by the mower blades.
7. Check that the mulcher cover is properly installed in the discharge opening (see instructions in this Section). Remove the mulcher cover to use the side-discharge mowing feature.
8. On electric start models, check that all wiring connections are clean and tight.

9. Check the air pressure in the rear tires (15-20 PSI). Keep tires inflated equally.

## DANGER

**GASOLINE IS HIGHLY FLAMMABLE AND ITS VAPORS ARE EXPLOSIVE. To help prevent severe personal injury or property damage:**

- Follow gasoline safety rules in Section 1: "Safety" of this Manual and in the separate Engine Owner's Manual.

- Never remove the gasoline fill cap or add fuel when indoors or when engine is running or still hot. Allow engine to cool at least three (3) minutes before refueling.

- Keep smoking materials, sparks or flames far away from fuel tank and fuel container.

- Store gasoline in an approved fuel container and in a well-ventilated area. Store it safely out of the reach of children. Do not store gasoline where vapors can reach an open spark or flame or where ignition sources are present (such as hot water or space heaters, furnaces, clothes dryers, stoves, electric motors, etc.).

- Fill tank to 1/2" below bottom of filler neck to allow for fuel expansion. Wipe up spilled gasoline immediately and move mower away from gasoline fumes before starting engine. Securely replace caps on fuel tank and fuel container.

10. Remove the fuel cap and check the level of gasoline according to the instructions in the Engine Owner's Manual. Clean around fuel fill area before removing fuel cap. Do not check fuel level or add fuel while indoors or if engine is running or hot. Allow engine to cool for three (3) minutes. Fill the tank with fresh,

clean unleaded gasoline with a minimum octane rating of 77. Leave 1/2" of space for fuel expansion. Do not mix oil with gasoline. Do not use gasoline which contains Methanol. See the Engine Owner's Manual for instructions and precautions regarding the use of gasolines that are blended with alcohols or ethers (called oxygenated or reformulated gasolines). Securely replace caps on fuel tank and fuel container.

11. Attach spark plug wire to spark plug after completing above checklist.

#### 2. Set Mower Cutting Height

## CAUTION

To avoid personal injury, do not adjust cutting height while wheels or blades are turning. Release all handlebar controls and wait for all motion to stop before adjusting cutting height.

1. Release all controls before adjusting the cutting height.
2. Adjust the cutting height from 1 to 4 inches by rotating the Cutting Height Control lever (Figure 3-4) either clockwise to raise the height or counterclockwise to lower the height. Note that actual cutting heights will vary according to grass and soil conditions. A decal and pointer on the right side of the mower deck indicates the height setting.
3. In heavy or tall grass, it is usually better to make the first cut at a higher setting and then make a second cut at the desired height. In rough terrain, a higher setting is recommended as it will minimize the chances of the blade striking the ground or hidden obstructions.

## Section 4: Operation

### 3. Test Blade-Brake-Clutch Control System

The mower is equipped with a blade-brake-clutch which is designed to stop the mower blades within three (3) seconds after release of the Operator Presence Control or the Blade Drive Control. Never tamper with, or attempt to defeat the purpose of this safety device.

The control system is a mechanical device which is subject to wear. Therefore, test the operation of the blade-brake-clutch control system before each use of the mower. Refer to "Blade Brake Control Test" at the end of this Section.

### 4. Select Mulching or Side-Discharge Mowing

#### **⚠ WARNING**

**Before installing or removing mulching cover, stop engine, wait for parts to stop moving, and disconnect spark plug wire. Remove ignition key on electric start models.**

You can use the mower either as a mulching mower or as a side-discharge mower. To use the mulching feature, insert the mulcher cover as described below. Remove the mulcher cover to side-discharge grass clippings. The mulcher cover is designed to keep the discharge chute raised up while mowing. When the cover is removed, the discharge chute will lower itself for side-discharge mowing.

To install or remove mulcher cover:

1. Stop the engine and wait for all parts to stop moving. Disconnect the spark plug wire from the spark plug. Remove the ignition key on electric start models.
2. To install the cover, insert the right-side tab of the cover into the front support bracket (A, Figure 4-1). Insert the cover into the discharge opening, making sure that the slot (B) in the left side of the cover is completely engaged in the rear edge of the deck opening.

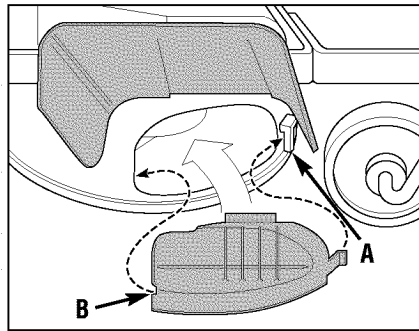

Figure 4-1: Mulcher cover

3. To remove the cover, slide the cover to the right (front of mower) to disengage the slot (B) from the mower deck and then pry the left-side of the cover out and off.

### MOVING THE MOWER WITHOUT ENGINE POWER

The mower can be manually pushed or pulled by putting the Gear Select Lever (C, Figure 4-2) in N (neutral) and pressing and holding the Operator Presence Control (A, Figure 4-2) down against the handlebar grip.

To stop the wheels at anytime, release the Operator Presence Control.

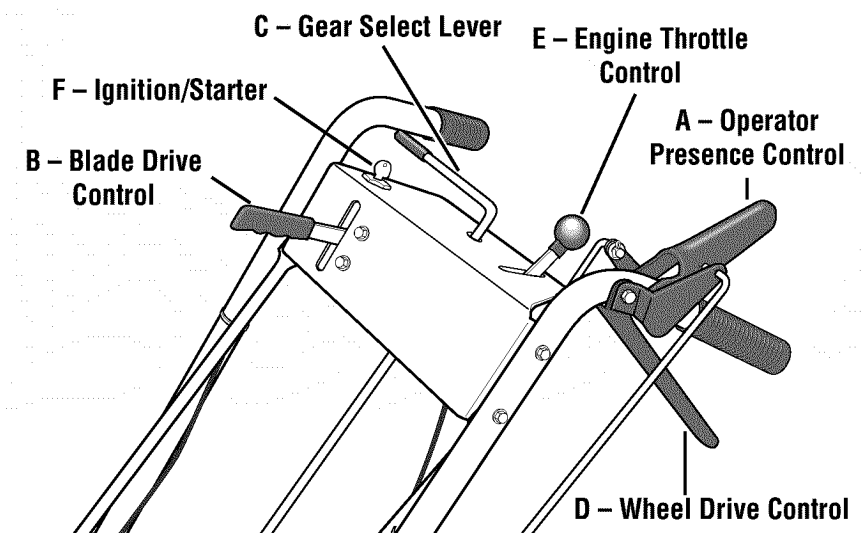

Figure 4-2: Mower Controls

### STARTING AND STOPPING THE ENGINE

#### **⚠ DANGER**

**Do not operate the engine in an enclosed area. Engine exhaust contains carbon monoxide, a deadly gas that is odorless, colorless and tasteless. Always run engine outdoors and make sure there is adequate ventilation.**

#### To Start the Engine

1. Move mower to a level area.
2. Release all controls on mower to prevent wheels or mower blades from rotating when engine starts.
3. Move Engine Throttle Control (E, Figure 4-2) fully upward to choke setting to start a cold engine or to fast (rabbit) setting to start a warm engine.

#### **⚠ WARNING**

To avoid injury:

- Keep hands and feet clear of mower blades or other rotating parts.
- Look behind you to be sure there are no obstacles before pulling recoil starter rope.

4. To start engine using recoil starter:
  - A. Stand on left side (as viewed from behind handlebars) of machine. Be sure your feet are safely away from the underside of the mower deck and all mower controls are released. Place one foot on top of tire.
  - B. Grasp starter rope handle (Figure 3-7) and pull slowly until rope pulls slightly harder. Let rope rewind slowly. Then pull rope with a rapid, full arm stroke. Let rope return slowly. If engine fails to start after three pulls, repeat instructions starting with Step 2 (try setting throttle at fast setting).
  - C. When engine starts, operate in fast throttle setting (move throttle from choke setting to fast setting).
5. To start engine using electric starter:
  - A. Stand behind the handlebars and release all mower controls.
  - B. Turn ignition key (F, Figure 4-2) fully clockwise to crank engine. To avoid damage to starter motor, do not crank engine for longer than five seconds at a time. Also, allow 15 seconds between each start attempt. If engine fails to start after three attempts, repeat instructions starting with Step 2 (try setting throttle at fast setting).
  - C. When engine starts, release key and it will return to the run (middle) position.
  - D. Operate engine at fast throttle setting (move throttle from choke setting to fast setting).

NOTE: If the electric start system is not functioning, the engine can be started with the recoil starter. To do so, first put the ignition key in the run (middle) position. Then follow Steps 1-4 above. Leave the key in the run position during engine operation.

### To Stop the Engine

1. Release all mower controls to stop wheels or mower blade.
2. Move throttle control down to slow (turtle) position. (Whenever possible, gradually reduce engine speed before stopping engine.)

3. Move Throttle Control all the way down to stop position or turn ignition key (electric start models) fully counter-clockwise to stop position.
4. On electric start models, remove the ignition key before leaving the mower unattended.

### ENGAGING THE BLADES

#### DANGER

To avoid injury from rotating blades, keep face, hands and feet clear of mower blades at all times.

### To Engage the Blades

1. Start engine as described in "To Start the Engine" instructions. Put engine throttle in fast speed setting.
2. Press and hold Operator Presence Control (A, Figure 4-2) against handlebar grip.
3. Slowly push Blade Drive Control (B, Figure 4-2) fully forward until it stays in the engaged position. The blades are now rotating.

### To Stop the Blades

To stop the blades, release the Operator Presence Control.

### TO ENGAGE THE WHEELS

#### CAUTION

- To avoid damaging the transmission, do not shift gears while in motion.
- To avoid damaging the wheel brake mechanism, do not engage the Wheel Drive Control without first engaging the Operator Presence Control.

1. Start engine as described in "To Start the Engine" instructions.
2. FOR FORWARD TRAVEL:
  - A. Press and hold Operator Presence Control (A, Figure 4-2) against handlebar grip.
  - B. Put the Gear Select Lever (C, Figure 4-2) into one of the numbered settings (1 - Slow, 2 and 3 - Medium, 4

- Fast). When first practicing with the mower, put lever in No. 1 setting. Select forward speeds according to mowing conditions and terrain. Use slower speeds on rough terrain or when grass is heavy or thick. The forward speed can be increased on smooth terrain or if the grass cover is light. Allow the wheels to stop completely before shifting from one forward speed into another.

#### WARNING

Before engaging the Wheel Drive Lever for the very first time, check that the neutral (N) position on the Gear Select Lever is properly adjusted. See "Neutral Adjustment" in Section 5: Maintenance for the procedure to follow.

Failure to follow this instruction could result in personal injury or property damage.

- C. To start the wheels, slowly squeeze the Wheel Drive Control (D, Figure 4-2). The harder you squeeze, the faster the wheels will turn. To avoid sudden acceleration, slowly squeeze the lever.
- D. TO STOP THE WHEELS:
  - To stop drive power to the wheels, release the Wheel Drive Control. The wheels will gradually slow to a stop.
  - To quickly stop the wheels, release **both** the Wheel Drive Control and the Operator Presence Control.

### 3. FOR REVERSE TRAVEL:

#### WARNING

To avoid injury or property damage:

- Look behind the mower before and during reverse operation.
- Stop the mower blades before operating in reverse.

- A. Stop the mower blades and wheels by releasing the Operator Presence Control (A, Figure 4-2).
- B. Press and hold Operator Presence Control against handlebar grip.

## Section 4: Operation

- C. Put the Gear Select Lever (C, Figure 4-2) in R (reverse) setting by first moving lever to N (neutral). Then pull lever up, turn it to R position, and release lever.
- D. To start the wheels, slowly squeeze Wheel Drive Control (D, Figure 4-2). To avoid sudden acceleration, slowly squeeze the lever.
- E. TO STOP THE WHEELS:
- To stop drive power to the wheels, release the Wheel Drive Control. The wheels will gradually slow to a stop.
  - To quickly stop the wheels, release **both** the Wheel Drive Control and the Operator Presence Control.
  - Return the Gear Select Lever to the N (neutral) position when you have completed reverse operation. Allow the wheels to stop completely before shifting from R (reverse) into a forward speed.

### MAKING TURNS



The mower turns easily by pushing the handlebars in the opposite direction that you want to turn. The differential mechanism inside the transaxle will allow the inside turning wheel to stop or slow down while the outside turning wheel is powered by the drive system.

Reduce the wheel speed before turning the mower. For tight turns, disengage the Wheel Drive Control and manually push the mower through the turn (if needed, put the Gear Select Lever in neutral so the wheels turn freely).

### MOWING TIPS AND HINTS

#### **⚠ WARNING**

To avoid injury or property damage:

- Before mowing, thoroughly inspect area where mower is to be used and remove all stones, sticks, wires, bones, nails and other foreign objects.
- Disengage mower blades before crossing gravel drives, roads, or sidewalks to prevent blades from throwing stones or other hazardous objects.

### Mow When Lawn Is Dry



For best results, avoid cutting grass when it is wet. Wet grass tends to form clumps which interfere with the cutting action. The best time to mow is in the late afternoon or early evening when the grass is usually dry.

### Cut Top 1/3 of Grass Blades



Cutting more than 1/3 of grass length may cause the grass to become excessively dry. In tall grass, it may be necessary to mow at a higher setting and then mow again at the desired height. NOTE: The cutting height is critical to achieving a well-groomed lawn. You should experiment with various settings to find that “just right” cutting height.

### Vary Cutting Pattern



Vary the cutting pattern from week to week to help prevent matting of the grass. One week, mow from north to south, the next week mow from east to west. Overlap several inches when mowing to obtain an even appearance.

### Mowing on Slopes



Do not mow excessively steep slopes (see WARNING statement that follows). Slow down and exercise extreme caution when changing direction on slopes. Before mowing on slopes, check the engine oil level and make sure that the level is at the FULL mark. Maintaining a FULL oil level is particularly important when operating on slopes as oil can be drained away from vital engine parts.

#### **⚠ WARNING**

To avoid injury or property damage:

- Maximum safe operating angle is 15°.
- Exceeding maximum safe operating angle may cause tipping or loss of footing.
- Do not mow wet slopes.
- Mow across slopes, not up and down.
- Exercise extreme caution when changing direction on slopes.

### Mulching Leaves

- The mower can be used to mow fallen leaves. The leaf particles filter down into the lawn and provide added fertilizer.
- The leaves must be dry in order to be mulched.
- Use a slower ground speed if the leaves are not mulched into fine particles.
- If you mulch oak leaves (which add acid to the soil), add lime to the lawn in the spring to reduce the acidity of the soil.

### Keep Mower Blades Sharp

For best mower performance, keep the blades sharp. Dull blades will tear, bruise and split the ends of grass. See blade sharpening instructions in Section 5: Maintenance.

### Clean Mower Frequently

Clean the underside of the mower deck frequently to remove grass build-up. See mower cleaning instructions in Section 5: Maintenance.

### Precision Trimming

For precision trimming, use the slowest gear and inch the mower along by “feathering” the Wheel Drive Control lever. Or, disengage the wheel drive by releasing the Wheel Drive Control so that you can manually maneuver the mower (if needed, put the Gear Select Lever in neutral so that the wheels turn freely).

### Mowing Ditches

If you have to mow ditches, stop the engine and adjust the cutting height to its highest setting. Mow in the direction of the ditch. Mow both sides of the ditch



first, and then mow the bottom. When mowing ditches, watch out for cans, bottles, or other debris.

### BLADE BRAKE CONTROL TEST

When the Operator Presence Control is released during operation of the mower, the engine does not stop, but the blades should stop within three (3) seconds. The following test provides a visual test of whether the Blade Brake Control System is functioning. Perform this test before each use of the mower.

#### WARNING

To avoid personal injury or property damage, make sure that the mower is on grass, and that the test area is clear of foreign objects and bystanders before you begin the Blade Brake Control Test.

If the Operator Presence Control or the Blade Drive Control are not adjusted correctly, the blades may continue to rotate after release of the Operator Presence Control. If the blades do not stop within three (3) seconds of release of the Operator Presence Control, move the Engine Throttle Control to the STOP position, disconnect the spark plug wire, and move the wire away from the spark plug. Do not operate the mower until the Blade Brake Control System has been repaired.

Failure to do this could result in personal injury or property damage.

1. Park mower on a portion of lawn which has not been recently mowed.
2. Set the cutting height so the mower cuts 1/3 of the grass height.
3. Start the engine.
4. Press the Operator Presence Control down against the handlebar grip and push the Blade Drive Control fully forward until it stays in the engaged position.
5. Put the Gear Select Lever in the No. 1 setting.
6. Engage the wheels with the Wheel Drive Control and drive the mower for several feet. Then release the Operator Presence Control.
  - A. Look at the lawn just mowed. The lawn should be cut up to the point where the Operator Presence Control was released.
  - B. Press the Operator Presence Control against the handlebar grip but DO NOT re-engage the Blade Drive Control. Drive the mower forward for several more feet. Release the Operator Presence Control and look at the lawn. The grass should NOT have been cut. This indicates that the Operator Presence Control has disengaged the blade drive and stopped the blades.
7. If the mower cuts the grass in Step 6-B, the Operator Presence Control is NOT disengaging the blade drive.

***Immediately stop the engine, disconnect the spark plug wire, and move the wire away from the spark plug.***

8. Do not use the mower until the Blade Brake Control System has been inspected, adjusted or repaired by an authorized dealer.

## WARNING



Before inspecting, cleaning or servicing the machine, shut off engine, wait for moving parts to stop, disconnect spark plug wire and move wire away from spark plug. Remove ignition key (electric start models). Failure to follow these instructions can result in serious personal injury or property damage.

Carefully read this Section on mower and engine maintenance and service. Performing the required maintenance according to schedule will ensure the proper performance and long life of your machine.

## WARNING

Before inspecting, cleaning or servicing the machine, shut off engine, make sure that all moving parts have come to a complete stop, disconnect spark plug wire and move wire away from spark plug. Remove ignition key on electric start models.

Failure to follow these instructions can result in personal injury or property damage.

NOTE: All references to left, right, front and rear of the machine are determined by standing behind the handlebars and facing the direction of forward travel.

**IMPORTANT:** REFER TO MAINTENANCE CHART IN THIS SECTION FOR A LISTING OF REGULARLY SCHEDULED MAINTENANCE PROCEDURES.

## ENGINE SERVICE

Routine engine service is described below. For more complete engine service information, refer to the engine manual provided with your machine. For complete engine service, contact an authorized engine dealer.

## ENGINE OIL

**OIL LEVEL:** With mower on level ground, the engine oil level must be between the "ADD" and "FULL" marks on the dipstick at all times. Check before each use and every 5 operating hours.

**OIL CHANGE:** On a new engine, change oil after first 2 hours of use, then change oil regularly as specified on the

Maintenance Chart. Refer to Engine Owner's Manual for oil capacity.

**OIL TYPE:** Use clean, high quality detergent oil having an A.P.I. service classification of SE, SF or SG. Use no special additives with oil. Refer to the Engine Owner's Manual for recommended SAE viscosity grades that match the starting temperature anticipated before the next oil change.

### Checking Oil Level:

1. Park machine on level ground.
2. Stop engine, wait for parts to stop moving, and disconnect spark plug wire.
3. Clean area around dipstick (Z, Figure 5-1) to prevent dirt from entering oil fill hole.
4. Remove dipstick. Oil level must be between "ADD" and "FULL" marks. Do not exceed "FULL" mark on dipstick.
5. To add oil, pour slowly into dipstick opening. While adding, check oil level frequently by securely replacing dipstick and removing to read oil level. Wipe dipstick clean each time oil level is checked.
6. After filling to "FULL" mark, securely replace dipstick.

### Changing Oil:

Change oil while engine is still warm from recent operation. Warm oil flows more freely and carries away more impurities.

1. Stop engine, wait for parts to stop moving, and disconnect spark plug wire.
2. Remove dipstick (Z, Figure 5-1).
3. Remove protective cap (A, Figure 5-2) to expose oil drain port (B).
4. Push oil drain hose (D) (included in hardware bag with unit) onto oil drain port. Route other end of hose to an appropriate oil collection receptacle.

5. Twist oil drain fixture (C) to the open position. Pull out. Drain oil completely.

6. Push in and twist oil drain fixture to the closed position. Remove drain hose. Replace protective cap (A).

7. Refill engine with fresh oil and securely replace dipstick.

NOTE: Please dispose of all waste materials in an ecologically responsible manner. Use proper waste material storage containers.

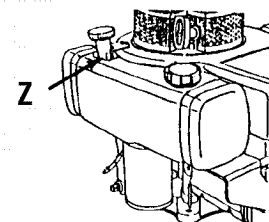

Figure 5-1: Briggs and Stratton engine oil fill.

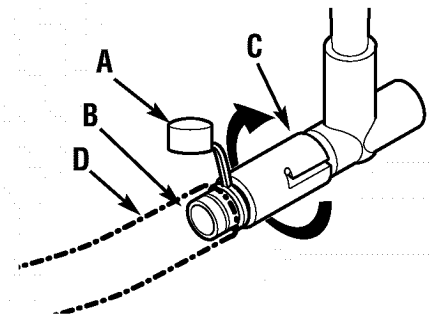

Figure 5-2: Oil drain.

### WARNING



Before inspecting, cleaning or servicing the machine, shut off engine, wait for moving parts to stop, disconnect spark plug wire and move wire away from spark plug. Remove ignition key (electric start models). Failure to follow these instructions can result in serious personal injury or property damage.

### ENGINE CLEANING

- Stop engine, wait for parts to stop moving, disconnect spark plug wire, and allow engine to cool before inspecting or cleaning engine.
- Daily or more often, before running engine, remove grass and chaff from recoil finger guard or rotating screen to prevent engine damage caused by overheating. Also keep cooling vanes, governor linkage, springs and controls free of debris.
- Daily or more often, before running engine, clean muffler area (be sure muffler is cool) to remove all grass and combustible debris. If engine is equipped with a spark arrestor screen, remove assembly every 50 hours for cleaning and inspection. Replace if damaged.
- Grass or chaff may clog engine's air cooling system, especially after prolonged operation cutting tall, dry grass. See Engine Owner's Manual for instructions on cleaning underneath the engine blower housing.

### AIR CLEANER SERVICE

Improper air cleaner maintenance can cause engine damage. Refer to the Engine Owner's Manual for more complete air cleaner service information.

#### SERVICE SCHEDULE:

Outer foam pre-cleaner - wash and re-oil every 25 operating hours or every season, whichever occurs first.

Inner paper cartridge - clean or replace every 100 operating hours or every season, whichever occurs first.

To Service Air Cleaner (Figure 5-3):

1. Stop engine, wait for parts to stop moving, and disconnect spark plug wire.
2. Unscrew mounting screws and/or remove knobs (D). Remove covers (E). Remove paper cartridge (B) and foam pre-cleaner (A). Separate foam pre-cleaner from paper cartridge.
3. Wash foam pre-cleaner (A) in liquid

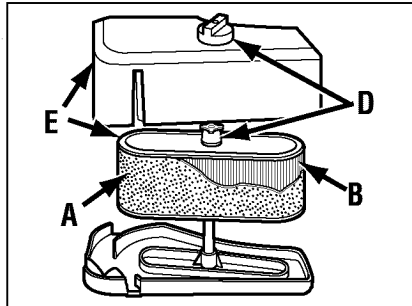

Figure 5-3: Briggs and Stratton air cleaner assembly.

detergent and warm water. Squeeze dry in a clean cloth.

4. Saturate foam pre-cleaner in clean engine oil. Wrap in clean, absorbent cloth and squeeze to remove all excess oil.
5. Replace paper cartridge (B), if necessary.
6. Reassemble air cleaner components. Tighten knobs/screws (D) securely. Secure cover assembly (E) on air cleaner body.

### SPARK PLUG

Inspect the spark plug (Figure 5-4) after every 100 hours of operation. Be sure the gap is set at .030". Do not reuse plug if it is severely worn or damaged.

Best results are obtained with a new plug. See Engine Owner's Manual to determine proper replacement plug. Use of incorrect plug can cause engine damage.

NOTE: Do not clean spark plug in machines which use abrasive grit. Clean spark plug by scraping or wire brushing, or washing with a commercial solvent.

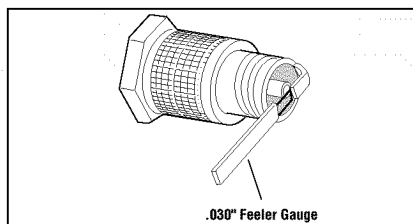

Figure 5-4: Spark plug.

### WARNING

Charge battery only with charger supplied with machine. Do not short circuit battery wires. Remove any jewelry before working on or near the battery or electric start system. Failure to follow these instructions could result in personal injury or property damage.

### BATTERY (if applicable)

Charge battery if unit is to be stored for longer than three weeks. During the mowing season, the battery is kept charged by the charging system on the engine.

To Charge Battery:

1. Plug charger connector into wire harness connector located below ignition switch in handlebar console.
2. Plug charger into 120V wall outlet. (Note that battery charger is designed for use indoors and should not be exposed to rain or snow.)
3. Charge battery for 24-48 hours if unit is to be stored for longer than three weeks.
4. After charging, unplug charger from outlet, then unplug charger from connector on wire harness located below handlebar console.

### CARBURETOR

The carburetor is adjusted at the factory. It should not need to be reset. If black exhaust is noted, check the air cleaner first. An over-rich mixture is usually caused by a poorly serviced or clogged air cleaner element, not an improperly adjusted carburetor. If readjustment is necessary, refer to Engine Owner's Manual or contact your engine dealer.

## Section 5: Maintenance

### ⚠ WARNING



Before inspecting, cleaning or servicing the machine, shut off engine, wait for moving parts to stop, disconnect spark plug wire and move wire away from spark plug. Remove ignition key (electric start models). Failure to follow these instructions can result in serious personal injury or property damage.

### ENGINE STORAGE

If engine will be unused for 30 days or more, prepare it for storage by following the recommended procedures found in the Engine Owner's Manual.

### MOWER SERVICE

The following maintenance/repair procedures can be performed by either the owner or an authorized service dealer. See an authorized service dealer for complete mower service.

### TIPPING MOWER FOR SERVICE

#### ⚠ WARNING

Before servicing underside of mower, stop engine, wait for all parts to stop moving, and disconnect spark plug wire. Remove ignition key from keyswitch on electric start models. Failure to follow this instruction could result in personal injury or property damage.

When servicing the underside of the mower for any reason, the mower should only be tipped backward on its rear wheels (and securely propped up to prevent it from falling). Tipping the mower forward or to either side could result in damage to engine.

TIP: Before tipping mower, install a small plastic sandwich style bag under the gas cap and tighten securely. This will virtually eliminate any fuel weepage from the cap. *Be sure to remove the plastic bag before re-using mower.*

### BELT COVER REMOVAL

#### ⚠ WARNING

Do not operate unit without belt cover installed. Failure to follow this instruction could result in personal injury or property damage.

The belt cover must be removed to perform several maintenance procedures.

To Remove Belt Cover:

**1. Stop engine, wait for all parts to stop moving, and disconnect spark plug wire.**

**2. Remove four screws (R, Figure 5-5) and remove cover.**

To Reinstall Belt Cover:

**1. Position belt cover in place.**

**2. Secure with the four screws removed earlier.**

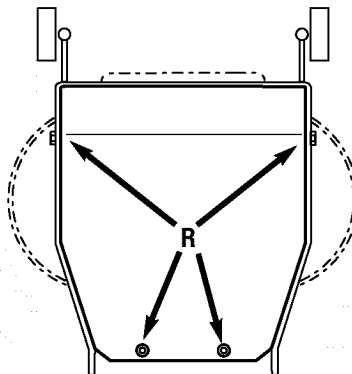

Figure 5-5: Belt cover removal.

### BLADE SPINDLE BELT REPLACEMENT

Follow this procedure to remove and replace the blade spindle drive belt (remove blade drive belt first; see "Blade Drive Belt Replacement" in this Section).

**1. Stop engine, wait for all parts to stop moving and disconnect spark plug wire.**

**2. Remove belt cover (see "Belt Cover Removal").**

**3. Align sight holes (O, Figure 5-6) in pulley with spindle housing-to-mower deck mounting bolts (L).**

**4. Loosen screw (J) and rotate arm (K) to the rear.**

**5. Loosen four mounting bolts (L) securing spindle housing (beneath mower deck) to mower deck.**

**6. Slide spindle housing (with pulley attached) toward center.**

**7. Replace belt (N) with new belt.**

**IMPORTANT: SET BLADES PERPENDICULAR (90°) TO EACH OTHER.**

**8. Rotate arm (K) to move spindle housing and apply tension to belt. Belt cogs and pulley grooves must mesh together. When applying moderate finger tension (8-12 lbs.), belt should deflect approximately 1/2" (12.7 mm) at (P), midpoint of deck.**

**9. Tighten bolts (L) to 15 ft.-lbs. (20.3 Nm). Tighten screw (J).**

**10. Blades must not contact deck. Check and readjust as needed.**

**11. Reinstall blade drive belt and belt cover (removed earlier).**

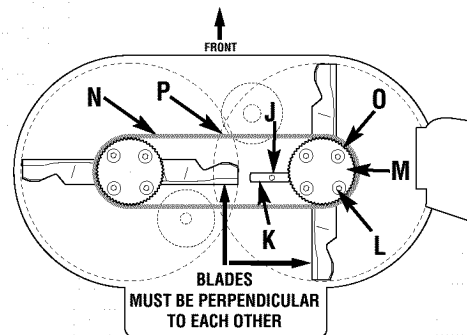

Figure 5-6: Blade Spindle Belt.

### **WARNING**



Before inspecting, cleaning or servicing the machine, shut off engine, wait for moving parts to stop, disconnect spark plug wire and move wire away from spark plug. Remove ignition key (electric start models). Failure to follow these instructions can result in serious personal injury or property damage.

### **BLADE DRIVE BELT REPLACEMENT**

Follow this procedure to remove and replace the blade drive belt. An assistant will be needed.

To Remove Belt:

- 1. Stop engine, wait for all parts to stop moving, and disconnect spark plug wire.**
- Disengage blade drive control (Figure 5-7) by releasing all controls on the mower.
- Remove belt cover (see "Belt Cover Removal").
- Loosen belt guides (B and C, Figure 5-8).
- Move flap bracket (N, Figure 5-8) out of the way by loosening two screws (M).
- Remove belt (A, Figure 5-8) from around sheaves.

To Install Belt:

- Route belt (A, Figure 5-8) around sheaves as shown.
- Have an assistant hold down Operator Presence Control and then push the Blade Drive Control forward until it latches in place (Figure 5-7).
- With the Blade Drive Control lever engaged, adjust and tighten belt guide (B) to  $1/32 - 1/16$ " away from tensioned belt. (Be sure that belt does not contact belt guide when belt is under tension.) Secure belt guide (C) rotated into position as shown in Figure 5-8.
- Disengage Blade Drive Control.
- Re-tighten two screws (M, Figure 5-8) that secure flap bracket (N).
- Reinstall belt cover securely.

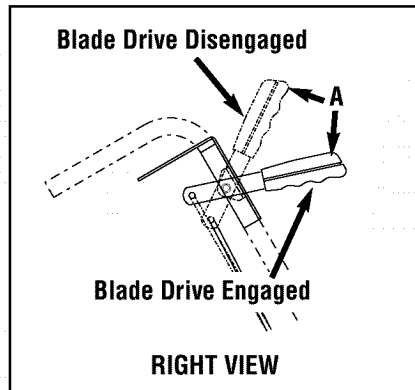

Figure 5-7: Blade Drive Control.

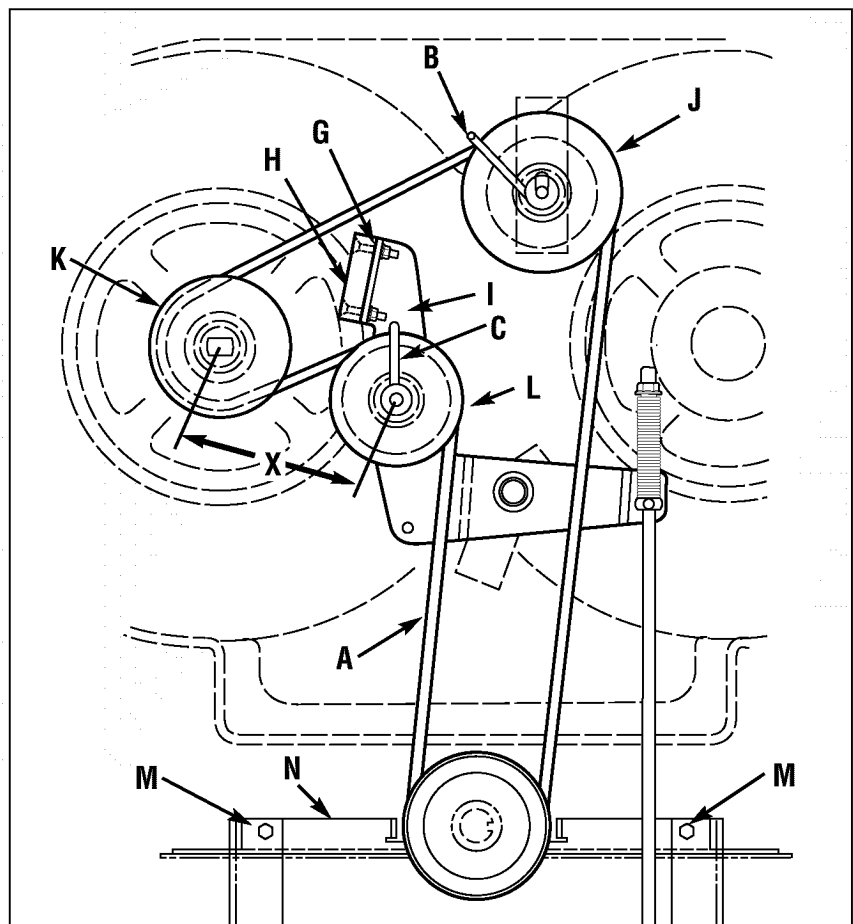

Figure 5-8: Blade drive.

## Section 5: Maintenance

### WARNING



Before inspecting, cleaning or servicing the machine, shut off engine, wait for moving parts to stop, disconnect spark plug wire and move wire away from spark plug. Remove ignition key (electric start models). Failure to follow these instructions can result in serious personal injury or property damage.

### BLADE BRAKE REPLACEMENT

Follow this procedure to install a new blade brake.

To Remove Blade Brake:

1. **Stop engine, wait for all parts to stop moving, and disconnect spark plug wire.**
2. Remove belt cover as described in "Belt Cover Removal" instructions.
3. Remove hardware (G, Figure 5-8) securing blade brake (H).
4. Remove old brake (H) from idler arm (I).

To Install Brake:

1. Position new brake (H) in place on idler arm (I).
2. Center brake in sheave groove and secure brake (H) with hardware (G) removed earlier.
3. Reinstall belt cover securely.
4. Test operation of blade brake (see "Blade Brake Control Test" in Operation section).

### BLADE DRIVE BELT ADJUSTMENT

If the blade drive belt is slipping due to lack of belt tension, follow the steps below.

1. **Stop engine, wait for all parts to stop moving, and disconnect spark plug wire.**
2. Remove belt cover as described in "Belt Cover Removal" instructions.
3. With mower on level ground, adjust blade cutting height at about 3" (measure from ground to flat portion of blade).
4. With the Blade Drive Control (Figure 5-7) in the disengaged position, set a gap of 1/8" between the spring (F, Figure 5-9) and flat washer (E) by adjusting the nut (D).
5. Reinstall the belt cover securely.

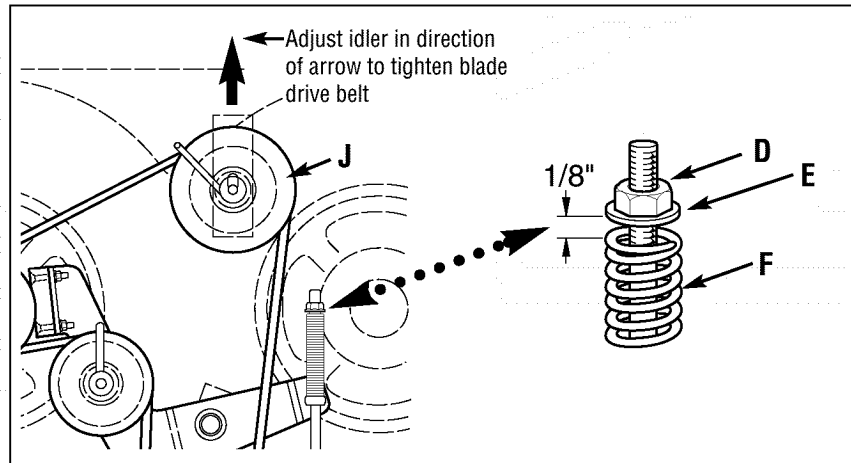

Figure 5-9: Blade drive adjustment.

6. Test the operation of the blade brake (see "Blade Brake Control Test" in the Operation section).
7. If the drive belt slips during operation, it may be necessary to relocate idler (J, Figure 5-9) in the slot provided in the mounting bracket. **With the engine stopped and the spark plug wire disconnected**, loosen the hardware on the idler (J) and slide it forward to take up slack in the belt.
8. Engage the blade drive and measure the distance (X, Figure 5-8) between the centers of pulleys (K) and (L). The distance should be 5-1/2 to 5-5/8". After obtaining the correct dimension, reinstall the belt cover securely and test the operation of the blade brake.

### BLADE DRIVE CONTROL LEVER ADJUSTMENT

Make the following adjustment if the Blade Drive Control Lever releases during operation.

1. **Stop engine, wait for all parts to stop moving, and disconnect spark plug wire.**
2. Engage the Operator Presence Control and the Blade Drive Control. Without releasing the controls, look inside the cutout at the rear of the frame

and make sure the Operator Presence Control latches (A and B, Fig. 5-10) are fully engaged at point (C). If they are not fully engaged, improper operation or premature wear could result. To adjust, loosen hex nut (D) and shorten length of control rod (E). To avoid over-adjusting, turn rod only 1 to 2 turns per adjustment.

3. Tighten hex nut securely after adjusting control rod.
4. Test by releasing the Operator Presence Control. If properly adjusted, the Blade Drive Control will disengage when the Operator Presence Control is released. Re-adjust as necessary by repeating Steps 2 and 3.

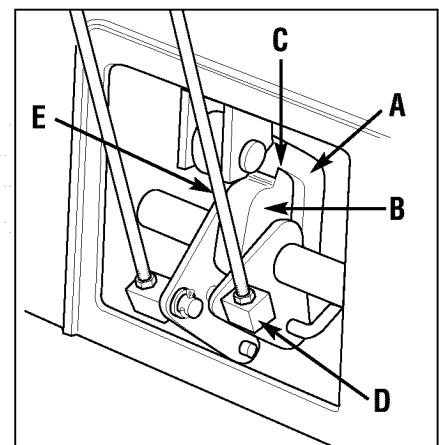

Figure 5-10: Blade Drive Control Lever adjustment.

### **WARNING**



Before inspecting, cleaning or servicing the machine, shut off engine, wait for moving parts to stop, disconnect spark plug wire and move wire away from spark plug. Remove ignition key (electric start models). Failure to follow these instructions can result in serious personal injury or property damage.

### WHEEL DRIVE BELT REPLACEMENT

Follow this procedure to replace the wheel drive belt.

1. **Stop engine, wait for all parts to stop moving, and disconnect spark plug wire.**
2. Release all mower controls.
3. Remove belt cover as described in "Belt Cover Removal" instructions.
4. Locate wheel drive belt (O, Figure 5-11) and remove it from top sheave of engine sheave, back-sided idlers (P and Q) and transmission sheave (R).
5. Install new belt as shown in Figure 5-11. Belt must be installed "inside out" – "V" side of belt lies against engine sheave only. Flat side of belt lies against transmission sheave (R) and back-sided idlers (P and Q).
6. Make sure belt is inside belt guide (S, Figure 5-11).
7. Reinstall belt cover securely.
8. An adjustment to the drive belt may be necessary. See "Wheel Drive Belt Adjustment" in this Section.

### WHEEL DRIVE BELT ADJUSTMENT

The wheel drive belt requires an adjustment if loss of drive belt tension (slippage) occurs. This is most noticeable when more traction is required (such as going up slopes).

To Test Wheel Traction:

1. Park machine on a paved (concrete, etc.) surface with front edge up against a sturdy wall, fence, etc.
2. Put Gear Select Lever in No. 1 setting.  
**IMPORTANT: DO NOT PARK AGAINST A PAINTED OR SIDED WALL. TESTING THE WHEEL DRIVE SYSTEM REQUIRES MACHINE TO BE FORCIBLY PUSHED AGAINST WALL. DAMAGE TO PAINT OR SIDING COULD RESULT.**
3. With engine running, and machine placed firmly up against wall, hold down Operator Presence Control and fully en-

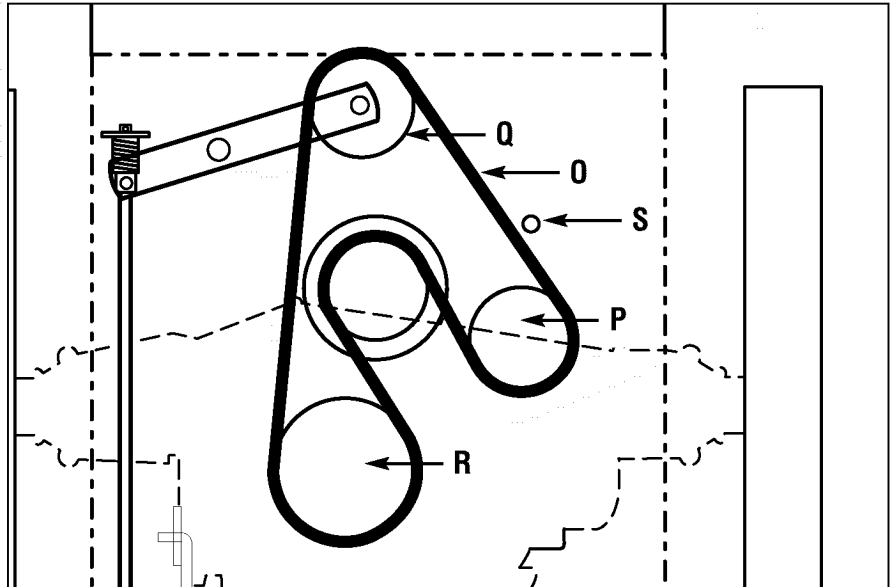

Figure 5-11: Wheel drive belt replacement.

gage wheel drive by squeezing Wheel Drive Control until it contacts handlebar.  
4. Wheels should slip on paved surface. If they do not, an adjustment is required.

To Adjust Wheel Drive Belt:

1. **Stop engine, wait for all parts to stop moving, and disconnect spark plug wire.**
2. Remove cotter pin (A, Figure 5-12A) from upper end of Wheel Drive Control rod. Slide rod out of lever assembly.
3. Loosen jam nut (D, Figure 5-12).
4. Thread rod (E, Figure 5-12) one or two turns clockwise for more tension or counterclockwise for less tension.
5. Insert rod back into hole in Wheel Drive Control lever and install cotter pin. Bend ends of cotter pin to secure.
6. Retest wheel traction. Repeat adjustment procedure, if necessary. Most comfortable operation will be obtained when the adjustment allows the lever to just make contact with the handgrip as sufficient wheel traction is achieved. When adjustment is complete, tighten jam nut (D) firmly against block (B).

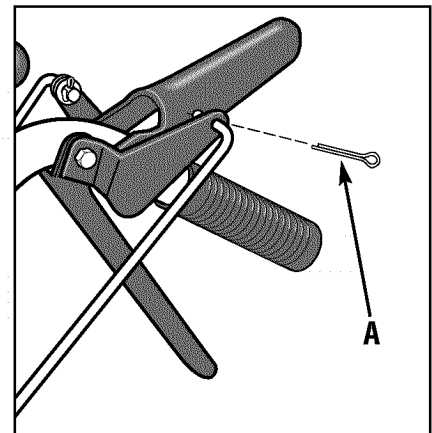



Figure 5-12A

### WHEEL BRAKE ADJUSTMENT

This adjustment may be required if the machine does not hold on a hill with the Operator Presence Control disengaged, or if the brake drags with the Operator Presence Control engaged and the transmission in neutral.

1. **Stop engine, wait for all parts to stop moving, and disconnect spark plug wire.**
2. Disengage (release) the Operator Presence Control (M, Figure 5-13).

## Section 5: Maintenance

 <b>WARNING</b>	<p>Before inspecting, cleaning or servicing the machine, shut off engine, wait for moving parts to stop, disconnect spark plug wire and move wire away from spark plug. Remove ignition key (electric start models). Failure to follow these instructions can result in serious personal injury or property damage.</p>
	

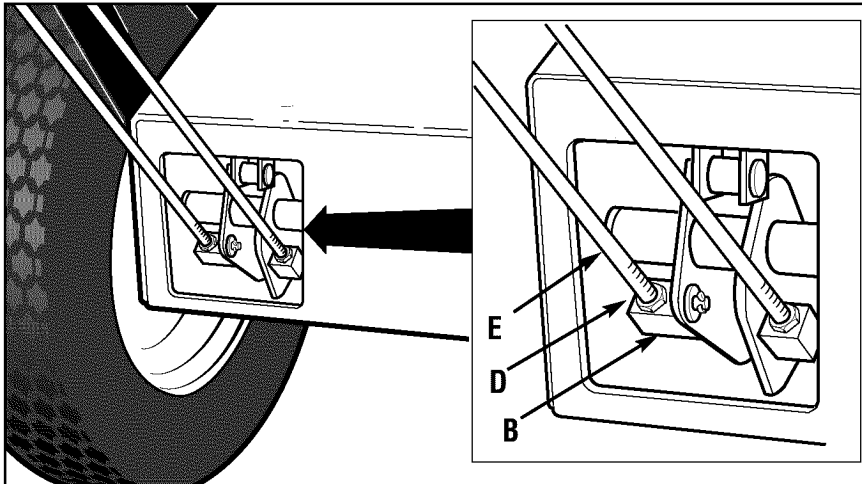

Figure 5-12: Wheel drive belt adjustment.

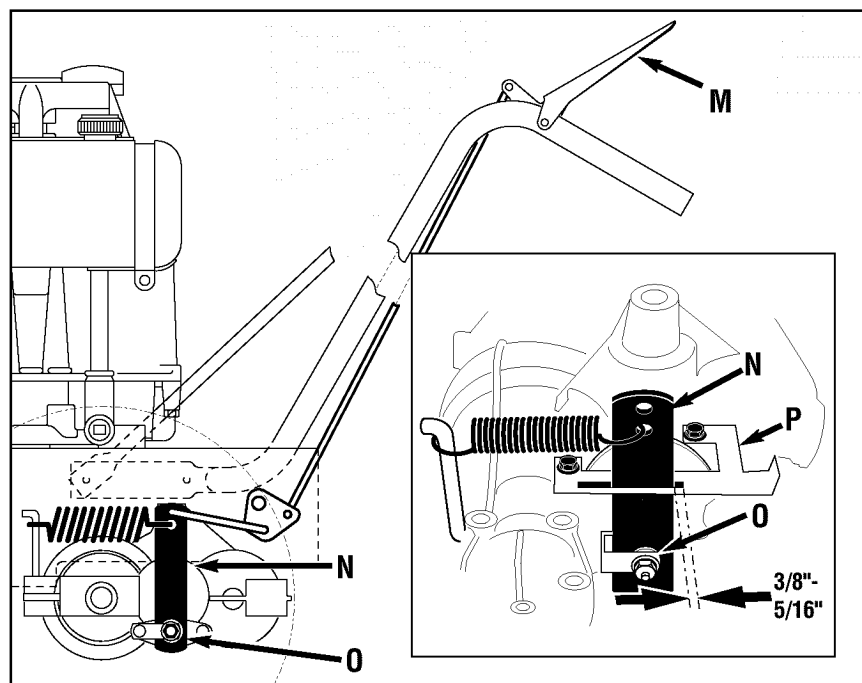

Figure 5-13: Wheel brake adjustment.

3. Slowly adjust at nut (O), if necessary, until the distance between the back of brake arm (N) and bracket (P) is 3/8" - 5/16". Use small adjustments (1/4 turn maximum). NOTE: It may be necessary to relieve spring tension when decreasing distance. To do so, have an assistant engage the Operator Presence Control while you adjust the nut.

### TRANSMISSION NEUTRAL ADJUSTMENT

Follow this procedure to adjust neutral on the transmission.

1. Stop engine, wait for all parts to stop moving, and disconnect spark plug wire.
2. Rotate shift rod (I, Figures 5-14 and

5-15) clockwise until it stops in the neutral (N) position (from forward gear positions).

3. Hold down Operator Presence Control (M, Figure 5-13) and push unit forward and backward. Unit should move freely. If not, continue with Step 4.

4. Remove cotter pin securing shift link (P, Figure 5-15) to shift rod (I).

5. Move shift arm (X) back and forth as necessary into each detent until transmission is in neutral. NOTE: Moving shift arm (X) clockwise all the way to the left, and then one notch back counter-clockwise, should put transmission into neutral. When transmission is in neutral, unit will move freely when pushed while holding the Operator Presence Control lever down. If transmission is NOT in neutral, there will be a slight drag on the wheels when pushing unit.

6. When shift arm (X) is in neutral position, rotate shift link (P) until hooked end fits back into hole in bottom end of shift rod (I). NOTE: Shift rod (I) must be held in the neutral position (see Figure 5-14) while shift link (P) is adjusted.

7. Secure shift link (P) into shift rod (I) with cotter pin removed earlier.

8. Re-check neutral by pushing unit back and forth and shifting lever (I) from reverse to neutral. A small fine-tune adjustment may be required.

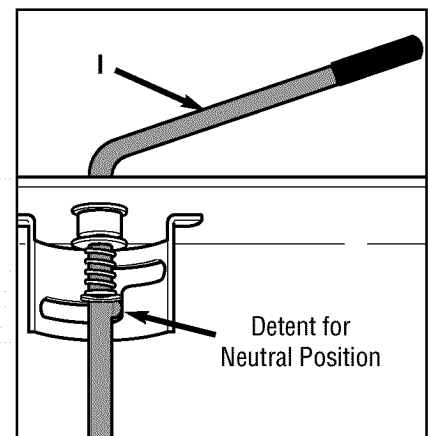

Figure 5-14: Lever in neutral (N) position.



**⚠ WARNING** Before inspecting, cleaning or servicing the machine, shut off engine, wait for moving parts to stop, disconnect spark plug wire and move wire away from spark plug. Remove ignition key (electric start models). Failure to follow these instructions can result in serious personal injury or property damage.

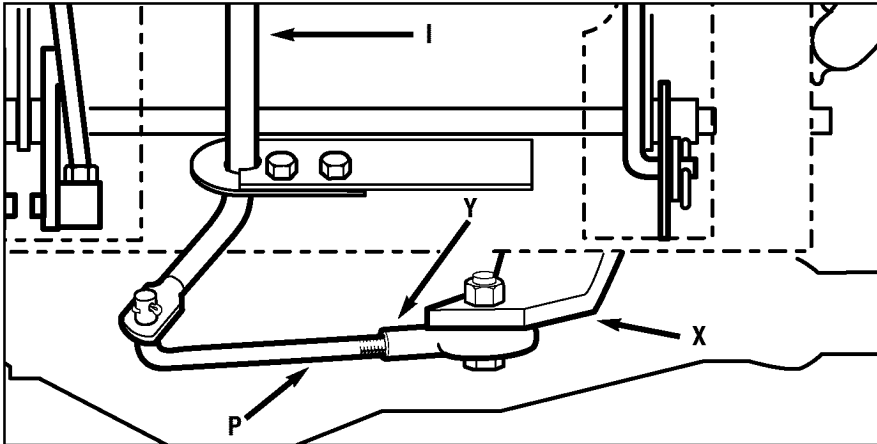

Figure 5-15: Transmission neutral (N) adjustment.

## MOWER BLADES

**⚠ WARNING**

Mower blades are sharp.

- When working near blades, wear heavy leather gloves or wrap blades in thick rags to protect yourself from the sharp edges.
- Wear eye protection when sharpening blades.

Examine mower blades before operation. For efficient mowing, cutting edges of blades should always be kept sharp. Check for blade wear or damage. See Figure 5-16. Replace a severely worn or damaged blade with a new one.

To Inspect Blades:

1. Stop engine, wait for all parts to stop moving, and disconnect spark plug wire.
2. Tip mower on rear wheels by following instructions “Tipping Mower For Service” in this Section of Manual.

To Remove Blades:

Remove bolt (Figure 5-18) and washer(s). Remove mower blade.

To Sharpen Blades:

Grind or file the same amount from each blade end to maintain blade balance. An unbalanced mower blade produces excessive vibration and may damage spindle bearings. Sharpen cutting edge straight across, parallel to rear edge of mower blade. See Figure 5-16. After sharpening, blade balance must be checked.

**IMPORTANT:** PROFESSIONAL SHARPENING SERVICES OR YOUR AUTHORIZED DEALER ARE EQUIPPED TO SHARPEN MOWER BLADES SAFELY.

To Install Blades:

Blades must be installed perpendicular to each other (see Figure 5-17).

Install mower blade as shown in Figure 5-18 with flat side down. Install washer on bolt. Tighten bolts to a torque value of 35 ft. lbs. (47 Nm).

NOTE: If top bolt is removed, reinstall using LOCTITE #242 thread sealant.

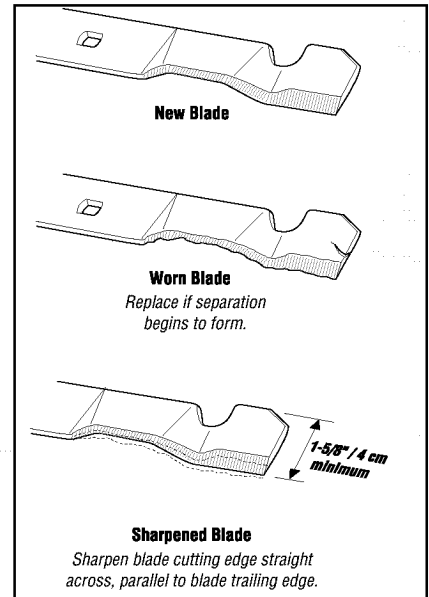

Figure 5-16: Blade Inspection

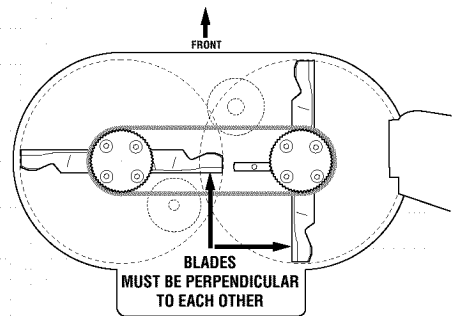

Figure 5-17

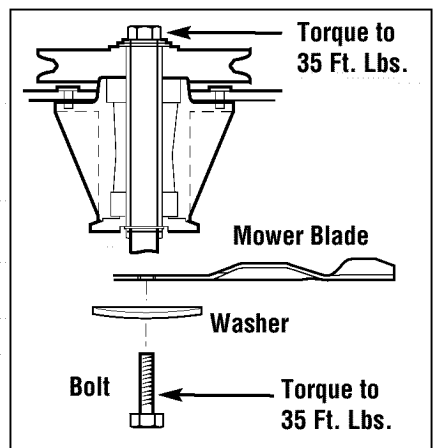

Figure 5-18: Blade spindle.

## Section 5: Maintenance



**WARNING** Before inspecting, cleaning or servicing the machine, shut off engine, wait for moving parts to stop, disconnect spark plug wire and move wire away from spark plug. Remove ignition key (electric start models). Failure to follow these instructions can result in serious personal injury or property damage.

### CLEANING UNDERSIDE OF MOWER DECK

#### **WARNING**

Mower blades are sharp.

When working near blades, wear heavy leather gloves or wrap blades in thick rags to protect yourself from the sharp edges.

Frequently check, and clean if necessary, the underside of the mower deck. Grass build-up in this area can affect the cutting performance. Before inspecting or cleaning, make sure that the engine is shut off and the spark plug wire is disconnected from the spark plug.

Inspection/Cleaning of Mower Deck:

1. **Stop engine, wait for all parts to stop moving, and disconnect spark plug wire.**
2. Tip mower on rear wheels by following instructions "Tipping Mower For Service" in this Section.
3. Use a plastic or metal scraper to remove grass build-up from deck or blades. If needed, spray with a garden hose.

### LUBRICATION

Oil and grease the mower according to the recommendations listed in the Lubrication Chart on the next page.

- **Stop engine, wait for all parts to stop moving, and disconnect spark plug wire before performing any lubrication procedures.**
- The transmission has been factory sealed and requires no lubrication. If a leak should develop, contact the factory or your local authorized dealer for service information.

### OFF-SEASON STORAGE

- **Stop engine, wait for all parts to stop moving, and disconnect spark plug wire before performing any storage procedures. Review the storage safety rules in the Safety Section of this Manual.**

- If engine will be unused for 30 days or more, prepare it for storage by following the recommended procedures found in the Engine Owner's Manual.

- Inspect all parts for damage, breakage, and wear. Tighten or replace fasteners. Contact the factory or your local authorized dealer for factory-approved replacement parts.

- Clean the exterior of the mower thoroughly and touch up all chipped or scratched surfaces to prevent rust from forming.

#### **WARNING**

Never store machine with fuel in the fuel tank inside a building where fumes may reach an open flame or spark, or where ignition sources are present such as hot water and space heaters, furnaces, clothes dryers, stoves, electric motors, etc.

## Section 5: Maintenance

 <b>WARNING</b>	<p>Before inspecting, cleaning or servicing the machine, shut off engine, wait for moving parts to stop, disconnect spark plug wire and move wire away from spark plug. Remove ignition key (electric start models). Failure to follow these instructions can result in serious personal injury or property damage.</p>
--	---

### Lubrication Chart

ITEM	INTERVAL	LUBRICATION TYPE	AMOUNT REQUIRED
Engine Crankcase	First 2 hours	Change Oil	See Engine Manual
	25-50 hours	Change Oil (Lubrication Intervals Vary with Operating Conditions and Type of Oil Used)	Change oil more often in extremely dirty or dusty conditions.
Front Wheel Bearings	50 hours	Grease	1-3 Strokes*
Control Linkages/Pivots	25 hours	Light Oil	A Few Drops
Transmission Output Shaft	100 hours or Annually	Grease	1-3 Strokes*

\* A hand-type grease gun is recommended.

## Section 5: Maintenance

	<p><b>WARNING</b> Before inspecting, cleaning or servicing the machine, shut off engine, wait for moving parts to stop, disconnect spark plug wire and move wire away from spark plug. Remove ignition key (electric start models). Failure to follow these instructions can result in serious personal injury or property damage.</p>
---	--

ATTENTION! This chart describes service guidelines only. It does not provide complete service information. Complete service is available from your authorized mower or engine dealer. Before performing any of the maintenance procedures, refer to the appropriate information contained in this Manual or the Engine Owner's Manual for the correct safety precautions and maintenance procedures.

### Maintenance Chart

INTERVAL*	ITEM	SERVICE
Each use	Mower Blade Loose or Missing Hardware Belts Engine Oil Level Controls Mulching Cover	As Required Tighten or Replace Check Check Check for Proper Operation Check for Proper Cover Installation
1st 2 hours	Engine Oil	Change
25 hours	Engine Oil*** Foam Air Filter**** Mower Blade(s) Control Linkages and Pivots	Change Clean Sharpen and Balance Lube with Light Oil
50 hours	Engine Oil*** Blade Drive Belt Adjust Engine Cooling Fins Grease Fittings**	Change Adjust Tension Clean Grease
Annually or 100 hours	Air Filter Element**** Spark Plug Transmission Output Shaft	Replace Clean/Replace, Re-gap Grease
Monthly	Linkages Belts	Adjust Check/Replace, Adjust
Annually or 50 hours	Front Wheel Bearings	Grease

\*Interval describes running time.

\*\*A hand-type grease gun is recommended when greasing your unit. High-pressure type grease guns could cause damage to fittings/seals.

\*\*\*Consult engine manual for more detailed engine service information.

\*\*\*\*Clean more often under dusty conditions or when airborne debris is present. Replace air cleaner parts, if very dirty.

## Section 5: Maintenance



**WARNING** Before inspecting, cleaning or servicing the machine, shut off engine, wait for moving parts to stop, disconnect spark plug wire and move wire away from spark plug. Remove ignition key (electric start models). Failure to follow these instructions can result in serious personal injury or property damage.

**ATTENTION!** This table describes service guidelines only. It does not provide complete service information. Complete service is available from your authorized mower or engine dealer. Before performing any of the corrections in this table, refer to the appropriate information contained in this Manual or the Engine Owner's Manual for the correct safety precautions and operating or maintenance procedures.

### Troubleshooting Chart

Possible cause	Symptom															
	Engine does not turn over.	Engine turns over but will not start.	Engine starts only after repeated tries.	Engine runs roughly.	Engine stalls in a few seconds.	Engine runs but unit does not move.	Wheel drive always engaged.	Engine stalls when hot.	Engine overheats.	Engine does not shut off.	Blade drive inoperative.	Blade drive always engaged.	Battery not charging (if applicable).	Poor mowing performance.	Blade does not stop when Operator Presence Control is released.	Excessive vibration.
Engine malfunction (refer to engine manual).	●	●	●	●	●			●	●	●						●
Improperly adjusted drive linkage.						●	●				●	●		●	●	●
Dirty engine cooling fins or flywheel screen.								●								
Faulty ignition.	●	●	●	●	●			●	●							
Faulty spark plug.	●	●	●	●				●								
Empty fuel tank.	●	●			●			●								
Battery or charging malfunction (if applicable).	●	●							●			●				
Improperly adjusted or dirty carburetor.		●	●	●	●				●							
Improper oil level.									●							●
Dirty air cleaner element.		●		●	●				●							
Improperly adjusted choke (if applicable).		●	●	●	●				●							
Transmission malfunction.						●	●									
Improperly adjusted drive linkage.						●	●				●	●				●
Broken, loose or worn belt(s).				●		●	●				●	●		●		
Dull blade(s).														●		●
Throttle control out of adjustment.		●	●						●							
Blade/brake system out of adjustment.											●	●			●	
Blade(s) out of balance.														●		●
Loose hardware.											●	●				●

# Wide-Cut Combination Mower

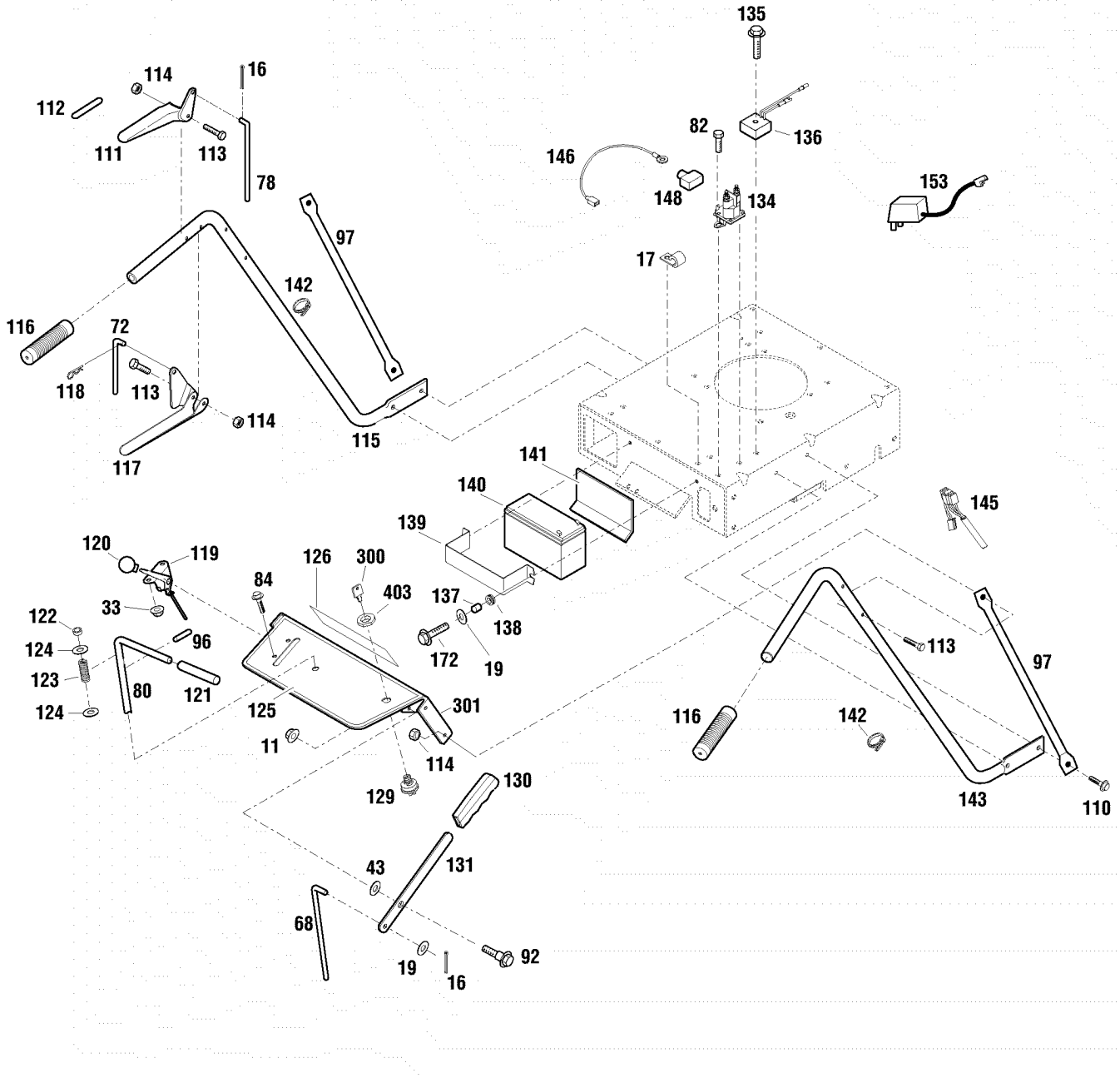

## HANDLEBAR AND CONSOLE ASSEMBLY

## HANDLEBAR AND CONSOLE ASSEMBLY

Ref.	Part	Description	Qty.	Ref.	Part	Description	Qty.
11	1186393	Flange Locknut, 3/8-16.....	1	125	777S00003	Warning Decal (A) .....	1
16	1185147	Cotter Pin, 3/32 x 5/8 .....	2	126	777D06080	Logo Decal (A) (B) .....	1
17	1721252	J-Clip.....	1	129	1734196	Ignition Switch (B) .....	1
19	1107382	Flat Washer, 5/16 .....	4	130	1764984	Handle Grip .....	1
33	1186389	Flange Locknut, 1/4-20.....	2	131	1768223	Mower Engage Lever.....	1
43	1702646	Flat Washer, 1/2 .....	1	134	1752137	Solenoid (B) .....	1
68	1769888	Upper Blade Rod .....	1	135	1747027	Thread-Cut. Screw, 1/4-20 x 1-1/2 (B)....	1
72	1773607	Upper Transmission Rod.....	1	136	1768464	Regulator .....	1
78	1769872	Upper Brake Rod .....	1	137	1749778	Spacer (B) .....	2
80	1769874	Shift Rod .....	1	138	1769080	Grommet (B) .....	2
82	1724492	Thread Cut. Screw, 1/4-20 x 1/2 (B).....	2	139	1915696010	Battery Bracket (B) .....	1
84	1186308	Flange Lock Screw, 1/4-20 x 1/2 .....	2	140	1915750	Battery (B).....	1
92	1703051	Shoulder Bolt .....	1	141	1769081	Battery Pad (B).....	1
96	1185279	Roll Pin, 1/4 x 2-1/4 .....	1	142	1735531	Plastic Tie.....	5
97	1915545010	Brace, Handlebar (A) (B) .....	2	143	1764923010	Right Handlebar (A) (B).....	1
110	1186329	Flange Lock Screw, 5/16 x 3/4 .....	4	145	1915758	Wiring Harness (B).....	1
111	1770445001	Control Handle .....	1	146	1915759	Lead (B) .....	1
112	777I00001	Operator Presence Control Decal .....	1	148	1734364	Boot (B).....	1
113	1915793	Screw, 1/4-20 x 1-3/4, Grade 8 .....	6	153	1768449	Battery Charger (shipped loose) (B).....	1
114	1734398	Locknut, 1/4-20 .....	2	172	1724491	Screw, 5/16-18 x 3/4".....	1
115	1764922010	Left Handlebar (A) (B) .....	1	300	1753986	Ignition Key (B) .....	1
116	1703539	Handle Grip .....	2	301	1768640	Console Assembly (Incl. Ref. 125) (A) ...	1
117	1773605001	Control Handle .....	1		1768493	Console Assembly (Incl. Ref. 125) (B) ...	1
118	1717897	Hair Pin, 5/64 .....	1	403	1770592	Nut, Ignition Switch .....	1
119	1768191	Throttle Control .....	1				
120	1737118	Knob.....	1				
121	1737041	Handle Grip .....	1				
122	1715716	Nylon Bushing.....	1				
123	1721492	Compression Spring.....	1				
124	736-0326	Flat Washer, 1/2 .....	1				

(A) Model 753B  
 (B) Model 34343

# Wide-Cut Combination Mower

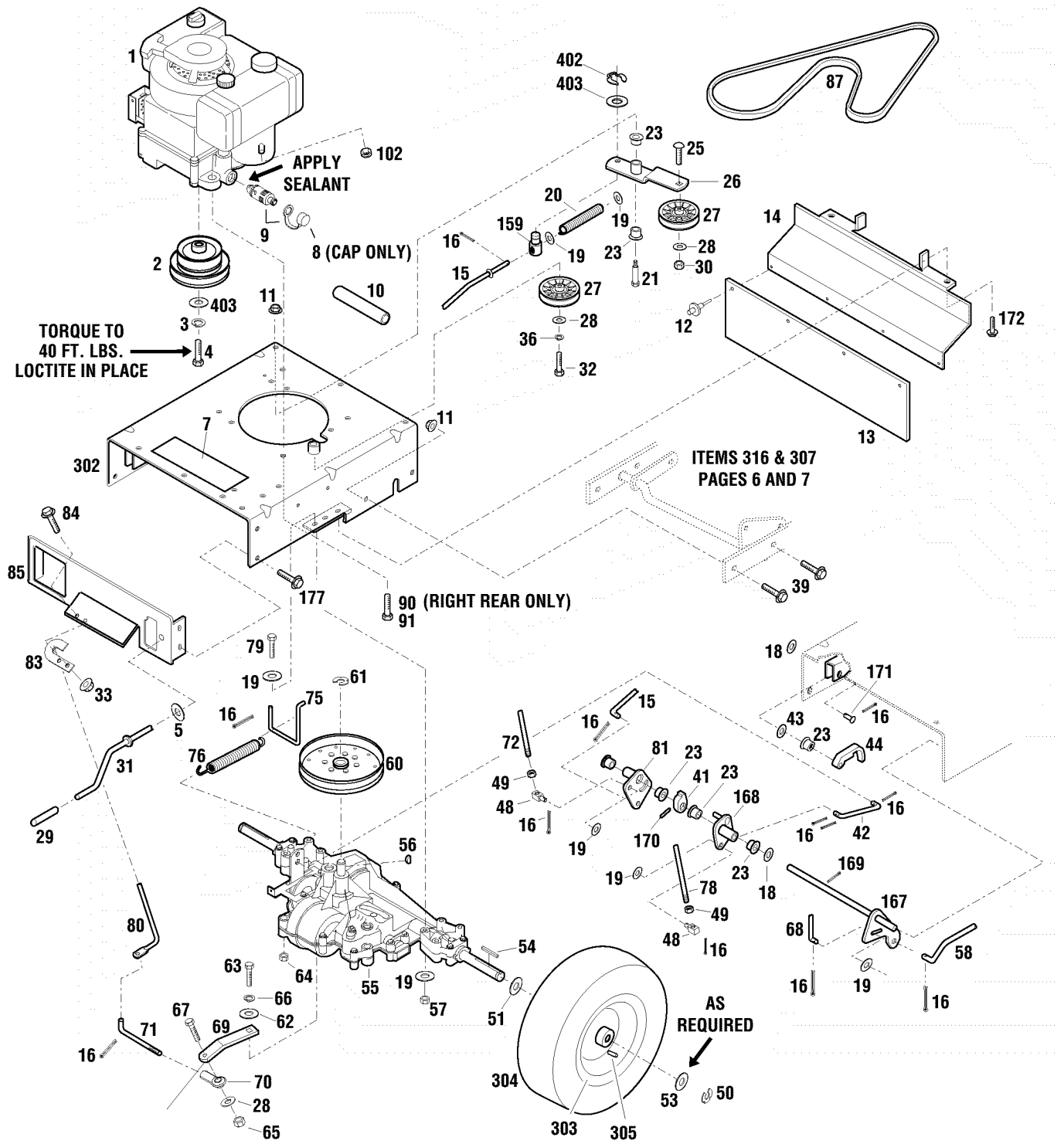

## DRIVE ASSEMBLY



## DRIVE ASSEMBLY

Ref.	Part	Description	Qty.	Ref.	Part	Description	Qty.
1	*	Engine, Electric Start.....	1	57	1732499	Top Locknut, 5/16-18.....	4
	*	Engine, Recoil Start.....	1	58	1770247	Lower Blade Rod.....	1
2	1769904	Engine Pulley.....	1	60	1770326	Transaxle Pulley.....	1
3	736-0171	Lock Washer, 7/16.....	1	61	1118808	Retaining Ring.....	1
4	1740949	Bolt, 7/16-20 x 1-3/4.....	1	62	736-0463	Flat Washer, 1/4.....	3
5	1773599	Washer, Nylon.....	1	63	1100002	Screw, 1/4-28 x 3/4.....	1
7	777S00006	Warning Decal.....	1	64	712-3004A	Flange Locknut, 5/16-18.....	1
8	1766326	Oil Valve Cap.....	1	65	712-3000	Locknut, 3/8-16.....	2
9	1768865	Oil Valve (Incl. Ref. 8).....	1	66	736-0329	Lock Washer, 1/4.....	1
10	1769006	Oil Drain Hose.....	1	67	712-3005	Screw, 3/8 x 1-1/4.....	1
11	1186393	Flange Locknut, 3/8-16.....	5	68	1769888	Upper Blade Rod.....	1
12	1727379	Pop Rivet, 3/16.....	4	69	1768140	Transmission Arm.....	1
13	1769870	Flap.....	1	70	1767837	Ball Joint.....	1
14	1769869001	Flap Bracket.....	1	71	1768628	Shift Link Rod.....	1
15	1769885	Lower Transmission Rod.....	1	72	1769873	Upper Transmission Rod.....	1
16	1185147	Cotter Pin, 3/32 x 5/8.....	8	75	1768624	Spring Attachment Rod.....	1
18	1890234	Flat Washer, 1/2.....	1	76	1768636	Extension Spring.....	1
19	1107382	Flat Washer, 5/16.....	5	78	1769872	Upper Brake Rod.....	1
20	1711864	Compression Spring.....	1	79	1111609	Screw, 5/16-18 x 2-3/4.....	2
21	1763219	Shoulder Bolt.....	1	80	1769874	Shift Rod.....	1
23	1715538	Nyliner, 1/2.....	2	81	1769875	Clutch Arm Pivot.....	1
25	1748393	Carriage Bolt, 3/8-16 x 1-3/4.....	1	83	1768630001	Shift Rod Bracket.....	1
26	1918370	Idler Arm.....	1	84	1186308	Flange Lock Screw, 1/4-20 x 1/2.....	2
27	1756151	Idler Pulley.....	2	85	1769852010	Backplate (A) (B).....	1
28	736-3050	Flat Washer, 3/8.....	3	87	1770334	V-Belt.....	1
29	1715685	Plastic Grip.....	1	90	1768194	Thread Forming Screw, 3/8-16 x 1-1/2..	1
30	712-3000	Top Locknut, 3/8-16.....	1	91	1762042	Thread Forming Screw, 3/8-16 x 1.....	3
31	1915831	Lift Crank Assembly.....	1	102	1186229	Hex Nut, 1/4-20.....	1
32	710-0347	Bolt, 3/8-16 x 1-3/4.....	1	159	1916897	Pivot.....	1
33	1186389	Flange Locknut, 1/4-20.....	4	167	1769882	Pivot Shaft Assembly.....	1
36	736-0169	Lock Washer, 3/8.....	1	169	1100350	Cotter Pin.....	3
39	1186347	Flange Lock Screw, 3/8-16 x 1.....	4	168	1769878	Brake Arm.....	1
41	1769881	Interlock Cam.....	1	170	1187961	Drive Pin, 5/32 x 1.....	1
42	1769877	Lower Brake Rod.....	1	171	1730851	Clevis Pin, 1/2 x 1-1/4.....	1
43	1702646	Washer, Flat 1/2.....	3	172	1724491	Screw, 5/16-18 x 3/4.....	2
44	1770361	Interlock Latch.....	1	177	1740496	Flange Screw, 5/16-18 x 3/4.....	2
48	1725264	Swivel Block.....	2	302	1915752	Frame Weldment Ass'y (Incl. Ref. 7) (A) (B).....	1
49	1186258	Jam Nut, 5/16-18.....	2	303	1768180	Wheel Rim.....	2
50	1185388	Retaining Ring.....	2	304	1774129	Tire.....	2
51	1708012	Flat Washer.....	4	305	1718086	Valve Stem.....	2
53	1701447	Special Washer.....	A/R	400	GW-97092	Loctite 242, 0.02 oz. Tube.....	N/I
54	1769781	Square Key, 3/16 x 2-1/2.....	2	401	1900706	Red Spray Paint Can, 13 oz. ....	N/I
55	•	Transmission Assembly, Model 915-027 (See page 10 for breakdown.).....	1	402	GW-9532	Clip Ring.....	1
56	1104436	Woodruff Key, 3/16 x 3/4.....	1	403	GW-20546	Washer.....	2

\* Order parts from your local authorized engine dealer. Refer to engine for model/type number.

• Order parts from your local Peerless - Tecumseh dealer.

A/R As required.

N/I Item not included with unit; order separately.

(A) Model 753B

(B) Model E753B

# Wide-Cut Combination Mower

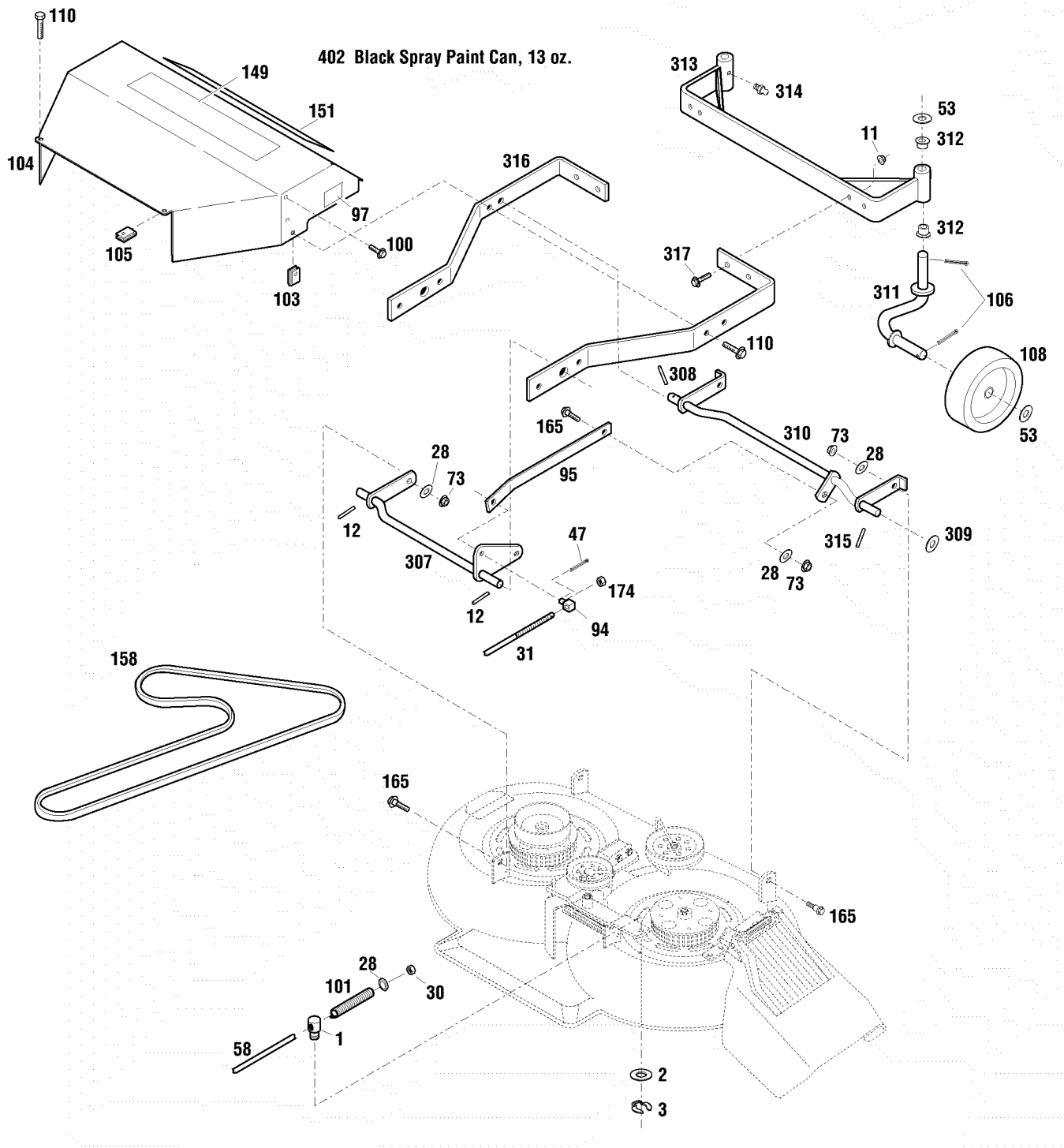

SEE PAGES 8 AND 9  
FOR MOWER DECK ASSEMBLY BREAKDOWN.

## FRONT FRAME ASSEMBLY



# Wide-Cut Combination Mower

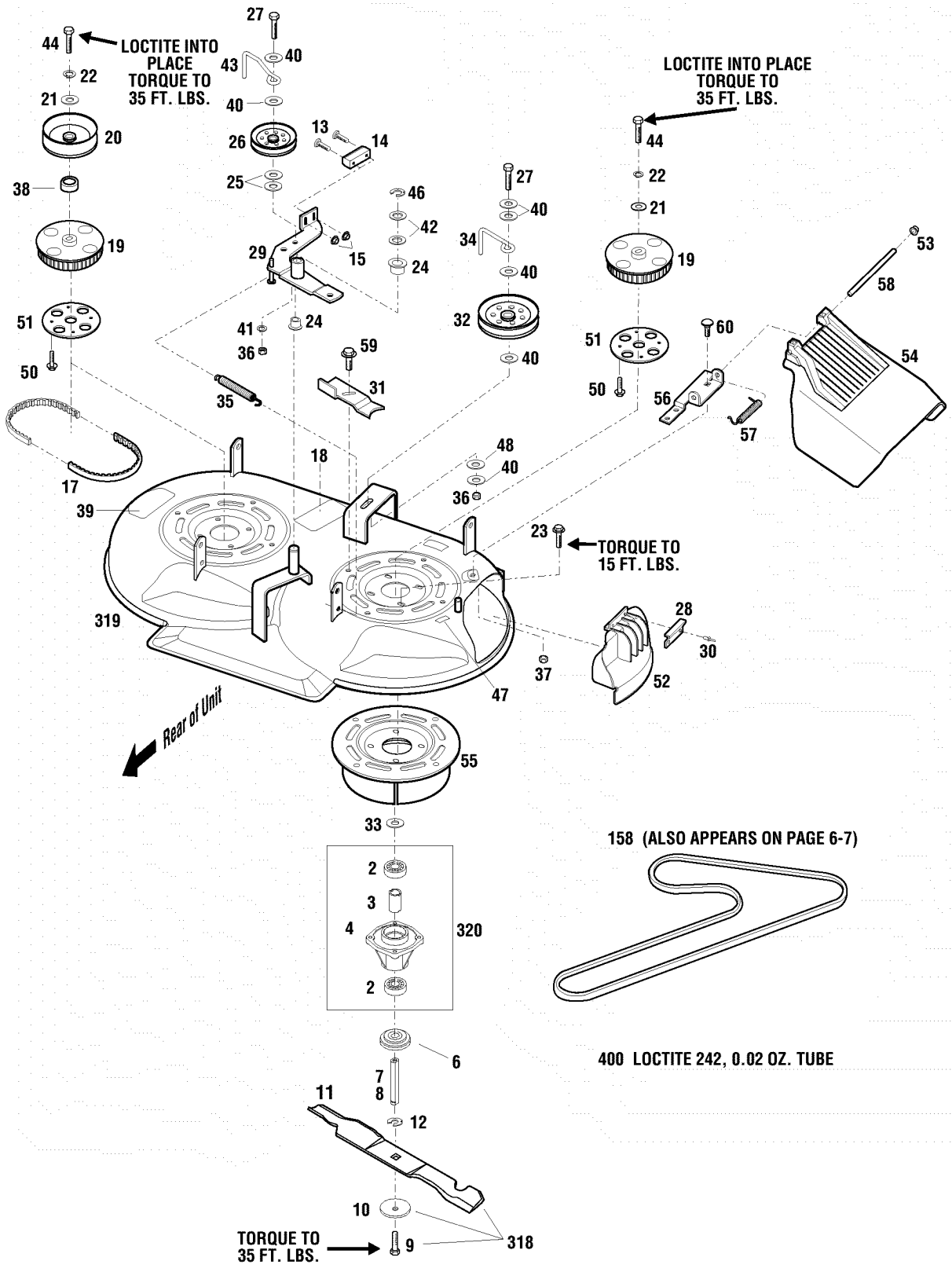

## MOWER DECK ASSEMBLY

Ref.	Part	Description	Qty.	Ref.	Part	Description	Qty.
2	1185574	Ball Bearing .....	4	37	1732499	Locknut, 5/16-18.....	1
3	1746869	Spacer .....	2	38	1723996	Pulley Spacer .....	1
4	1765092	Mower Spindle .....	2	39	777S30118	Danger Decal.....	1
5		Ref. No. not used .....		40	1768818	Flat Washer, 3/8 x 3/4 .....	7
6	1765029	Blade Spacer .....	2	41	736-0169	Lock Washer, 3/8 .....	1
7	1766061	Right Spindle Shaft .....	1	42	1701447	Flat Washer .....	2
8	1768169	Left Spindle Shaft (long) .....	1	43	1764135	Belt Guide.....	1
9	1765196	Screw, 7/16-14 x 1 .....	2	44	1769397	Screw, 7/16-14 x 1-1/4 .....	2
10	1765197	Belleville Washer .....	2	46	716-0101	Retaining Ring.....	1
11	1910917	Blade, 33" Mulching.....	2	47	777S00008	Warning Decal.....	1
12	1185649	Retaining Ring.....	2	48	1185715	Pyramid Washer, 3/8.....	1
13	1771081	Flat Head Screw, #10-24 x 1-1/4.....	2	50	1771925	Triplask Screw, 1/4-20 x 5/8 .....	8
14	1771083	Brake Pad.....	1	51	1771922001	Sprocket Plate .....	2
15	1185985	Nylon Locknut, #10-24 .....	2	52	1773642	Mulcher Cover, Fold-Up Style (Incl. Ref. 28 and 30) .....	1
17	1773600	Toothed Drive Belt .....	1	53	1727342	Cap.....	2
18	777S00004	Caution Decal .....	1	54	1910931	Discharge Chute .....	1
19	1774220	Cogged Pulley, 56T .....	2	55	1910948001	Weldment Doubler .....	2
20	1769362	Drive Pulley .....	1	56	1910951001	Bracket, Chute Hinge.....	1
21	1736484	Flat Washer, 7/16 .....	2	57	1910971	Spring, Discharge Chute.....	1
22	736-0171	Lock Washer, 7/16 .....	2	58	1910972	Pin, Discharge Chute.....	1
23	1773523	Flange Lock Screw, 5/16-18 x 1 .....	8	59	1740496	Screw, Thread-Forming.....	8
24	1764140	Flange Bushing.....	2	60	GW-90077	Bolt, Carriage, 3/8-18 x 3/4 .....	1
25	1701055	Flat Washer .....	2	158	1769767	V-Belt .....	1
26	1762794	Idler Pulley .....	1	318	1773595	Mulching Blade Kit (Incl. Refs. 9, 10 and 11).....	1
27	1100062	Hex Head Capscrew, 3/8-16 x 2-1/2.....	2	319	1773587	Mower Deck Assembly (Incl. Refs. 18, 39 & 47) (A) (B).....	1
28	1911054	Adapter Trim .....	1	320	1769048	Mower Spindle Assembly (Incl. Refs. 2, 3, 4 & 5).....	2
29	1918371	Idler Arm .....	1	400	GW-97092	Loctite 242, 0.02 oz. Tube.....	N/I
30	1186059	Pop Rivet .....	2	401	1735222	Black Spray Paint Can, 13 oz. ....	N/I
31	1911021001	Belt Tension Adjustment Bracket .....	1				
32	1749911	Idler Pulley .....	1				
33	1766787	Special Thrust Washer .....	2				
34	1720717	Belt Guide.....	1				
35	1756595	Extension Spring .....	1				
36	1186231	Nut, 3/8-16.....	2				

N/I Item not included with unit; order separately.

- (A) Model 753B
- (B) Model E753B

# Peerless Transaxle

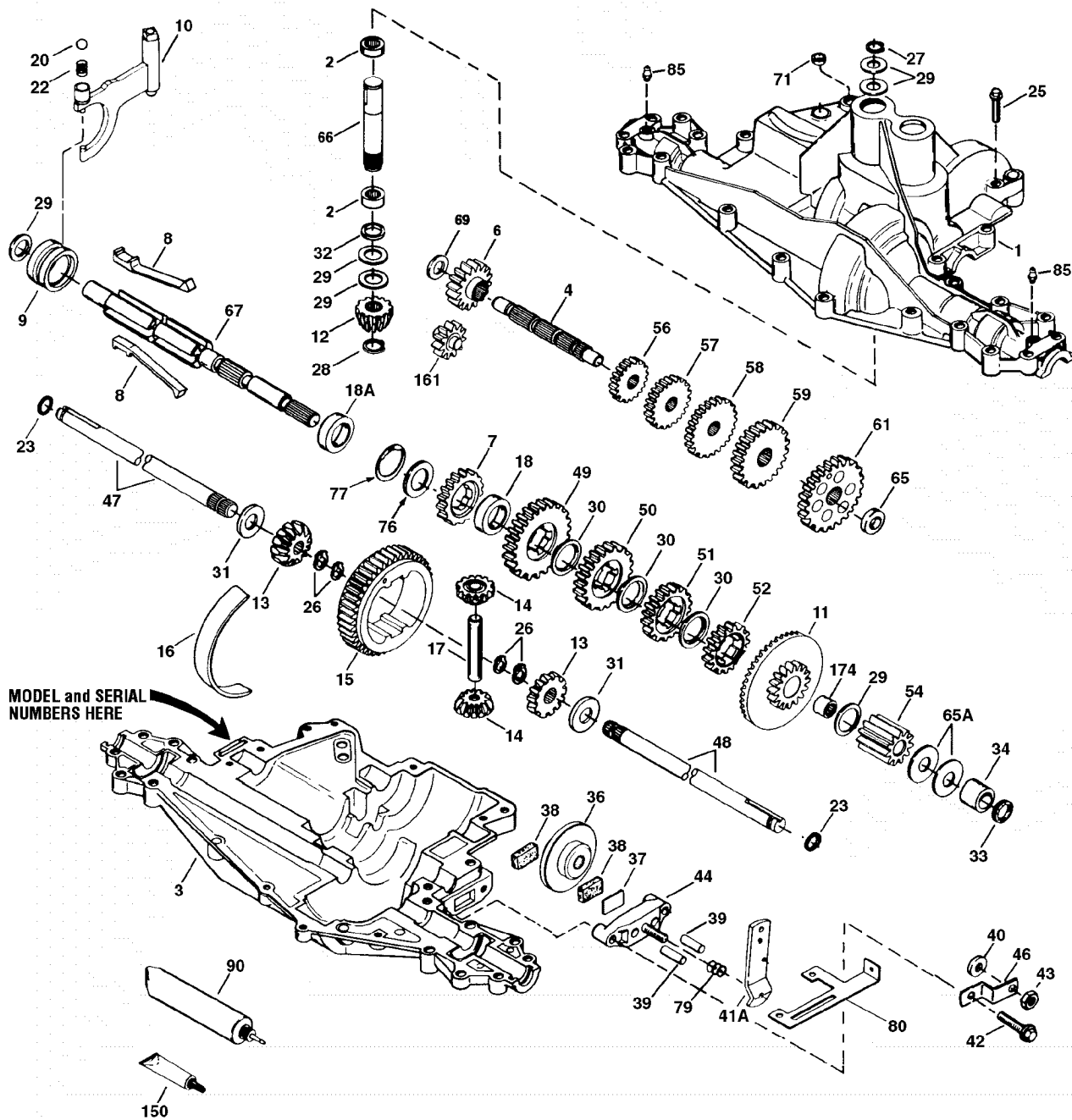

## TRANSAXLE ASSEMBLY

Ref.	Part	Description	Qty.	Ref.	Part	Description	Qty.
1	772113	Transaxle Cover .....	1	39	786026	Dowel Pin .....	2
1	772135	Transaxle Cover .....	1	40	792076A	Washer .....	1
2	780086	Needle Bearing .....	2	41	790045	Brake Lever .....	1
3	770110	Transaxle Case .....	1	42	792073	Screw, 1/4-20 x 1-1/4" .....	2
4	776300	Countershaft .....	1	43	792075	Locknut, 5/16-24 .....	1
6	778281	Spur Gear (16 teeth) .....	1	44	790025	Brake Pad Holder .....	1
7	778122A	Spur Gear (22 teeth) .....	1	46	786086	Brake Lever Bracket .....	1
8	792160	Shift Key .....	4	47	774747	Axle (16-1/4" long) .....	1
9	784373	Shift Collar .....	1	48	774888	Axle (11" long) .....	1
10	784365	Shift Rod & Fork .....	1	49	778124A	Spur Gear (30 teeth) .....	1
11	778261	Bevel Gear & Bearing (Incl. 174) .....	1	50	778123A	Spur Gear (25 teeth) .....	1
12	778262	Bevel Pinion (14 teeth) .....	1	51	778122A	Spur Gear (22 teeth) .....	1
13	778221	Bevel Gear (16 teeth) .....	2	52	778273	Spur Gear (19 teeth) .....	1
14	778068	Differential Pinion .....	2	54	778263	Spur Gear (11 teeth) .....	1
15	778260	Ring Gear .....	1	56	778126A	Spur Gear (20 teeth) .....	1
16	786150	Bearing Strip .....	1	57	778127A	Spur Gear (25 teeth) .....	1
17	786139	Drive Pin .....	1	58	778128A	Spur Gear (28 teeth) .....	1
18	786147	Neutral Spacer .....	1	59	778129A	Spur Gear (30 teeth) .....	1
18A	786159	Neutral Spacer .....	1	61	778265	Spur Gear (34 teeth) .....	1
20	792077	Ball, 5/16" dia. ....	1	65	780162	Washer .....	1
22	792079	Spring .....	1	65A	780160	Washer .....	2
23	788061	Seal Ring .....	2	66	776299	Input Shaft .....	1
25	792073	Screw, 1/4-20 x 1-1/4" .....	17	67	776352	Shifter & Brake Shaft .....	1
26	792125	Retaining Ring .....	4	69	780161	Washer .....	1
27	792035	Retaining Ring .....	1	71	788069	Square Cut Ring .....	1
28	788040	Retaining Ring .....	1	76	780090	Washer .....	1
29	780072	Washer .....	6	77	788078A	Inverted Retaining Ring (pkg. of 2) ..	1
30	780108	Washer .....	3	79	792144	Spring .....	1
31	780001	Washer .....	2	80	790063A	Brake Bracket .....	1
32	792001	"O" Ring .....	1	85	792137	Lubrication Fitting .....	2
33	788076	"O" Ring .....	1	90	788067B	Grease (32 oz. bottle Bentonite grease) ..	1
34	780159	Bushing .....	1	150	510334	Gasket Eliminator (Loctite #515) .....	1
36	790071	Brake Disk .....	1	161	776302	Reverse Idler .....	1
37	790007	Brake Pad Plate .....	1	174	780085	Needle Bearing .....	1
38	799021	Brake Pad (pkg. of 2) .....	2				

**ORDER ALL TRANSAXLE PARTS FROM YOUR LOCAL PEERLESS-TECUMSEH DEALER**

# MANUFACTURER'S LIMITED WARRANTY FOR:



The limited warranty set forth below is given by Troy-Bilt LLC with respect to new merchandise purchased and used in the United States, its possessions and territories.

Troy-Bilt LLC warrants this product against defects for a period of two (2) years commencing on the date of original purchase and will, at its option, repair or replace, free of charge, any part found to be defective in materials or workmanship. This limited warranty shall only apply if this product has been operated and maintained in accordance with the Operator's Manual furnished with the product, and has not been subject to misuse, abuse, commercial use, neglect, accident, improper maintenance, alteration, vandalism, theft, fire, water, or damage because of other peril or natural disaster. Damage resulting from the installation or use of any accessory or attachment not approved by Troy-Bilt LLC for use with the product(s) covered by this manual will void your warranty as to any resulting damage.

Normal wear parts or components thereof are subject to separate terms as follows: All normal wear parts or component failures will be covered on the product for a period of 90 days regardless of cause. After 90 days, but within the two year period, normal wear part failures will be covered ONLY IF caused by defects in materials or workmanship of OTHER component parts. Normal wear parts and components include, but are not limited to: batteries, belts, blades, blade adapters, grass bags, rider deck wheels, seats, snow thrower skid shoes, shave plates, auger spiral rubber, tires.

**HOW TO OBTAIN SERVICE:** Warranty service is available, WITH PROOF OF PURCHASE, through your local authorized service dealer. To locate the dealer in your area, check your Yellow Pages, or contact Troy-Bilt LLC at P.O. Box 361131, Cleveland, Ohio 44136-0019, 1-866-840-6483, or log on to our Web site at [www.troybilt.com](http://www.troybilt.com).

This limited warranty does not provide coverage in the following cases:

- a. The engine or component parts thereof. These items carry a separate manufacturer's warranty. Refer to the applicable manufacturer's warranty for terms and conditions.
- b. Log splitter pumps, valves, and cylinders have a separate one year warranty.
- c. Routine maintenance items such as lubricants, filters, blade sharpening, tune-ups, brake adjustments, clutch adjustments, deck adjustments, and normal deterioration of the exterior finish due to use or exposure.

- d. Troy-Bilt LLC does not extend any warranty for products sold or exported outside of the United States, its possessions and territories, except those sold through Troy-Bilt LLC's authorized channels of export distribution.
- e. Parts that are not genuine Troy-Bilt parts are not covered by this warranty.
- f. Service completed by someone other than an authorized service dealer is not covered by this warranty.
- g. Transportation charges and service calls are not covered.

**No implied warranty, including any implied warranty of merchantability of fitness for a particular purpose, applies after the applicable period of express written warranty above as to the parts as identified. No other express warranty, whether written or oral, except as mentioned above, given by any person or entity, including a dealer or retailer, with respect to any product, shall bind Troy-Bilt LLC. During the period of the warranty, the exclusive remedy is repair or replacement of the product as set forth above.**

**The provisions as set forth in this warranty provide the sole and exclusive remedy arising from the sale. Troy-Bilt LLC shall not be liable for incidental or consequential loss or damage including, without limitation, expenses incurred for substitute or replacement lawn care services or for rental expenses to temporarily replace a warranted product.**

Some states do not allow the exclusion or limitation of incidental or consequential damages, or limitations on how long an implied warranty lasts, so the above exclusions or limitations may not apply to you.

In no event shall recovery of any kind be greater than the amount of the purchase price of the product sold. **Alteration of the safety features of the product shall void this warranty.** You assume the risk and liability for loss, damage, or injury to you and your property and/or to others and their property arising out of the misuse or inability to use the product.

This limited warranty shall not extend to anyone other than the original purchaser or to the person for whom it was purchased as a gift.

**HOW STATE LAW RELATES TO THIS WARRANTY: This limited warranty gives you specific legal rights, and you may also have other rights which vary from state to state.**

**TROY-BILT LLC, P.O. BOX 361131, CLEVELAND, OHIO 44136-0019, 1-866-840-6483**