

Section 4 - ADJUSTMENTS & REPAIR

4.2.1. MOWER DECK ADJUSTMENT (LEVELNESS) (Continued)

6. Loosen the nuts and bolts that secure both front and rear deck support brackets on the high side of deck. Located above each support bracket, on the top part of the power unit frame, are three shim plates. Remove the shim plates on both of the front and rear lift arms and position plates between the support bracket and the frame of the power unit. Inserting the shim plates in this procedure will lower that side of the deck. Retighten the support bracket nuts and bolts to 20 to 30 ft. lbs. of torque. See Figure 4.2.

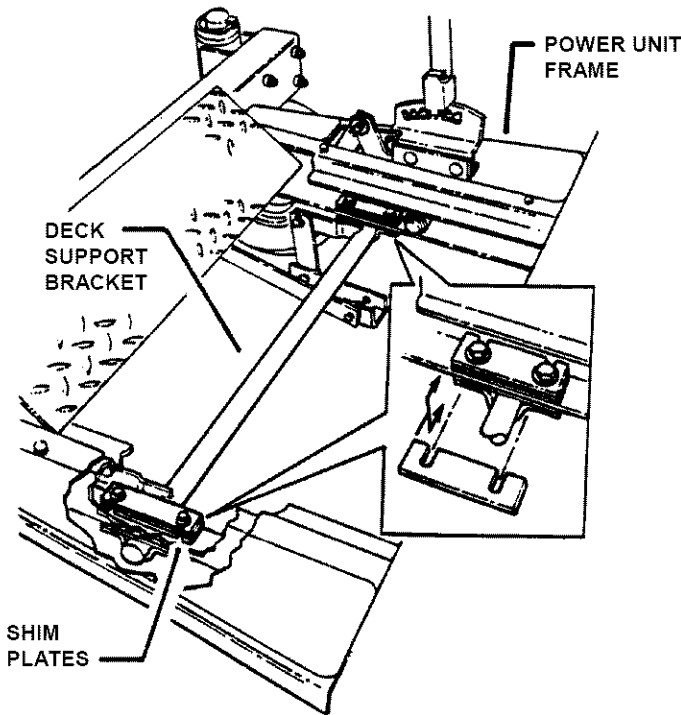

FIGURE 4.2

7. Move deck lift lever and set the mower deck to the highest cutting position and recheck side to side blade tip dimensions. If both blade tips are within 1/8" of each other then levelness is correct. If blade tips are still unlevel repeat steps 1 through 6 and add another shim plate until deck is level.

FRONT to REAR LEVEL

8. Place machine on a smooth level surface.
9. Check blade tips by rotating the outside blades until tips are pointing to the front and rear of deck. Check the measurement of blade tips to the ground on both blades. Front to rear measurement should be 1/4" to 3/8" higher in the rear. If measurement of the blade tips are not within the previously mentioned measurement, adjustment should be made.

10. Move deck lift lever and set the mower deck to the highest cutting position.

11. Place a wooden block under the front and rear edge of the mower deck.

12. Move deck lift lever and set the mower deck to a lower cutting position until deck rests on wooden blocks. This will relieve pressure from deck lift components.

13. **NOTE:** The timing rod connects the front and rear lift arms and maintains the deck in the same attitude through all heights of cut. Adjust the deck by loosening and rotating the timing rod adjusting nuts. Rotate both nuts forward to lower the rear of the deck or rearward to raise the rear of the deck. Tighten the nuts securely. See Figure 10.

14. Raise cutting deck to highest cutting position and check measurement. If blade tips are not within correct measurement repeat steps 8 through 13 until deck is level.

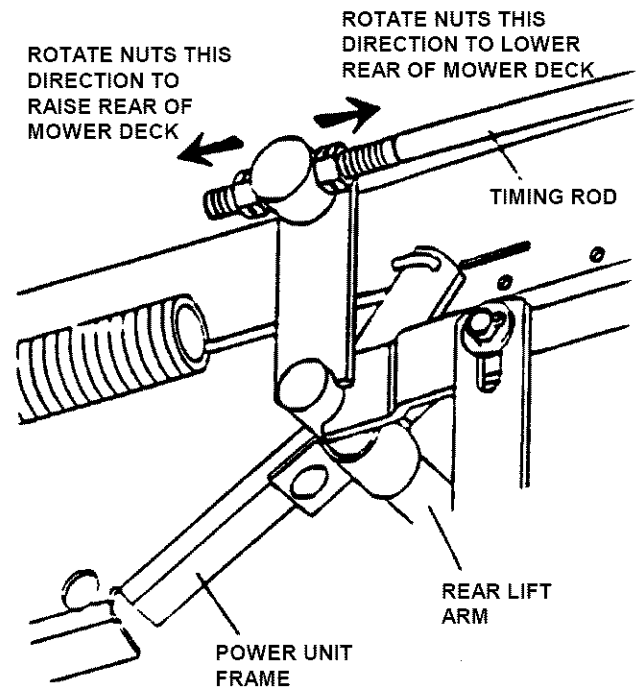

FIGURE 4.2A

SNAPPER®

2 YEAR LIMITED WARRANTY

For two (2) years from purchase date for the original purchaser's use, **SNAPPER**, through any authorized **SNAPPER** dealer will replace, free of charge (except for taxes where applicable), any part or parts found upon examination by the factory at McDonough, Georgia, to be defective in material or workmanship or both.

SNAPPER FIELD SERVICEABLE SPINDLES and their components used on **SNAPPER PRO®** Mid Size walks and **SNAPPERZRIDER®** ride on commercial equipment have a three (3) year limited warranty against defects in material or workmanship or both.

All transportation costs incurred by the purchaser in submitting material to an authorized **SNAPPER** dealer for replacement under this warranty must be paid by the purchaser.

This warranty does not apply to engines and their components, and batteries, as these items are warranted separately. This warranty does not apply to parts that have been damaged by accident, alteration, abuse, improper lubrication, normal wear, or other cause beyond the control of **SNAPPER**. This warranty does not cover any machine or component that has been altered or modified, changing safety, performance, or durability.

Batteries have a one (1) year prorated warranty period with free replacement if required during the first ninety (90) days from the original purchase date. **SNAPPER** will not be responsible for any installation cost incurred. The battery warranty only covers original equipment batteries and does not cover damage to the battery or machine caused by neglect or abuse, destruction by fire, explosion, freezing, overcharging, improper maintenance, or use of improper electrolyte.

There is no other express warranty.

DISCLAIMER OF WARRANTY

Implied warranties, including those of merchantability and fitness for a particular purpose, are limited to two (2) years from purchase date for the original purchaser's use, and up to the extent permitted by law and all implied warranties are excluded. This is the exclusive remedy. Liabilities for consequential damages, under any and all warranties are excluded.

Some states do not allow limitations on how long an implied warranty lasts, or do not allow the exclusion or limitation of incidental or consequential damages, so the above limitation or exclusion may not apply to you.

This warranty gives you specific legal rights, and you may also have other rights which vary from state to state.

WARNING: THE USE OF REPLACEMENT PARTS OTHER THAN GENUINE SNAPPER PARTS MAY IMPAIR THE SAFETY OF SNAPPER PRODUCTS AND WILL VOID ANY LIABILITY AND WARRANTY BY SNAPPER ASSOCIATED WITH THE USE OF SUCH PARTS.

IMPORTANT: Please fill out the attached **SNAPPER** Product Registration Card immediately and mail to:
Snapper's Product Registration Center, P.O. Box 1379, McDonough, Georgia. 30253

Safety Instructions & Operator's Manual for

SNAPPER®

MID MOUNT Z-RIDER

ZERO TURNING

HYDRO DRIVE

SERIES 0

IMPORTANT

Snapper products are built using engines that meet or exceed all applicable emissions requirements on the date manufactured. The labels on those engines contain very important emissions information and critical safety warnings. Read, Understand, and Follow all warnings and instructions in this manual, the engine manual, and on the machine, engine and attachments. If you have any questions about your Snapper product, contact your local authorized Snapper dealer or contact Snapper Customer Service at Snapper, McDonough, GA. 30253. Phone: (1-800-935-2967).

⚠ WARNING: The engine exhaust from this product contains chemicals known to the State of California to cause cancer, birth defects or other reproductive harm.

SNAPPER® McDonough, GA., 30253 U.S.A.