

# Installation Instructions

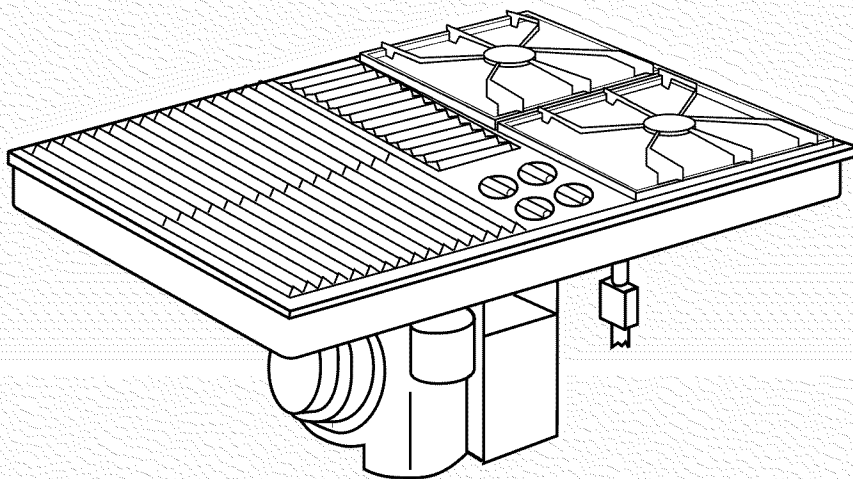

## 30" **GAS** Downdraft Cooktop

Modules selected at time of purchase.

### Quick Reference

#### Table of Contents:

Pages	<b>1</b>	Before you start
	<b>1</b>	Cutout dimensions
	<b>1</b>	Clearance dimensions
	<b>2</b>	Product dimensions
	<b>2</b>	Tools and materials needed
	<b>2</b>	Parts supplied
	<b>2</b>	Electrical requirements
	<b>3</b>	Gas supply requirements
<b>3</b>	<b>4</b>	Venting requirements
<b>5</b>	<b>6</b>	Installation steps
	<b>7</b>	Gas conversions
<b>Back cover</b>		Cooktop removal
<b>Back cover</b>		Wiring diagram

### Need assistance?

Check your Use and Care Guide for a toll-free number to call, or call the dealer from whom you purchased the cooktop when you:

- Have questions about the cooktop installation or operation.
- Need to obtain the name and number of an authorized service company.

The dealer is listed in the Yellow Pages of your phone directory under "Appliances — Household — Major — Service and Repair."

When you call, you will need:

- The cooktop model number.
- The cooktop serial number.

Both numbers are listed on the model/serial rating plate, located on the bottom of the right side of the downdraft plenum.

Write both numbers down now before installing cooktop.

Model # \_\_\_\_\_ Serial # \_\_\_\_\_

**IMPORTANT:**  
**Read and save these instructions.**

Part No. 209811A  
4381590

**IMPORTANT:**

**Installer:** Leave Installation Instructions with the homeowner.  
**Homeowner:** Keep Installation Instructions for future reference.  
**Save** Installation Instructions for local electrical inspector's use.

## Before you start...

**Important: Observe all governing codes and ordinances.**

**Proper installation** is your responsibility.

- Make sure you have everything necessary for correct installation.
- **Have a qualified technician install this cooktop.**
- Comply with the installation clearances specified on the model/serial rating plate.

**Model/serial rating plate** is located on the right side of the downdraft plenum.

**Cooktop location** should be away from strong draft areas, such as windows, doors and strong heating vents or fans. Locate cooktop for convenient use in kitchen.

**Grounded electrical outlet** is required. See "Electrical requirements," Page 2.

**Proper gas supply connection** must be available. See "Gas supply requirements," Page 3.

**Venting duct** must terminate outdoors.

**All openings in the wall or floor** where cooktop is to be installed must be sealed.

**WARNING: If the information in this manual is not followed exactly, a fire or explosion may result causing property damage, personal injury or death.**

- **Do NOT store or use gasoline, or other flammable vapors and liquids in the vicinity of this or any other appliance.**
- **WHAT TO DO IF YOU SMELL GAS**
  - **Do NOT try to light any appliance.**
  - **Do NOT touch any electrical switch; Do NOT use any phone in your building.**
  - **Immediately call your gas supplier from a neighbor's phone. Follow the gas supplier's instructions.**
  - **If you cannot reach your gas supplier, call the fire department.**
- **Installation and service must be performed by a qualified installer, service agency or the gas supplier.**

## WARNING



### Electrical Shock Hazard

It is the customer's responsibility to contact a qualified electrical installer, to make sure that the electrical installation is correct, and to make sure the electrical installation follows the National Electrical Code, ANSI/NFPA 70 — latest edition\*, and all local codes and ordinances.

Take special care when cutting holes into a wall. Electrical wires may be behind the wall covering and you could get an electrical shock if you touch them.

Disconnect the power to any electrical circuits that could be affected by the installation of this product.

Failure to do so could result in death or serious injury.

### Injury Hazard

To eliminate the risk of burns or fires, do not install cabinets or store things above the cooktop. If cabinets are already installed above the cooktop, install a range hood to the bottom of the cabinet to prevent reaching over a heated cooking surface. The range hood should stick out a minimum of 5 inches (12.7 cm) from the front of the cabinets.

Reaching over a heated cooking surface could result in a serious burn or other injury.

This appliance is Not approved for use in mobile homes.

Copies of the standards listed may be obtained from:

\* National Fire Protection Association  
Batterymarch Park  
Quincy, Massachusetts 02269

## Cutout dimensions

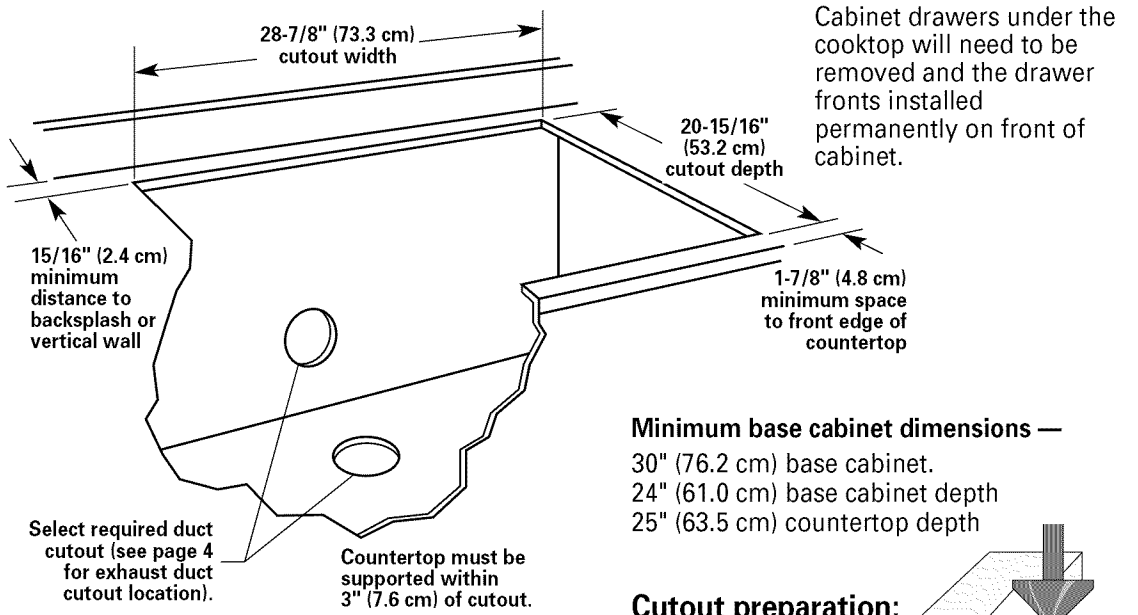

Cabinet drawers under the cooktop will need to be removed and the drawer fronts installed permanently on front of cabinet.

### Minimum base cabinet dimensions —

- 30" (76.2 cm) base cabinet.
- 24" (61.0 cm) base cabinet depth
- 25" (63.5 cm) countertop depth

### Cutout preparation:

Decorative laminate — Chamfer all exposed edges to prevent chipping laminate. Cut radius corners and file to insure smooth edges and to prevent cracking.

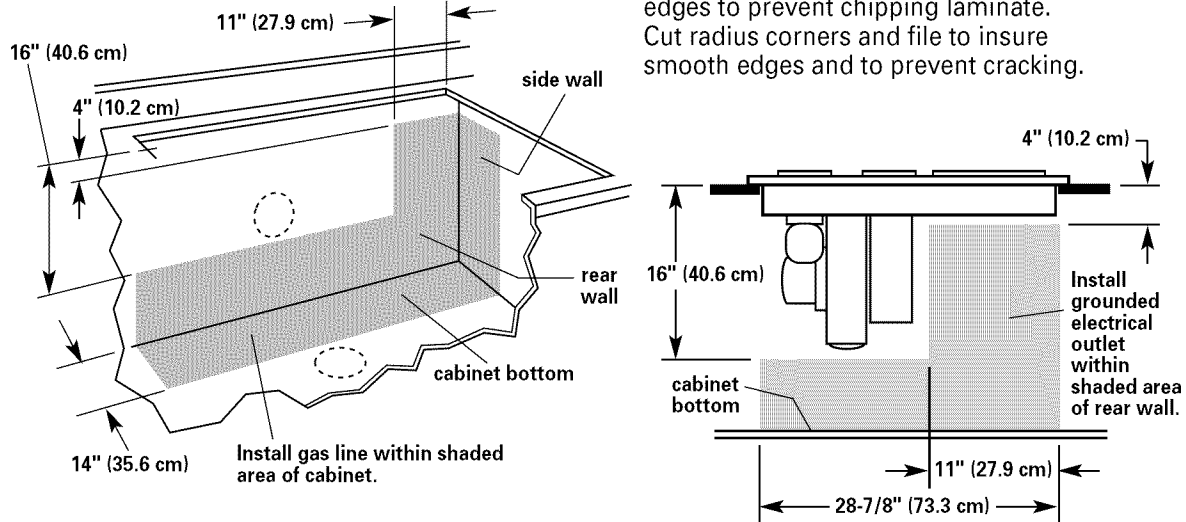
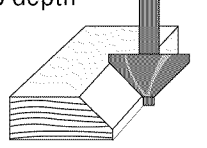

## Clearance dimensions

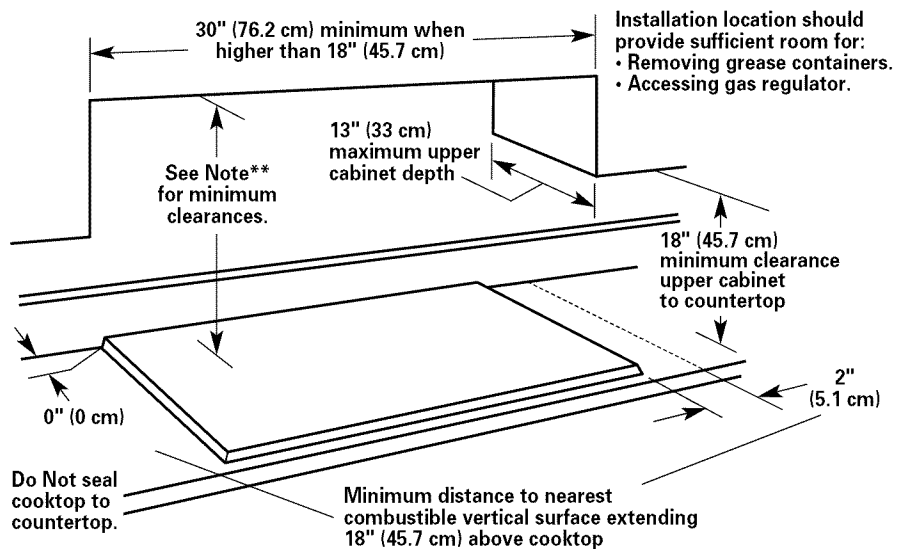

\*\* Note: 30" (76.2 cm) minimum when bottom of wood or metal cabinet is protected by not less than 1/4" flame retardant millboard covered with not less than No. 28 MSG sheet steel, 0.015" stainless steel, 0.024" aluminum or 0.020" copper.

36" (91.4 cm) minimum clearance between the top of the cooking platform and bottom of unprotected wood or sheet metal.

**Side clearance** — 2" (5.1 cm) minimum clearance is required. 6" (15.2 cm) clearance between side of cooktop and side wall is recommended for maximum ventilation performance.

**Rear clearance** — The rear edge of the cooktop may be installed flush with countertop backsplash. 15/16" (2.4 cm) clearance between rear edge of appliance and rear wall is recommended.

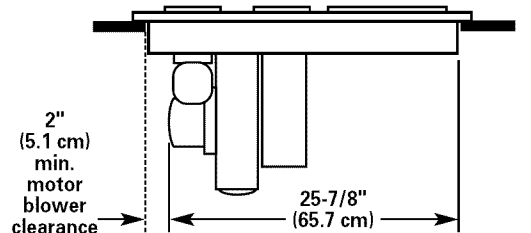

**Motor/blower clearance** — 2" (5.1 cm) clearance is required between motor and cabinet for proper cooling. 6" (15.2 cm) clearance is recommended for maximum performance.

## Spacing for multiple downdraft cooktop installations:

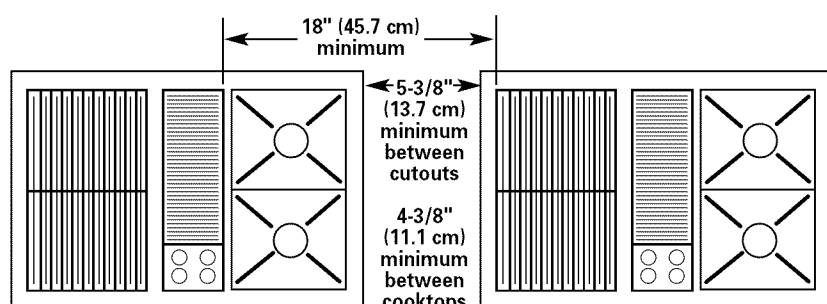

Minimum spacing shown is required for satisfactory performance when installing the

downdraft cooktop in combination with one or more downdraft cooktops.

## Product dimensions

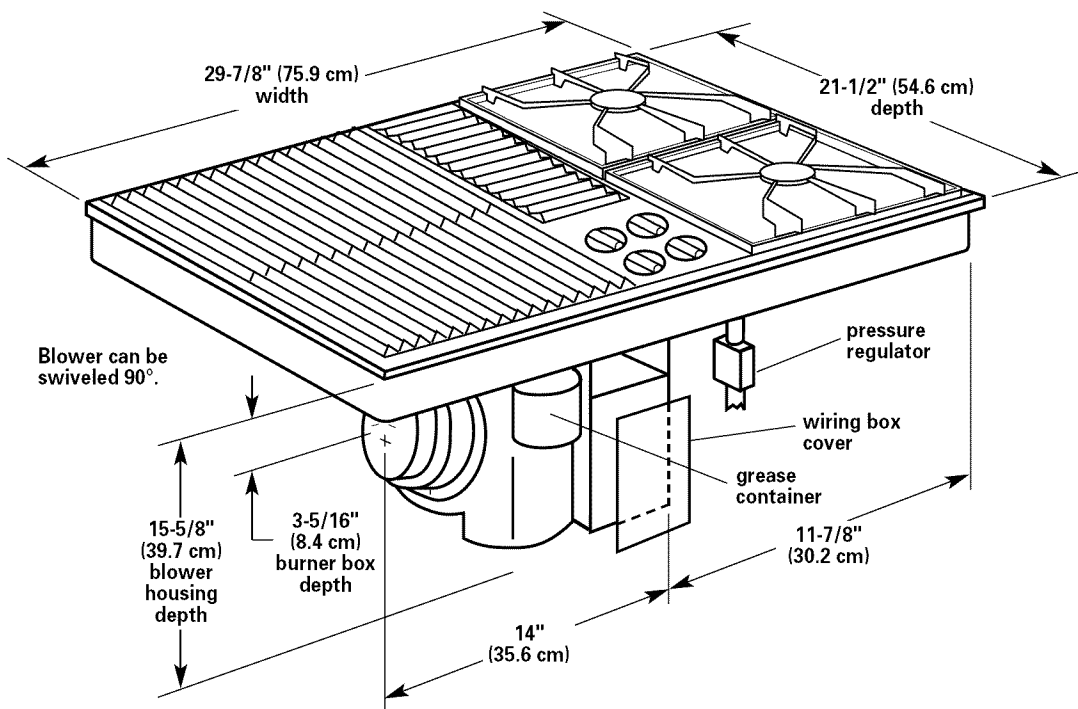

## Tools and materials needed:

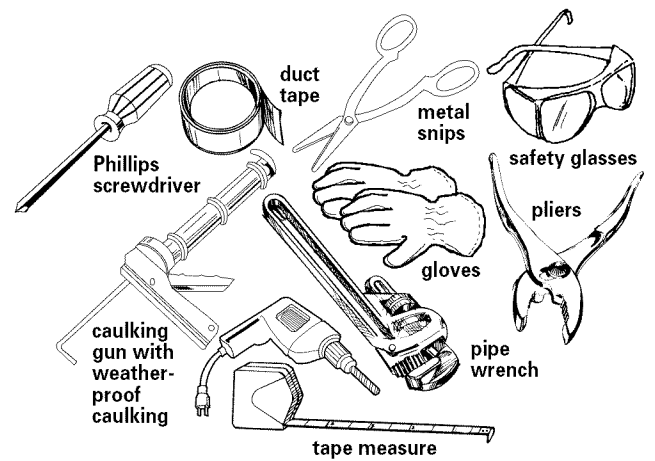

### Not shown:

- gas line shutoff valve
- L.P. gas-resistant pipe-joint compound
- A.G.A. design-certified flexible metal connector (4-5 feet) (1.2-1.5 m) or rigid gas supply line as needed
- flare union adapter for connection to pressure regulator (1/2" NPT x 1/2" or 3/4" I.D.)
- wall or roof cap
- metal ductwork
- 2 sheet metal screws to attach transition duct to venting adapter

## Parts supplied:

Remove parts from packages. Check that all parts were included.

- literature pack
- 4 orifice hoods
- exhaust flow rate tester card

## Electrical requirements

### WARNING



#### Electrical Shock Hazard

Electrical ground is required on this appliance.

Do Not ground to a gas pipe.

Do Not change the power supply cord plug. If the plug will not fit the outlet, have a proper outlet installed by a qualified electrician.

Do Not have a fuse in the neutral or grounding circuit. A fuse in the neutral or grounding circuit could result in an electrical shock.

Do not use an extension cord with this appliance.

Check with a qualified electrician if you are not sure the cooktop is properly grounded.

Failure to follow these instructions could result in death or serious injury.

A 120-volt, 60-Hz, AC-only, 15- or 20-ampere, fused electrical supply is required. A time-delay fuse or circuit breaker is recommended. It is recommended that a separate circuit serving only this appliance be provided.

Electronic ignition systems operate within wide voltage limits, but proper grounding and polarity are necessary. In addition to checking that the outlet provides 120-volt power and is correctly grounded, the outlet must be checked by a qualified electrician to see if it is wired with correct polarity.

The wiring diagram is located on the inside of the terminal box cover.

## Recommended grounding method

For your personal safety, this appliance must be grounded. This appliance is equipped with a power supply cord having a 3-prong grounding plug. To minimize possible shock hazard, the cord must be plugged into a mating 3-prong grounding-type wall receptacle, grounded in accordance with National Electrical Code ANSI/NFPA 70 — latest edition\* and all local codes and ordinances. See Figure 1. If a mating wall receptacle is not available, it is the personal responsibility and obligation of the customer to have a properly grounded, 3-prong wall receptacle installed by a qualified electrician.

Copies of the standards listed above may be obtained from:

\* National Fire Protection Association  
Batterymarch Park  
Quincy, Massachusetts 02269

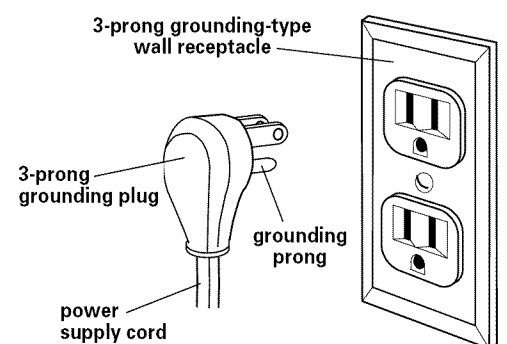

Figure 1

If codes permit and a separate grounding wire is used, it is recommended that a qualified electrician determine that the grounding path is adequate.

# Gas supply requirements

## WARNING



### Fire Hazard

This downdraft cooktop must be connected to a regulated gas supply.

L.P. gas supply must NOT exceed 14-inch water column pressure. This must be checked by a qualified technician before installing this cooktop.

Do Not use an open flame to test for leaks from gas connections.

New A.G.A. design-certified flexible gas line should be used when codes permit.

Failure to follow these instructions could result in an explosion, fire or personal injury.

This installation must conform with all local codes and ordinances. In the absence of local codes, installation must conform with American National Standard, National Fuel Gas Code ANSI Z223.1 — latest edition\*\* and all local codes and ordinances.

Copies of the standards listed above may be obtained from:

\*\* American Gas Association  
1515 Wilson Boulevard  
Arlington, Virginia 22209

Input ratings shown on the model/serial rating plate are for elevations up to 2,000 feet (609.6 m). For elevations above 2,000 feet (609.6 m), a 4 percent reduction of the rating is required for each 1,000 feet (304.8 cm) in elevation. For assistance when installing the cooktop at higher elevations, contact your local service company.

**Type of gas:** This downdraft cooktop is factory set for use with Natural gas. It is design-

certified by the American Gas Association (A.G.A.) for Natural or L.P. gas usage with appropriate conversion. (See "Gas conversion" instructions, Page 7). The model/serial rating plate (located on the right side of the downdraft plenum) lists the type of gas that can be used. If the type of gas listed does not agree with the type of gas available, check with the local gas supplier. **Conversion must be done by a qualified service technician.**

**Gas supply line:** With Natural gas, provide a gas supply line of 3/4" rigid pipe to the downdraft cooktop location. With L.P. gas, piping or tubing can be 1/2" minimum. A smaller size pipe on long runs may result in insufficient gas supply. Usually, L.P. gas suppliers determine the size and materials used on the system.

**Pipe-joint compounds** made for use with L.P. gas must be used.



**Flexible metal appliance connector:** If local codes permit, a new A.G.A. design-certified, 4-5 foot (1.2-1.5 m) long, 1/2" or 3/4" I.D., flexible metal appliance connector is recommended for connecting the cooktop to the gas supply line. A 1/2" male pipe thread is needed for connection to pressure regulator female pipe threads. **Do Not kink or damage the flexible metal tubing when moving the downdraft cooktop.**

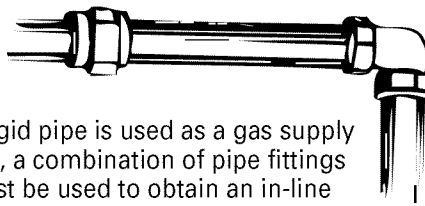

If rigid pipe is used as a gas supply line, a combination of pipe fittings must be used to obtain an in-line connection to the downdraft cooktop. All strains must be removed from the supply and fuel lines so cooktop will be level and in line.

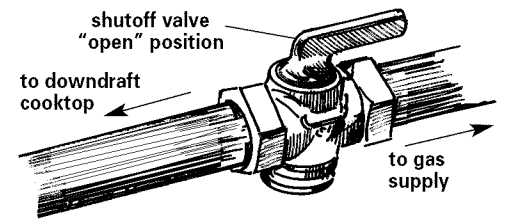

**Shutoff valve:** The supply line must be equipped with an approved manual shutoff valve. This valve should be located in the same room as the downdraft cooktop and should be in a location that allows ease of opening and closing. The valve is for turning on or shutting off gas to the appliance. **Do Not block access to shutoff valve.**

**Pressure regulator:** The gas pressure regulator supplied with this downdraft cooktop must be used. The regulator must be checked at a minimum 1-inch water column above the set pressure. The inlet pressure to the regulator should be as follows for operation and for checking the regulator setting:

### NATURAL GAS:

Minimum pressure: 6 inches WC  
Maximum pressure: 14 inches WC

### L.P. GAS:

Minimum pressure: 11 inches WC  
Maximum pressure: 14 inches WC

### Line pressure testing above 1/2 psi gauge (14" WC)

— The downdraft cooktop and its individual shutoff valve must be disconnected from the gas supply piping system during any pressure testing of that system at test pressures greater than 1/2 psi (3.5 kPa).

### Line pressure testing at 1/2 psi gauge (14" WC) or lower

— The downdraft cooktop must be isolated from the gas supply piping system by closing its individual manual shutoff valve during any pressure testing of that system at test pressures equal to or less than 1/2 psi (3.5 kPa).

# Venting requirements

Duct materials needed for installation are not supplied.

## WARNING



### Fire Hazard

The venting system **MUST** end outdoors.

Do Not end the duct in an attic, wall, ceiling or other enclosed space.

Do Not use 4" laundry-type wall caps.

Do Not use plastic-type duct.

Do Not block the flow of combustion and ventilation air.

Failure to follow these instructions could result in a fire.

Before making cutouts, make sure there is proper clearance within the wall or floor for the exhaust duct.

Do Not cut a joist or stud unless absolutely necessary. If a joist or stud must be cut, then a supporting frame must be constructed.

Determine which venting method to use. See "Venting methods," Page 4.

Next, determine the equivalent duct length using the chart on page 4. This cooktop is equipped with a dual range blower. The equivalent duct length (not actual) determines whether blower is set at the "Low" or "High" range. The blower is set at the "Low" range setting at the factory.

**The blower housing** must be rotated or swiveled to the proper angle needed for your installation. The blower can be swiveled 90°. The blower may be rotated horizontally or vertically. Reach through the ventilation chamber to loosen, but Do Not remove, the nuts around the blower inlet to adjust blower. **This downdraft cooktop is rated at 60 feet (18.3 m) of straight duct.**

- If duct length is 10 feet (3 m) or less, 5" diameter round duct **MUST** be used.
- If duct length is more than 10 feet (3 m), use 6" diameter round or 3-1/4" x 10" rectangular duct.

**Thermal breaks:** In areas of extreme cold weather, it may be necessary to provide a short length of nonmetallic duct as close to the wall as possible to prevent thermal conduction along the metal duct.

**For altitudes above 4,500 ft (1,350 m),** reduce recommended duct run by 20%.

## For the most efficient and quietest operation:

- Use 26-gauge minimum galvanized or 25-gauge minimum aluminum metal duct. Poor-quality pipe fittings can reduce air flow. (Note: Local codes may require a heavier-gauge material.) Flexible metal duct is not recommended.
- Do Not exhaust more than one downdraft cooktop into a single duct system.
- The length of duct and number of elbows should be kept to a minimum to provide efficient performance.
- The size of the duct should be uniform.
- Use no more than three 90° elbows.
- Do Not install two elbows together.
- Make sure there is a minimum of 18" (46 cm) of straight duct between the elbows if more than one elbow is used. (Elbows too close together cause excess turbulence that reduces airflow.)
- Do Not use a 5" elbow in a 6" or 3-1/4" x 10" system. Instead, use a 5" to 6" transition followed by a 6" elbow, or a 5" to 3-1/4" x 10" elbow transition.
- Do Not reduce back to 5" system after using 6" or 3-1/4" x 10" fittings.
- Avoid forming handmade crimps. Handmade crimps may restrict airflow.
- Use the recommended duct caps for proper performance. If an alternate wall or roof cap is used, be certain cap size is not reduced and that it has a backdraft damper.
- Use duct tape to seal all joints in the ductwork system.
- Use caulking to seal exterior wall or roof opening around the cap.

# Venting methods

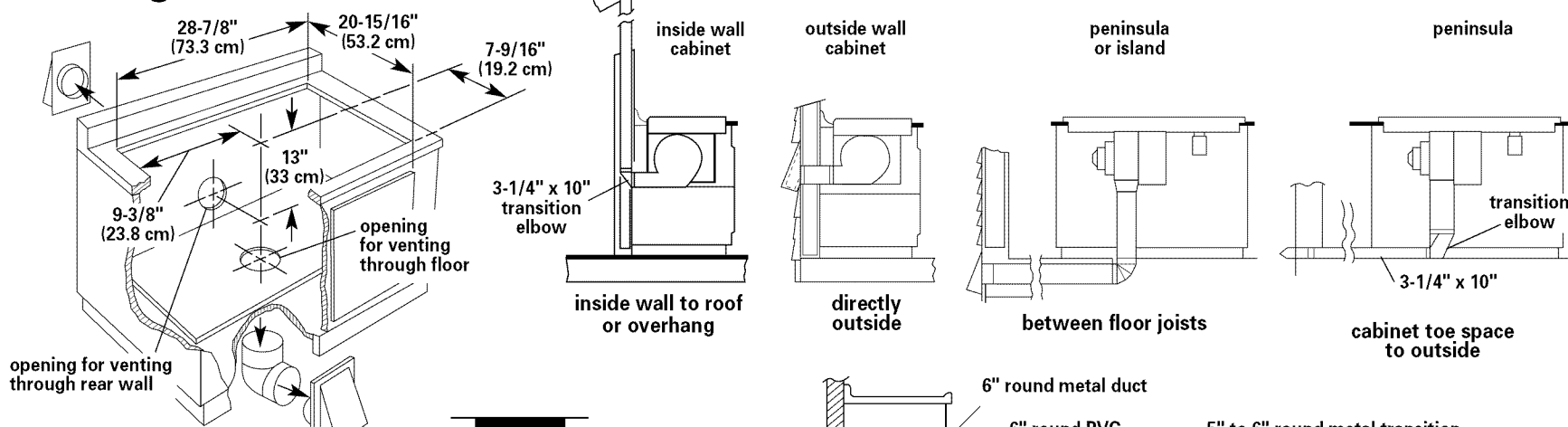

The cooktop may be vented through the rear wall or floor. Common venting methods and the types of materials needed are shown.

Make sure there is proper clearance within the wall or floor for exhaust duct before making cutouts.

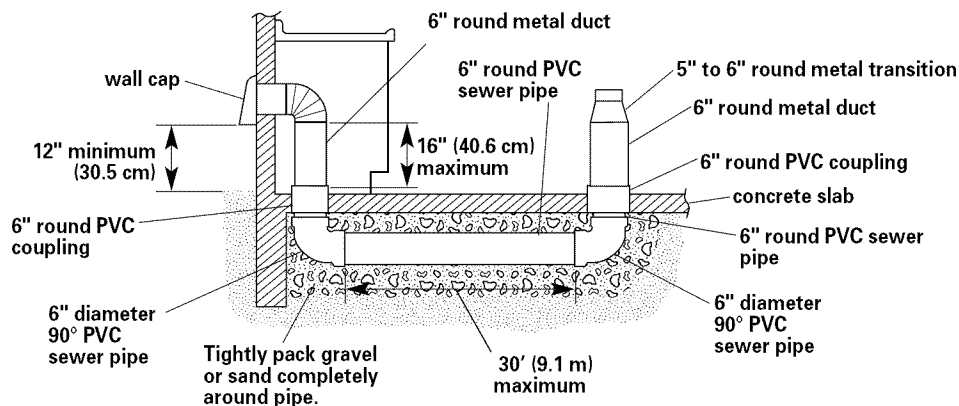

optional duct arrangement under concrete slab

## Determine range blower setting.

This cooktop is equipped with a dual range blower. It is factory set at "Low" range to be used for equivalent duct length runs of 30 feet (9.1m) or shorter. **If the equivalent duct length exceeds 30 feet (9.1m), the blower must be shifted to "High" range. Do Not shift to "High" range for runs shorter than 30 feet (9.1m).** Using the "High" range on shorter runs will cause excessive noise and conditioned air loss, and will affect the flame pattern of gas burners. List the number of each piece and length of straight duct you will use. Multiply the equivalent length by the number of pieces. Add the totals to get the total equivalent length of your system.

Duct Piece	Equivalent Length	No. of Pieces/Length	Total Equivalent Length
<b>straight duct per lineal ft.</b>			
3-1/4" x 10"	1 ft. (30.5 cm)		
6" round	1 ft. (30.5 cm)		
6" flexible	2 ft. (61 cm)		
<b>elbow</b>			
6" round 45° elbow	2.5 ft. (76 cm)		
6" round 90° elbow	5 ft. (152 cm)		
3-1/4" x 10" flat elbow	12 ft. (366 cm)		
3-1/4" x 10" 90° elbow	5 ft. (152 cm)		
<b>transition to round</b>			
5" to 6"	1 ft. (30.5 cm)		
3-1/4" x 10" to 6" 90° elbow	9 ft. (274 cm)		
3-1/4" x 10" to 6"	4.5 ft. (137 cm)		
<b>transition to flat</b>			
5" to 3-1/4" x 10" 90° elbow	6 ft. (183 cm)		
6" to 3-1/4" x 10" 90° elbow	5 ft. (152 cm)		
6" to 3-1/4" x 10"	1 ft. (30.5 cm)		
<b>wall cap*</b>			
3-1/4" x 10"	0 ft. (0 cm)		
5" or 6" round	0 ft. (0 cm)		
<b>roof cap*</b>			
10" x 10"	0 ft. (0 cm)		
<b>thermal break</b>			
5" or 6" round	2 ft. (61 cm)		
<b>Total equivalent duct system length</b>			

\* Length for required wall/roof cap has already been incorporated into rating for maximum duct system length. A suitable wall/roof cap must be used.

## Duct system equivalent length 30 feet or less — blower should be set at "Low" range.

Example:

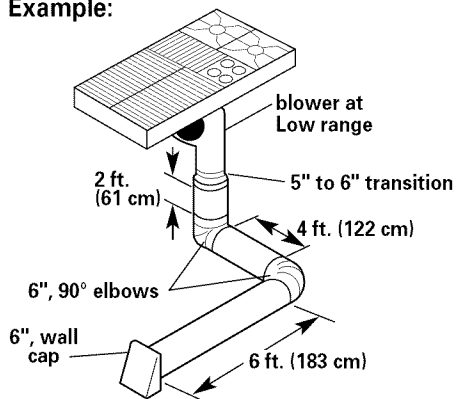

- 90° elbows (2) = 10 ft. (305 cm)
- 12 feet (366 cm) straight = 12 ft. (366 cm)
- 5" to 6" transition = 1 ft. ( 30.5 cm)
- Wall cap = 0 ft. ( 0 cm)

Equivalent length of 6" round system = 23 ft. (701.5 cm)  
(In this example, blower can be left in "Low" range as set at factory.)

## Duct system equivalent length greater than 30 feet — blower should be set at "High" range.

Example:

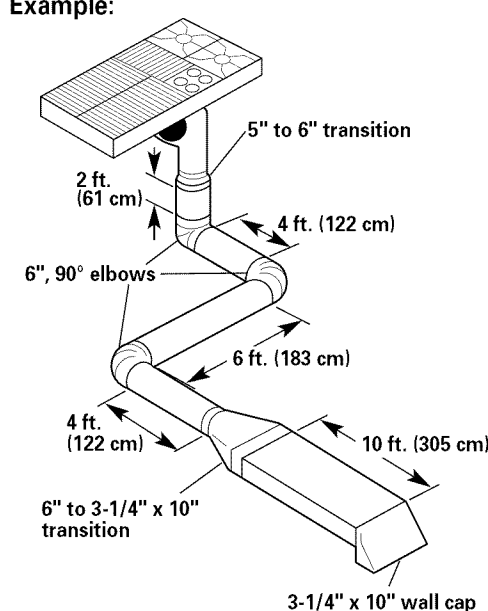

- 90° elbows (3) = 15 ft. ( 457.2 cm)
- 5" to 6" transition = 1 ft. ( 30.5 cm)
- 6" to 3-1/4" x 10" transition = 1 ft. ( 30.5 cm)
- Wall cap = 0 ft. ( 0 cm)
- 16 feet (488 cm) 6" straight = 16 ft. ( 488 cm)
- 10 feet (305 cm) 3-1/4" x 10" straight = 10 ft. ( 305 cm)

Equivalent length of 6" round system = 43 ft. (1311.2 cm)  
(In this example, blower **MUST** be shifted to "High" range.)

### Note: Flexible metal duct is Not recommended.

If it is used, calculate each foot of flexible duct as two feet of straight metal ductwork. Flexible metal elbows count twice as much as standard elbows.

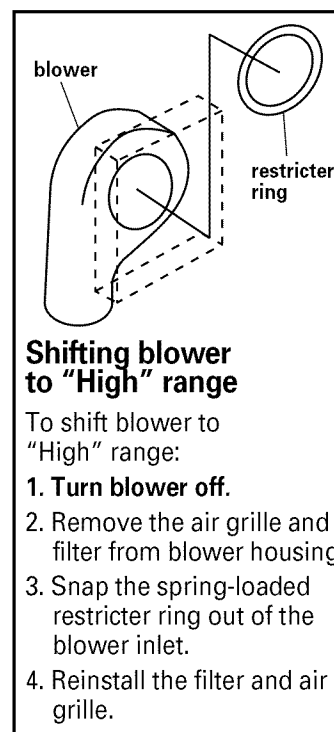

### Shifting blower to "High" range

- To shift blower to "High" range:
1. Turn blower off.
  2. Remove the air grille and filter from blower housing.
  3. Snap the spring-loaded restrictor ring out of the blower inlet.
  4. Reinstall the filter and air grille.

# Installation steps

Note: Cooktop shown with optional grill accessory.

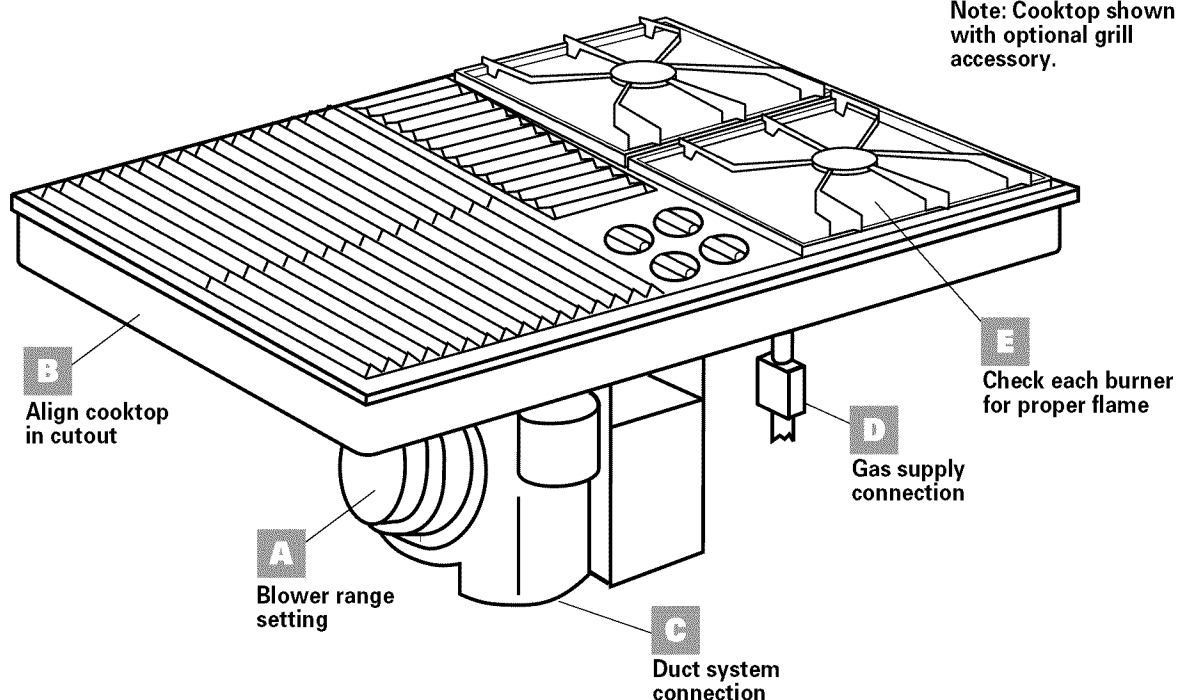

## WARNING

### Injury Hazard

Because of the weight and size of the cooktop, more than one person is required to move, lift and safely install it. Failure to follow these instructions could result in serious injury.

## A Preparation

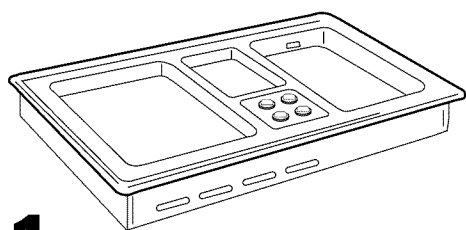

**1.** Remove the downdraft cooktop from packaging.

**2.** Check equivalent duct length to determine if blower should be set at "Low" or "High" range (see chart on page 4 to determine equivalent duct system length). If duct system length is greater than 30 feet (9.1m), shift the blower range setting from "Low" to "High" (see instructions on page 4 for shifting the blower range).

If blower must be shifted to "High" range, do it now.

## B Installation

**3.** Insert downdraft cooktop into cutout. Check that:

- cooktop is centered in cutout.
- front edge of downdraft cooktop is at least 1-1/2" (3.8 cm) from front edge of countertop and parallel to countertop.
- side edge of cooktop is at least 2 inches (5.1 cm) from side wall.

## C Duct connection

**4.** Connect duct system. See "Venting requirements," pages 3-4. Use duct tape to seal all joints. Duct must end with a wall or roof cap outside the building.

## D Gas connection

### WARNING



### Fire Hazard

Do Not make the connection too tight. The regulator is die cast. Making the connection too tight may crack the regulator, resulting in a gas leak and possible explosion or fire.

Do Not use an open flame to test for leaks from gas connections.

Checking for leaks with an open flame may result in a fire or explosion.

All connections must be wrench-tightened.

**5.** Assemble the flexible connector from the gas supply pipe to the pressure regulator in order: manual shutoff valve, 1/2" nipple, 1/2" adapter, flexible connector, 1/2" adapter, 1/2" nipple and pressure regulator. Or install rigid piping as required.

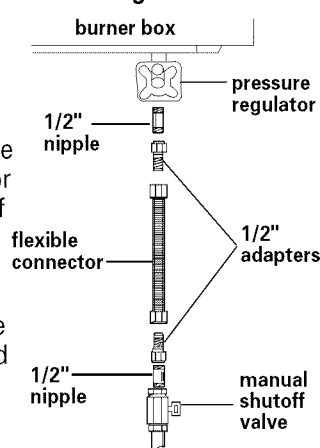

**6.** Use pipe-joint compound made for use with L.P. gas to seal all pipe thread gas connections. If flexible connectors are used, be certain connectors are not kinked.

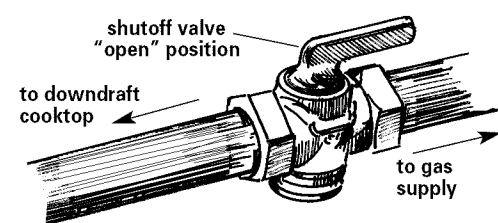

**7.** Open the manual shutoff valve in the gas supply line. Wait a few minutes for the gas to move through the line.

**8.** Use a brush and liquid detergent to test all gas connections. Bubbles around the connections will indicate a leak. If a leak appears, shut off gas valve controls and adjust connections. Then check connections again. NEVER TEST FOR GAS LEAKS WITH A MATCH OR OTHER FLAME. Clean all detergent from the cooktop.

## E Check operation

- 9.** Plug the power supply cord into the grounded outlet.

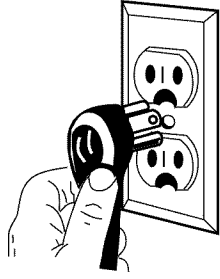

### flow tester

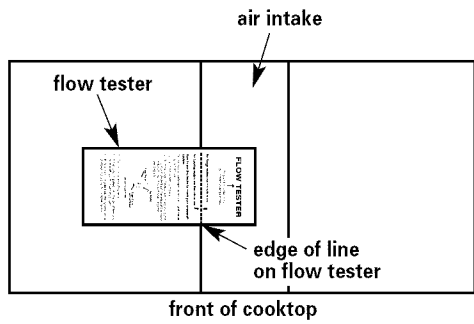

- 10.** Check for proper venting:

- Check that the air filter is in place.
- Align the dotted line labeled for “cooktop models” on the flow tester with the edge of the intake on the left side of the cooktop near the center.
- Turn on the downdraft system:  
**If the card is pulled into the air intake,** your downdraft is working properly.  
**If the card is not pulled into the system,** see “Venting requirements,” Pages 3-4, and check duct installation for possible causes.

### Electronic ignitions system

Cooktop burners use electronic ignitors in place of standing pilots. When the cooktop control knob is turned to the “LITE” position, the system creates a spark to light the burner. This sparking continues until the control knob is turned to the desired setting.

### Check operation of right-side surface burners module

## 11.

Push down and turn each surface burner control knob to “LITE” position. The flame should light within 4 seconds. Turn the control knob to “HI” position after burner lights. **Do Not leave the knob in the “LITE” position after burner lights.**

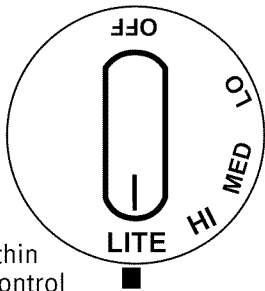

Check each surface burner for proper flame at “HI” setting. The small inner cone should have a very distinct, blue flame that is 1/4" (0.6 cm) to 1/2" long (1.3 cm). The outer cone is not as distinct as the inner cone. Turn surface burner control knobs to “OFF” position.

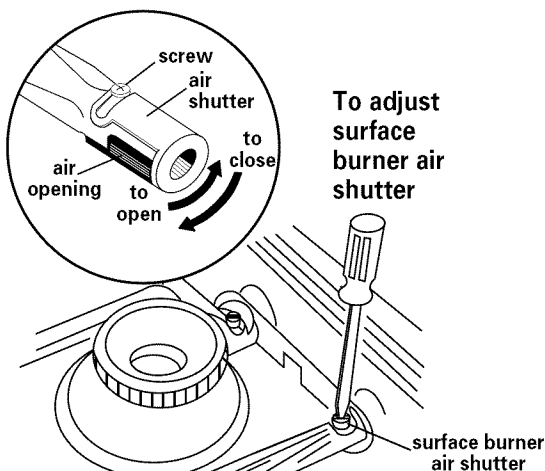

### If surface burner flames need adjusting –

- Remove burner grate and burner pan.
- Turn control knob to “HI” position.
- Loosen the air shutter screw. Adjust the air shutter to the widest opening that will not cause the flame to lift or blow off the burner.
- After adjusting air shutter, tighten air shutter screw.
- Turn control knob to “OFF” position.
- Replace burner grate and burner pan.
- Repeat if necessary for other surface burner.

- 12.** Push in and turn each surface burner control knob to “LITE” position and then to “LO” position. The low flame should be a minimum, steady blue flame.

**Do Not use a metal blade to pry off control knob; this could damage the product. If the control knob cannot be easily removed, tuck a cloth under the knob and pull upward on cloth with steady, even pressure to remove knob.**

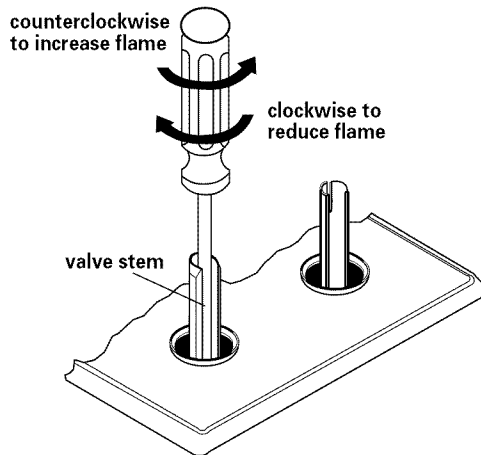

### If the low flame needs adjusting –

- Remove the control knob and turn the adjustment screw in the center of the valve stem. Do Not turn screw more than 1/2 revolution in either direction.
- Replace the control knob. Check the adjustment by turning the control knob from “HI” to “LO” several times. The burner is properly adjusted when the low flame remains steady and the burner does not go out.
- Turn control knob to “OFF” position.
- Repeat if necessary for other surface burner.

### Check operation of left-side surface burners or optional grill module

**13.** Use module instructions to install left-side surface burner or optional grill module.

**Surface burners module:** Push in and turn right surface burner control knob to “LITE” position. The flame should light within 4 seconds. Turn the control knob to “HI” position after burner lights. **Do Not leave the knob in the “LITE” position after burner lights.**

Check surface burner for proper flame. The small inner cone will be similar to the right-side module surface burner flames, but will be shorter and softer. The outer cone is not as distinct as the inner cone. Turn surface burner control knob to “OFF” position.



Repeat for left surface burner control knob.

**Grill module:** Remove grill grates and burner pan. Push in and turn right control knob to “LITE” position. The flame should light within 4 seconds. Turn the control knob to “HI” position after burner lights. **Do Not leave the knob in the “LITE” position after burner lights.**

Check the grill burner for proper flame. The small inner cone will be similar to the right-side surface burner flames, but will be shorter and softer. The outer cone is not as distinct as the inner cone. Turn grill burner control knob to “OFF” position.

Repeat for left grill burner control knob.

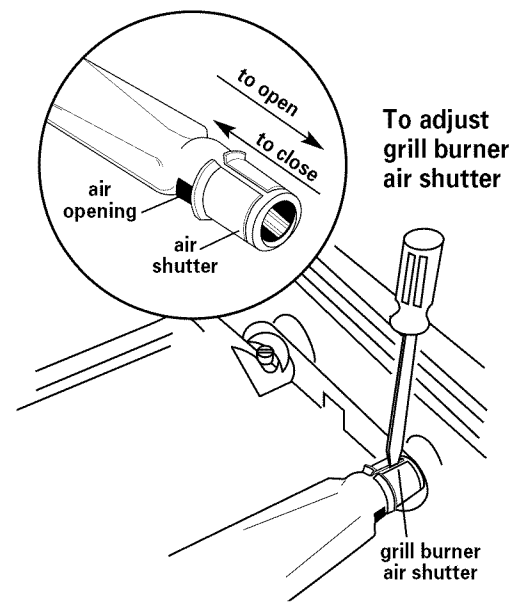

### If burner flames need adjusting –

- Remove surface burner grates and burner pan.
- Push in and turn control knob to “LITE” position and then to “HI” position.
- The right air shutter controls the front half of the burner; the left air shutter controls the rear half. Insert a screwdriver blade in the air shutter slot that needs adjusting and lightly twist the screwdriver to slide air shutter backward or forward to adjust the flame. Adjust the burner air shutter to the widest opening that will not cause the flame to lift or blow off the burner.
- Turn control knob to “OFF” position.
- Repeat if necessary for other burner control knob.

## 14.

Push in and turn each control knob to “LITE” position and then to “LO” position. The low flame should be a minimum, steady blue flame.

### If low flame needs adjusting –

- Remove the control knob and turn the adjustment screw in the center of the valve stem. Do Not turn screw more than 1/2 revolution in either direction.
- Replace the control knob. Check the adjustment by turning the control knob from “HI” to “LO” several times. The burner is properly adjusted when the low flame remains steady and the burner does not go out.
- Turn control knob to “OFF” position.
- Repeat if necessary for other burner control knob.
- Replace surface burner grates and burner pan or grill grates and burner pan.

**You have just finished installing your new downdraft cooktop. To get the most efficient use from your new cooktop, read your Use & Care Guide. Keep Installation Instructions and Guide close to cooktop for easy reference.**

# Gas conversions

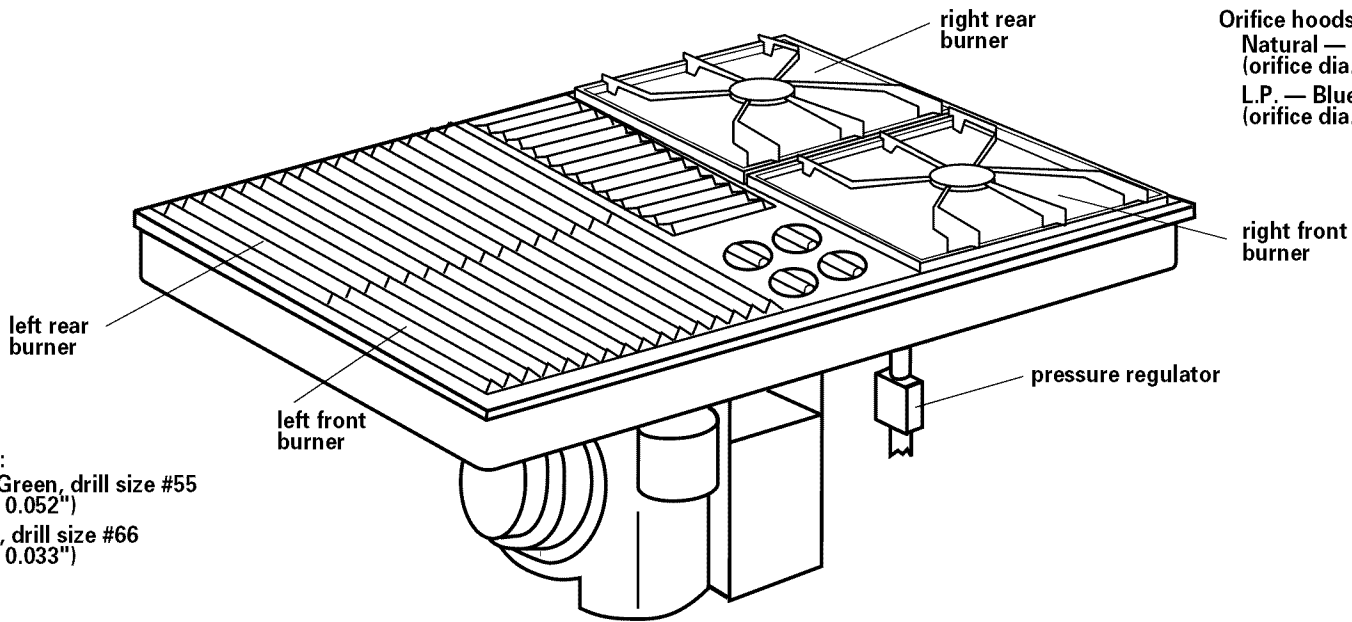

Orifice hoods:  
 Natural — Brass, drill size #53  
 (orifice dia. 0.0595")  
 L.P. — Blue, drill size #63  
 (orifice dia. 0.037")

Orifice hoods:  
 Natural — Green, drill size #55  
 (orifice dia. 0.052")  
 L.P. — Zinc, drill size #66  
 (orifice dia. 0.033")

Gas conversions (from Natural gas to L.P. gas; or from L.P. gas to Natural gas) must be done by a qualified installer.

**WARNING**

**Fire Hazard**

Shut off main gas supply line valve.  
 Make all conversions before turning gas supply valve back on.  
 Failure to follow these instructions could result in explosion, fire or other personal injury.

## L.P. gas conversion

**1.** Complete installation sections A-C (page 5) before converting cooktop to L.P. gas. Check that main gas supply line has been shut off and the power supply cord is disconnected.

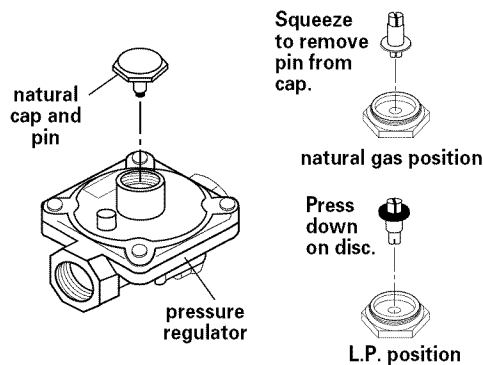

**DO NOT REMOVE THE PRESSURE REGULATOR.**

**2.** Turn cap on top of pressure regulator counterclockwise with a wrench to remove cap. Squeeze edges of pin with your fingers and pull upward to remove pin from cap. Turn pin over so disk end is up. Press down on disk to snap pin in place on cap. Reinstall cap on pressure regulator.

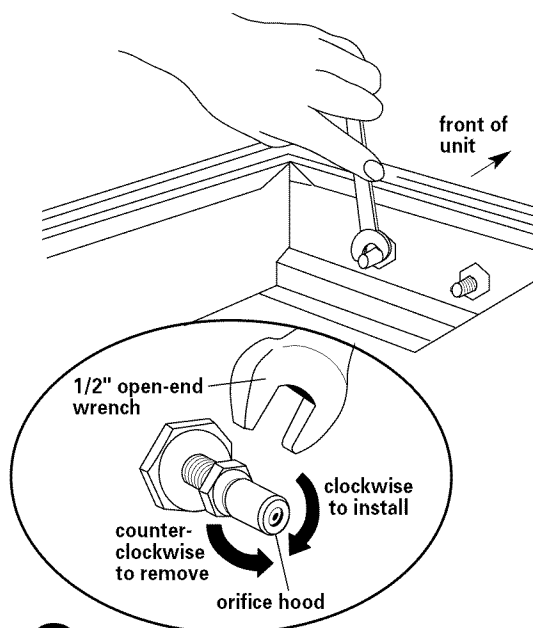

**3.** Remove Natural gas orifice hoods by turning hoods counterclockwise with 1/2" open-end wrench. Locate color-coded L.P. gas orifice hoods and sticker in plastic parts bag attached to right side of plenum.

- **Zinc-colored orifice hoods, drill size #66 (orifice dia. 0.033"):** Install on LEFT rear and front burners.
- **Blue-colored orifice hoods, drill size #63 (orifice dia. 0.037"):** Install on RIGHT rear and front burners.

Place Natural gas hoods in plastic parts bag for future use. Reattach bag to plenum.

**4.** Complete installation Sections D through E. L.P. gas flames have slightly yellow tips in addition to the other proper characteristics.

## Natural gas conversion

**1.** Shut off main gas supply line and disconnect the power supply cord.

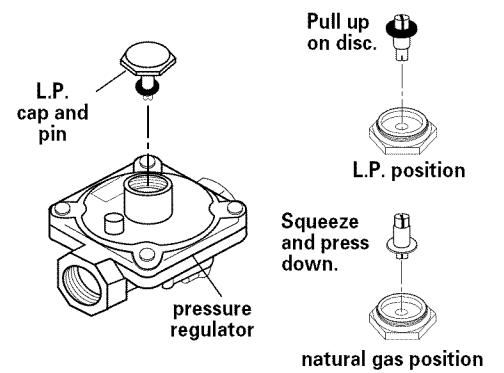

**DO NOT REMOVE THE PRESSURE REGULATOR.**

**2.** Turn cap on top of pressure regulator counterclockwise with a wrench to remove cap. Pull upward on edges of disk with your fingers to remove pin from cap. Turn pin over so disk end is down. Squeeze pin and snap it into place on cap. Reinstall cap on pressure regulator.

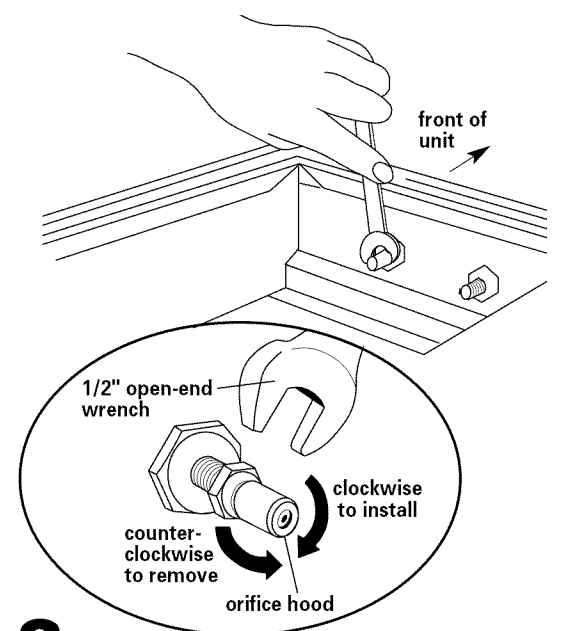

**3.** Remove surface burner and grille modules from cooktop. Remove L.P. gas orifice hoods by turning hoods counterclockwise with 1/2" open-end wrench. Locate color-coded Natural gas orifice hoods in plastic parts bag attached to bottom of cooktop.

- **Green-colored orifice hoods, drill size #55 (orifice dia. 0.052"):** Install on LEFT rear and front burners.
- **Brass-colored orifice hoods, drill size #53 (orifice dia. 0.0595"):** Install on RIGHT rear and front burners.

Place L.P. gas hoods and sticker in plastic parts bag for future use. Reattach bag to plenum.

**4.** After all the burners have been converted to Natural gas, plug the power supply cord into a grounded outlet. Adjust the air shutters and flame following the instructions in Section E. Natural gas burner flames do not have yellow tips.



# ***Cooktop removal***

## **If removing the cooktop is necessary for cleaning or maintenance:**

1. Shut off gas supply.
2. Disconnect gas and electrical supplies.
3. Disconnect vent duct system from unit inside cabinet.
4. Lift cooktop out of countertop to complete cleaning or maintenance.

## **After cleaning and maintenance:**

1. Reinstall cooktop in cutout.
2. Check that front edge of cooktop is parallel to front edge of countertop.
3. Connect gas and electrical supplies.
4. Connect vent duct system.

## **If cooktop does not operate:**

- Check that circuit breaker is not tripped or the house fuse blown.
- Check that the power supply cord is plugged into the wall receptacle.
- Check that the gas supply valves are turned to the "ON" position.
- See Use and Care Guide for troubleshooting list.

## **If you need assistance:**

Check your Use and Care Guide for a toll-free number to call, or call the dealer from whom you purchased this appliance. The dealer is listed in the Yellow Pages of your phone directory under "Appliances — Household — Major — Service and Repair."

When you call, you will need the cooktop model number and serial number. Both numbers can be found on the model/serial rating plate located on the bottom of the burner box.