

Installation Instructions

IMPORTANT: Read and save these instructions.

IMPORTANT:

Installer: Leave Installation Instructions with the homeowner.

Homeowner: Keep Installation Instructions for future reference.

Save Installation Instructions for local electrical inspector's use.

Compactor

Before you start...

Proper installation is your responsibility. Make sure you have everything necessary for correct installation. It is the personal responsibility and obligation of the customer to contact a qualified installer to assure that electrical installation meets national and all local codes and ordinances.

Grounded electrical outlet is required. (See "Electrical requirements," Page 2.)

Check the location where your compactor will be installed. The cabinet opening should be square. You should be able to fully open the compactor drawer. Six inches (15.2 cm) of clearance is needed on the right side of compactor drawer to be able to remove compactor bag. Allow 23 inches (58.4 cm) in front of the compactor to remove drawer.

Cutout dimensions

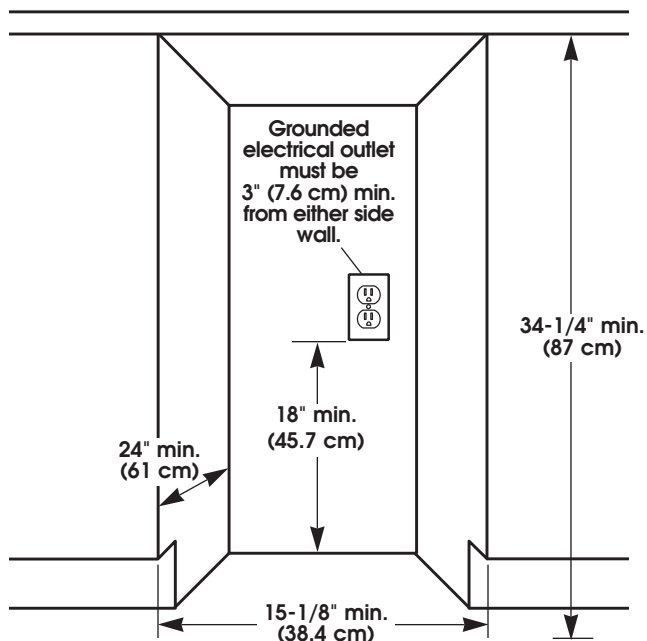

Product dimensions

The overall look of your compactor may vary.

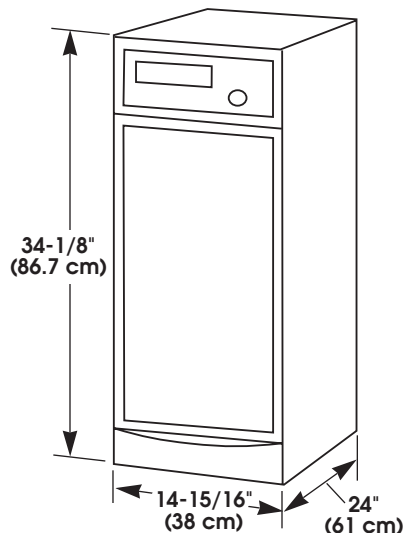

Clearance dimensions

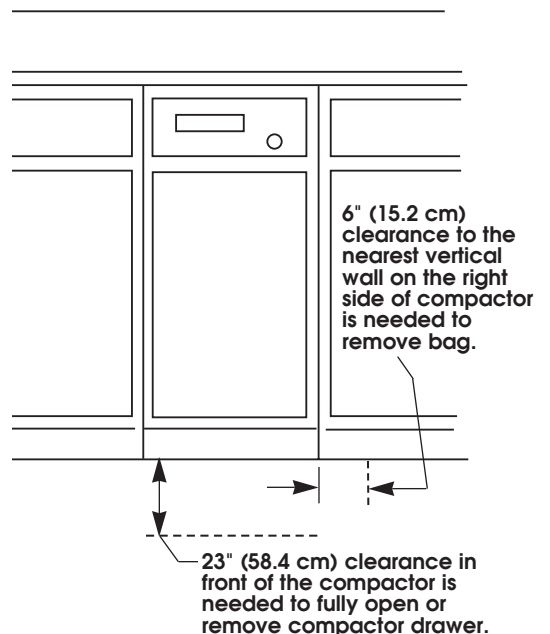

⚠ WARNING



Fire Hazard

Do not let any item fall or collect behind the compactor.

Failure to follow this instruction could result in a fire.

Tools and materials needed for installation:

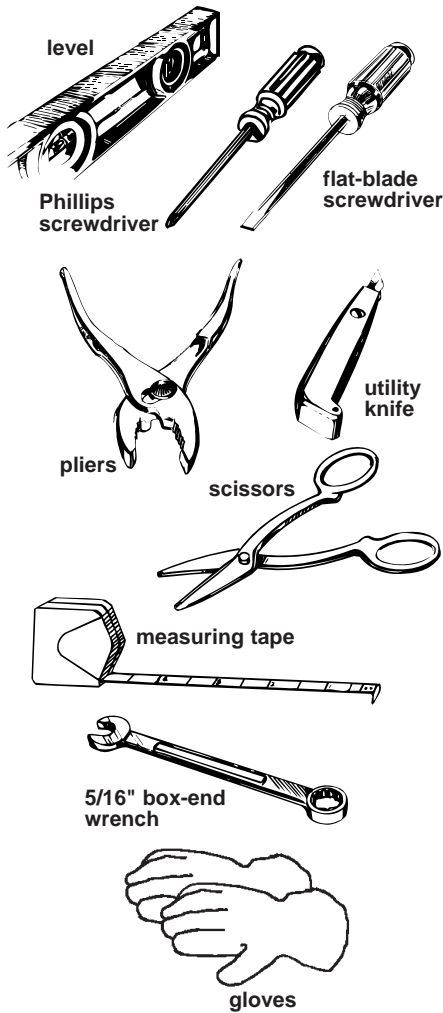

Parts supplied for undercounter installation:

- 1 LH retaining bracket
- 1 RH retaining bracket
- 2 retaining bracket screws #8-18 x 5/16"
- 2 mounting clips
- 2 mounting screws #8-18 x 1/2"

Remove parts from literature package.

Electrical requirements

⚠ WARNING

Electrical Shock Hazard
Electrical ground is required on this compactor.

Do Not ground to a gas pipe.

Do Not change the power supply cord plug. If it does not fit the outlet, have a proper outlet installed by a qualified electrician.

Do Not have a fuse in the neutral or grounding circuit. A fuse in the neutral or grounding circuit could result in an electrical shock.

Do Not use an extension cord with this compactor.

Check with a qualified electrician if you are not sure the compactor is properly grounded.

Failure to follow these instructions could result in death or serious injury.

If codes permit and a separate grounding wire is used, it is recommended that a qualified electrician determine that the grounding path is adequate.

Important: Observe all governing codes and ordinances.

A 120-volt, 60-Hz, AC-only, 15- or 20-ampere, fused electrical supply is required. Time-delay fuse or circuit breaker is recommended.

It is recommended that a separate circuit serving only this appliance be provided.

Recommended grounding method

For your personal safety, this appliance must be grounded. This appliance is equipped with a power supply cord having a 3-prong grounding plug. To minimize possible shock hazard, the cord must be plugged into a mating, 3-prong, grounding-type, wall receptacle, grounded in accordance with the National Electrical Code ANSI/NFPA 70 — latest edition* and all local codes and ordinances. If a mating wall receptacle is not available, it is the personal responsibility and obligation of the customer to have a properly grounded, 3-prong, wall receptacle installed by a qualified electrician.

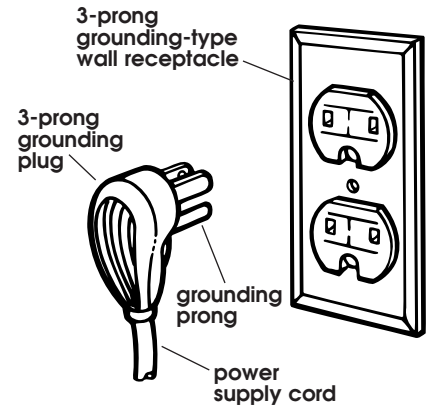

Copies of the standards listed may be obtained from:

- * National Fire Protection Association
 Batterymarch Park
 Quincy, Massachusetts 02269

Now start...

With compactor in room where it will be installed.

Do Not grasp console to move compactor.

Slide compactor onto cardboard or hardboard before moving compactor across floor to prevent damaging floor covering.

Do not allow the rear frame of the compactor to touch the floor covering when lifting or moving compactor.

1. Remove compactor from shipping carton. Remove all protective packaging materials such as tape and shipping pads. Remove waxy residue caused by protective shipping material with a mild solution of liquid household cleaner and water.

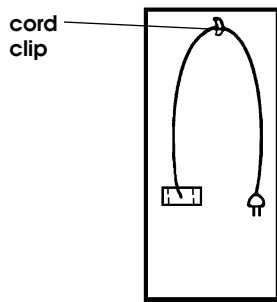

2. Check that power supply cord is attached to the cord clip on the rear of the compactor.

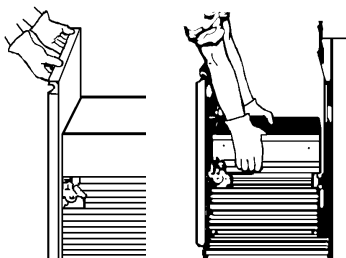

3. Place two corner posts from carton on floor near compactor. Open compactor drawer and remove any shipping materials or other items shipped in the drawer. Do Not remove the compactor bag (if installed). Grasp the handle and raise the front of drawer until it clears stops. Grasp sides of drawer and lift drawer out of compactor. Place the drawer on the two corner posts.

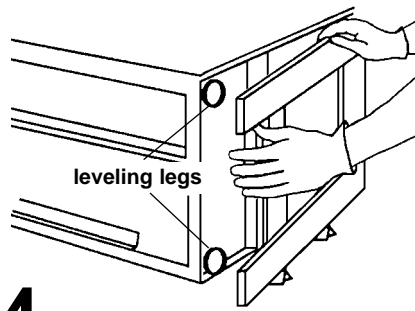

4. Place the other two corner posts on the floor to the side of the compactor. Grasp the sides of the compactor cabinet and put compactor on its side on top of the corner posts. Remove the shipping base from the bottom of compactor.

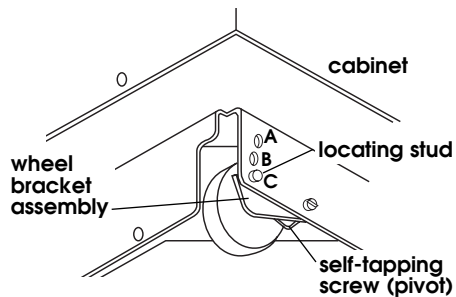

5. **Freestanding installation:** Go to Step 7.

Undercounter installation: Measure the height of your cabinet opening. The top of the compactor should be at least 1/8" (3 mm) from the top of the cabinet opening.

The rear wheels are preset for a cabinet opening height of 34-1/4" (87 cm) (Position "A").

To adjust for other cabinet opening heights, loosen screw just enough to clear stud from hole in position "A". Move the rear wheel and stud to position "B" or "C" as needed for your cabinet opening measurement:

Position B: 34-1/4" to 34-7/16" (87 to 87.5 cm)

Position C: 34-7/16" to 34-5/8" (87.5 to 88 cm)

Tighten screw. Repeat for other rear wheel.

6. Use pliers to lower leveling legs away from cabinet. Adjust legs so there will be a 1/8" (3 mm) to 1/4" (6.4 mm) space between the top of the compactor and the top of the cabinet opening. Stand the compactor upright.

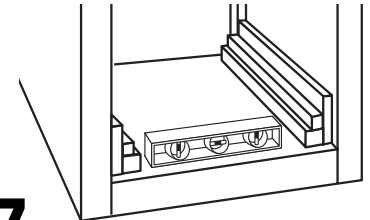

7. Use pliers to lower leveling legs away from cabinet. Place level inside on the floor of the cabinet. Check that the compactor is level from front to back and side to side. Adjust the leveling legs until the compactor is level.

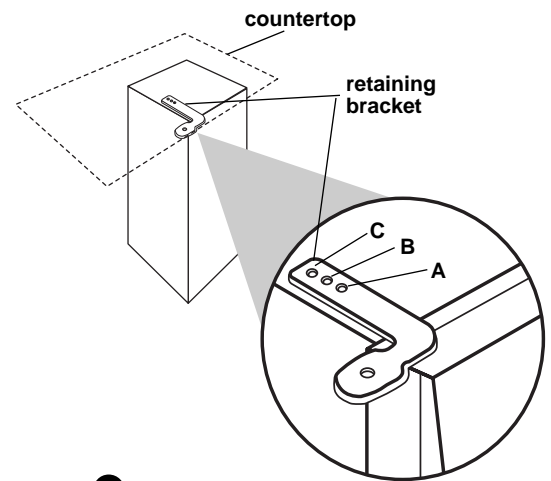

8. **Freestanding installation:** Go to Step 9.

Undercounter installation: For model with cabinet, remove the plastic plugs from the compactor cabinet top. Determine if you want the compactor frame or drawer front flush with the cabinet front.

Using the two #8 -18 x 5/16" screws, install the retaining brackets to cabinet top as needed:

If the compactor frame is to be flush with the cabinet front, place retaining bracket screws through "A".

If the compactor drawer front is to be flush with the cabinet front, place retaining bracket screws through "C".

If the compactor is to be midway between "A" and "C", place retaining bracket screws through "B".

⚠️ WARNING

Injury Hazard

When moving or lifting the compactor, use a glove to protect and cushion your hand.

More than one person is recommended to lift or move compactor because of its size and weight. Use proper lifting methods.

Failure to follow these instructions could result in injury.

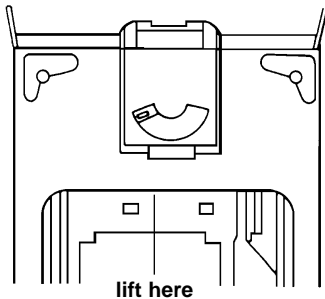

9. Move the compactor close to its final position. Plug the power supply cord into a properly grounded receptacle.

Freestanding installation:

Carefully move compactor into its final position. Check that compactor is still level. (See Step 7, Page 3.) Go to Step 10.

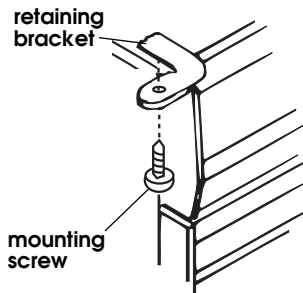

Countertop mounting

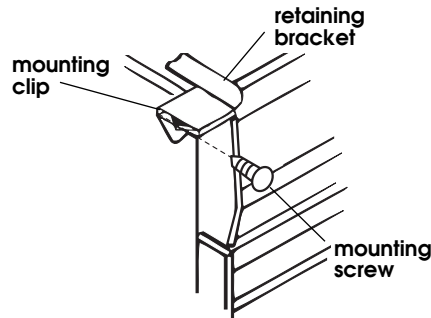

Cabinet-front mounting

Undercounter installation:

Carefully lift the front slightly and roll compactor into the cabinet opening until the retaining brackets stop the unit.

Using the two #8 -18 x 1/2" screws, fasten the retaining brackets to the underside of the countertop with the mounting screws. If brackets cannot be attached to the underside of countertop, attach mounting clips to brackets. Fasten compactor to cabinet front with mounting screws through mounting clips.

10. Grasp sides of compactor drawer and place bottom of drawer into tracks. Lift at the handle so the front of drawer will go over drawer stops. Close drawer. Check if drawer opens freely. If the toe plate rubs against floor, see "Adjusting the toe plate" for further instructions.

Adjusting the toe plate

If the toe plate rubs the floor covering, the toe plate clearance may be changed as follows:

- Mark on each side of the toe plate the amount of toe plate that rubs the floor covering.
- Remove the drawer from the unit. (See Step 3, Page 3.)
- Use a ruler and a pencil or chalk to draw a line between the marks on each side of toe plate.
- Use scissors or utility knife to cut toe plate along line.
- Replace drawer. (See Step 10.) If toe plate still rubs floor covering, repeat Steps a-f.

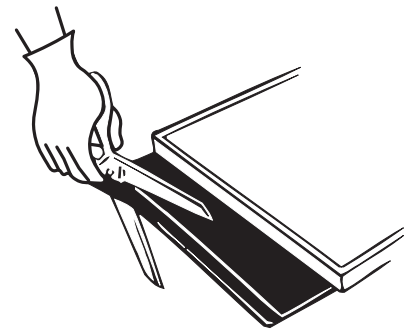

To get the most efficient use from your new compactor, read your Use and Care Guide/Operation Instructions. Keep literature close to compactor for easy reference.

Changing decorative panel

Models KCCC151, KUCC151 and YKCCC151

A custom-made flat or raised panel can be installed in place of the color panel. A new Trim Kit, (Part No. 9871381 brushed stainless steel, 9871382 white, 9871383 black or 9871384 almond) **must** be ordered. The front panel **must** be removed. Follow trim kit instructions to install your customized panel.

Paint, wallpaper or other material can be applied to a flat panel and installed with the new trim kit listed above. The existing compactor color panel and trim cannot be customized.

Custom-made panel dimensions

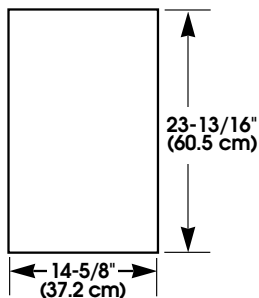

Flat panel: A $7/32$ " (5.6 mm) thick panel is required. This is the same thickness as a standard $1/4$ " plywood or paneling.

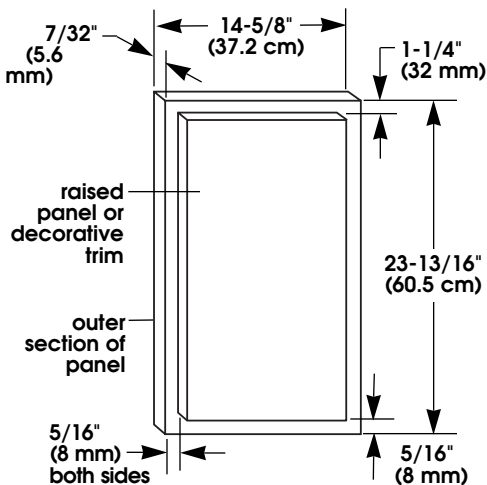

Raised panel: The outer section of panel must be $7/32$ " (5.6 mm) thick to fit into trim. Raised decorative trim or raised panel sections must be $5/16$ " (8 mm) from the side and bottom edges and $25/32$ " (20 mm) from the top edge of the outer section.

All other models

Changing color panel:

! WARNING

Injury Hazard

Wear gloves and handle panel(s) carefully.

Replace handle before operating compactor.

Failure to follow these instructions could result in injury.

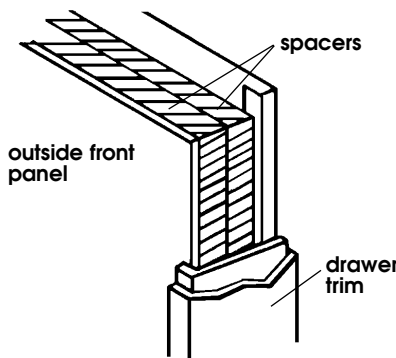

1. Remove the drawer from the unit. (See Step 3, Page 3.)
2. Remove the screws that attach the handle to the drawer.
3. Remove one spacer panel.
4. Remove color panel(s) by carefully pulling up.
5. Select the color you wish to show and carefully push that panel into the drawer trim.
6. Replace the spacer panels and other color panel.
7. Attach the handle.
8. Replace the drawer. (See Step 10, Page 4.)

Installing a custom-made panel:

Paint, wallpaper or other material can be applied to the color panel.

A custom-made flat or raised panel can be installed in place of the color panel(s) and spacers.

Custom-made panel dimensions

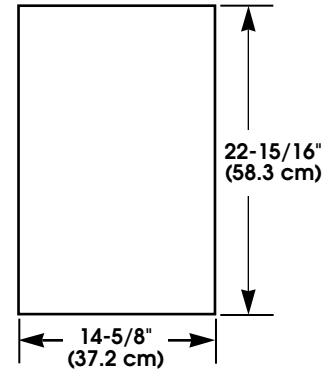

Flat panel: A $7/32$ " (5.6 mm) thick panel is required. This is the same thickness as a standard $1/4$ " plywood or paneling.

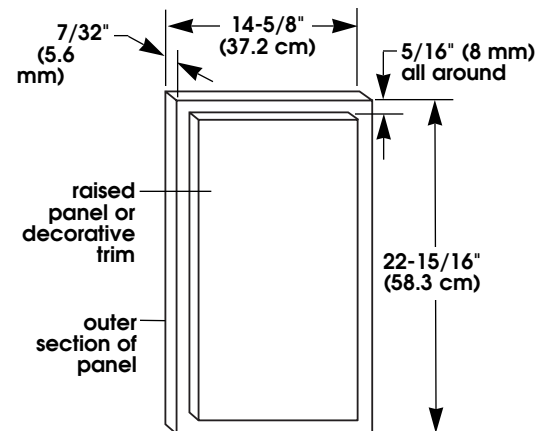

Raised panel: The outer section of panel must be $7/32$ " (5.6 mm) thick to fit into trim. Decorative trim or raised panel sections must be $5/16$ " (8 mm) from all edges of outer section.

1. Follow Steps 1 through 4 "Changing color panel," but remove all the cardboard spacers.
2. Slide customized panel into trim.
3. Reattach handle.
4. Replace the drawer. (See Step 10, Page 4.)

Before you call for service...

If your compactor does not operate properly, check the following before calling for service.

If the compactor won't operate:

- Is the power supply cord securely plugged into an electrical outlet?
- Has the house fuse blown or circuit breaker tripped?
- Is the drawer completely closed?
- Is the key-knob turned all the way to START position before it is released?

If compactor stops during operation:

- Push drawer in firmly while turning key-knob to START. Repeat if necessary.
- Rearrange trash load — Do Not load rigid items at front of drawer.

Trash not compacted:

- Drawer must be at least 1/3 full to see compaction.

Not enough compaction or force:

- Compacting works best when only a few items are loaded. Use the compacting cycle frequently.

Drawer won't open:

- Drawer will open only when ram is all the way up. To raise the ram, push drawer in firmly and turn key-knob to START. Release key-knob. Open drawer and lay items flat in center of drawer. Start compactor again.
- If you are using EXTRA PACK, DENSE PACK, SOLID PACK or COMPACT/HOLD, make sure the rocker switch is in the NORMAL position and the indicator light is OFF.

If you need assistance...

Check your Use and Care Guide for a toll-free number to call, or call the dealer from whom you purchased this appliance. The dealer is listed in the Yellow Pages of your phone directory under "Appliances — Household — Major — Service and Repair."

When you call, you will need the compactor model number and serial number. Both numbers are on the model/serial rating plate, which can be found by pulling out the drawer and looking on the left-hand side of the cabinet opening.