



Use and Care & Installation Guide

Air Conditioner

Contents

Adapter Plug	9	Grounding	9
Air Direction	5	Installation Instructions	8-13
Air Filter	6	Model and Serial Numbers	2, 6
Appliance Registration	2	Problem Solver	7
Care and Cleaning	6	Safety Instructions	2
Condenser Coils	6	User Maintenance Instructions	6
Consumer Services	15	Warranty	Back Cover
Control Settings	3, 4		
Electrical Requirements	8		
Energy-Saving Tips	5		
Extension Cords	9	GE Answer Center®	
Grille and Cabinet	6	800.626.2000	

Cool Only Models
 AJ806L AJX06L
 AJ808A AJX08A
 AJ810A AJM10A
 AJX09D AJM10D
 AJA12D

GE Appliances

419-7341

Help us help you...

Before using your air conditioner, read this book carefully.

It is intended to help you operate and maintain your new air conditioner properly.

Keep it handy for answers to your questions.

If you don't understand something or need more help, write (include your phone number):

Consumer Affairs
GE Appliances
Appliance Park
Louisville, KY 40225

Write down the model and serial numbers.

You'll find them on a label on the frame of the air conditioner behind the front grille. See how to remove the front grille on page 6.

These numbers are also on the Consumer Product Ownership Registration Card that came with your air conditioner. Before sending in this card, please write these numbers here:

Model Number

Serial Number

Use these numbers in any correspondence or service calls concerning your air conditioner.

If you received a damaged air conditioner...

Immediately contact the dealer (or builder) that sold you the air conditioner.

Save time and money. Before you request service...

Check the Problem Solver on page 7. It lists causes of minor operating problems that you can correct yourself.

Important Safety Instructions

Read all instructions before using this appliance.

When using this appliance, always exercise basic safety precautions, including the following:

- **Use this appliance only for its intended purpose as described in this Use and Care Guide.**
- **This air conditioner must be properly installed in accordance with the Installation Instructions before it is used.** See grounding instructions on page 9.
- **Never unplug your air conditioner by pulling on the power cord.** Always grip plug firmly and pull straight out from the receptacle.
- **Repair or replace immediately all electric service cords that have become frayed or otherwise damaged.** Do not use a cord that shows cracks or abrasion damage along its length or at either the plug or connector end.
- **Unplug your air conditioner before making any repairs.** Note: We strongly recommend that any servicing be performed by a qualified individual.

- **For your safety...do not store or use combustible materials, gasoline or other flammable vapors or liquids in the vicinity of this or any other appliance.**

SAVE THESE INSTRUCTIONS

If You Need Service

To obtain service, see the Consumer Services page in the back of this book.

We're proud of our service and want you to be pleased. If for some reason you are not happy with the service you receive, here are three steps to follow for further help.

FIRST, contact the people who serviced your appliance. Explain why you are not pleased. In most cases, this will solve the problem.

NEXT, if you are still not pleased, write all the details (including your phone number) to:

Manager, Consumer Relations
GE Appliances
Appliance Park
Louisville, Kentucky 40225

FINALLY, if your problem is still not resolved, write:

Major Appliance
Consumer Action Panel
20 North Wacker Drive
Chicago, Illinois 60606

Operating Your Air Conditioner Controls

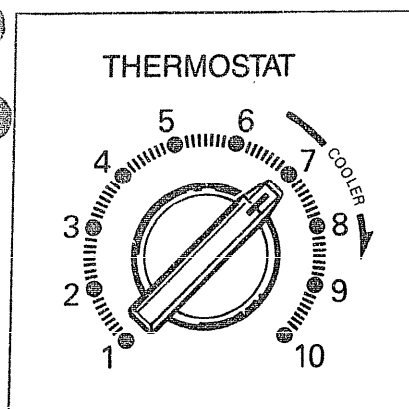

Thermostat Control

When you turn this control to the desired setting, the thermostat will automatically control the temperature of the indoor air. The higher the number selected, the cooler the indoor air will be.

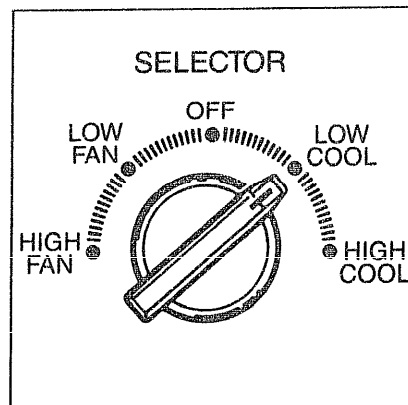

Selector Switch

OFF turns air conditioner off.

HIGH FAN provides high fan speed operation without cooling or heating.

LOW FAN provides low fan speed operation without cooling or heating.

LOW COOL provides cooling with low fan speed operation.

HIGH COOL provides cooling with high fan speed operation.

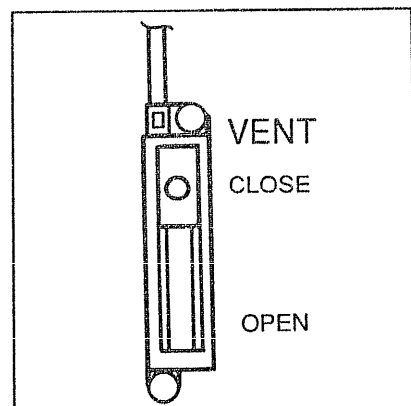

Ventilation Control

When this control is set at **CLOSE**, only the air inside the room can be circulated and conditioned. When it's in the **OPEN** position, some indoor air can be exhausted from the room.

Fan Switch

The Fan Switch, located behind the front grille, is set at **CONTINUOUS** at the factory to provide continuous fan operation in cool mode. See how to remove the front grille on page 6.

If you want the fan to cycle on and off with the compressor, set the Fan Switch at **CYCLE**.

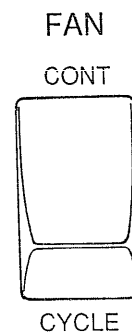

Operating the Controls

Operating Your Air Conditioner Controls (continued)

For Normal Cooling

1. Set Selector Switch at HIGH COOL.
2. Set Thermostat Control at desired number (usually the midpoint is a good starting position). If room temperature is not satisfactory after a reasonable time, set the temperature control at a higher number for a cooler room or at a lower number for a warmer room.

For Maximum Cooling

1. Set Selector Switch at HIGH COOL.
2. Set Thermostat Control at 10.
3. Set Ventilation Control at CLOSE position.
4. Shift Fan Switch to CONTINUOUS.

For Quieter Operation

1. Set Selector Switch at LOW COOL.
2. Set Thermostat Control at desired number.
3. Set Ventilation Control at CLOSE position.
4. Shift Fan Switch to desired position—CONTINUOUS or CYCLE.

For Nighttime Operation

During the cooler evening hours, it is recommended that you set the Selector Switch at LOW COOL for very quiet operation and the Thermostat Control at mid-range (5 or 6).

When the Thermostat Control is set on 9 or 10 and the Fan is set on low speed, moisture may freeze on the coils and prevent the unit from cooling. If this happens, set the Fan at high speed and set the Thermostat Control to a lower number.

For Extreme Temperatures

For greatest economy and best performance, we suggest you always set the Selector Switch at HIGH COOL in extremely hot weather.

For air circulation and filtering without cooling

Set Selector Switch at HIGH FAN or LOW FAN.

For Ventilation

Whether controls are set for cooling or fan only operation, setting the Ventilation Control at OPEN lets room air be exhausted to the outside. This is helpful in removing stale air, smoke or odors from the room, and permits outdoor air to enter through normal openings in the house. However, cooling effectiveness is reduced when this control is set at OPEN, so we suggest you don't keep it there long—especially in hot, humid weather.

Energy-Saving Tips

To Adjust Air Direction

Up-and-down air direction:

Adjust louvers with your fingertips to direct discharged air up, down or straight ahead.

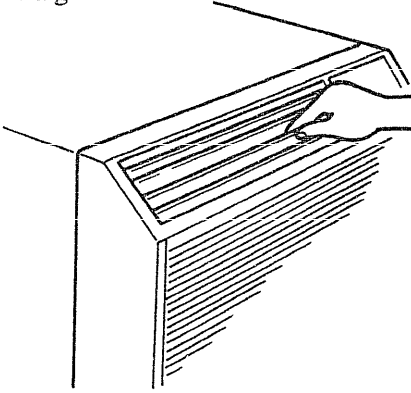

Side-to-side air direction:

Remove the front grille (see page 6). Adjust louvers with your fingertips to direct discharged air to the left, to the right or straight ahead. Replace grille.

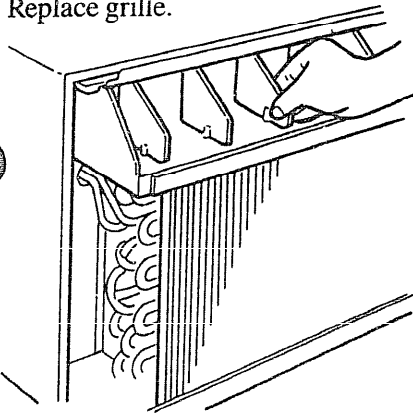

- Keep the air filter clean. (See instructions on page 6.)
- For most efficient cooling, keep vent in closed position except when you want to exhaust air, smoke or odors from the room.
- Don't let the room get too hot or too cold. Whenever possible, turn the unit on before the room heats up or cools down.
- Keep windows and doors closed. Conditioned air escapes when they're open.
- Keep furnace floor registers and cold air returns closed. Conditioned air can easily escape through them.
- Don't block front of unit when it is operating. Curtains or drapes blocking it will restrict air flow.
- It's best to operate your air conditioner at high speed during extremely hot or cold weather.
- Keep outdoor condenser coil clean. (See page 6.)
- Turn air conditioner off before vacations or extended absences from home.

Care and Cleaning

USER MAINTENANCE INSTRUCTIONS

Turn air conditioner off and remove the plug from the wall outlet before cleaning.

Grille & Cabinet

Wipe both sides of grille with a clean cloth lightly dampened with mild liquid dishwashing detergent, or clean with a vacuum cleaner brush. Be careful not to force the movable louvers out of position.

Other areas behind the grille may be wiped or vacuumed, taking care not to damage the coil fins.

Wash cabinet with mild soap or detergent and lukewarm water. Never use strong chemicals, solvents or bleaching agents.

Condenser Coils

These coils on the weather side of the unit should be checked periodically and cleaned if clogged with dirt or soot from the atmosphere. If extremely soiled, they may need to be steam cleaned, a service available through your GE service outlet.

Air Filter

The air filter behind the front grille should be checked and cleaned at least every 30 days or as often as it needs cleaning.

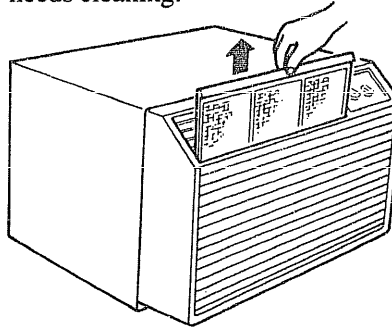

To remove the filter:

Grasp the tab at the air outlet on the front grille and pull it straight up.

Clean the filter with a vacuum cleaner to remove light dust. Wash the filter in lukewarm, soapy water and rinse in clear water to remove sticky dust.

When replacing the filter, be sure the word FRONT is facing you as you slide the filter back into place.

Front Grille Removal

The front grille can be removed for more thorough cleaning or to make the model and serial numbers accessible.

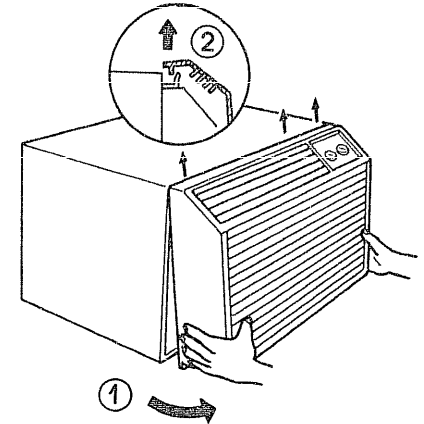

To remove the front grille:

1. Grasp the bottom of the grille and swing it toward you about 4 inches.
2. Slide the grille upward to free the three tabs at the top of the grille from slots in the top of the chassis.

To replace the grille, hook top of grille onto top of chassis and push bottom of grille in until it snaps into place.



Questions? Use This Problem Solver

PROBLEM	POSSIBLE CAUSE AND REMEDY
AIR CONDITIONER DOES NOT OPERATE	<ul style="list-style-type: none">• Not plugged in. Plug may have been bumped loose by vacuum cleaner or furniture.• If plugged in, fuse could have blown or circuit breaker may have been tripped.
AIR CONDITIONER "DOES NOT COOL AS IT SHOULD"	<ul style="list-style-type: none">• Curtains, blinds or furniture blocking front of air conditioner will restrict air flow.• Thermostat Control may not be set high or low enough. Also, when Fan Switch is at CYCLE, the temperature in the room will vary more than when it's at CONTINUOUS. Turn knob to another number. Highest setting should provide maximum cooling.• Air filter dirty, should be cleaned at least every 30 days. See instructions on page 6.• Room may have been very hot when air conditioner was first turned on. Allow time for it to cool down.• Cold air may be escaping through open furnace floor registers and cold air returns.• Ventilation Control may be set at OPEN, allowing outside air to enter room.• Cooling coils have iced up. To melt ice, set the Fan at high speed and the Thermostat Control to a lower number.
OPERATING SOUNDS	<ul style="list-style-type: none">• Thermostat click, a metallic sound, may be heard when compressor cycles on and off. This is normal.• Fan cycles on and off with compressor when Fan Switch behind front grille is at CYCLE and Selector Switch is in cool or heat position. Otherwise, fan runs continuously when air conditioner is on.
WATER DRIPPING OUTSIDE	<ul style="list-style-type: none">• Excess water may overflow in extremely hot and humid weather. This is normal.
WATER DRIPPING INSIDE	<ul style="list-style-type: none">• Air conditioner must be installed level or tilted slightly to the outside for proper water disposal.
WATER IN BASE PAN (ON OUTDOOR SIDE)	<ul style="list-style-type: none">• This is normal for a short period in areas with little humidity; normal for a longer period in very humid areas. Moisture removed from indoor air drains to rear of cabinet where it is picked up by a fan and thrown against the outdoor condenser coil.

If you need more help...call, toll free:
GE Answer Center®
800.626.2000
consumer information service

The Problem Solver

Installation Instructions

IMPORTANT: Leave these instructions with the appliance.
OWNER: Keep these instructions for future use.

Electrical Safety— IMPORTANT... Please Read Carefully.

How to connect electricity

For personal safety, this appliance must be properly grounded.

Electrical requirements

115-volt models require a 115/120-volt a.c., 60 hz grounded outlet protected with a 15 amp time delay fuse or circuit breaker.

The power cord on these models has a three-prong (grounding) plug that mates with a standard three-prong (grounding) wall outlet (Fig. 1) to minimize the possibility of electric shock hazard from these appliances.

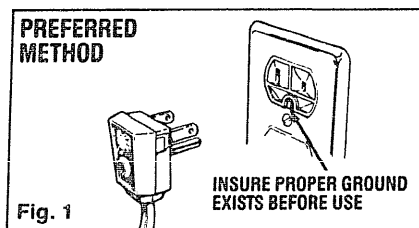

Where a standard two-prong wall outlet is encountered, it is your personal responsibility and obligation to have it replaced with a properly grounded three-prong wall outlet.

DO NOT, UNDER ANY CIRCUMSTANCES, CUT OR REMOVE THE THIRD (GROUND) PRONG FROM THE POWER CORD.

230/208-volt models require their own single branch circuit supplying 230/208-volt a.c., protected with a time delay fuse or circuit breaker. This is recommended for best performance and to prevent overloading house wiring circuits, which could cause a possible fire hazard from overheating wires.

The power cord on these models has a 230/208-volt perpendicular, tandem or large tandem type plug that mates respectively with a 230/208-volt perpendicular, tandem or large tandem type wall outlet. These types of outlets are available at most hardware stores.

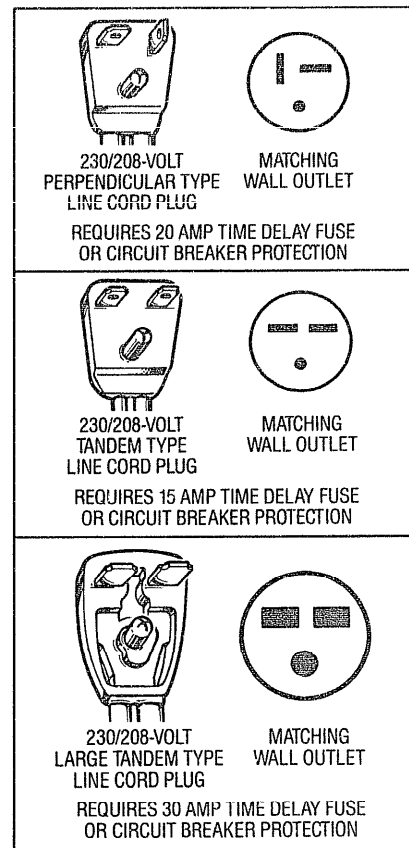

Whether your air conditioner is a 115-volt or a 230/208-volt unit, it is important to have the wall outlet and circuit checked by a qualified electrician if there is any doubt as to whether a proper ground exists.

Use of adapter plug (115-volt models only)

Because of potential safety hazards under certain conditions, we **strongly recommend against use of an adapter plug.** However, if you still elect to use an adapter, where local codes permit, a **TEMPORARY CONNECTION** may be made to a properly grounded two-prong wall outlet by use of a UL listed adapter (Fig. 2) available at most local hardware stores.

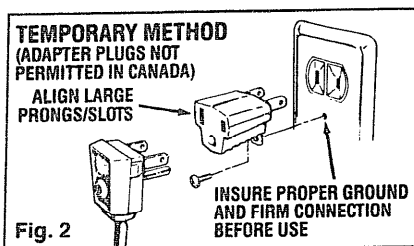

The larger slot in the adapter must be aligned with the larger slot in the wall outlet to provide proper polarity in the connection of the power cord.

CAUTION: Attaching the adapter ground terminal to wall outlet cover screw does not ground the appliance unless cover screw is metal, and not insulated, and wall outlet is grounded through house wiring. You should have the circuit checked by a qualified electrician to make sure the outlet is properly grounded.

When **disconnecting the power cord from the adapter**, always hold the adapter with one hand. If this is not done, the adapter ground terminal is very likely to break with repeated use.

Should the adapter ground terminal break, **DO NOT USE** the appliance until a proper ground has again been established.

Use of extension cords

Because of potential safety hazards under certain conditions, we **strongly recommend against the use of an extension cord.** However, if you still elect to use an extension cord, it is absolutely necessary that it be a UL listed 3-wire grounding type appliance extension cord and that the current carrying rating of the cord in amperes be equal to or greater than the branch circuit size shown on the rating nameplate of the appliance.

Window Mounting (AJ8 models)

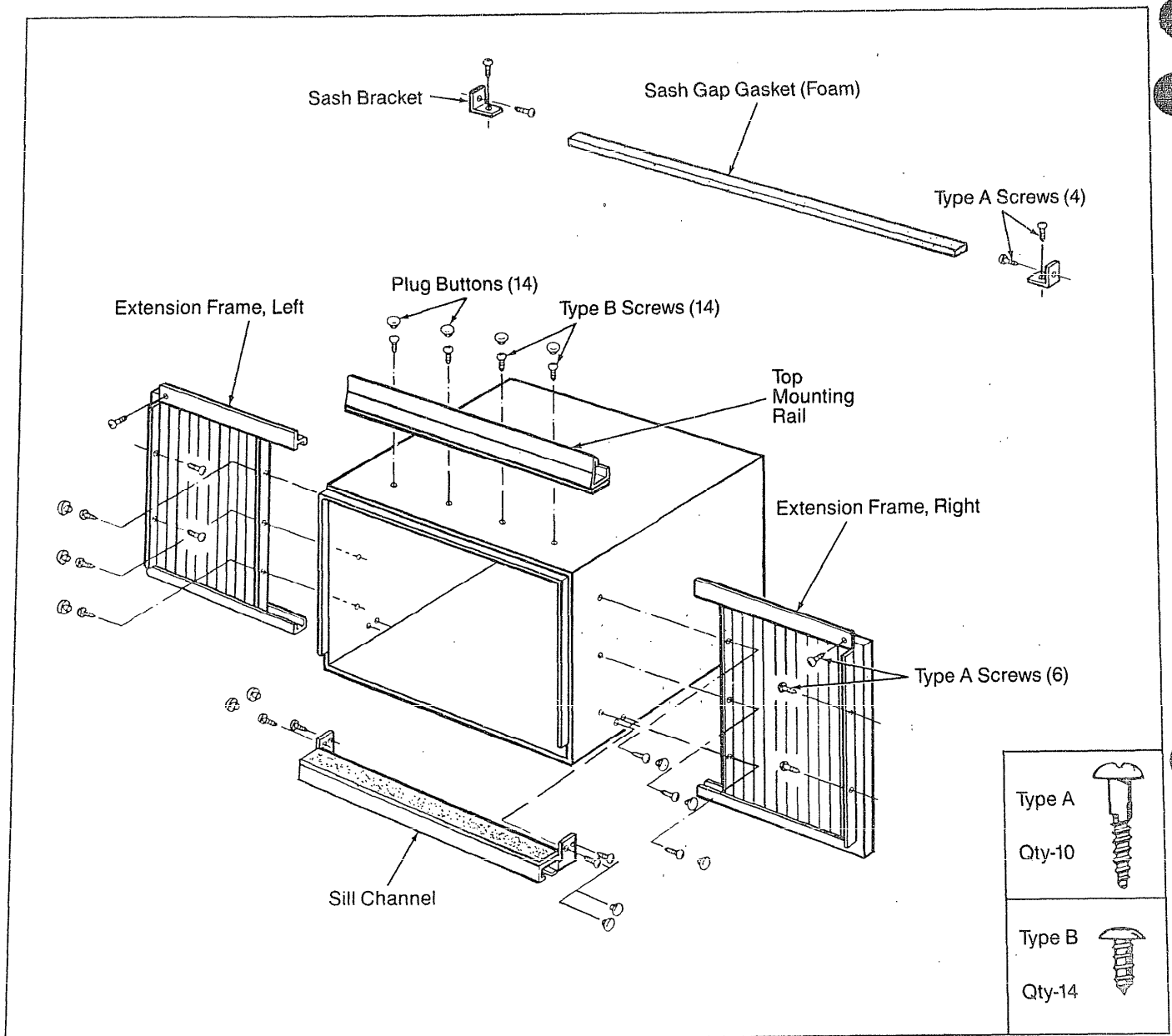

Tools Needed

- Phillips head screwdriver
- Adjustable wrench
- Wood saw
- Scissors or knife

Window Requirements

- Standard double-hung window with actual opening width of 31" to 41".
- Clear, vertical opening of 17" minimum from bottom of sash to stool.
- Stool offset (height between sill and stool) must be less than 1½".

Note: All supporting parts should be secured to firm wood, masonry or metal.

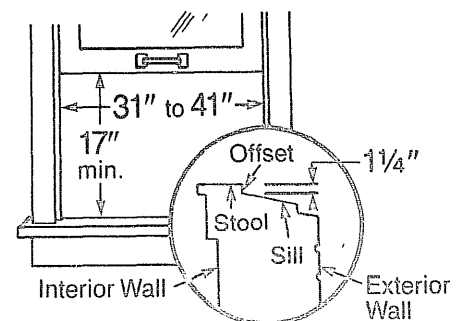

1. Prepare the Chassis.

(AJ8 models only—AJA, AJM and AJX models are shipped with chassis and front grille only.)

1. Remove chassis from cabinet.
2. Loosen the locking screw (A), then turn the chassis locking plate 90° downward as shown.

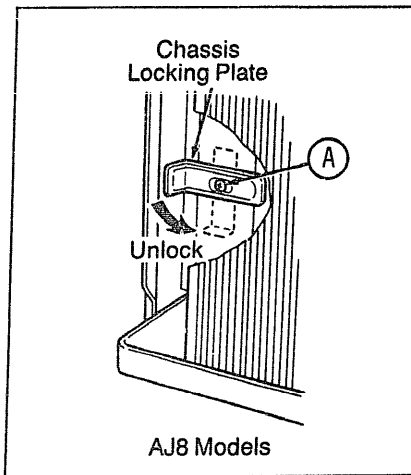

3. Loosen the ground screw (B), then remove the ground wire. Save the ground wire for reinstallation later.

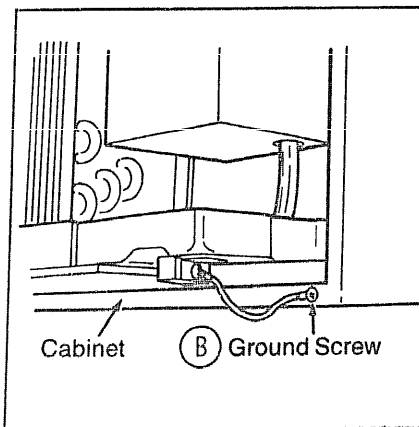

4. Pull the bottom corners of the chassis and slide it out from the cabinet.

2. Mount the Rear Grille.

1. While holding the grille at a 45° angle, insert it into clips at the top of the case and push it toward the unit. Keep slight upward pressure on the grille until it fits flush with the bottom of the cabinet.

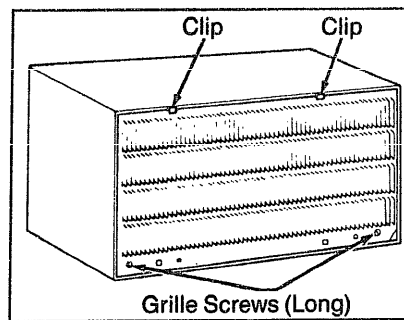

2. Secure the bottom of the grille with 2 long grille screws provided with the grille.

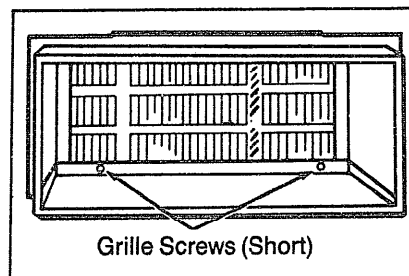

Note: The rear grille may be installed from the room side with 2 short screws provided with the grille.

3. Install Filler Curtains.

1. Install the top mounting rail onto the top of the cabinet with 4 Type B screws.

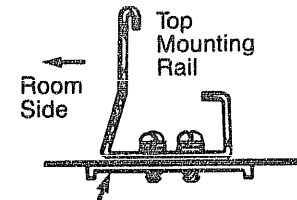

2. Secure the sill channel to both sides of the cabinet with 4 Type B screws—2 on each side.

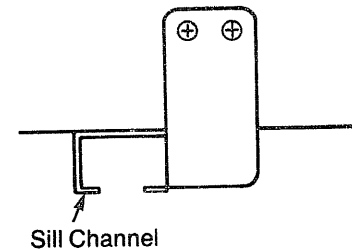

3. Insert the left and right extension frames into the top mounting rail and the sill channel.

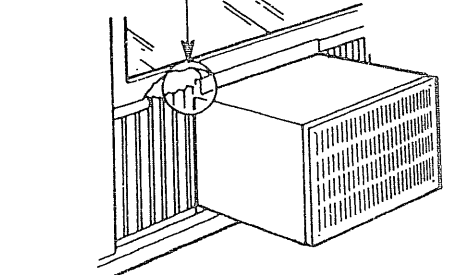
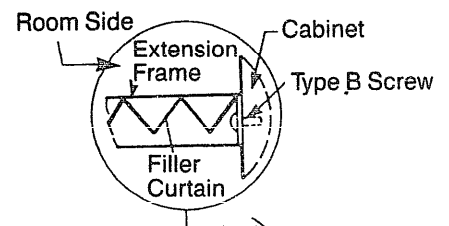

4. Secure the filler curtains in the extension frames to both sides of the cabinet with 6 Type B screws—3 on each side.

(continued next page)

Window Mounting (AJ8 models)

(continued)

4. Install Cabinet in Window.

1. Measure and mark the center of the window sill to establish the mounting position of your unit.

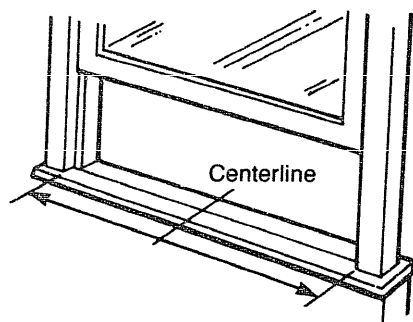

2. Lift the window sash and insert the cabinet into the opening. Center the cabinet on the line marked on the window stool, and position the sill channel into the stool offset. Pull the top of the cabinet toward you and lower the window sash behind the top mounting rail. The cabinet should be level or with 1/8" pitch toward the outside.

3. Pull the window sash down on top of the unit. For safety purposes, attach the sash locking brackets with 4 type A screws—2 on each side.

4. Cut the foam sash gap gasket to window width and stuff it between the top of the lower sash and glass panes of the upper sash. The foam gasket should be flush with the top of the lower sash.

5. Plug cabinet holes not used for mounting with plug buttons.

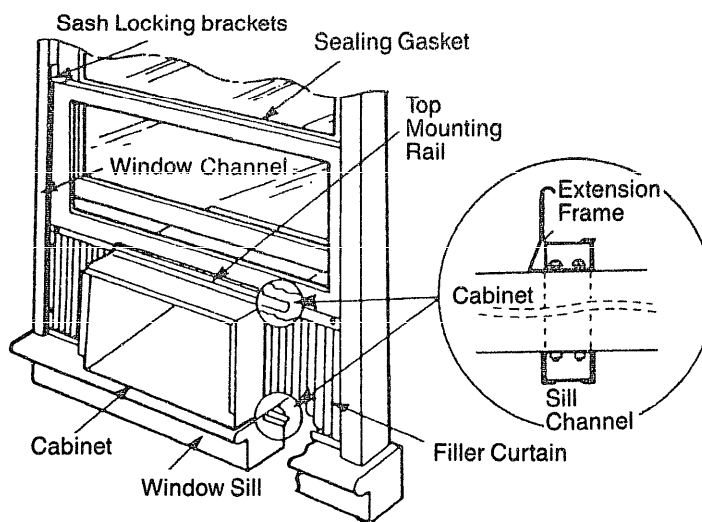

6. Seal small openings around the cabinet with gum-type sealer, provided.

7. Extend and secure the left and right extension frames to the window sash and the sill channel with 6 Type A screws—3 on each side.

To Install Chassis into Cabinet or Wall Sleeve...

1. Slide the chassis into the installed cabinet (provided with AJ8 models) or wall sleeve RAB36, RAB37 or RAB38 (not provided) designed for AJA, AJM and AJX models. Make sure that the tubing on the unit is not touching the wall case and that the wall case insulation is secure.

2. Turn the chassis locking plate 90° upward and lock the chassis with the plate.

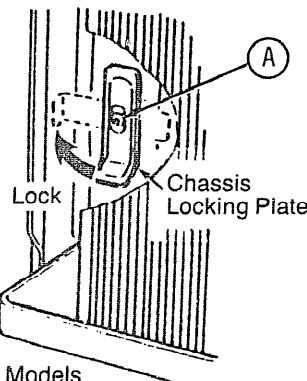

AJ8 Models

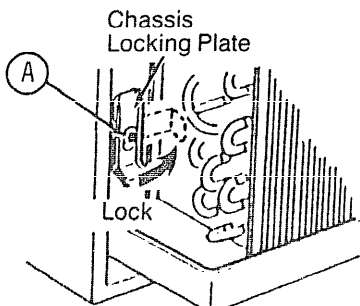

AJA, AJM, AJK Models

3. Secure the line cord to the base pan with the clamp provided.

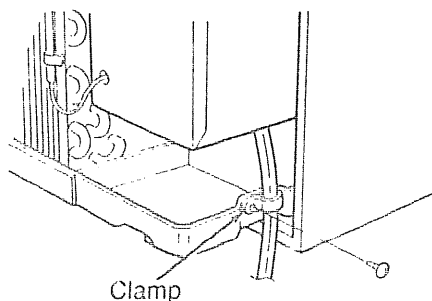

Ground Wire on AJ8 models, disconnected when the chassis was removed from the cabinet, must be reconnected to the cabinet as shown in step 3 under *Prepare the Chassis* on page 11.

WHEN THE LINE CORD RUN IS TO THE LEFT SIDE OF THE UNIT, extend enough cord to reach the wall receptacle. (Excess cord length may be stored in the space just below the electrical component box). Insert the line cord under the clamp provided with the unit.

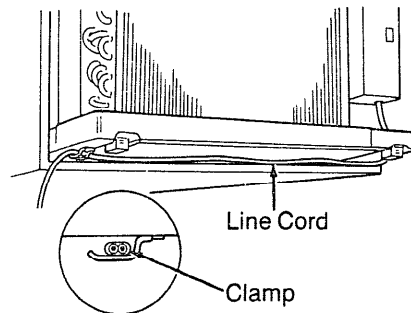

This step must be followed before reinstalling the chassis locking plate.

4. Mount the grille on the front of the chassis by hooking the top of the grille onto the top of the chassis and pushing bottom of grille in until it snaps into place.

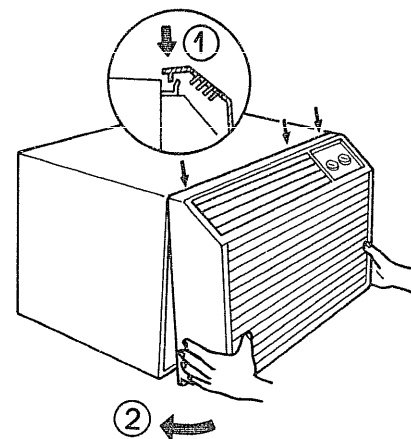

We'll Be There

With the purchase of your new GE appliance, receive the assurance that if you ever need information or assistance from GE, we'll be there. All you have to do is call—toll-free!

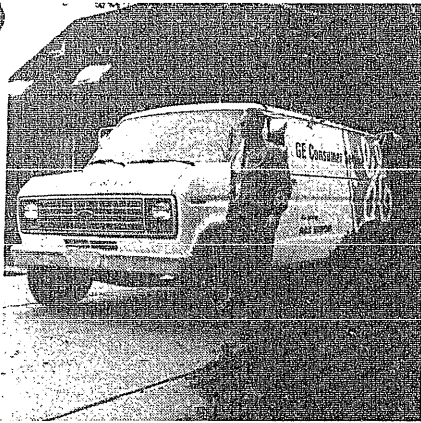

GE Answer Center®
800.626.2000

Whatever your question about any GE major appliance, GE Answer Center® information service is available to help. Your call—and your question—will be answered promptly and courteously. And you can call any time. GE Answer Center® service is open 24 hours a day, 7 days a week.

In-Home Repair Service

800-GE-CARES
(800-432-2737)

A GE Consumer Service professional will provide expert repair service, scheduled at a time that's convenient for you. Many GE Consumer Service company-operated locations offer you service today or tomorrow, or at your convenience (7:00 a.m. to 7:00 p.m. weekdays, 9:00 a.m. to 2:00 p.m. Saturdays). Our factory-trained technicians know your appliance inside and out—so most repairs can be handled in just one visit.

Service Contracts

800-626-2224

You can have the secure feeling that GE Consumer Service will still be there after your warranty expires. Purchase a GE contract while your warranty is still in effect and you'll receive a substantial discount. With a multiple-year contract, you're assured of future service at today's prices.

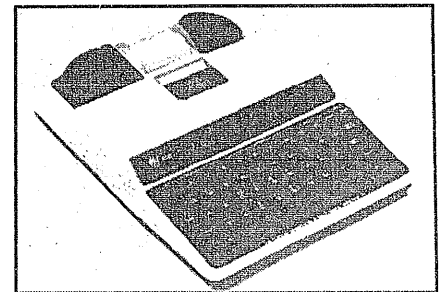

Telecommunication Device for the Deaf

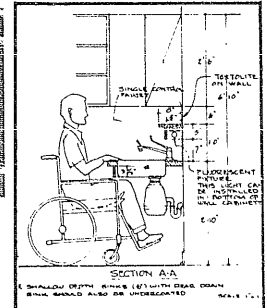
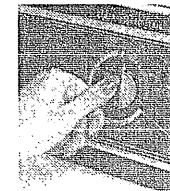

Parts and Accessories

800-626-2002

Individuals qualified to service their own appliances can have needed parts or accessories sent directly to their home, free of shipping charge! The GE parts system provides access to over 47,000 parts...and all GE Genuine Renewal Parts are fully warranted. VISA, MasterCard and Discover cards are accepted.

User maintenance instructions contained in this booklet cover procedures intended to be performed by any user. Other servicing generally should be referred to qualified service personnel. Caution must be exercised, since improper servicing may cause unsafe operation.

For Customers With Special Needs...

800.626.2000

Upon request, GE will provide Braille controls for a variety of GE appliances, and a brochure to assist in planning a barrier-free kitchen for persons with limited mobility. To obtain these items, free of charge, call 800.626.2000.

Consumers with impaired hearing or speech who have access to a TDD or a conventional teletypewriter may call 800-TDD-GEAC (800-833-4322) to request information or service.



YOUR GE ROOM AIR CONDITIONER WARRANTY

Save proof of original purchase date such as your sales slip or cancelled check to establish warranty period.

WHAT IS COVERED

FULL ONE-YEAR WARRANTY

For one year from date of original purchase, we will provide, free of charge, parts and on-site service labor to repair or replace *any part of the room air conditioner* that fails because of a manufacturing defect.

FULL FIVE-YEAR WARRANTY

For five years from the date of original purchase, we will provide, free of charge, parts and on-site service labor to repair or replace *any part of the sealed refrigerating system* (the compressor, condenser, evaporator and all connecting tubing) that fails because of a manufacturing defect.

For each of the above warranties: Transportation expense to and from a service shop and shop service labor if required will be free of charge.

This warranty is extended to the original purchaser and any succeeding owner for products purchased for use in the 48 mainland states, Hawaii and Washington, D.C. In Alaska the warranty is the same except that it is LIMITED because you must pay to ship the product to the service shop or for the service technician's travel costs to your home.

All warranty service will be provided by our Factory Service Centers or by our authorized Customer Care® servicers during normal working hours.

Look in the White or Yellow Pages of your telephone directory for GENERAL ELECTRIC COMPANY, GENERAL ELECTRIC FACTORY SERVICE, GENERAL ELECTRIC-HOTPOINT FACTORY SERVICE or GENERAL ELECTRIC CUSTOMER CARE® SERVICE.

WHAT IS NOT COVERED

- Service trips to teach you how to use the product.

Read your Use and Care material. If you then have any questions about operating the product, please contact your dealer or our Consumer Affairs office at the address below, or call, toll free:

GE Answer Center®
800.626.2000
consumer information service

- Improper installation.

If you have an installation problem, or if the air conditioner is of improper cooling or heating capacity for the intended use, contact your dealer or installer. You are responsible for providing adequate electrical connecting facilities.

- Replacement of fuses or resetting of circuit breakers.

- In commercial locations labor necessary to move the unit to a location where it is accessible for service by an individual technician.

- Failure of the product resulting from modifications to the product or due to unreasonable use including failure to provide reasonable and necessary maintenance.

- Failure due to corrosion on models not corrosion-protected.

- Damage to the product caused by improper power supply voltage, accident, fire, floods or acts of God.

WARRANTOR IS NOT RESPONSIBLE FOR CONSEQUENTIAL DAMAGES.

Some states do not allow the exclusion or limitation of incidental or consequential damages, so the above limitation or exclusion may not apply to you. This warranty gives you specific legal rights, and you may also have other rights which vary from state to state. To know what your legal rights are in your state, consult your local or state consumer affairs office or your state's Attorney General.

Warrantor: General Electric Company

If further help is needed concerning this warranty, write:
Manager—Consumer Affairs, GE Appliances, Louisville, KY 40225