

**MICROWAVE OVEN HOODS**

**WARNING**  
**NEVER TOUCH OR SERVICE THE HIGH VOLTAGE CIRCUIT WITHOUT DISCHARGING CAPACITOR BY SHORTING ACROSS ITS TERMINALS. TO AVOID POSSIBLE ELECTRICAL SHOCK.**

**OVEN THERMAL CUTOUT (FLAME SENSOR)**

The Oven Thermal Cutout is located on the top side of the Oven Cavity beside Exhaust duct with a temperature rating of 212°F.(100°C.) The cutout is tightly held to the top of the oven cavity by a spring clip.

**NOTE :** If cutout cannot be removed from clip oven will have to be removed from installation and outer case removed.

**ANTENNA**

The antenna is motor driven and located on the upper side of the cavity. The oven uses a top feed wave guide. The antenna blade is located in the wave guide and the motor is located on the wave guide.

**To Service Antenna Blade**

1. Disconnect power and open the door.
2. Remove the clip and turn the antenna cover left.
3. Remove antenna cover and the antenna will come with it.

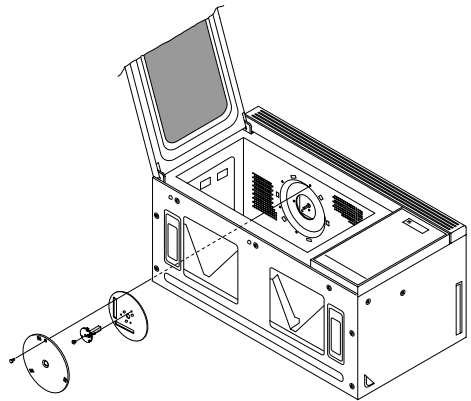

**To Service Antenna Motor**

1. Disconnect power and remove grille screws(2).
2. Remove grille and the bracket duct upper screws(1).
3. Remove the bracket duct upper and disconnect the antenna motor wire.
4. Remove antenna motor screws(2) and pull the antenna motor .

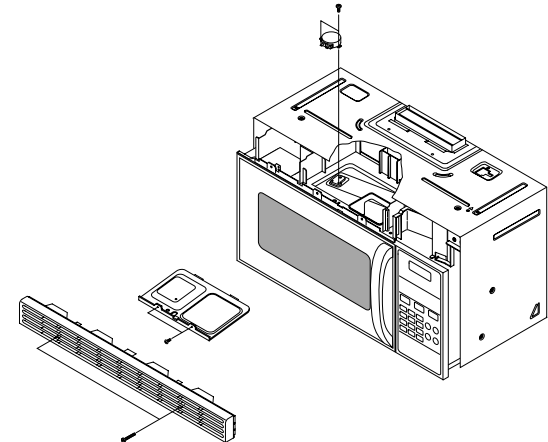

316137217

**To Service Turntable Motor**

1. Disconnect power and remove bottom plate screws(7).
2. Remove bottom plate and disconnect the turntable motor wire.
3. Remove turntable motor screws(2) and pull the turntable motor.

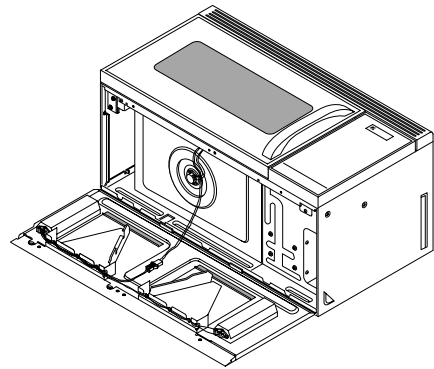

**KEY PANEL TEST**

If necessary the key panel pads can be verified by a continuity test. For ease of handling the key panel should be removed and placed on a flat surface.

**RIBBON**

PAD	CONN.	PAD	CONN.
ADD 30SEC	4-11	CLEAR	3-12
TEMPCOOK/ROAST	3-15	AMP/PM	9-13
BEVERAGE	9-11	CLOCK	7-13
POWER LEVEL	3-14	TIMER	4-13
DEFROST	4-15	START	3-11
BEEPER VOLUME	9-12	HELP	4-12
AUTO NITE LIGHT	6-12	POTATO	6-10
AGROUND MEATS	3-10		1
SURFACE LIGHT	7-12		2
VENT FAN	8-12		3
TURNTABLE	5-12		4
REMINDER	5-13		5
TIME COOK	5-15		6
DELAY START	6-13		7
REHEAT	8-11		8
POPCORN	7-11		9
VEGETABLE	9-10		0

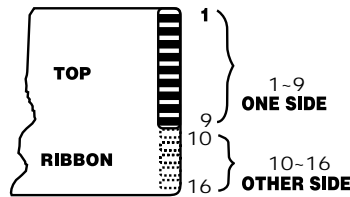

**SMART BOARD**

SMART BOARD is used to serve as an electrical interface between the control and the oven. SMART BOARD is located on the back of the control panel assembly.

The SMART BOARD contains the power relay, vent blower and surface light relays, and other components to perform the proper switching circuits. Several disconnect plugs are also located on the SMART BOARD:

- CON 1 - Ribbon Connector
- CON 2 - Vent Blower Connector
- CON 3 - Primary L.V.T & Main Relay
- CON 4 - Door Sensing & Probe Connector
- CON 5 - Gas Sensor Connector

**• TECHNICAL DATA SHEET •**

Many diagnostic circuit test can be made at the disconnect plugs. (Refer to diagnosis flow chart and simplified schematic in mini-manuals.)

**VARISTOR REPLACEMENT**

1. Clip old varistor wires at Green varistor body (leaving two short leads).
2. Replacement varistor has push-on terminals connected.(WB27 x 5230)
3. Plug new varistor on the cut leads. Check for tightness.

**SENSOR COOKING**

The Sensor Cooking function uses a special gas sensor which detects both humidity (steam) and hydrocarbons (food odors) during the cooking process. The sensor is a plug-in device located in the vent area at the top left hand corner of the cavity behind the grille.

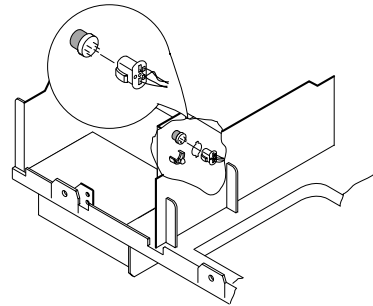

**SENSOR COOKING TEST**

1. Place 1/3 cup tap water in oven.
2. Touch **VEGETABLE** the oven starts immediately.
3. Control Beeps and shuts off.
4. Touch **CLEAR/OFF**

- A) Test OK - Normal
- B) Test Fails - Check Sensor
- C) Test Fails - See Sensor Test Below

**SENSOR TEST (QUICK TEST)**

1. With 2 fingers touch and hold the following pads at the same time : [7] and [8]
2. Observe diagnostic number in display (numbers approximate)
  - 15-185 (Normal-verify with "detection test")
  - 213 or Higher (sensor failed to open, sensor unplugged, wiring or smart board)
  - Less than 6 (sharded sensor, or smart board).

**NOTE :** Only heater terminals (H) can be checked with ohmmeter (30Ω).

**CAUTION :** DO NOT ATTEMPT TO CHECK SENSORTERMINALS (CAN DAMAGE SENSOR).

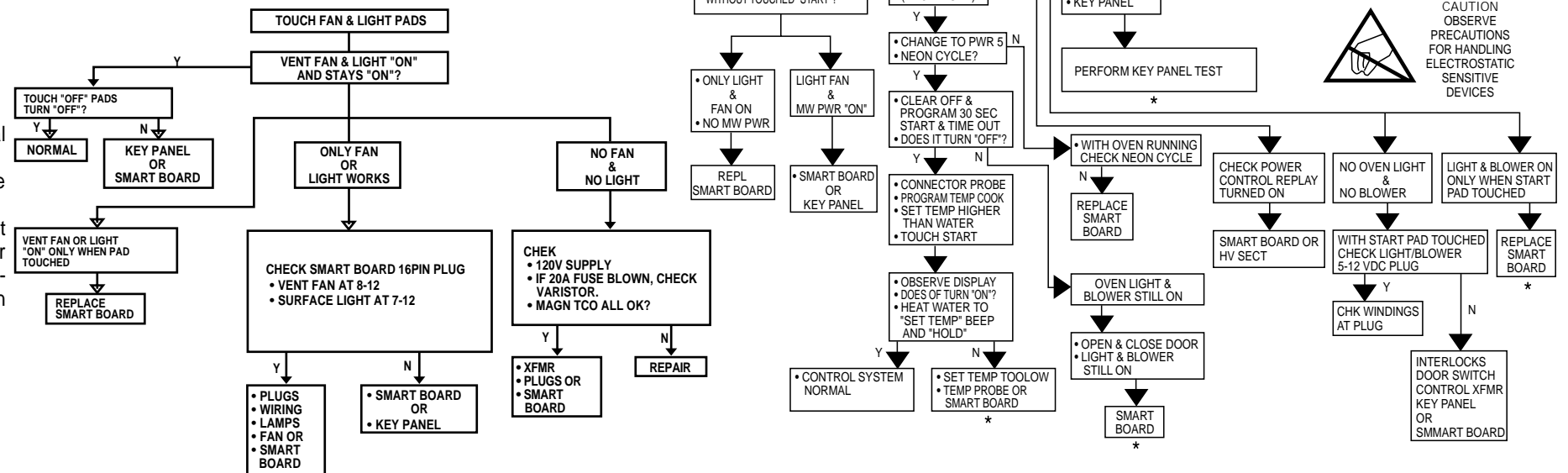

**CONTROL PERFORMANCE TEST**

- Set Clock-Touch clock pad, enter time of day, touch start pad.
  - Alternately touch each function pad and enter time or temperature, selection for the function - also change power levels.
  - Touch Clear-Off after each function test to clear that funtion.
  - Repeat procedure for each function to exercise each pad.
  - Control and display should respond to each entry.
  - Display should revert to Time-Of-Day after each Clear-Off.
- Refer results to Diagnosis Flow Chart.

**CAPACITOR AND DIODE**

The high voltage capacitor and diode can be serviced through Control Panel after removing grille.

**MAGNETRON, MAGNETRON FAN, VENT BLOWER AND POWER TRANSFORMER**

Oven must be removed from wall.

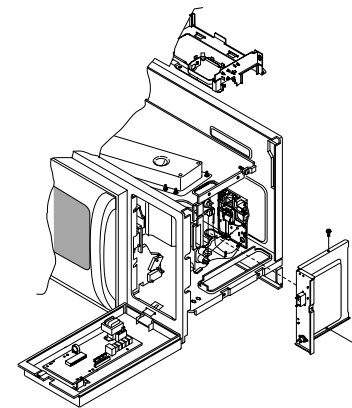

**REMOVING OVEN FROM WALL (2 PEOPLE REQUIRED)**

Oven is hooked on metal tabs at bottom of wall mounting plate and fastened to cabinet by (3) top cabinet bolts.

**CAUTION :** Oven weights 73 lbs. Requires 2 people for removal.

1. Disconnect Power Cord, Top vented models - disconnect duct and remove damper assembly.
2. Remove (3) top cabinet bolts.
3. Pull unit forward slowly providing adequate support to prevent dropping unit during removal of last top cabinet bolt.

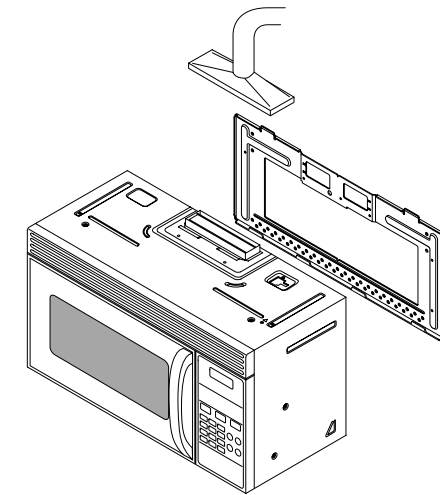

**MICROWAVE OVEN HOODS**

**IMPORTANT SAFETY NOTICE**  
THIS INFORMATION IS INTENDED FOR USE BY INDIVIDUALS POSSESSING ADEQUATE BACKGROUNDS OF ELECTRICAL ELECTRONIC AND MECHANICAL EXPERIENCE. ANY ATTEMPT TO REPAIR A MAJOR APPLIANCE MAY RESULT IN PERSONAL INJURY AND PROPERTY DAMAGE. THE MANUFACTURER OR SELLER CANNOT BE RESPONSIBLE FOR THE INTERPRETATION OF THIS INFORMATION, NOR CAN IT ASSUME ANY LIABILITY IN CONNECTION WITH ITS USE.

DISCONNECT POWER BEFORE SERVICING  
IMPORTANT • RECONNECT ALL  
GROUNDING DEVICES

ALL PARTS OF THIS APPLIANCE CAPABLE OF CONDUCTING ELECTRICAL CURRENT ARE GROUNDED. IF GROUNDING WIRES, SCREWS, STRAPS, CLIPS, NUTS OR WASHERS USED TO COMPLETE A PATH TO GROUND ARE REMOVED FOR SERVICE, THEY MUST BE RETURNED TO THEIR ORIGINAL POSITION AND PROPERLY FASTENED.

### PRECAUTIONS TO BE OBSERVED BEFORE AND DURING SERVICING TO AVOID POSSIBLE EXPOSURE TO EXCESSIVE MICROWAVE ENERGY

- MICROWAVE EMISSION CHECK SHOULD BE PERFORMED PRIOR TO SERVICING IF THE OVEN IS OPERATIVE.**
- DO NOT OPERATE OR ALLOW THE OVEN TO BE OPERATED WITH THE DOOR OPEN.**
- IF THE OVEN OPERATES WITH THE DOOR OPEN: 1) INSTRUCT THE USER NOT TO OPERATE THE OVEN AND 2) CONTACT THE MANUFACTURER AND THE CENTER FOR DEVICES AND RADIOLIGICAL HEALTH IMMEDIATELY.**
- MAKE THE FOLLOWING SAFETY CHECKS ON ALL OVENS TO BE SERVICED BEFORE ACTIVATING THE MAGNETRON OR OTHER MICROWAVE SOURCE, AND MAKE REPAIRS AS NECESSARY:**
  - INTERLOCK OPERATION**
  - PROPER DOOR CLOSING**
  - SEAL AND SEALING SURFACES (ARCING, WEAR, AND OTHER DAMAGE)**
  - DAMAGE TO OR LOOSENING OF HINGES AND LATCHES**
  - EVIDENCE OF DROPPING OR ABUSE**
- BEFORE TURNING ON MICROWAVE POWER FOR ANY SERVICE TEST OR INSPECTION WITHIN THE MICROWAVE GENERATING COMPARTMENTS, CHECK THE MAGNETRON, WAVE GUIDE OR TRANSMISSION LINE, AND CAVITY FOR PROPER ALIGNMENT, INTEGRITY, AND CONNECTIONS.**

316137217

**F. ANY DEFECTIVE OR MISADJUSTED COMPONENTS IN THE INTERLOCK, MONITOR, DOOR SEAL, AND MICROWAVE GENERATION AND TRANSMISSION SYSTEMS SHALL BE REPAIRED, REPLACED, OR ADJUSTED BY PROCEDURES DESCRIBED IN THIS MANUAL BEFORE THE OVEN IS RELEASED TO THE OWNER.**

**G. A MICROWAVE LEAKAGE CHECK TO VERIFY COMPLIANCE WITH THE FEDERAL PERFORMANCE STANDARD SHOULD BE PERFORMED ON EACH OVEN PRIOR TO RELEASE TO THE OWNER.**

**GROUNDING SPECIFICATIONS**

Leakage Current 0.5 mA. (Max.)  
Ground Path Resistance 0.14 (MAX.)

**INSTALLATION REQUIREMENTS**

**ELECTRICAL**  
Power Source 120 VAC, 60 Hz.  
Line Current 13.5 Amps. (1580Watts)  
Over Current Protection 15-20 Amps \*  
\* Requires 120 Volt, 15-20 Amp. parallel, grounded separate circuit.  
Working Voltage 105-130 VAC.

**MICROWAVE LEAKAGE TEST**

- Place 275 ml. water in 600 ml. beaker (WB64 X 5010)
- Place beaker in center of oven shelf.
- Set meter to 2450 MHz scale.
- Turn oven "on" for 5 minute test.
- Hold probe perpendicular to surface being tested and scan surfaces at rate of one inch/sec.  
Test the following areas:
  - Entire perimeter of door and control panel
  - Viewing surface of door window
  - Exhaust vents
- Maximum leakage 4 MW/CM<sup>2</sup>
- Record data on service invoice and microwave leakage report.

**NOTE :** Maximum allowable leakage is 5 MW/CM<sup>2</sup>. 4 MW/CM<sup>2</sup> is used to allow for measurement and meter accuracy.

Inform the manufacturer of any oven found to have emission in excess of 5 MW/CM<sup>2</sup>. Make repairs to bring the unit into compliance at no cost to owner and try to determine cause. Instruct owner not to use oven until it has been brought into compliance.

**HIGH VOLTAGE CAPACITOR**

The high voltage capacitor has an internal shunt resistor to automatically discharge the capacitor when the oven turns "off". Under normal operation the capacitor should fully discharge within 30 seconds.

**WARNING!**

Always be certain the capacitor is discharged before servicing. Mechanically discharge by placing an insulated handle screwdriver between the diode connection of the capacitor and oven chassis ground.

**NOTE :** Use screw head close to capacitor to insure ground metal contact.

**• TECHNICAL DATA SHEET •****STANDARD TEST LOAD**

Test load will be 1 liter (1000ML) of water with an initial temperature of 59°-75° in a 1000 ml beaker (WB64 X 0073 or Robonar 14882).

**PERFORMANCE TEST**

- Record initial water temperature.
- Run at high power for 2:03.
- Record end water temperature.

The minimum difference between the initial and ending temperature should be:  
30° @ 120 V

**INTERLOCKS(DOOR Latch Switches)**

Interlocks are designed as follows:

- Primary - Bottom switch operated by bottom latch pawl connected to line (L) leg.

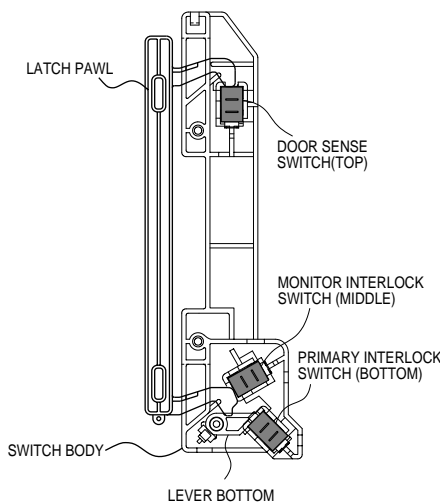
**HOW TO TEST INTERLOCKS**

Disconnect power, open control panel, and discharge capacitor.

Primary

- Check Continuity of Com and N.O.:
  - Door Closed - 0 Ω
  - Door Open - ∞ Ω

**MONITOR SWITCH**

The monitor switch is located between the top and bottom interlocks. The monitor switch is operated indirectly by the bottom latch pawl.

**HOW TO TEST MONITOR**

- Disconnect power, open control panel, and discharge capacitor.
- Disconnect monitor switch leads, and test at terminals:
  - Door Closed - ∞ Ω
  - Door Open - 0 Ω
- Reconnect switch wiring.
- Test Circuit Operation:
  - Connect temporary jumper across relay contacts and primary switch to simulate shorted switch contacts. Locate convenient connections in circuit to be certain COM and N.O. terminals are used.
  - Connect OHM meter (Low Scale) across the two line terminals of appliance power cord.  
Continuity must show:
    - Door Close - Some Ω
    - Door Open - 0 Ω

- Remove 20 Amp. Fuse - Circuit must open (∞ Ohms). If not, check wiring of monitor and interlock circuits.

- Warning: After test, remove temporary jumpers and reconnect monitor switch leads.

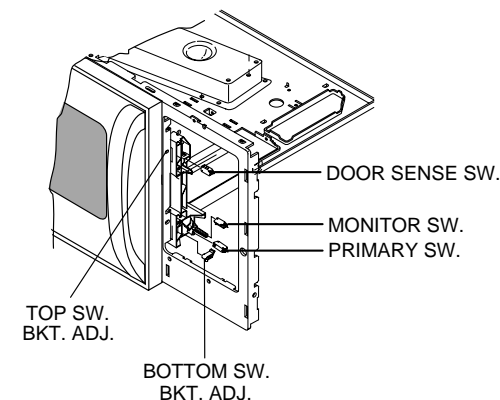
**FUSE**

**WARNING! When 20 Amp. fuse is blown due to operation of the monitor switch, the monitor switch must be replaced. Also replace relays and / or interlock switches when continuity check shows contacts shorted.**

**HOW TO ADJUST INTERLOCKS**

The switch housing is adjustable for door fit and switch operation.

- Disconnect power, open control panel, and discharge capacitor.
- Loosen switch housing mounting screw at enlarged hole in vertical flange.
- Adjust each switch housing for proper switch operation, and door fit. Retighten screws.
- IMPORTANT - CHECK FOR MICROWAVE LEAKAGE AFTER ANY ADJUSTMENT.**

**CAUTION !**

When safety interlocks and monitor switches are repaired or replaced, check microwave leakage and distance between door and cavity of micro-wave as described below.

- Use a piece of paper 0.02 inch thick, 1 inch wide and 4 inches long (a dollar bill folded in half twice lengthwise is about this size).
- Open the door and place the paper between the door and front frame of the oven cavity.
- Close the door to capture it between the door and the cavity front frame.
- Draw the paper from between the door and cavity (check at bottom and sides also) if there is resistance to the removal of the paper then the distance is correct.
- Perform microwave leakage check, if leakage does not exceed 4 MW/CM<sup>2</sup> it is performing properly.

**TO PREVENT ELECTRICAL SHOCK, USE EXTREME CAUTION WHEN DIAGNOSING OVEN WITH OUTER CASE REMOVED AND POWER "ON". THE HIGH VOLTAGE SECTION OF THE POWER SUPPLY, INCLUDING FILAMENT LEADS IS 4000 VOLTS POTENTIAL WITH RESPECT TO GROUND.**

**AUTOMATIC FAN FEATURE**

Exhaust fan turns "ON" (low speed) automatically during some surface unit heavy use conditions. (Cannot be turned off manually - will turn off automatically.) May stay on up to 15 mins. after range and lower oven controls are turned off.

**HOOD THERMOSTAT**

Single pole thermostat mounted on R.H. side duct in control compartment. Contacts close at approx. 158°F.

**BOTTOM THERMOSTAT**

Single pole thermostat mounted on base plate. Contacts open at approx. 248 °F

**DOOR ASSEMBLY**

The door assembly is serviceable as an assembly or with parts.

**ADJUSTMENT (Alignment with Control Panel)**

Remove top grille and bottom cover. Loosen top and bottom hinge screws to adjust. Retighten screws.

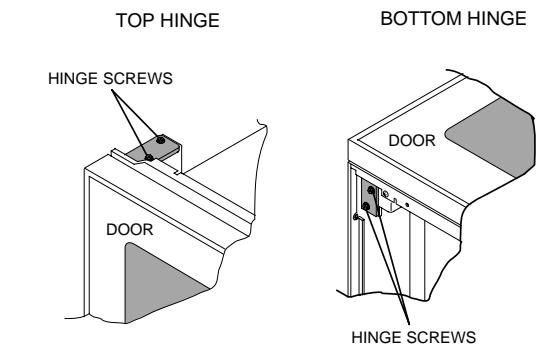
**MICROWAVE LEAKAGE TEST**

**A microwave leakage test must be performed any time a door is removed, replaced, disassembled, or adjusted for any reason. THE MAXIMUM LEAKAGE IS 4 MW/CM<sup>2</sup>.**

# SCHEMATIC DIAGRAM

WARNING

POWER MUST BE DISCONNECTED  
BEFORE SERVICING THIS APPLIANCE

OTR7  
MODEL NO. : GLMV168,PLMV168

COLOR	SYMBOL
GRAY	GR
WHITE	W
BLACK	B
RED	R
BLUE	BL
ORANGE	O
YELLOW	Y
GREEN	G
PINK	P
AZURE	A
VIOLET	V

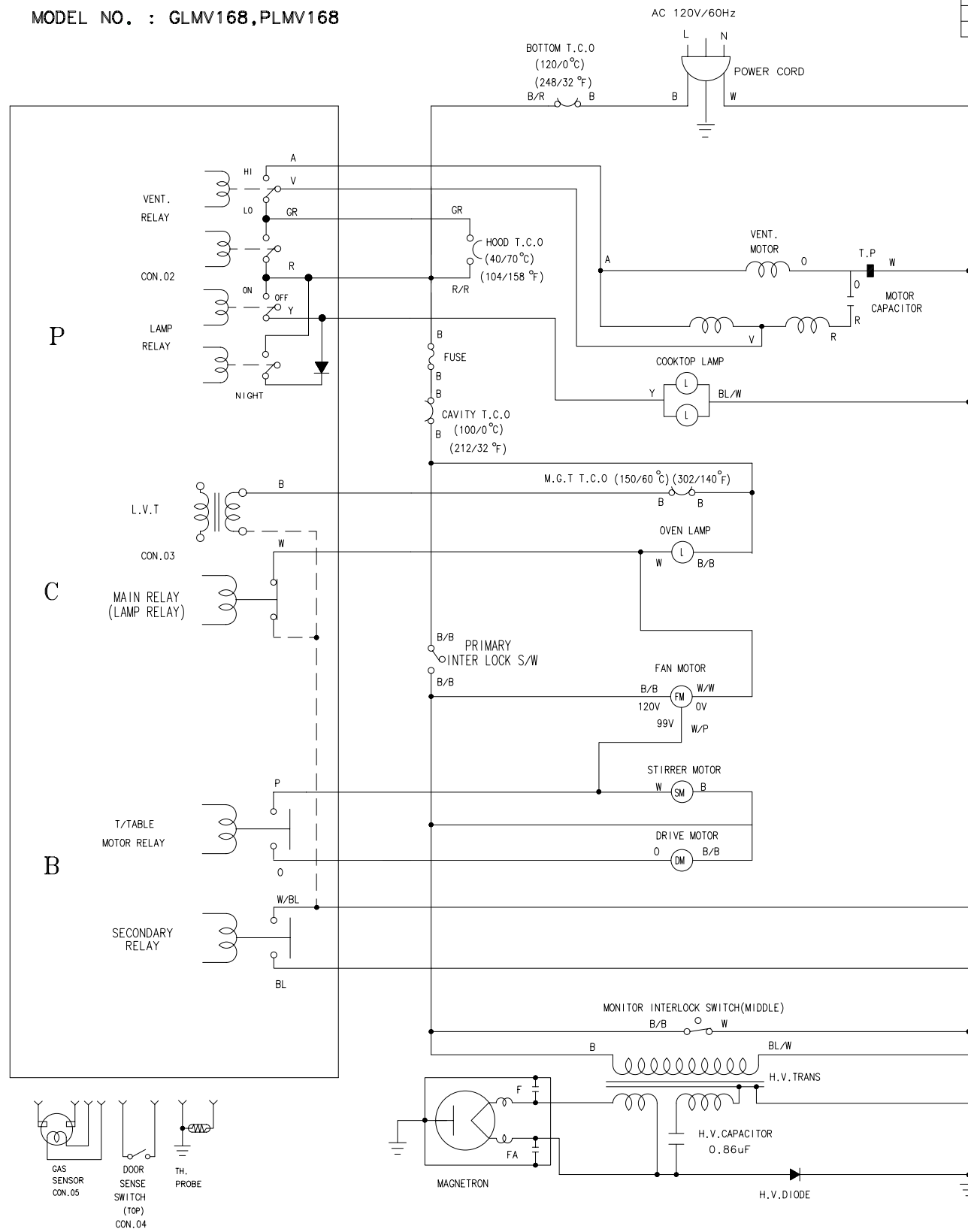

NOTE: DOOR IS OPEN.  
PROBE SWITCH IS CLOSED.

# WIRING DIAGRAM

WARNING

POWER MUST BE DISCONNECTED  
BEFORE SERVICING THIS APPLIANCE

OTR7  
MODEL NO. : GLMV168,PLMV168

COLOR	SYMBOL
GRAY	GR
WHITE	W
BLACK	B
RED	R
BLUE	BL
ORANGE	O
YELLOW	Y
GREEN	G
PINK	P
AZURE	A
VIOLET	V

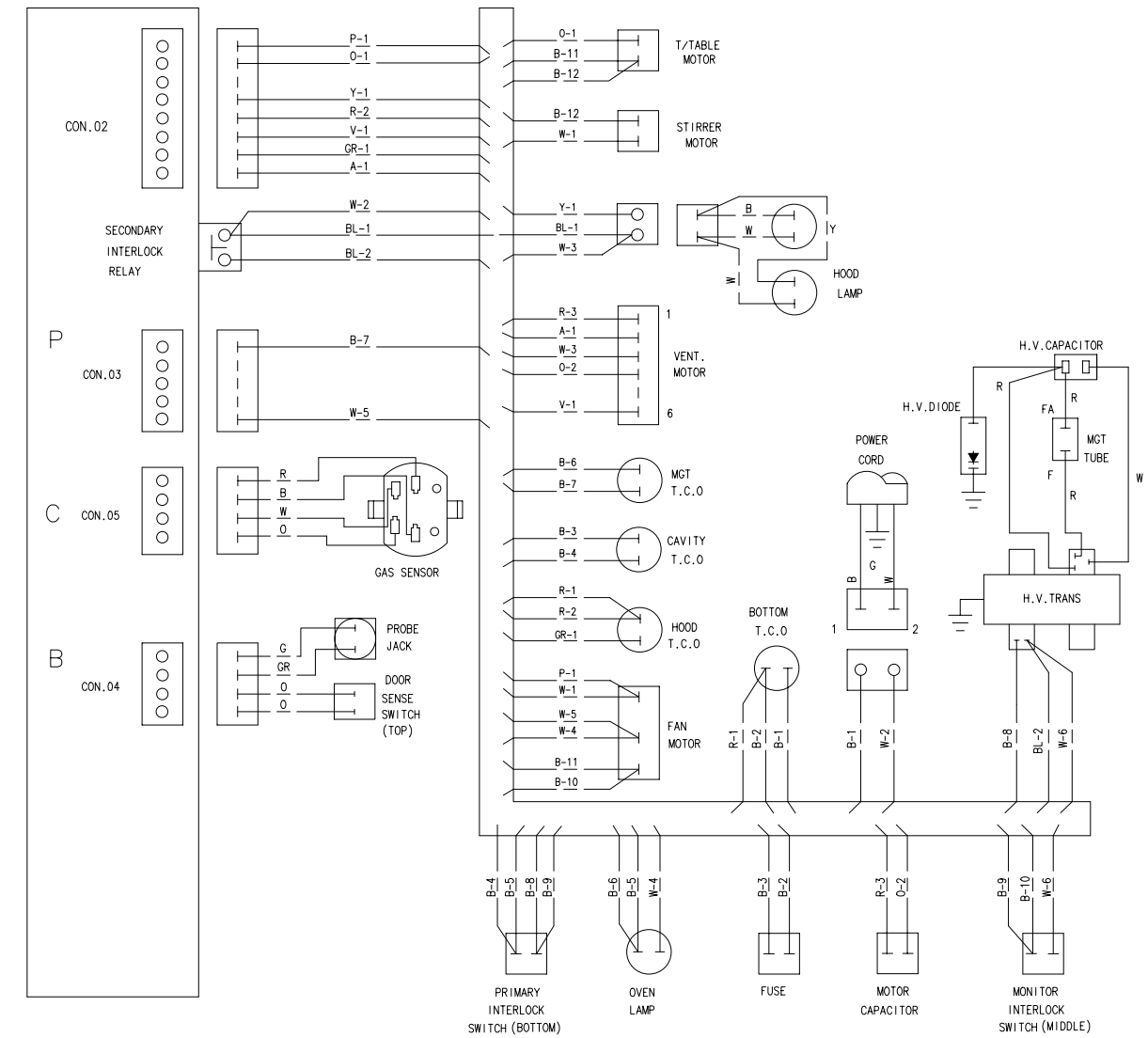

NOTE: FOR SERVICING REPLACEMENT USE 16GA, 105 °C  
THERMOPLASTIC COVERED WIRE EXCEPT FOR  
HIGH VOLTAGE LEADS OR AS NOTED ON SPECIAL LEADS.

Printed in Korea