

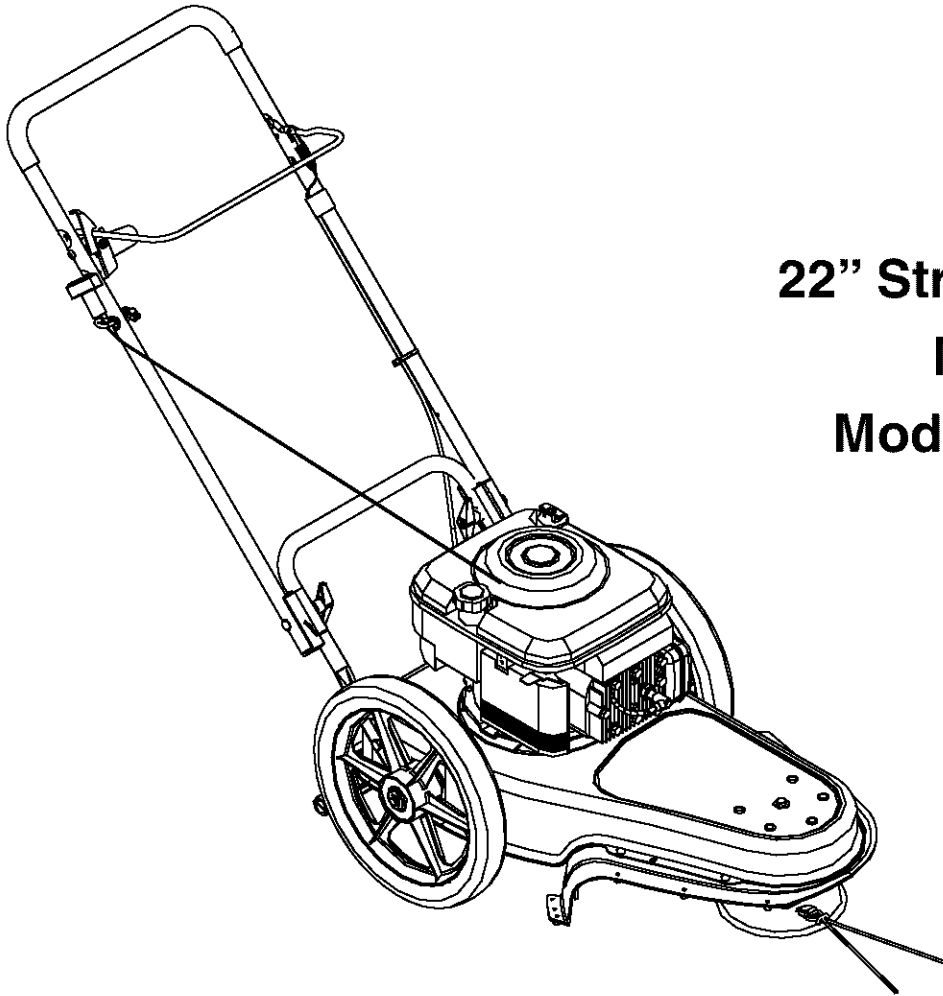

OPERATOR'S MANUAL



**22" String Trimmer
Mower
Model Number
258**

IMPORTANT: READ SAFETY RULES AND INSTRUCTIONS CAREFULLY

Warning: This unit is equipped with an internal combustion engine and should not be used on or near any unimproved forest-covered, brush-covered or grass-covered land unless the engine's exhaust system is equipped with a spark arrester meeting applicable local or state laws (if any). If a spark arrester is used, it should be maintained in effective working order by the operator. In the State of California the above is required by law (Section 4442 of the California Public Resources Code). Other states may have similar laws. Federal laws apply on federal lands. A spark arrester for the muffler is available through your nearest engine authorized service dealer or contact the service department, P.O. Box 361131 Cleveland, Ohio 44136-0019.

TROY-BILT LLC P.O. BOX 361131 CLEVELAND, OHIO 44136-0019

PRINTED IN U.S.A.

FORM NO. 769-00009C

(11/02)

TABLE OF CONTENTS

Content	Page
Important Safe Operation Practices.....	3
Slope Gauge.....	6
Assembling Your String Trimmer Mower.....	7
Know Your String Trimmer Mower.....	8
Operating Your String TrimmerMower.....	9
Making Adjustments.....	9
Maintaining Your String TrimmerMower.....	10
Troubleshooting.....	13
Parts List.....	14

FINDING MODEL NUMBER

This Operator's Manual is an important part of your new string trimmer mower. It will help you assemble, prepare and maintain the unit for best performance. Please read and understand what it says.



Before you start assembling your new equipment, please locate the model plate on the equipment and copy the information from it in the space provided below. The information on the model plate is very important if you need help from our Customer Support Department or an authorized dealer.

- You can locate the model number by looking down at the rear of the string trimmer mower. A sample model plate is explained below. For future reference, please copy the model number and the serial number of the equipment in the space below.

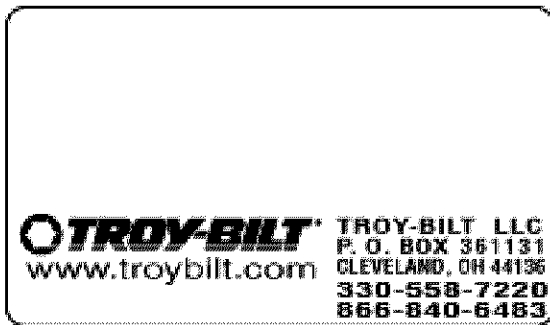

Copy the model number here: _____

Copy the serial number here: _____

ENGINE INFORMATION

The engine manufacturer is responsible for all engine-related issues with regards to performance, power-rating, specifications, warranty and service. Please refer to the engine manufacturer's Owner's/Operator's Manual packed separately with your unit for more information.

CALLING CUSTOMER SUPPORT

If you have difficulty assembling this product or have any questions regarding the controls, operation or maintenance of this unit, please call the Customer Support Department.



Call 1- (330) 558-7220 or 1- (866)-840-6483 to reach a Customer Support representative. Please have your unit's model number and serial number ready when you call. See previous section to locate this information. You will be asked to enter the serial number in order to process your call.

For more details about your unit, visit our website at www.troybilt.com

SECTION 1: IMPORTANT SAFE OPERATION PRACTICES



WARNING: This symbol points out important safety instructions which, if not followed, could endanger the personal safety and/or property of yourself and others. Read and follow all instructions in this manual before attempting to operate this machine. Failure to comply with these instructions may result in personal injury. When you see this symbol - **heed its warning.**

WARNING: Engine Exhaust, some of its constituents, and certain vehicle components contain or emit chemicals known to State of California to cause cancer and birth defects or other reproductive harm.

DANGER: This machine was built to be operated according to the rules for safe operation in this manual. As with any type of power equipment, carelessness or error on the part of the operator can result in serious injury. This machine is capable of amputating hands and feet and throwing objects. Failure to observe the following safety instructions could result in serious injury or death.

General Operation

1. Read this operator's manual carefully in its entirety before attempting to assemble this machine. Read, understand, and follow all instructions on the machine and in the manual(s) before operation. Be completely familiar with the controls and the proper use of this machine before operating it. Keep this manual in a safe place for future and regular reference and for ordering replacement parts.
2. This machine is a precision piece of power equipment, not a plaything. Therefore, exercise extreme caution at all times. Your unit has been designed to perform one job: to cut vegetation and grass. Do not use it for any other purpose.
3. Never allow children under 14 years old to operate this machine. Children 14 years old and over should read and understand the operation instructions and safety rules in this manual and should be trained and supervised by an adult. Only responsible individuals who are familiar with these rules of safe operation should be allowed to use this machine.
4. Thoroughly inspect the area where the equipment is to be used. Remove all stones, sticks, wire, bones, toys, and other foreign objects which could be tripped over or picked up and thrown by the string trimmer mower in any direction which could cause serious personal injury to the operator or any others allowed in the area. Plan your trimming pattern to avoid discharge of material toward building, walls, roads, sidewalks, bystanders and the like. To help avoid trimmer line contact or a thrown object injury, keep children, bystanders, and helpers at least 75 feet from the string trimmer mower while it is in operation. Stop the string trimmer mower if anyone enters the area.
5. Always wear safety glasses or safety goggles during operation or while performing an adjustment or repair, to protect eyes from foreign objects that may be thrown from the machine in any direction.
6. Wear sturdy, rough-soled work shoes and close-fitting slacks and shirts. Shirts and pants that cover the arms and legs and steel-toed shoes are recommended. Never operate a unit in bare feet, sandals, slippery or light weight (e.g. canvas) shoes.
7. Do not put hands or feet near or under rotating parts. Keep clear of discharge area at all times as the rotating trimmer head and lines can cause injury.
8. Never pull the string trimmer mower back toward you while you are walking. If you must back the string trimmer mower away from a wall or obstruction first look down and behind, and then follow these steps:
 - a. Step back from the string trimmer mower to fully extend your arms.
 - b. Be sure you are well balanced with sure footing.
 - c. Pull the string trimmer mower back slowly, no more than half way toward you.
 - d. Repeat these steps as needed.
5. Do not operate the string trimmer mower while under the influence of alcohol or drugs.
6. The trimmer head control handle is a safety device. Never attempt to bypass its operation. Doing so makes the safety device inoperative and may result in personal injury through contact with the rotating head or lines. The trimmer head control handle must operate easily in both directions and automatically return to the disengaged position when released.
7. Disengage the trimmer head before starting the engine.
8. Never operate the string trimmer mower in wet grass. Always be sure of your footing. A slip and fall can cause serious personal injury. If you feel you are losing your footing, release the trimmer head control handle immediately and the trimmer head will stop rotating within a few seconds.

9. Trim or mow only in daylight or good artificial light. Walk never run.
10. Stop the trimmer head when crossing gravel drives, walks or roads.
11. If the equipment should start to vibrate abnormally, stop the engine and check immediately for the cause. Vibration is generally a warning of trouble.
12. Shut the engine off and wait until the trimmer head comes to a complete stop before replacing trimmer line, making any adjustment or repairs. The trimmer head continues to rotate for a few seconds after the engine is shut off. Never place any part of the body in the trimmer head area until you are sure the blade has stopped rotating.
13. Never operate the string trimmer mower without proper shields, guards, trimmer head control handle or other safety protective devices in place and working. Never operate the string trimmer mower with damaged safety devices. Failure to do so, can result in personal injury.
14. Muffler and engine become hot and can cause a burn. Do not touch.
15. Only use parts and accessories made for this string trimmer mower by the manufacturer. Failure to do so, can result in personal injury.
16. If situations occur which are not covered in this manual, use care and good judgment. Contact your dealer for assistance. Telephone 1-800-800-7310 for the name of your nearest dealer.

Slope Operation

Slopes are a major factor related to slip and fall accidents which can result in severe injury. Operation on slopes requires extra caution. If you feel uneasy on a slope, do not trim or mow it. For your safety, use the slope gauge included as part of this manual to measure slopes before operating this unit on a sloped or hilly area. If the slope is greater than 15 degrees, do not trim or mow it.

Do:

1. Trim or mow across the face of slopes; never up or down. Exercise extreme caution when changing direction on slopes.
2. Watch for holes, ruts, hidden objects, or bumps. Tall grass can hide obstacles.
3. Always be sure of your footing. A slip and fall can cause serious personal injury. If you feel you are losing your balance, release the trimmer head control handle immediately, and the trimmer head will stop rotating within a few seconds.

Do Not:

1. Do not trim or mow near drop-offs, ditches or embankments. The operator could lose footing or balance.
2. Do not trim or mow slopes greater than 15 degrees as shown on the slope gauge on page 6.

3. Do not trim or mow on wet grass. Unstable footing could cause slipping.

Children

Tragic accidents can occur if the operator is not alert to the presence of children. Children are often attracted to the string trimmer mower and the trimming or mowing activity. They do not understand the dangers. Never assume that children will remain where you last saw them.

1. Keep children out of the trimming or mowing area and under the watchful care of a responsible adult other than the operator.
2. Be alert and turn string trimmer mower off if a child enters the area.
3. Before and while moving backwards, look behind and down for small children.
4. Use extreme care when approaching blind corners, shrubs, trees, or other objects that may obscure your vision of a child who may run into the string trimmer mower.
5. Keep children away from hot or running engines. They can suffer burns from a hot muffler.
6. Never allow children under age 14 to operate a string trimmer mower. Children 14 years of age and over should read and understand the operation instructions and safety rules in this manual and should be trained and supervised by an adult.

Service

Safe Handling Of Gasoline:

To avoid personal injury or property damage use extreme care in handling gasoline. Gasoline is extremely flammable and the vapors are explosive. Serious personal injury can occur when gasoline is spilled on yourself or your clothes which can ignite. Wash your skin and change clothes immediately.

1. Use only an approved gasoline container.
2. Extinguish all cigarettes, cigars, pipes, and other sources of ignition.
3. Never fuel machine indoors because flammable vapors will accumulate in the area.
4. Never remove gas cap or add fuel while the engine is running. Allow engine to cool at least two minutes before refueling.
5. Never over fill fuel tank. Fill tank to no more than 1/2 inch below bottom of filler neck to provide space for fuel expansion.
6. Replace gasoline cap and tighten securely.
7. If gasoline is spilled, wipe it off the engine and equipment. Move unit to another area. Wait 5 minutes before starting the engine.
8. Never store the machine or fuel container inside where there is an open flame, spark, or pilot light as on a gas water heater, space heater, furnace, clothes dryer or other gas appliances.
9. To reduce fire hazard, keep the string trimmer mower free of grass, leaves, or other debris build-

up. Clean up oil or fuel spillage and remove any fuel soaked debris.

10. Allow mower to cool at least 5 minutes before storing.

General Service:

1. Never run an engine indoors or in a poorly ventilated area. Engine exhaust contains carbon monoxide, an odorless and deadly gas.
2. Before cleaning, repairing, or inspecting, make certain the trimmer head and all moving parts have stopped. Disconnect the spark plug wire and ground against the engine to prevent unintended starting.
3. Check the trimmer head and engine mounting bolts at frequent intervals for proper tightness. Also, visually inspect trimmer head for damage. Replace with the original equipment manufacturer's (OEM) parts only, listed in this manual. "Use of parts which do not meet the original equipment specifications may lead to improper performance and compromise safety!"
4. Keep all nuts, bolts, and screws tight to be sure the equipment is in safe working condition.
5. Never tamper with safety devices. Check their proper operation regularly.
6. After striking a foreign object, stop the engine,

disconnect the spark plug wire and ground against the engine. Thoroughly inspect the string trimmer mower for any damage. Repair the damage before starting and operating.

7. Never attempt to replace the trimmer line or make a cutting height adjustment while the engine is running.
8. Never use other lengths, diameters, or materials as trimmer line. Doing so can result in personal injury.
9. Trimmer head components, guards, and shields are subject to wear and damage which could expose moving parts or allow objects to be thrown. For safety protection, frequently check components and replace immediately with original equipment manufacturer's (OEM) parts only, listed in this manual. "Use of parts which do not meet the original equipment specifications may lead to improper performance and compromise safety!"
10. Do not change the engine governor setting or overspeed the engine.
11. Maintain or replace safety and instruction labels, as necessary.
12. Observe proper disposal laws and regulations. Improper disposal of fluids and materials can harm the environment.



WARNING - YOUR RESPONSIBILITY: Restrict the use of this power machine to persons who read, understand and follow the warnings and instructions in this manual and on the machine.

NOTE: Not all safety labels shown may apply to your string trimmer mower.

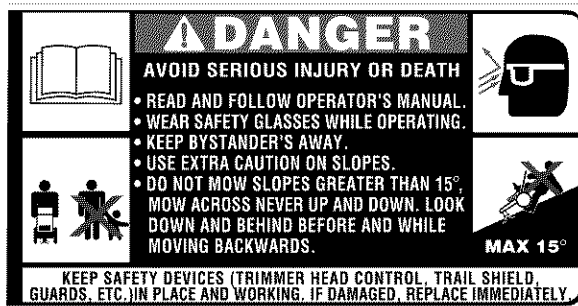

SECTION 2: SLOPE GAUGE

Use this page as a guide to determine slopes where you may not operate safely. Do not operate your lawn mower or string trimmer mower on such slopes.

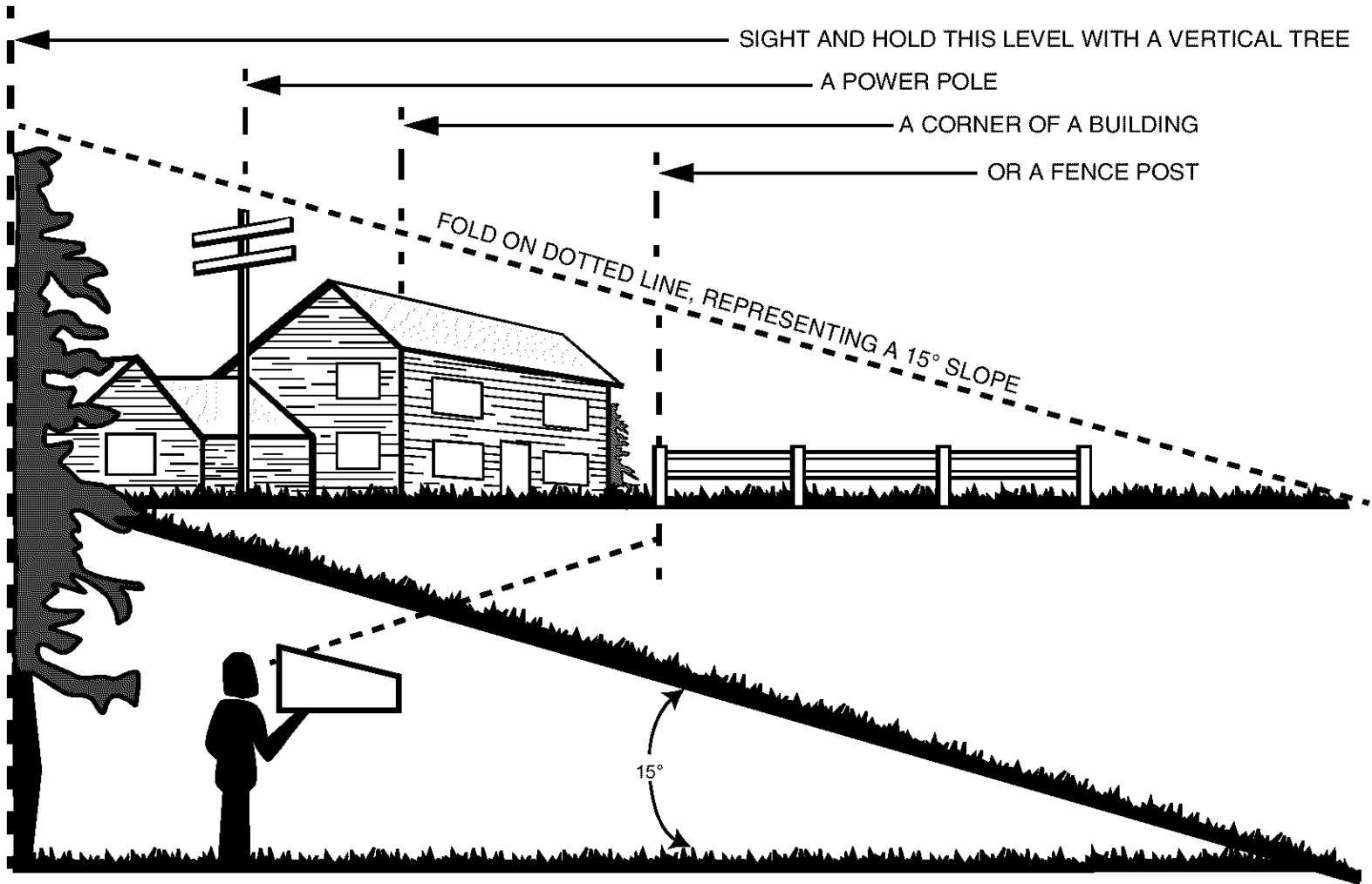

WARNING

Do not trim or mow on inclines with a slope in excess of 15 degrees (a rise of approximately 2-1/2 feet every 10 feet). A riding mower could overturn and cause serious injury. If operating a walk-behind mower or trimmer on such a slope, it is extremely difficult to maintain your footing and you could slip, resulting in serious injury. Operate riding mowers up and down slopes, never across the face of slopes. Operate walk-behind mowers or trimmers across the face of slopes, never up and down slopes.

SECTION 3: ASSEMBLING YOUR STRING TRIMMER MOWER

IMPORTANT: This unit is shipped without gasoline or oil in the engine. Be certain to service engine with gasoline and oil as instructed in the separate engine manual before operating your mower.

NOTE: Reference to right or left hand side of the string trimmer mower is observed from the operating position.

Removing Unit From Carton

- Remove staples, break glue on top flaps, or cut tape at carton end and peel along top flap to open carton.
- Remove loose parts if included with unit (i.e., operator's manual, safety glasses, etc.)
- Cut along corners, lay carton down flat, and remove packing material.
- Roll or slide unit out of carton and check carton thoroughly for loose parts.

Disconnecting Spark Plug Wire

Before setting up your string trimmer mower, disconnect the spark plug wire from the spark plug and ground to a stud on the engine. See Figure 1.

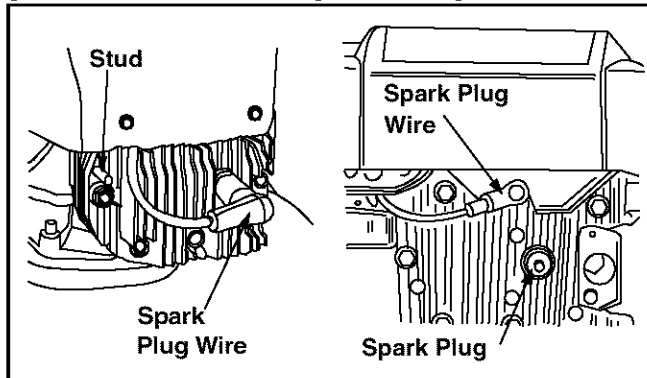

Figure 1

Setting Up Your String Trimmer Mower

- Loosen each wing nut enough to separate the plastic connectors between the upper and lower handle. Gently lift up and pull back on the upper handle to raise the handle toward the operating position. See Figure 2.
- Separate the connectors and position the bottom tip of upper handle connector in front of the bottom tip of lower handle connector. To secure the upper and lower handle, tighten the wing nuts and washers (carriage bolts must be seated properly into the handle and grooves must line up between connectors).

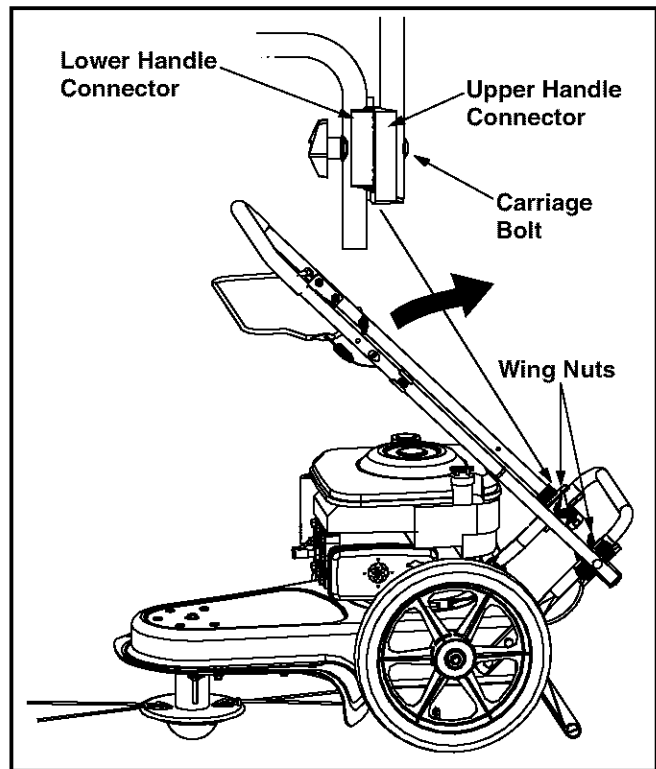

Figure 2

NOTE: If you wish to adjust the height of the upper handle, refer to the Adjustment Section.

- Loosen the wing nut that secures rope guide to handle. With the spark plug wire disconnected and grounded, pull the starter rope out of the engine. Slip the starter rope into the rope guide and tighten the wing nut. See Figure 3.
- Tighten the cable tie on lower left side of handle, making sure the round tab on tie seats nicely into the hole in handle.

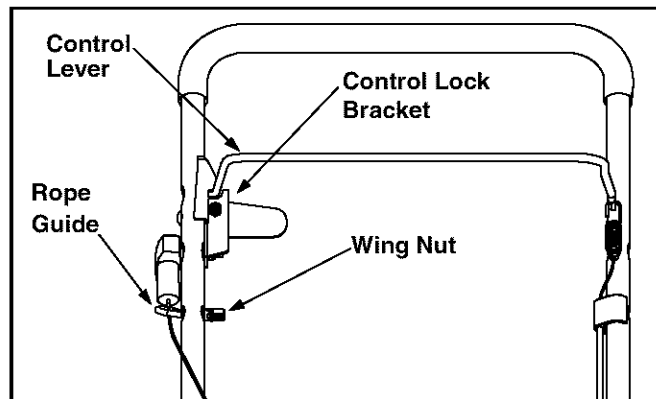

Figure 3

SECTION 4: KNOW YOUR STRING TRIMMER MOWER

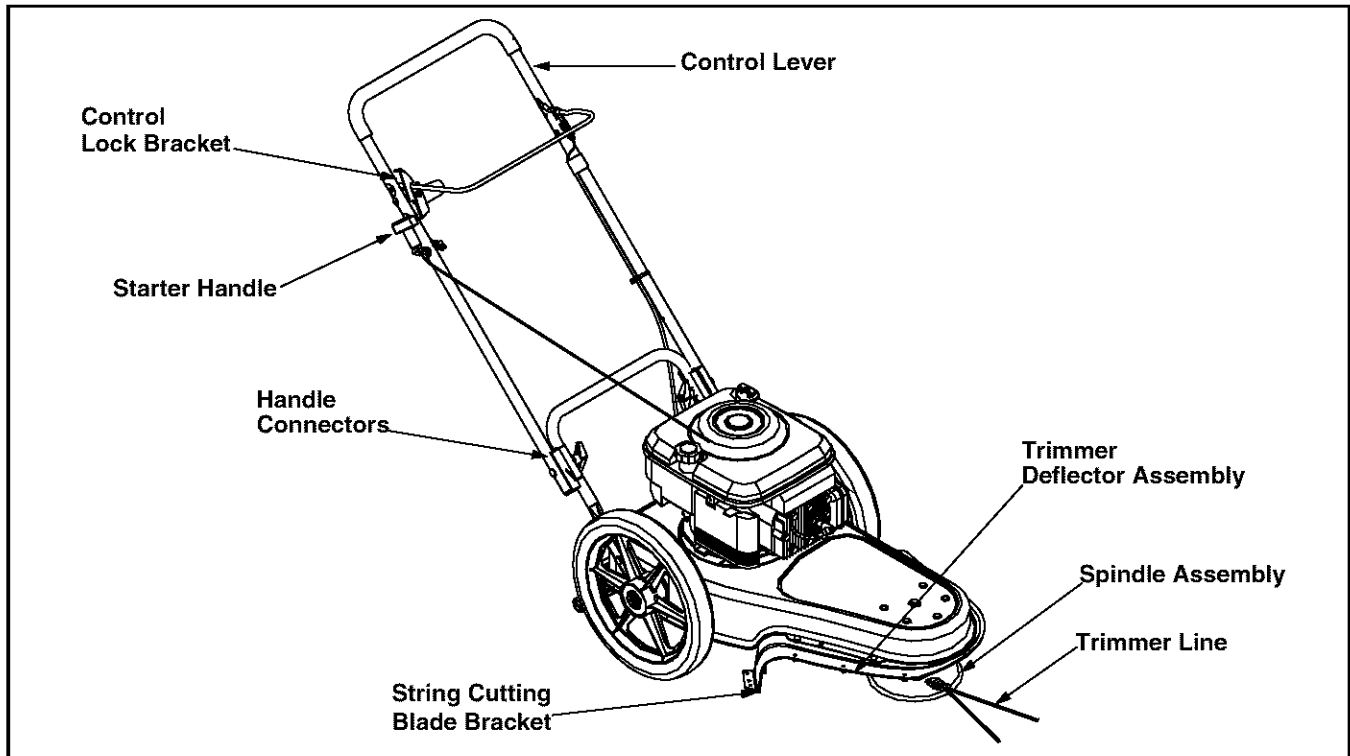

Figure 4

Read this operator's manual and safety rules before operating your string trimmer mower. Compare the illustrations in Figure 4 with your string trimmer mower to familiarize yourself with the location of various controls and adjustments. Save this manual for future reference.

Control Lever

The control lever must be depressed to engage the spindle assembly. See Figure 4.

Control Lock Bracket

The control lock bracket is located on the upper right handle. It is used to keep the spindle assembly disengaged while the engine is running. See Figure 4.

Starter Handle

The starter handle is attached to the right upper handle. Stand behind unit and pull the starter handle to start engine. See Figure 4.

Handle Connectors

The handle connectors are on each side between lower and upper handle. They are used to lock the upper handle in a set position. See Figure 4.

String Cutting Blade Bracket

The string cutting blade bracket is attached to the trimmer deflector assembly. It is used to cut the trimmer line if it is too long. See Figure 4.

Trimmer Deflector Assembly

The trimmer deflector assembly is connected to the trimmer base and it is used to prevent yard debris from being thrown. See Figure 4.

Spindle Assembly

The spindle assembly rotates the trimmer line.

Trimmer Line

The trimmer line is attached to the spindle assembly and it is used to trim grass or weeds.

Throttle Control Lever (Not Shown)

The throttle control lever is located on the engine. It controls the engine's speed and stops the engine. See separate engine manual packed with unit for details.

Engine Controls

See the separate engine manual for the location and function of the controls on the engine.

Stopping Engine

- Release control lever to disengage the spindle assembly and to lock it in the control lock bracket.
- Move throttle control lever to STOP or OFF position.
- Disconnect spark plug wire from spark plug and ground against the engine.

SECTION 5: OPERATING YOUR STRING TRIMMER MOWER



WARNING: Debris thrown from the string trimmer mower can result in foreign objects being thrown into the eyes, which can cause severe eye damage. Always wear safety glasses included with unit or eye shields when operating the string trimmer mower.

Gas And Oil Fill-Up

Service the engine with gasoline and oil as instructed in the separate engine manual packed with your string trimmer mower. Read instructions carefully.



WARNING: Never fill fuel tank indoors with engine running or until the engine has been allowed to cool for at least two minutes after running.

Starting Engine

- Attach spark plug wire to spark plug. Make certain the metal cap on the end of the spark plug is fastened securely over the metal tip on the spark plug. See separate engine operator's manual.
- Before each use, remove any debris from the engine's air intake screen on top of engine. Debris can cause engine to overheat.
- Prime engine as instructed in the separate engine manual packed with your unit.
- Move throttle control lever on engine to FAST or RUN position.
- Make sure control lever is disengaged and locked in bracket.
- Stand behind the string trimmer mower and grasp starter handle and pull rope out slowly until engine reaches start of compression cycle (rope will pull slightly harder at this point). Let the rope rewind slowly. Pull rope with a rapid, continuous, full arm stroke. Keeping a firm grip on the starter handle, let the rope return to the starter slowly. Repeat until engine starts.



WARNING: Never run the engine indoors or in a poorly ventilated area. Engine exhaust contains carbon monoxide, an odorless and deadly gas. Keep hands, feet, hair, and loose clothing away from the trimmer and engine.



WARNING: Do not attempt to bypass the control lever. Doing so could result in serious personal injury or death.

Using Your String Trimmer Mower

- Once the engine is started, release the control lock bracket on the upper right hand side of the handle by pushing it to the right and squeeze the control handle against upper handle to engage spindle assembly.
- The string trimmer mower is designed with a permanent off-set on the left side, in which the trimmer line is off-set from the trimmer base. This allows the operator to trim along a fence, landscaping, or a house without having to make any adjustments to the spindle assembly. Refer to Figure 6.
- If the weeds or grass are tall and thick, operate the string trimmer mower at a slower walking speed.
- With the engine off and spark plug disconnected, clean the underside of the trimmer before and after each use to remove any grass or weed build up.
- If the trimmer lines become too short, approximately half the original length, or worn, it will take longer to complete the job. To change to a new trimmer line see MAINTAINING YOUR STRING TRIMMER MOWER.
- Do not trim on excessively steep slopes. If a slope is difficult to stand on, do not trim. Do not trim on slopes when the ground is slippery or wet. Trim across the face of a slope, not up and down.
- Avoid spindle assembly contact to concrete, asphalt, or gravel.

SECTION 6: MAKING ADJUSTMENTS



WARNING: Do not at any time make any adjustments without first stopping engine and disconnecting spark plug wire.

Handle Adjustment

To adjust position of the upper handle proceed as follows:

- Loosen each wing nut, so the carriage bolts are unseated from the handle and the handle connectors are slightly separated from each other.
- The lower handle connector has three marked lines on the top and the upper handle connector has one marked line. See Figure 5.
- To raise the upper handle, move the upper handle forward to match the single marked line with the front marked line on the lower handle connector.
- To lower the upper handle, move the upper handle rearward to match the single marked line with the rear marked line on the lower handle connector.

- Secure the handle connectors in position by tightening each wing nut (carriage bolts must be seated properly into the handle and grooves must line up between connectors). Also make certain the bottom tip of the upper handle connector in front of the bottom tip of lower handle connector. See Figure 5.

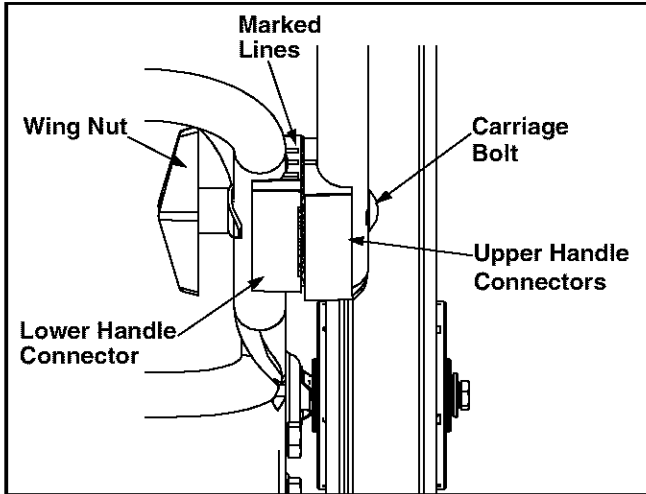

Figure 5

Spindle Height Adjustment

To adjust height of the spindle assembly proceed as follows:

- The trimmer line is connected to the spindle disc, which can be raised or lowered. See Figure 6.
- The spindle disc in the normal position rest on the spindle cap approximately 2" off the ground.
- Loosen, but do not remove each wing nut on spindle shaft.



WARNING: The wings nuts are designed not to be removed from the spindle shaft by hand or using a tool.

- Slide spindle disc along shaft to the desired position and tighten wing nuts to secure in position.
- The spindle disc can be adjusted from 2" to 4".

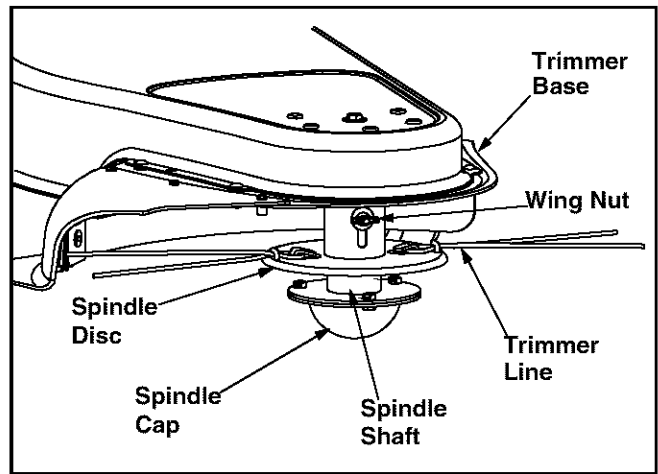

Figure 6

SECTION 7: MAINTAINING YOUR STRING TRIMMER MOWER

Customer Responsibilities

MAINTENANCE SCHEDULE		Before each use	Every 25 hours	Every 50 hours	Every 100 hours	Once a season	Before storage	SERVICE DATES						
PRODUCT	Lubricate Wheels					✓								
	Clean Trimmer Deflector	✓					✓							
	Check Trimmer Line	✓												
	Check Belt Tension		✓											
ENGINE	Check Oil	✓												
	Change Oil		✓				✓							
	Replace Air Filter		✓			✓								
	Clean Engine Intake Screen	✓					✓							
	Check Spark Plug			✓		✓								
	Check Spark Arrester (if any)			✓		✓								



WARNING: Always stop engine and disconnect spark plug wire before cleaning, lubricating or doing any kind of maintenance on your string trimmer mower.

Lubrication

Control Lever: Lubricate the pivot points on the control lever at least once a season with light oil. See Figure 7.

Wheels: Lubricate the wheels at least once a season with light oil. See Figure 7.

Engine: Follow the separate engine manual packed with you unit for lubrication instructions.

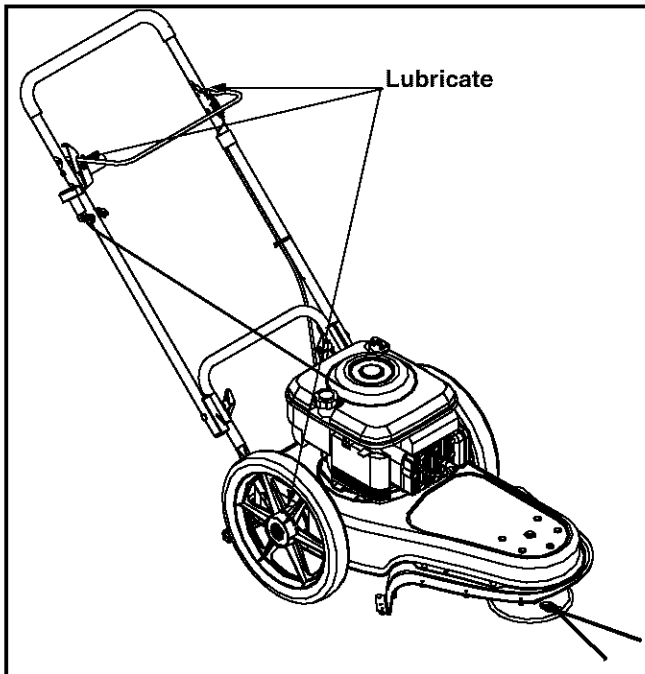

Figure 7

Maintenance

NOTE: When tipping the unit, empty the fuel tank and keep the spark plug side of engine up. Never tip the string trimmer mower more than 90 degrees and do not leave the unit tipped for any length of time. Oil can drain into the upper part of the engine causing a starting problem.

Engine

Refer to the separate engine manual for all engine maintenance instructions.

- Check **engine oil level** before each use as instructed in the separate engine manual packed with your unit. Read and follow instructions carefully.
- Replace **air cleaner** every 25 hours under normal conditions or once a season. Clean every few hours under extremely dusty conditions. To service the air

cleaner, refer to the separate engine manual packed with your unit.

- The **spark plug** should be cleaned and the gap reset once a season. Check engine manual for correct plug type and gap specifications.

Threading Trimmer Line



WARNING: Always stop engine, disconnect spark plug wire, and ground against the engine before threading trimmer line on your string trimmer mower. Wait for the trimmer line to stop rotating.

When the trimmer line becomes too short or worn, change to a new trimmer line as follows:

- Remove the worn trimmer line and replace with new trimmer line packed with your string trimmer mower. Always use OEM-743-0112 when purchasing additional trimmer line.
- Fold new trimmer line in half and thread the ends of line through the loop from the inside out without going all the way through the loop. See Figure 8.
- Slide the loop end of the trimmer line under the metal tab and secure in place by crossing and pulling tight on the ends of the line. See Figure 8.

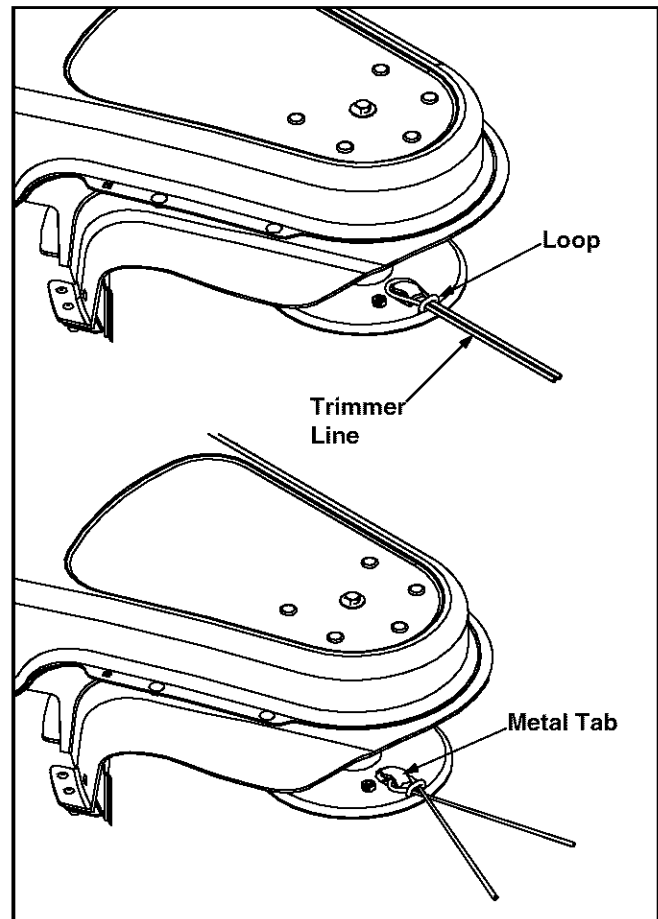

Figure 8

Drive Belt Removal And Replacement

- Disconnect the spark plug wire and ground it against the engine.
- Drain the fuel tank or place a piece of plastic beneath the cap to prevent gasoline leakage.
- If unit is tipped for easier access to belt, tip the string trimmer mower back on its side to keep engine spark plug side up.
- Remove the trimmer line from both sides of the spindle assembly.
- Remove carriage screws, washers, and hex nuts that secure the trimmer deflector to the base. See Figure 9.
- Slide trimmer deflector off so spindle assembly goes through hole in deflector.
- Loosen the wing nuts and slide the spindle disc to the highest position and tighten to secure in position. Refer to Figure 6.

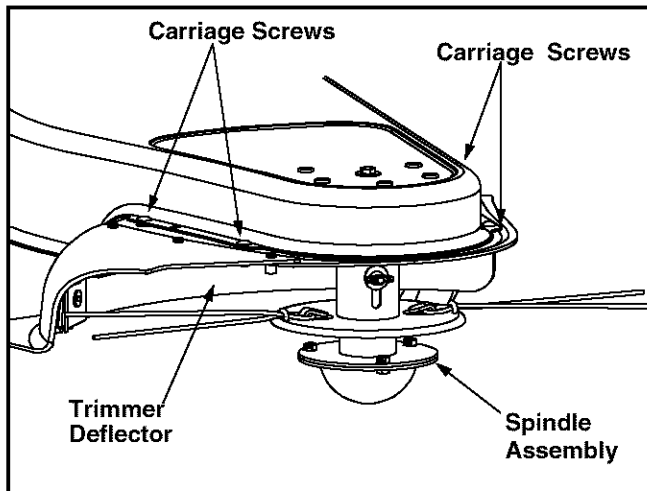

Figure 9

- Remove lock nut that secures idler bracket keeper and idler pulley to idler bracket assembly and remove keeper. See Figure 10.
- Slip the belt around engine pulley first and then spindle assembly pulley.
- Remove the belt from the unit by slipping it around the spindle disc and then around the engine flywheel.
- Reinstall new belt around the engine flywheel first and then around the spindle and spindle pulley.

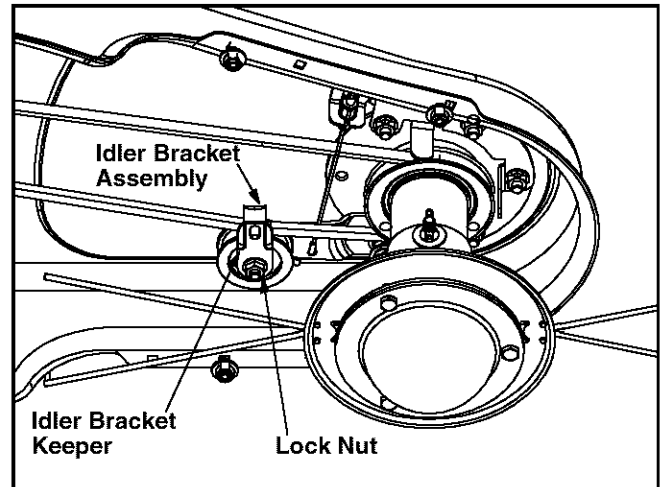

Figure 10

- Reconnect idler bracket keeper to the idler bracket assembly.
- Reattach trimmer deflector to trimmer base.
- Adjust the spindle height to the desired position.
- Reattach spark plug wire to spark plug.

Storing Your String Trimmer Mower

- Clean the equipment thoroughly.
- Wipe equipment with a oiled rag to prevent rust.
- Refer to engine manual for correct engine storage instructions.
- Store unit in a clean, dry area. Do not store next to corrosive materials such as fertilizer.
- For more compact storage, store unit in the shipping position with the upper handle folded toward engine. See ASSEMBLY section for details.

SECTION 8: TROUBLESHOOTING

Problem	Cause	Remedy
Engine fails to start	<ol style="list-style-type: none"> 1. Spark plug wire disconnected. 2. Fuel tank empty or stale fuel. 3. Throttle control lever not in correct starting position. (If Equipped) 4. Blocked fuel line. 5. Faulty spark plug. 6. Engine flooded 	<ol style="list-style-type: none"> 1. Connect wire to spark plug. 2. Fill tank with clean, fresh gasoline. 3. Move throttle lever to FAST or START position. 4. Clean fuel line. 5. Clean, adjust gap, or replace. 6. Wait a few minutes to restart, but do not prime.
Engine runs erratic	<ol style="list-style-type: none"> 1. Spark plug wire loose. 2. Blocked fuel line or stale fuel. 3. Vent in gas cap plugged. 4. Water or dirt in fuel system. 5. Dirty air cleaner. 6. Carburetor out of adjustment. 	<ol style="list-style-type: none"> 1. Connect and tighten spark plug wire. 2. Clean fuel line; fill tank with clean, fresh gasoline 3. Clear vent. 4. Drain fuel tank. Refill with fresh fuel. 5. Replace air cleaner. 6. See authorized service dealer.
Engine overheats	<ol style="list-style-type: none"> 1. Engine oil level low. 2. Dirty air cleaner. 3. Air flow restricted. 4. Carburetor not adjusted properly. 	<ol style="list-style-type: none"> 1. Fill crankcase with proper oil. 2. Replace air cleaner. 3. Remove blower housing and clean. 4. See authorized service dealer.
Occasional skip (hesitates) at high speed	<ol style="list-style-type: none"> 1. Spark plug gap too close. 	<ol style="list-style-type: none"> 1. Adjust gap to .030".
Idles poorly	<ol style="list-style-type: none"> 1. Spark plug fouled, faulty or gap too wide. 2. Carburetor improperly adjusted. 3. Dirty air cleaner. 	<ol style="list-style-type: none"> 1. Reset gap to .030" or replace spark plug. 2. See authorized service dealer. 3. Replace air cleaner.
Poor trimming performance	<ol style="list-style-type: none"> 1. Trimmer string too short. 2. Trimmer string lengths are substantially different. 3. Dirty air cleaner. 4. Engine not at FULL throttle. 5. Belt does not have enough tension. 	<ol style="list-style-type: none"> 1. Replace trimmer string. 2. Adjust trimmer string to equal lengths. 3. Replace air cleaner. 4. Set engine to FULL throttle. (If Equipped) 5. Check idler for proper belt tension.

NOTE: For repairs beyond the minor adjustments listed above, contact your nearest authorized service dealer.

Model 258

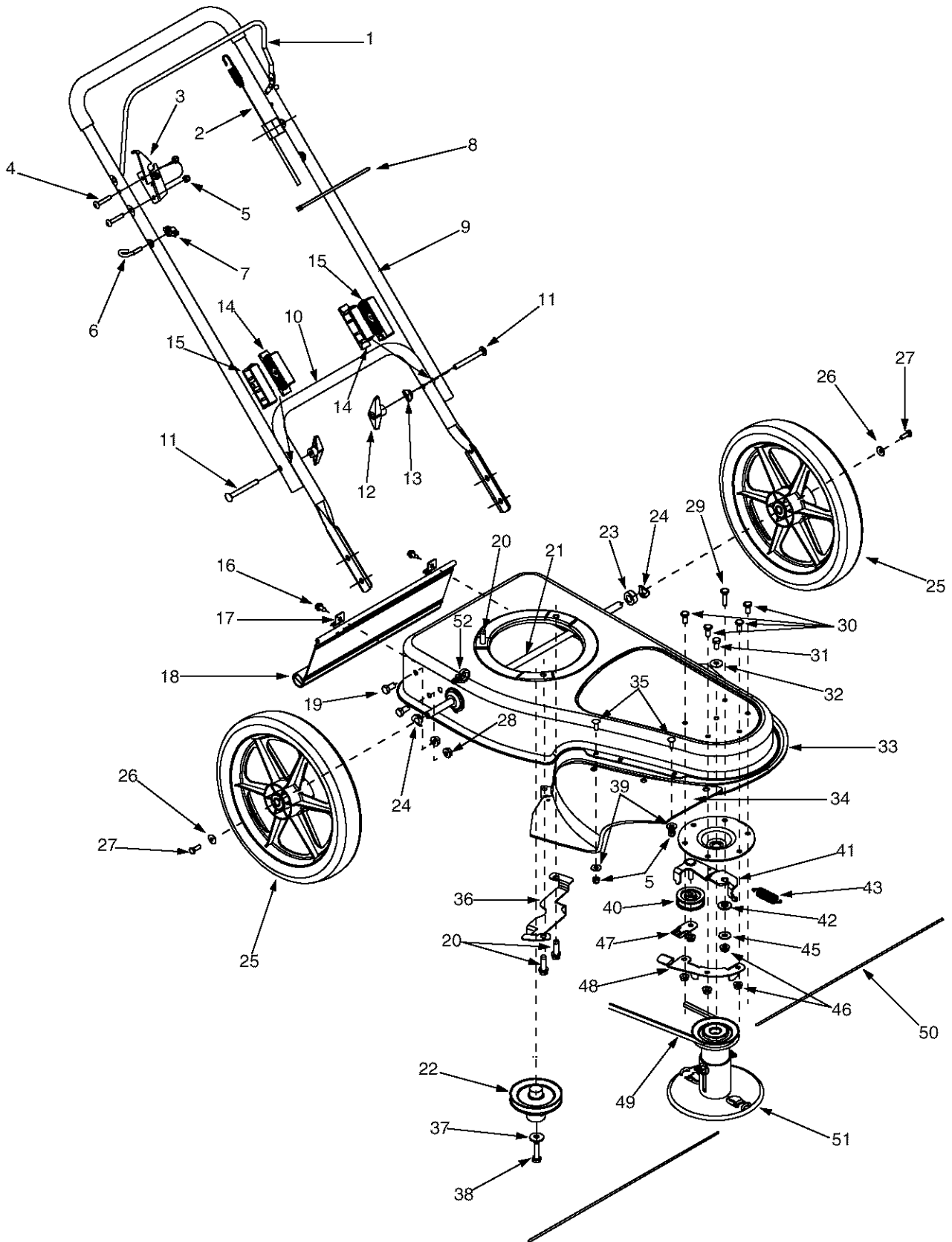

Model 258

Ref. No.	Part No.	Part Description	Ref. No.	Part No.	Part Description
1.	747-0824	Control Lever	27.	710-3015	Hex Cap Screw 1/4-20 x .75
2.	746-1116A	Engagement Cable	28.	712-3005	Flange Lock Nut 3/8-16
3.	681-0166	Control Lock Bracket	29.	710-1694	Screw 5/16-18 x 1.25
4.	710-0578	Machine Screw 1/4-20 x 1.50	30.	710-1307	Screw 5/16-18 x .75
5.	712-0324	Hex Lock Nut 1/4-20	31.	710-0237	Hex Cap Screw 5/16-24 x .625
6.	710-1205	Eye Bolt 1/4-20	32.	736-0425	Bell Washer .325 ID x .930 OD
7.	720-0279	Wing Nut	33.	681-0165	Trimmer Base Assembly
8.	726-0240	Cable Tie	34.	631-0096	Trimmer Deflector Assembly
9.	749-1255	Upper Handle	35.	710-0703	Hex Carriage Screw 1/4-20 x .75
10.	749-1254	Lower Handle	36.	781-1007	Belt Keeper Bracket Engine
11.	710-0450	Carriage Screw 5/16-18 x 3.0	37.	736-0452	Bell Washer .396 ID x 1.14 OD
12.	720-0284	Wing Nut	38.	710-0331	Hex Cap Screw 3/8-24 x 1.50
13.	736-0451	Shoulder Washer .320 ID x .93 OD	39.	736-0173	Flat Washer .28 ID x .74 OD
14.	731-1267	Lower Handle Connector	40.	756-1198	Idler Pulley
15.	731-1268	Upper Handle Connector	41.	681-0181A	Idler Bracket Assembly
16.	710-0896	Hex Washer Screw 1/4-14 x .625	42.	750-1275	Idler Spacer
17.	782-9065	Trail Shield Clip	43.	732-1166	Extension Spring .50 Dia x 1.88 Lg
18.	731-2329	Trail Shield	45.	736-0371	Flat Washer
19.	710-0216	Hex Cap Screw 3/8-16 x .750	46.	712-3004A	Flange Lock Nut 5/16-18
20.	710-0502A	Hex Washer Screw 3/8-16 x 1.25	47.	781-1028	Idler Keeper Bracket
21.	681-0159	Trimmer Axle	48.	781-1020	Belt Keeper Bracket Front
22.	756-1223	Flywheel Pulley	49.	754-0625A	V-Belt
23.	750-1240	Spacer .51 ID x 1.0 OD	50.	OEM-743-0112	Trimmer Line .155 Dia
24.	736-0182	Spacer Washer .501 ID x 1.0 OD	51.	618-0558	Spindle Assembly
25.	734-2050	Wheel Assembly	52.	726-3055	Cable Retainer Clip
26.	736-0270	Bell Washer .265 ID x .75 OD			

MANUFACTURER'S LIMITED WARRANTY FOR:



The limited warranty set forth below is given by Troy-Bilt LLC with respect to new merchandise purchased and used in the United States, its possessions and territories.

Troy-Bilt LLC warrants this product against defects for a period of two (2) years commencing on the date of original purchase and will, at its option, repair or replace, free of charge, any part found to be defective in materials or workmanship. This limited warranty shall only apply if this product has been operated and maintained in accordance with the Operator's Manual furnished with the product, and has not been subject to misuse, abuse, commercial use, neglect, accident, improper maintenance, alteration, vandalism, theft, fire, water, or damage because of other peril or natural disaster. Damage resulting from the installation or use of any accessory or attachment not approved by Troy-Bilt LLC for use with the product(s) covered by this manual will void your warranty as to any resulting damage.

Normal wear parts or components thereof are subject to separate terms as follows: All normal wear parts or component failures will be covered on the product for a period of 90 days regardless of cause. After 90 days, but within the two year period, normal wear part failures will be covered ONLY IF caused by defects in materials or workmanship of OTHER component parts. Normal wear parts and components include, but are not limited to: batteries, belts, blades, blade adapters, grass bags, rider deck wheels, seats, snow thrower skid shoes, shave plates, auger spiral rubber, and tires.

HOW TO OBTAIN SERVICE: Warranty service is available, WITH PROOF OF PURCHASE, through your local authorized service dealer. To locate the dealer in your area, check your Yellow Pages, or contact Troy-Bilt LLC at P.O. Box 361131, Cleveland, Ohio 44136-0019, or call 1-866-840-6483 or 1-330-558-7220, or log on to our Web site at www.troybilt.com.

This limited warranty does not provide coverage in the following cases:

- a. The engine or component parts thereof. These items carry a separate manufacturer's warranty. Refer to applicable manufacturer's warranty for terms and conditions.
- b. Log splitter pumps, valves, and cylinders have a separate one year warranty.
- c. Routine maintenance items such as lubricants, filters, blade sharpening, tune-ups, brake adjustments, clutch adjustments, deck adjustments, and normal deterioration of the exterior finish due to use or exposure.

- d. Troy-Bilt LLC does not extend any warranty for products sold or exported outside of the United States, its possessions and territories, except those sold through Troy-Bilt LLC's authorized channels of export distribution.
- e. Parts that are not genuine Troy-Bilt parts are not covered by this warranty.
- f. Service completed by someone other than an authorized service dealer is not covered by this warranty.
- g. Transportation charges and service calls are not covered.

No implied warranty, including any implied warranty of merchantability of fitness for a particular purpose, applies after the applicable period of express written warranty above as to the parts as identified. No other express warranty, whether written or oral, except as mentioned above, given by any person or entity, including a dealer or retailer, with respect to any product, shall bind Troy-Bilt LLC. During the period of the warranty, the exclusive remedy is repair or replacement of the product as set forth above.

The provisions as set forth in this warranty provide the sole and exclusive remedy arising from the sale. Troy-Bilt LLC shall not be liable for incidental or consequential loss or damage including, without limitation, expenses incurred for substitute or replacement lawn care services or for rental expenses to temporarily replace a warranted product.

Some states do not allow the exclusion or limitation of incidental or consequential damages, or limitations on how long an implied warranty lasts, so the above exclusions or limitations may not apply to you.

In no event shall recovery of any kind be greater than the amount of the purchase price of the product sold. **Alteration of safety features of the product shall void this warranty.** You assume the risk and liability for loss, damage, or injury to you and your property and/or to others and their property arising out of the misuse or inability to use the product.

This limited warranty shall not extend to anyone other than the original purchaser or to the person for whom it was purchased as a gift.

HOW STATE LAW RELATES TO THIS WARRANTY: This limited warranty gives you specific legal rights, and you may also have other rights which vary from state to state.

Troy-Bilt LLC, P.O. BOX 361131 CLEVELAND, OHIO 44136-0019; Phone: 1-866-840-6483, 1-330-558-7220