

PERFORMANCE DATA NO LOAD AND NO DOOR OPENINGS AT MID-POINT CONTROL SETTING		
Type A With Run Capacitor	65°F (18°C) Ambient	90°F (32°C) Ambient
Operating Time	25 to 35%	45 to 55%
Freezer Temperature	2° to 8°F -17° to -13°C	0° to 5°F -18° to -15°C
Refrigerator Temperature	35° to 40°F 2° to 4°C	35° to 40°F 2° to 4°C
Low Side Pressure (cut-in)	8 to 16 psig 55 to 110 kPa	8 to 16 psig 55 to 110 kPa
Low Side Pressure (cut-out)	1 to 4 psig 7 to 28 kPa	1 to 4 psig 7 to 28 kPa
High Side Pressure (Last 1/3 of cycle)	110 to 120 psig 758 to 827 kPa	150 to 175 psig 1034 to 1207 kPa
Wattage (Last 1/3 of cycle)	140 to 185	140 to 185
Amps (Running)	1.1 to 1.6	1.1 to 1.6
Base Voltage	115 VAC	115 VAC

DEFROST SPECIFICATIONS				
Cabinet Size	Thermostat		Heater	
	Cut-in	Cut-out	Watts	Ohms
18' & 21'	25°F -4°C	47°F 8°C	375	35
15' & 17'	25°F -4°C	47°F 8°C	325	41

Defrost 30 Minutes Every 10 Hours of Compressor Run Time

CONDENSER FAN MOTOR		
Watts	RPM	Amps
2.3	1100 CW Opposite Shaft	.15 Running

ICE MAKER SPECIFICATIONS		
Electrical	115 Volts	60 Hertz
Thermostat	Opens at 48°F (9°C)	Closes at 15°F (-9°C)
Heater Wattage	165	

ICE MAKER CONNECTOR PLUG CONNECTIONS		
Wire Number	Wire Color	Connects to:
1	Green/Yellow	Ground
2	Yellow	Water Valve
3	Black	Line
4	Lt. Blue	Neutral

SERVICE DATA SHEET - 240379005

R134a STANDARD - AUTOMATIC DEFROST TOP FREEZER MODELS

IMPORTANT SAFETY NOTICE

The information provided herein is designed to assist qualified repair personnel only. Untrained persons should not attempt to make repairs due to the possibility of electrical shock. Disconnect power cord before servicing.

IMPORTANT

If any green grounding wires are moved during servicing, they must be returned to their original position and properly secured.

CAUTION: All electrical parts and wiring must be shielded from torch flame. Do not allow torch to contact insulation; it will char at 200°F and flash ignite (burn) at 500°F. Excessive heat will distort the plastic liner.

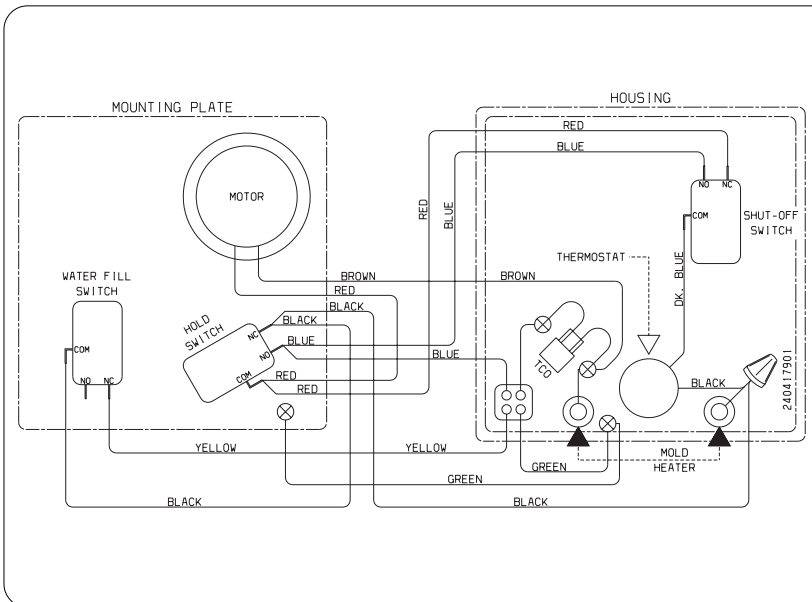

ICE MAKER INFORMATION

Test Cycling

Remove cover by inserting screwdriver in notch at bottom and prying cover from housing. Use screwdriver to rotate motor gear counterclockwise until *Holding Switch* circuit is completed. All components of ice maker should function to complete the cycle.

Water Fill Volume

The water fill adjustment screw will change the fill time. One full turn is equal to 20cc (.68 oz.). The correct fill is 102 to 130cc (3.4 to 4.3 oz.). When a water valve is replaced, the fill volume must be checked.

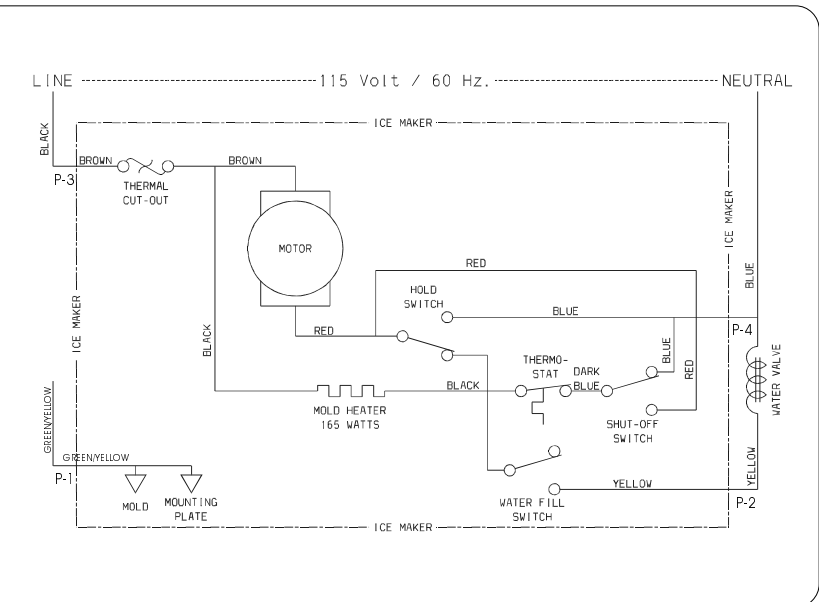

Pictorial Schematic

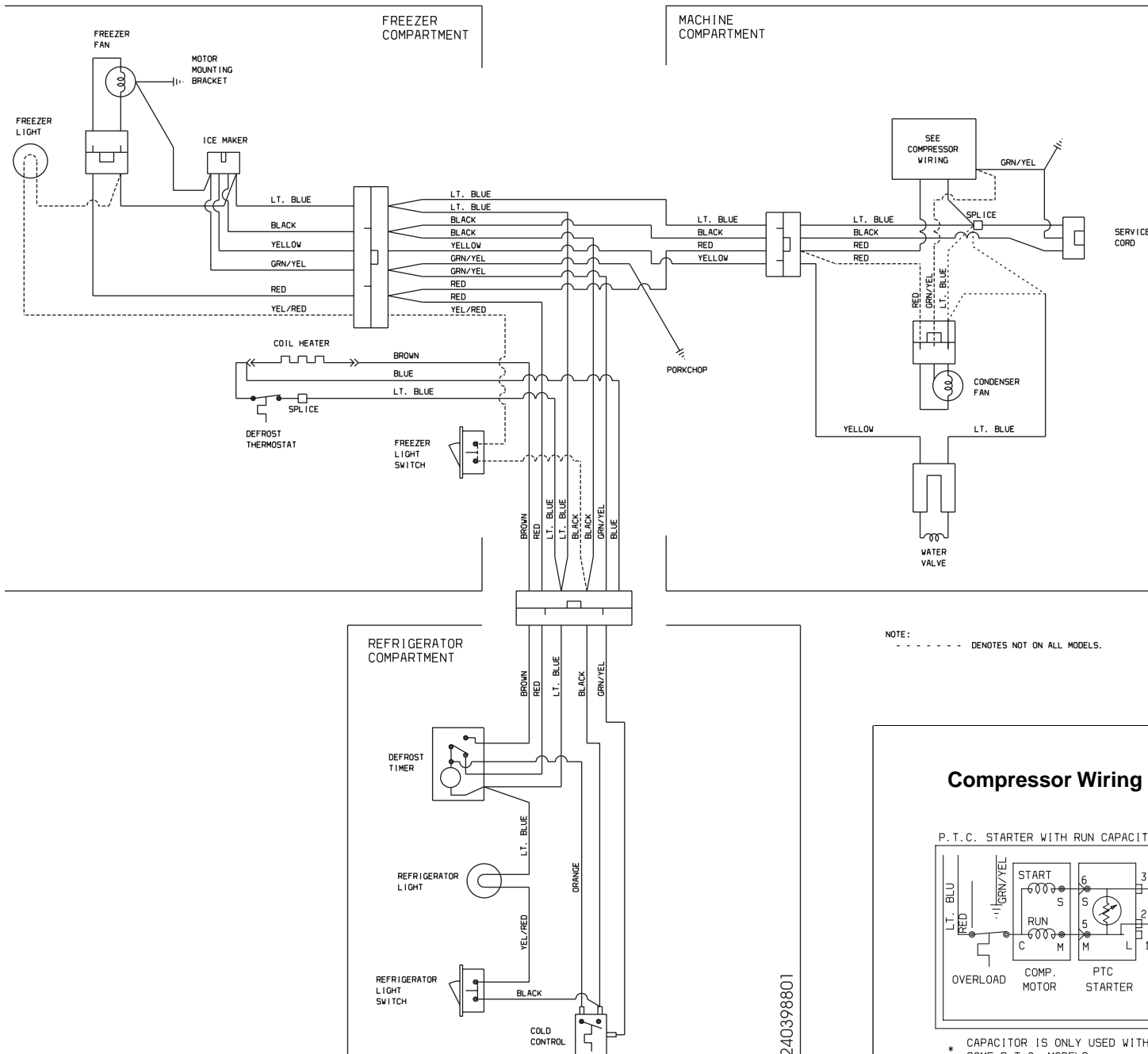

Ladder Schematic

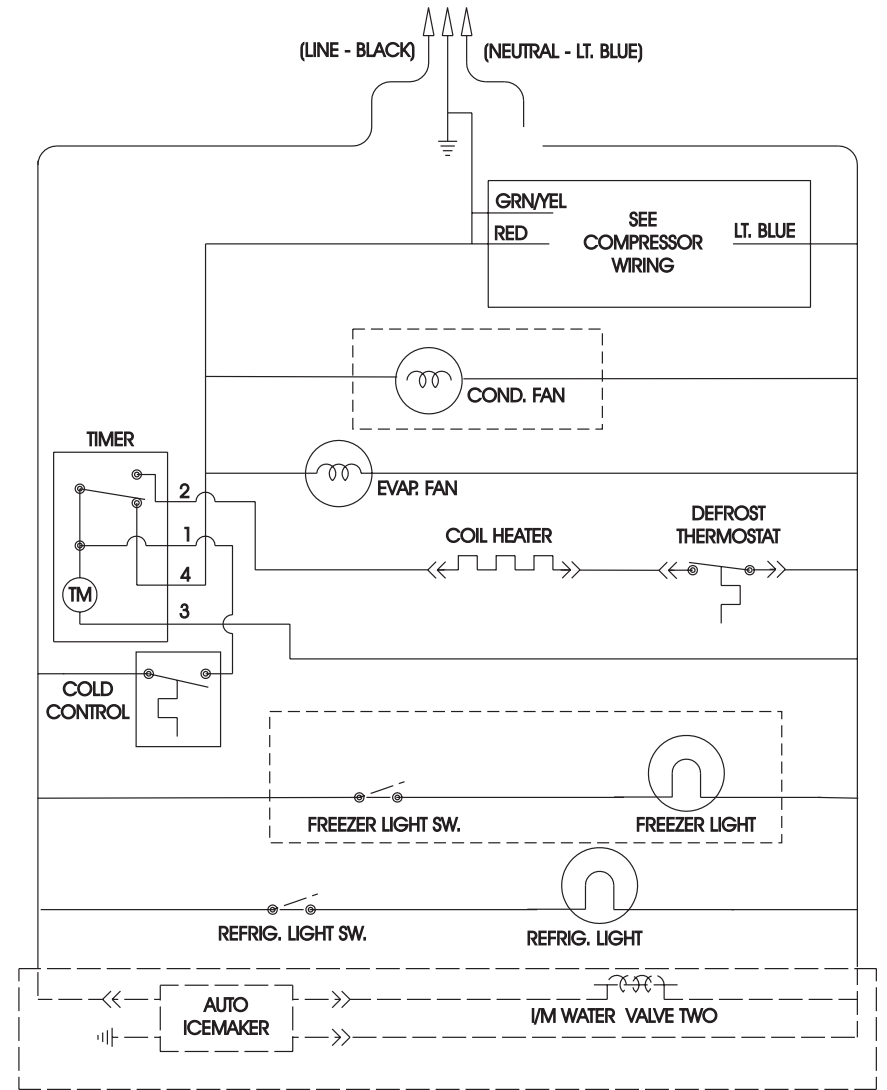

NOTE: - - - - DENOTES NOT ON ALL MODELS.

Compressor Wiring

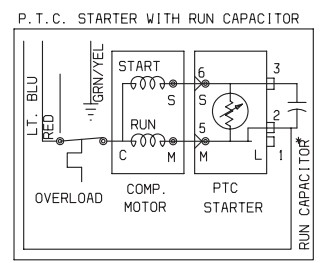

* CAPACITOR IS ONLY USED WITH SOME P. T. C. MODELS.

NOTE - - - - DENOTES NOT ALL MODELS