

## WHIRLPOOL BRAND COMMERCIAL DRYERS

### PORCELAIN FINISH

Porcelain finish on top with integrated backsplash, resists chipping and scratching.

### LARGE CAPACITY METERCASE

- Larger coin box for reduced collections.
- Accepts coin slides, coin drops, card readers and can be set up for OPL non-coin use.

### LARGE 6.7 CU. FT. DRUM CAPACITY

The increased capacity allows for large loads of clothes to tumble and spread out, saving you and your customers drying time and expense.

### SIDE SWING REVERSIBLE OPENING DOOR

- Extra-large opening
- See through door window and screen

### MICROPROCESSOR CONTROLS

- Time remaining display
- Front controls for ease-of-use
- Debit card compatible
- Time of Day Pricing

### AIRFLOW SYSTEM

Whirlpool® commercial dryers blower system increases air velocity. This increases efficiency, heating element life, and improves installation. You can now vent up to 100 ft. with 3 elbows, and 1 angled hood for versatility.

### 4-WAY VENTING

4-Way venting from left or right side, back or bottom.

### LARGE LINT FILTER

Pull-out, 84 square inch steel mesh lint filter.

### 1/3 HP MOTOR

1/3 HP motor with overload protection.

## COMMERCIAL DRYER

Featuring Microprocessor Controls



Shown with optional pedestal, coin drop and box.

### CEW9100WQ – 27" Electric Dryer with Metercase

### CGW9100WQ – 27" Gas Dryer with Metercase

### YCEW9100WQ – Canadian 27" Electric Dryer with Metercase

#### Machine accepts the Following Payment Systems (not included):

- Coin Slide
  - Retrofit Coin Drop
  - Retrofit Card Reader
  - OPL Non-Coin Money Acceptor And Coin Box Covers
- Side-Swing Reversible Door
  - Porcelain Finish on Top with Backsplash Resists Chipping and Scratching
  - Front-Service Accessibility
  - Electric Heating Element at 5600 Watts 240-Volt
  - Gas Model Features a 24K BTU Burner
  - Motor: 1/3-HP with Built-In Overload Protector; Centrifugal Switch Turns Off Heating Element in the Event of a Broken Belt
  - 3 Year Limited Parts Only Warranty
  - Money Acceptors Sold Separately
- Large 6.7 Cu. Ft. Drum Capacity
  - Four Roller Suspension with Permanently Lubricated Bearings
  - Push Button Controls
  - Large Lint Screen (84 Sq. In.)
  - Blower Guard Reduces Service Calls
  - Front Control Panel 24° Angle

\*Call 1-800-NO-BELTS for warranty details

# COMMERCIAL DRYER SPECIFICATIONS

## Whirlpool® Extra-Large Capacity Dryer MICROPROCESSOR CONTROLS

DRYER SPECIFICATIONS	
<b>MODEL</b>	CEW9100WQ/CGW9100WQ/YCEW9100WQ
<b>MOTOR</b>	
Single-phase, thermoprotected against overload, auto-reset	
HP (kw)	1/3 (.25)
<b>CAPACITY</b>	
Cu. ft. (liters)	6.7 (189.7)
<b>DOOR OPENING DIAMETER</b>	
In. (mm)	18.25 (463.5)
<b>AIRFLOW</b>	
Gas models — cfm (cmm)	230 (6.5)
Electric models — cfm (cmm)	215 (6.1)
Tumble Speed — RPM	50±1
<b>ELECTRICAL REQUIREMENTS</b>	
CEW model — voltage	240V/60Hz
CGW model — voltage	120V/60Hz
<b>BREAKER/FUSE REQUIREMENTS</b>	
CEW model — amps	30
CGW model — amps	15
<b>EXHAUST DUCT DIAMETER</b>	
In. (mm)	4 (101.6)
<b>ELECTRONIC BURNER IGNITION</b>	
CGW model	•
<b>HEATING ELEMENT RATING</b>	
CGW model — BTU/hr. (kcal/hr.)	24,000 (6,048)
CEW model — Electric Heating Element - watts	5,600
YCEW Canadian model — Electric Heating Element - watts	5,250
<b>GAS INLET</b>	
CGW model — in.	3/8 N.P.T.
<b>ADJUSTABLE LEVELING LEGS</b>	
<b>APPROXIMATE WEIGHT</b>	
Crated — lbs. (kg)	163 (74)
Uncrated — lbs. (kg)	150 (68)
<b>DIMENSIONS</b>	
Width — in. (mm)	27 (686)
Depth — in. (mm)	29 (737)
Height — in. (mm)	44.80 (1138)*

\* Height at metercase top does not include pedestal.  
See specific instructions for proper installation. Because of continuous product improvement, Whirlpool reserves the right to change specifications without notice.  
Power cords on electric models sold separately.  
LP Conversion Kit #W10135245.  
Pedestal Single Box Kit #WHPO400VW  
Pedestal Pack of 10 Kit #WHPO401VW

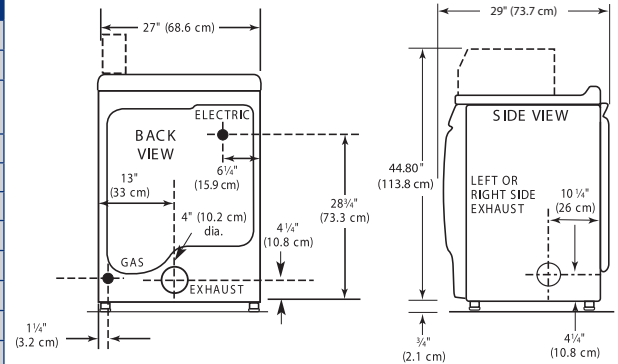

Dimensions are for planning purposes only.  
See Whirlpool® INSTALLATION INSTRUCTIONS for full details.

### MAXIMUM EXHAUST DUCT LENGTH PER NUMBER OF TURNS

Number Of 90° Turns	Rigid Metal Vent	
	Box Hood and Louvered Style	Angled Hood Style
0	135 ft. (41.2 m)	129 ft. (39.3 m)
1	125 ft. (38.1 m)	119 ft. (36.3 m)
2	115 ft. (35.1 m)	109 ft. (33.2 m)
3	106 ft. (32.3 m)	100 ft. (30.5 m)
4	98 ft. (29.9 m)	92 ft. (28.0 m)

Number Of 90° Turns	Flexible Metal Vent	
	Box Hood and Louvered Style	Angled Hood Style
0	76 ft. (23.2 m)	62 ft. (18.9 m)
1	71 ft. (21.6 m)	57 ft. (17.4 m)
2	67 ft. (20.4 m)	53 ft. (16.2 m)
3	65 ft. (19.8 m)	51 ft. (15.6 m)
4	63 ft. (19.2 m)	49 ft. (14.9 m)



NEW YORK CITY  
M.E.A.



### 3 YEARS LIMITED PARTS ONLY WARRANTY

For a period from the date of original purchase through the time listed above, the designated parts that fail in normal commercial use will be repaired or replaced free of charge for the part itself, with the owner paying all other costs, including labor, transportation and customs duty. Chemical damage is excluded from all warranty coverage. See complete warranty for details.

To Locate a Distributor Near You, Please Visit [www.whirlpoolcommerciallaundry.com/distributor](http://www.whirlpoolcommerciallaundry.com/distributor), or call 1-800-NO-BELTS

®Registered trademark/™Trademark of Whirlpool, U.S.A. ©2010 Whirlpool Corporation. All rights reserved.  
Whirlpool Corporation • Benton Harbor, Michigan 49022 U.S.A.