

# GRLP4 CONVERSION KIT APPLICATION INSTRUCTIONS

## Instructions for converting range to operate on Liquefied Petroleum Gas



**INSTALLATION AND SERVICE MUST BE PERFORMED BY  
A QUALIFIED INSTALLER.  
IMPORTANT: SAVE FOR LOCAL ELECTRICAL INSPECTOR'S USE.  
READ AND SAVE THESE INSTRUCTIONS FOR FUTURE REFERENCE.**



### WARNING

This conversion kit must be installed by a qualified service technician in accordance with the manufacturer's instructions and all applicable codes and requirements of the authority having jurisdiction. Failure to follow instructions may result in fire, explosion or production of carbon monoxide causing property damage, personal injury or loss of life. The qualified service agency is responsible for the proper installation of this kit. The installation is not proper and complete until the operation of the converted appliance is checked as specified in the manufacturer's instructions supplied with this kit.

### CAUTION

Before proceeding with the conversion, shut off the gas supply and disconnect the electrical power to the range. Be sure both power supplies are off before installing the conversion kit. Failure to do so could cause serious bodily injury.

**IMPORTANT: Do not attempt to use this conversion kit on products for which it is not specifically designated. Consult the product installation manual or parts list to determine the correct conversion kit number prior to use.**

### GRLP4 CONVERSION KIT - CONTENTS

QTY	Part Number	Item Description	Notes
1	316255600	Label, Insert Kit Screw Down Burner	
1	316527507	Orifice 16,000 Btu/h size 1.18	For Screw Mounted Burner (Style 1)
1	316527512	Orifice 14,000 Btu/h size 1.09	For Screw Mounted Burner (Style 1)
1	316527503	Orifice 12,000 Btu/h size 1.02	For Screw Mounted Burner (Style 1)
5	316527501	Orifice 9,500 Btu/h size .93	For Screw Mounted Burner (Style 1)
1	316527505	Orifice 5,000 Btu/h size .66	For Screw Mounted Burner (Style 1)
2	316527515	Orifice 15,000 Btu/h size .84	For Screw Mounted Burner (Style 2)
1	316527516	Orifice 750 Btu/h size .22	For Screw Mounted Burner (Style 2)

Qty	Part Number	Description	Surface Burner Combination	Qty	Part Number	Description	Surface Burner Combination
1	316005233	Rating Plate - English	4-9.5k	1	316005270	Rating Plate - French	1-9.5k, 1-14k, 1-12k, 1-5k
1	316005234	Rating Plate - French	4-9.5k	1	316005294	Rating Plate - French	1-16k, 1-12k, 2-9.5k, 1-5k
1	316005245	Rating Plate - English	3-9.5k, 1-12k	1	316005293	Rating Plate - English	1-16k, 1-12k, 2-9.5k, 1-5k
1	316005246	Rating Plate - French	3-9.5k, 1-12k	1	316005292	Rating Plate - French	1-12k, 4-9.5k
1	316005247	Rating Plate - English	3-9.5k, 1-14k	1	316005291	Rating Plate - English	1-12k, 4-9.5k
1	316005248	Rating Plate - French	3-9.5k, 1-14k	1	316005288	Rating Plate - French	1-15k, 1-14k, 2-9.5k, 1-5k
1	316005249	Rating Plate - English	2-9.5k, 1-12k, 1-5k	1	316005287	Rating Plate - English	1-15k, 1-14k, 2-9.5k, 1-5k
1	316005250	Rating Plate - French	2-9.5k, 1-12k, 1-5k	1	316005286	Rating Plate - French	1-14k, 3-9.5k, 1-5k
1	316005251	Rating Plate - English	2-9.5k, 1-5k, 1-14k	1	316005285	Rating Plate - English	1-14k, 3-9.5k, 1-5k
1	316005252	Rating Plate - French	2-9.5k, 1-5k, 1-14k	1	316005284	Rating Plate - French	5-9.5k
1	316005253	Rating Plate - English	1-9.5k, 1-12k, 1-5k, 1-16k	1	316005283	Rating Plate - English	5-9.5k
1	316005254	Rating Plate - French	1-9.5k, 1-12k, 1-5k, 1-16k	1	316005282	Rating Plate - French	1-16k, 1-12k, 2-9.5k, 1-5k
1	316005255	Rating Plate - English	2-9.5k, 1-12k, 1-5k, 1-16k	1	316005281	Rating Plate - English	1-16k, 1-12k, 2-9.5k, 1-5k
1	316005256	Rating Plate - French	2-9.5k, 1-12k, 1-5k, 1-16k	1	316005280	Rating Plate - French	1-16k, 1-14k, 1-9.5k, 1-5k
1	316005257	Rating Plate - English	4-9.5k, 1-5k	1	316005279	Rating Plate - English	1-16k, 1-14k, 1-9.5k, 1-5k
1	316005258	Rating Plate - French	4-9.5k, 1-5k	1	316005278	Rating Plate - French	1-16k, 1-14k, 2-9.5k, 1-5k
1	316005265	Rating Plate - English	1-9.5k, 1-12k, 1-5k, 1-14k	1	316005277	Rating Plate - English	1-16k, 1-14k, 2-9.5k, 1-5k
1	316005266	Rating Plate - French	1-9.5k, 1-12k, 1-5k, 1-14k	1	316005296	Rating Plate - French	1-14k, 1-12k, 2-9.5k, 1-5k
1	316005269	Rating Plate - English	1-9.5k, 1-14k, 1-12k, 1-5k	1	316005295	Rating Plate - English	1-14k, 1-12k, 2-9.5k, 1-5k

### Tools Required for L.P. Conversion:

- (A) 3/8", 1/2" and 5/8" Open End Wrench
- (B) #1 Square Tip Screwdriver
- (C) 1/8" Wide Flat Blade Screwdriver
- (D) 7mm & 3/16" Nutdriver

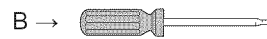

# Instructions for converting range to operate on Liquefied Petroleum Gas

## How to Convert the Range for use with LP/Propane Gas

**⚠ WARNING** Electrical Shock Hazard can occur and result in serious injury or death. Disconnect electrical power to the range before removing the warmer drawer for servicing.

### 1. Access gas regulator:

To access the gas regulator, remove the storage drawer or warmer drawer. If equipped with a storage drawer, open and remove the drawer completely. For models equipped with a front panel, remove the front panel and skip steps a & b below. For models equipped with warmer drawer, follow all the instructions below to remove the warmer drawer.

**NOTE:** Do not attempt to convert models that feature a lower oven.

- Locate glide lever on each side of drawer, pull up on the left glide lever and push down on the right glide lever (See Fig. 1).
- Pull the drawer away from the range.

### 2. Convert the pressure regulator:

**⚠ WARNING** Electrical Shock Hazard can occur and result in serious injury or death. Disconnect electrical power to the range before removing the warmer drawer for servicing.

- Remove the pressure regulator access cover (if equipped). DO NOT REMOVE the pressure regulator or allow it to turn.
- Remove the dust protector from the cap (See Fig. 2 - some models). Use a wrench to remove the cap from the pressure regulator (all models). Remove any gaskets.
- Follow the remaining conversion instructions depending on your pressure regulator style provided in Figs. 3 or 4. Once set for L.P./Propane replace gasket and cap then tighten.

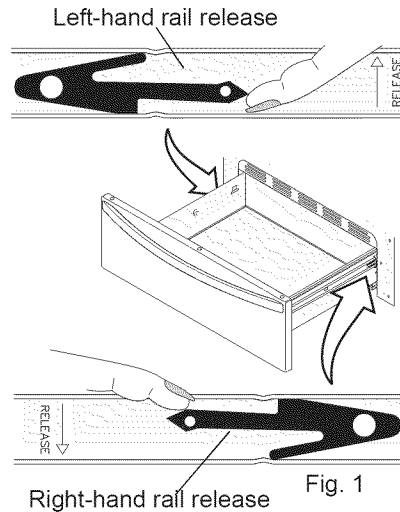

Fig. 1

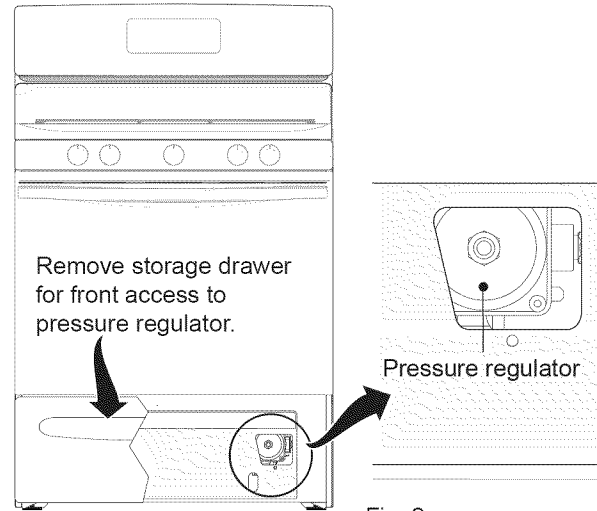
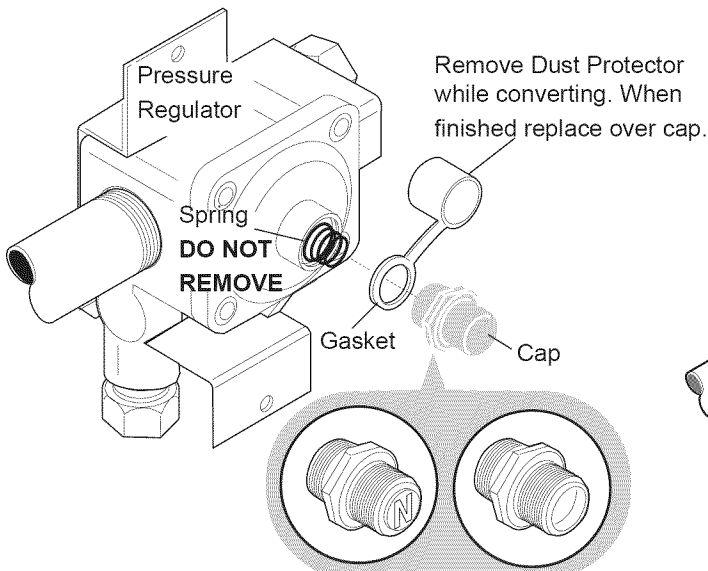

Fig. 2



Place hollow end of cap towards regulator for NATURAL GAS. When finished replace & tighten using gasket.

Place solid end of cap towards regulator for L.P./PROPANE. When finished replace & tighten using gasket.

Fig. 3

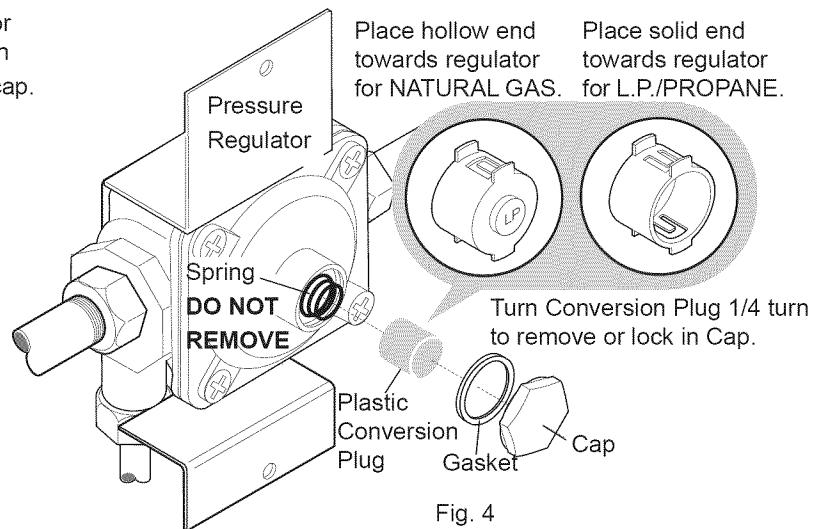

Fig. 4

# Instructions for converting range to operate on Liquefied Petroleum Gas

## 3. Convert Surface Burners for use with LP/Propane Gas

This conversion kit contains multiple gas orifices for converting different styles of sealed gas surface burners. Determine which style of gas surface burner is being converted and select the proper orifice from the designated orifice pack for that specific burner style and size.

Save the natural gas orifices removed from the appliance for possible future conversions to natural gas.

**BURNER STYLE #1** (Screw Mounted Burner) This burner is secured to the cooktop surface by two screws as seen in the photo. The screw heads may be different than those illustrated. When the burner is removed the orifice holder cutout in the cooktop can be seen to have an irregular elongated shape. The mounting screw sockets for the burner head are also visible. This style of burner will use the orifices contained in the separate smaller envelope found inside the main envelope of the LP kit # GRLP4. This envelope will be labeled "SCREW MOUNTED BURNER LP KIT". Follow the instructions on page 4 when converting this burner style.

**BURNER STYLE #2** (Screw Mounted Burner) This burner can be identified by the two piece cap as seen in the photo. It is secured to the cooktop surface by two screws. The screw heads may be different than those illustrated. When the burner is removed three orifice openings can be seen in the cooktop. This style of burner will use the orifices contained in the envelope found inside the main envelope of the LP kit # GRLP4. This envelope will be labeled "SCREW MOUNTED BURNER LP KIT". Follow the instructions on page 5 when converting this burner style.

**OVAL BURNERS** (Oval Burner) Use orifice size .93 from envelope.

**NOTE:** In the case the range includes multiple burner styles, use the appropriate orifice for each burner size.

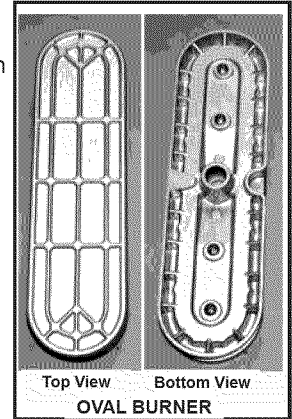
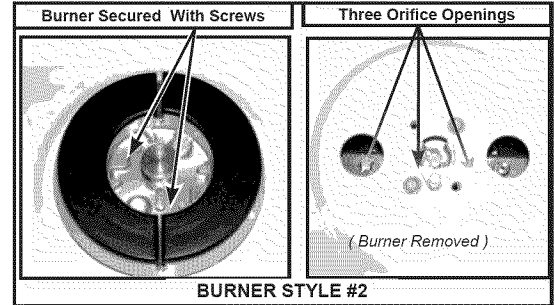
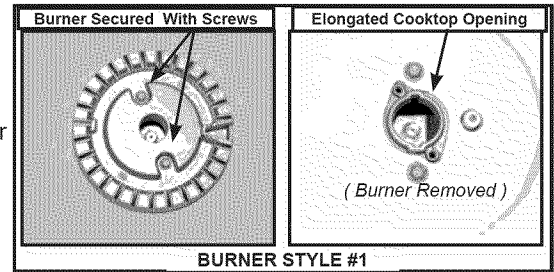

## BURNER STYLE #1 CONVERSION INSTRUCTIONS

**WARNING** Use caution when replacing each burner cap so the electrode is not damaged.

**CAUTION** THIS COOKTOP IS NOT REMOVABLE. Do not attempt to remove this cooktop.

Example of Burner Assembly

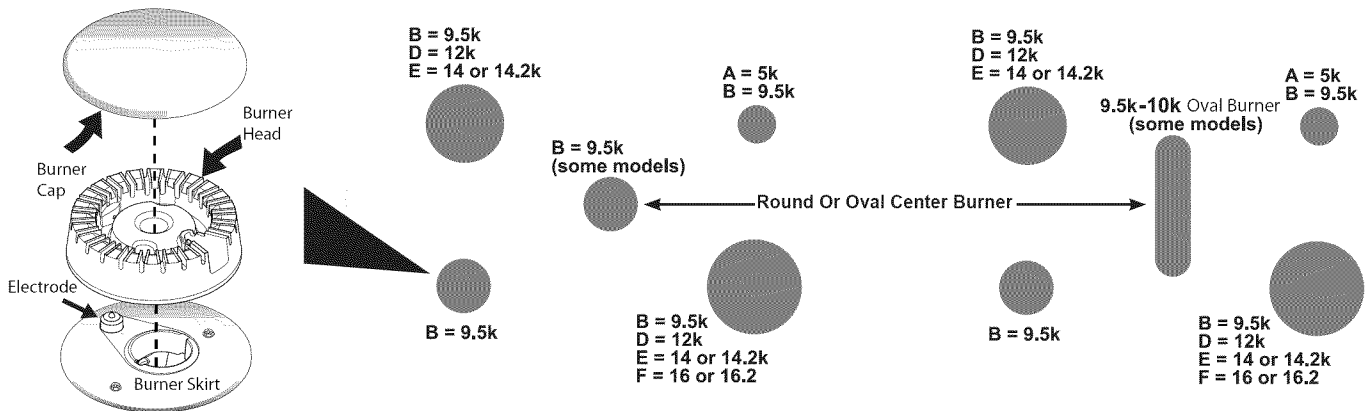

# Instructions for converting range to operate on Liquefied Petroleum Gas

## BURNER STYLE #1 CONVERSION INSTRUCTIONS

**⚠ WARNING** Use caution when replacing each burner cap so the electrode is not damaged.

**⚠ CAUTION** This cooktop is not removable. Do not attempt to remove this cooktop.

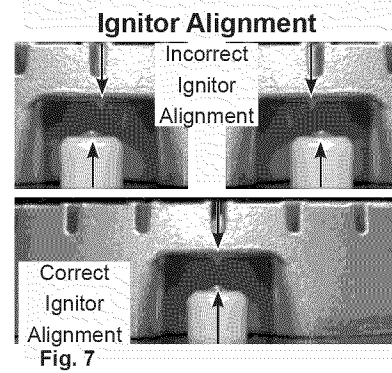
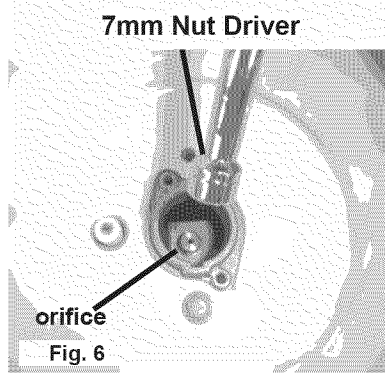
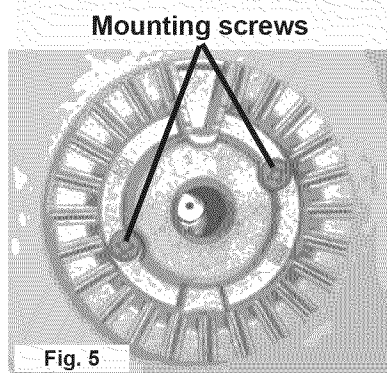

For all burner locations:

- Remove Burner Grates and Burner Caps.
- If the opening in the burner is too small to allow removal of the orifice, remove the burner as follows: Remove 2 screws using #1 square tip driver and remove Burner Heads (Fig. 5).

**Note:** Some models may have 3/16" hex head screws instead of square drive screws.

- Remove the factory installed natural gas orifices from the center of the orifice holders using a 7 mm nutdriver (See Fig. 6). Save the natural gas orifices removed from the appliance for possible future conversion back to natural gas.
- Following the chart below select the appropriate LP/Propane gas orifice from the envelope labeled SCREW MOUNTED BURNER LP KIT. EXAMPLE: Natural Gas orifice marked 1.07 is replaced by LP orifice marked .66. Tighten all orifices until snug. Use CAUTION not to overtighten.
- Replace burner heads at all locations and tighten each position with original screws using #1 square tip driver. Make sure that the center of the ignitor aligns with the center nib in the burner head (Fig. 7). Heads MUST have a Burner Cap installed to insure proper ignition and gas flame size.

GAS SURFACE BURNER ORIFICE DATA CHART (Burner Style #1)								
BTU Rating / Natural Gas	5,000	9,500	12,000	14,000	15,000	16,000	17,000	18,000
Natural Gas Orifice	1.07	1.46	1.67	1.87	1.95	1.98	2.1	2.2
L P Gas Orifice	0.66	0.93	1.02	1.09	1.09	1.18	1.18	1.18
LP Orifice Marking Color	Pink	White	Yellow	Brown	Brown	Silver	Silver	Silver
BTU Rating* / LP Gas	5,000	9,500	12,000	14,000	14,000	16,000	16,000	16,000

\*For operation at elevations above 2000 ft., appliance rating shall be reduced at the rate of 4 percent for each 1000 ft. above sea level.

# Instructions for converting range to operate on Liquefied Petroleum Gas

## BURNER STYLE #2 (TWIN BURNER) CONVERSION INSTRUCTIONS

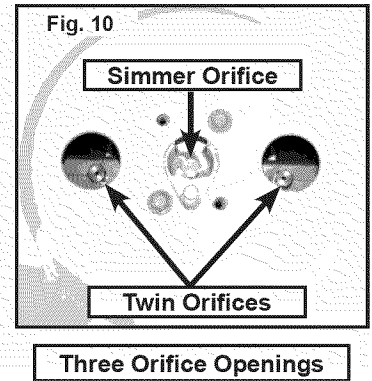
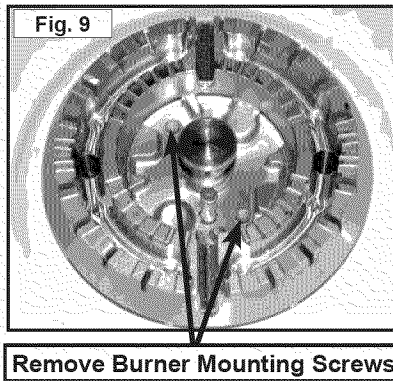
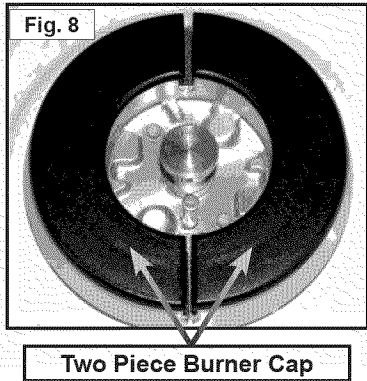

**CAUTION** THIS COOKTOP IS NOT REMOVABLE. Do not attempt to remove this cooktop.

For all burner locations:

- Remove burner grates & lift off the two piece burner cap. (Fig. 8)
- Remove the two burner mounting screws using the appropriate screwdriver or nutdriver and remove burner head (some burners may be secured with 3/16" hex head screws or square drive screws) (Figs 9).
- Remove the factory installed natural gas orifices from the orifice holders using a 7 mm nutdriver (See Fig 10). Save the natural gas orifices removed from the appliance for possible future conversion back to natural gas.
- Replace the orifice in each of the orifice holders with the appropriate LP/Propane gas orifice from the envelope labeled SCREW MOUNTED BURNER LP KIT.

**Note:** There are two identical orifices for the main portion of the burner and a separate smaller orifice for the center/ simmer portion of the burner. Tighten all orifices until snug. Use CAUTION not to overtighten.

- Replace burners at all locations and tighten each position with original screws. Burners MUST have a Burner Cap installed to insure proper ignition and gas flame size.

GAS SURFACE BURNER ORIFICE DATA CHART (Burner Style #2)			
	SIMMER	TWIN (Main)	TWIN (Main)
BTU Rating / Natural Gas	750	17,000	18,000
Natural Gas Orifice	0.43	1.46 (Qty 2)	1.67 (Qty 2)
L P Gas Orifice	0.22	0.84 (Qty 2)	0.84 (Qty 2)
LP Orifice Marking Color	Orange	Purple	Purple
BTU Rating* / LP Gas	750	15,000	15,000

\*For operation at elevations above 2000 ft., appliance rating shall be reduced at the rate of 4 percent for each 1000 ft. above sea level.

### 4. Convert Oven Burner Orifice for LP/Propane Gas (16,000 BTU\*)

- Locate the oven burner spud (See Fig. 11).
- Using a 1/2" wrench, turn down the adjustable spud, which injects gas into the oven burner, until snug against the LP/Propane metering pin (approximately 2-1/2 turns).
- Turn oven on to check flame appearance. Flame should be 3-4" with a minimum yellow flame. If flame is larger, tighten spud slightly and recheck. Repeat until flame is 3-4" and blue. Do not over tighten.

### 5. Convert Waist-High Broiler Burner Orifice Flame for LP/ Propane Gas (13,500 BTU\*) ( Some Models )

- Open the oven door.
- Locate the broiler burner spud and turn down until snug against the LP/ Propane metering pin (approximately 1 to 1-1/2 turns). (See Fig. 11).
- Turn oven on to check flame appearance. Flame should be 3-4" with a minimum yellow flame. If flame is larger, tighten spud slightly and recheck. Repeat until flame is 3-4" and blue. Do not over tighten.

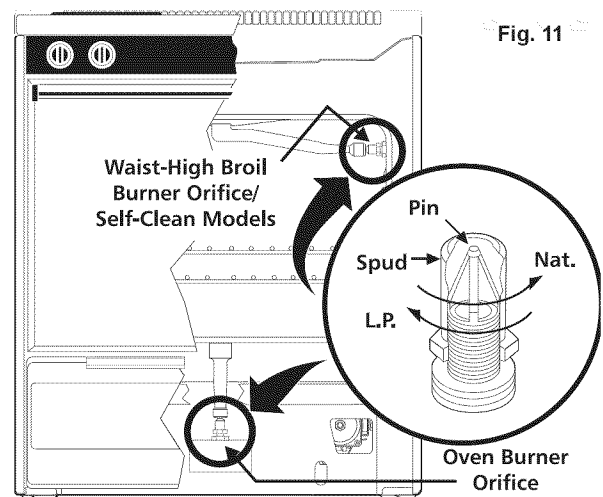

**Note:** For operation at elevations above 2000 ft., appliance rating shall be reduced at the rate of 4 percent for each 1000 ft. above sea level.

# Instructions for converting range to operate on Liquefied Petroleum Gas

## 6. Reconnect Gas and Electrical Supply to Range.

**CAUTION** Do not use a flame to check for gas leaks.

Leak testing of the appliance shall be conducted according to the Installation Instructions provided with the Range.

### Checking Manifold Gas Pressure

If it should be necessary to check the manifold gas pressure, remove the burner cap and connect a manometer (water gauge) or other pressure device to the top right front burner orifice. Using a rubber hose with inside diameter of approximately 1/4," hold tubing down tight over orifice. Turn burner valve on. For an accurate pressure check, have at least two (2) other surface burners burning. Be sure the gas supply (inlet) pressure is at least one inch above specified range manifold pressure. The gas supply pressure should never be over 14" water column. When properly adjusted the manifold water column pressure is 10" for LP/Propane gas or 4" for Natural gas.

### Pressure Testing Gas Supply Piping System

- Disconnect the range and its individual shut-off valve from the gas supply piping system during any pressure testing of that system at test pressures greater than 14" of water column pressure (approximately 1/2" psig).
- Isolate the range from the gas supply piping system by closing its individual manual shut-off valve during any pressure testing of the gas supply piping system at test pressures equal to or less than 14" of water column pressure (approximately 1/2" psig).

## 7. Test surface burners to verify if "LOW" setting should be adjusted:

- Push in and turn control to LITE until burner ignites.
- Push in and quickly turn knob to LOWEST POSITION.
- If burner goes out, reset control to OFF.
- Remove the surface burner control knob.
- Insert a thin-bladed screwdriver into the hollow valve stem and engage the slotted screw inside. Flame size can be increased or decreased with the turn of the screw. Turn counterclockwise to increase flame size. Turn clockwise to decrease flame size. (See Figs. 12).

Adjust flame until you can quickly turn knob from LITE to LOWEST POSITION without extinguishing the flame. Flame should be as small as possible without going out.

**NOTE: For Twin Burner Valve Adjustments follow the instructions on page 5.**

## 8. Adjust the "LOW" Setting of the Twin Burner Surface Valve (Figure 13) (some models).

On the Twin burner surface valve the low setting of each portion (inner portion and outer portion of the twin burner) should be adjusted individually.

- Push in and turn control to ignite the burner
- Quickly turn knob to LOWEST POSITION.
- If burner goes out, reset control to OFF.
- Remove the surface burner control knob.
- The inner portion of the twin burner flame size can be increased or decreased with the turn of the screw A. Use screw B to adjust the flame size of the outer portion of the twin burner. Turn counterclockwise the screw to increase flame size. Turn clockwise the screw to decrease flame size. Adjust flame until you can quickly turn knob from LITE to LOWEST POSITION without extinguishing the flame. Flame should be as small as possible without going out.

**Note: Air mixture adjustment is not required on surface burners.**

## 9. Air Shutter-Oven Burner

The air shutter for the oven burner may need adjustment, especially if the unit has been converted for use with LP/Propane gas. The approximate flame length of the oven burner is 1 inch (distinct inner, blue flame) (See Fig. 14).

To determine if the oven burner flame is proper:

- To access the air shutter you must remove the storage drawer or warmer drawer (see removal instructions on page 2).
- Remove the oven bottom by removing the screws at rear of oven bottom. Lift up the rear of oven bottom and slide toward back of range to disengage from front of oven front frame.
- Remove burner baffle by removing nut located on top of baffle and two screws from front edge of oven front frame. Lift baffle straight up and out of the oven.

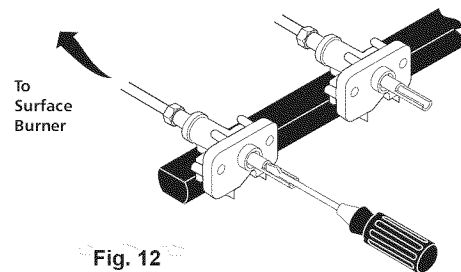

Fig. 12

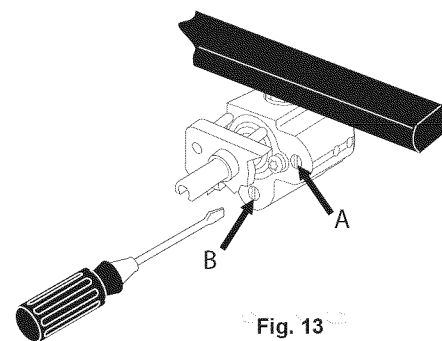

Fig. 13

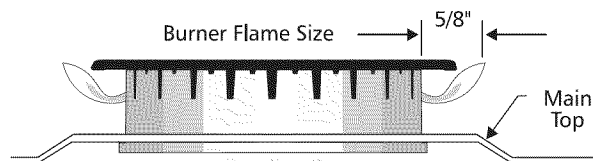

Fig. 14

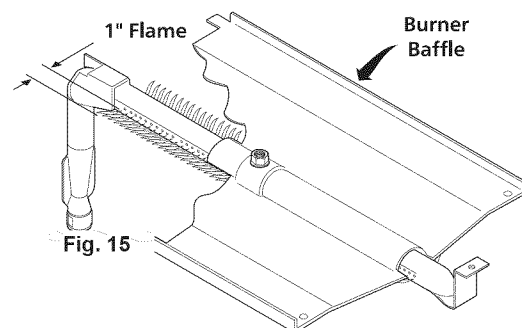
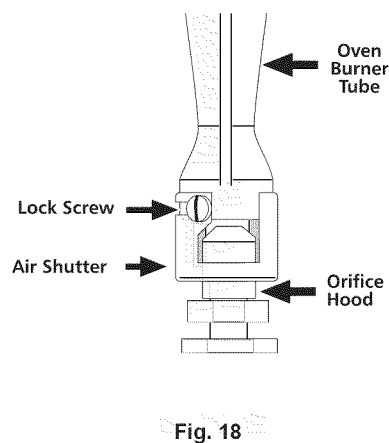
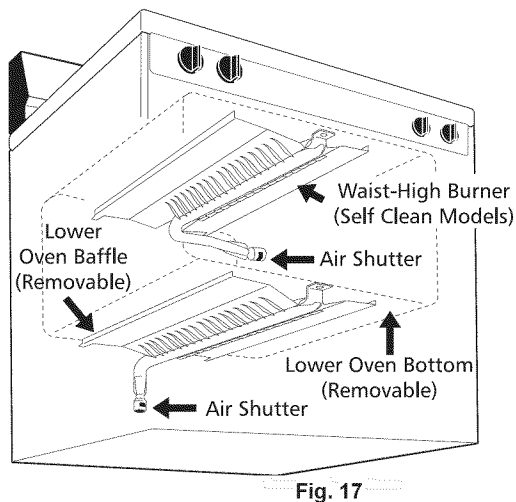
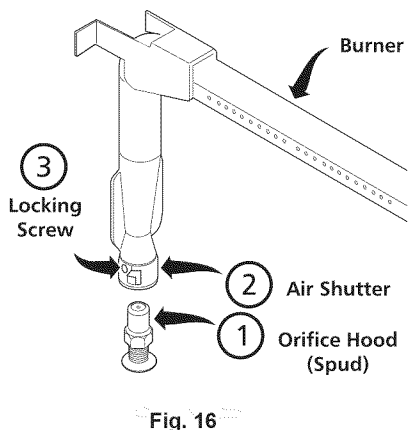

Fig. 15

# Instructions for converting range to operate on Liquefied Petroleum Gas



- d. Set the oven to bake at 350°F and observe the flame. If the flame is yellow in color, increase air shutter opening size. If the flame is a distinct blue color, but lifting away from the burner; reduce the air shutter opening size.
- e. Turn off oven and allow to cool before adjusting air shutter. To adjust, loosen lock-screw (3), reposition air shutter (2), and tighten lock-screw (3) (See Fig. 16). Retest the burner by repeating step “d” above. When the burner flame is a distinct blue color burning steady, the air shutter is adjusted correctly.
- f. Replace burner baffle and oven bottom.

## 10. Air Shutter-Broil Burner

- a. Observe the flame to determine if the broiler burner flame is properly adjusted. It should be steady with approximately 1” blue cones and no yellow or orange flame tips (See Fig. 17).
- b. If adjustment to the air shutter is necessary, locate the broiler burner air shutter (See Fig. 18), loosen shutter lock screw, and adjust to obtain optimum flame. This will normally be completely open for LP/Propane gas. If the flame is yellow in color, increase the air shutter opening size. If the flame is a distinct blue, but lifting away from the burner, reduce the air shutter opening size. Tighten the shutter set screw.

## 11. Replace Storage Drawer or Warmer Drawer (instructions for warmer drawer if equipped):

- a. Pull the bearing glides to the front of the chassis glide (See Fig. 19).
- b. Align the glide on each side of the drawer with the glide slots on the range.
- c. Push the drawer into the range until levers “click” (approximately 2”). Pull the drawer open again to seat bearing glides into position. If you do not hear the levers “click” or the bearing glides do not feel seated remove the drawer and repeat steps “a” through “c”. This will minimize possible damage to the bearing glides.

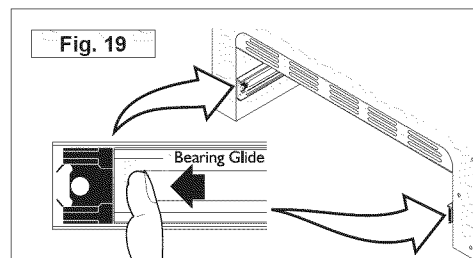

## 12. Installation of New LP/Propane Rating/Serial Plate and Conversion Label

- a. Using the list on page 1, determine the Surface Burner Combination that applies to the range after it has been converted and select the corresponding Rating Plate part number in the appropriate language (English/French).
- b. Use a pen or permanent marker to fill out the LP/Propane Rating/Serial plate. Include the date that the LP conversion was performed and the service company or individual performing the conversion. See the sample label below
- c. Place new plate as close as possible to the existing Rating/Serial plate on range (See the recommended locations shown in Fig. 20).
- d. Remove the lower storage or warmer drawer and install the Regulator L.P. Conversion Label in the location shown in figure 20.

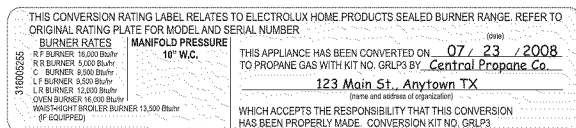
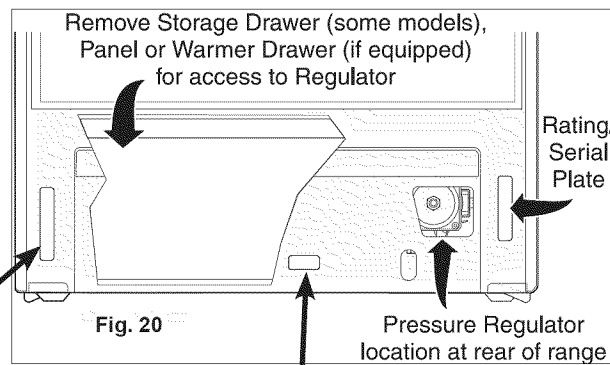

Sample - L.P. Rating/Serial Plate

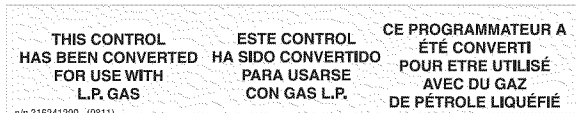

Sample - Regulator L.P. Conversion Label

# Instructions for converting range to operate on Liquefied Petroleum Gas

## CONVERSION TO NATURAL GAS

If it becomes necessary to convert the range back to natural gas:

- a. Disconnect gas and electrical supply from range.
- b. Convert pressure regulator (See step 1), turn cap over so the solid end of cap faces outward. Place the hollow end of the cap into the loop end of the dust protector.
- c. Remove the LP orifices using 7mm nutdriver and replace with the original factory installed natural gas orifices at their original locations (See figure 9 for locations).
- d. Convert Oven Burner Orifice for Natural Gas by loosening spud counter-clockwise (approximately 2-1/2 turns; See step 3).
- e. Convert Waist-High Broiler Burner Orifice (Self-Cleaning Models Only) for Natural Gas by loosening spud counter-clockwise (approximately 1 to 1-1/2 turns; See step 4.)
- f. Readjust "LOW" Setting for Surface Burner Valves following instructions. (See step 6.)
- g. Readjust Oven & Broil Burner Air Shutters. (See steps 7 & 8.)