

OPERATOR'S MANUAL

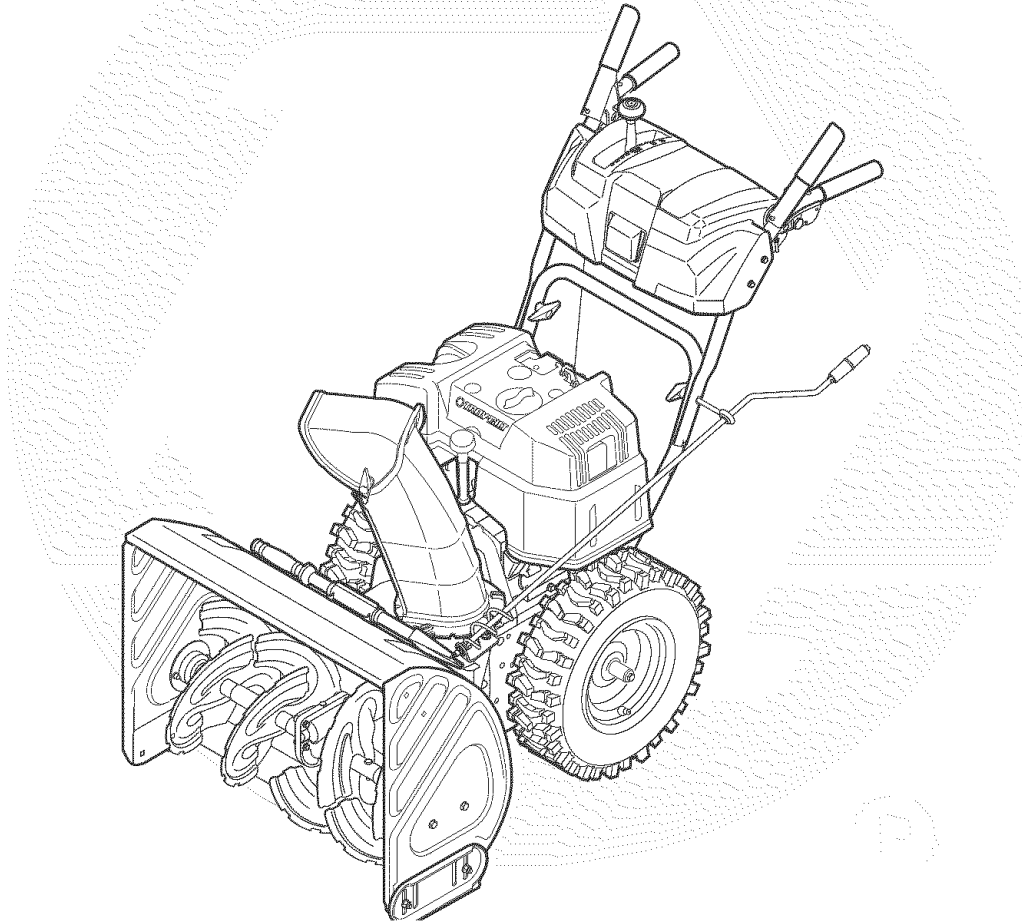

Two-Stage Snow Thrower — STORM 8526

IMPORTANT

READ SAFETY RULES AND INSTRUCTIONS CAREFULLY BEFORE OPERATION

Warning: This unit is equipped with an internal combustion engine and should not be used on or near any unimproved forest-covered, brush-covered or grass-covered land unless the engine's exhaust system is equipped with a spark arrester meeting applicable local or state laws (if any). If a spark arrester is used, it should be maintained in effective working order by the operator. In the State of California the above is required by law (Section 4442 of the California Public Resources Code). Other states may have similar laws. Federal laws apply on federal lands. A spark arrester for the muffler is available through your nearest engine authorized service dealer or contact the service department, P.O. Box 361131 Cleveland, Ohio 44136-0019.

This Operator's Manual is an important part of your new snow thrower. It will help you assemble, prepare and maintain the unit for best performance. Please read and understand what it says.

Table of Contents

Safety Labels	3	Maintaining Your Snow Thrower	14
Safe Operation Practices	4	Off-Season Storage	18
Setting Up Your Snow Thrower	6	Trouble Shooting	19
Operating Your Snow Thrower	8	Illustrated Parts List	20
Making Adjustments	12	Warranty	Back Cover

Finding and Recording Model Number

BEFORE YOU START ASSEMBLING YOUR NEW EQUIPMENT,

please locate the model plate on the equipment and copy the information to the sample model plate provided to the right. You can locate the model plate by standing at the operating position and looking down at the rear of the deck. This information will be necessary to use the manufacturer's web site and/or obtain assistance from the Customer Support Department or an authorized service dealer.

TROY-BILT®
www.troybilt.com

TROY-BILT LLC
P. O. BOX 361131
CLEVELAND, OH 44136
330-558-7220
1-800-520-5520

Customer Support

Please do **NOT** return the unit to the retailer from which it was purchased, without first contacting Customer Support.

If you have difficulty assembling this product or have any questions regarding the controls, operation or maintenance of this unit, you can seek help from the experts. Choose from the options below:

1. Visit **troybilt.com** for many useful suggestions. Click on Customer Support button and you will get the options reproduced in the screen shot below. Click on the appropriate button and help is immediately available.
2. Phone a **Customer Support Representative** at 1(800) 520-5520.
3. The **engine manufacturer** is responsible for all engine-related issues with regard to performance, power-rating, specifications, warranty and service. Please refer to the engine manufacturer's Owner's/Operator's Manual, packed separately with your unit, for more information.

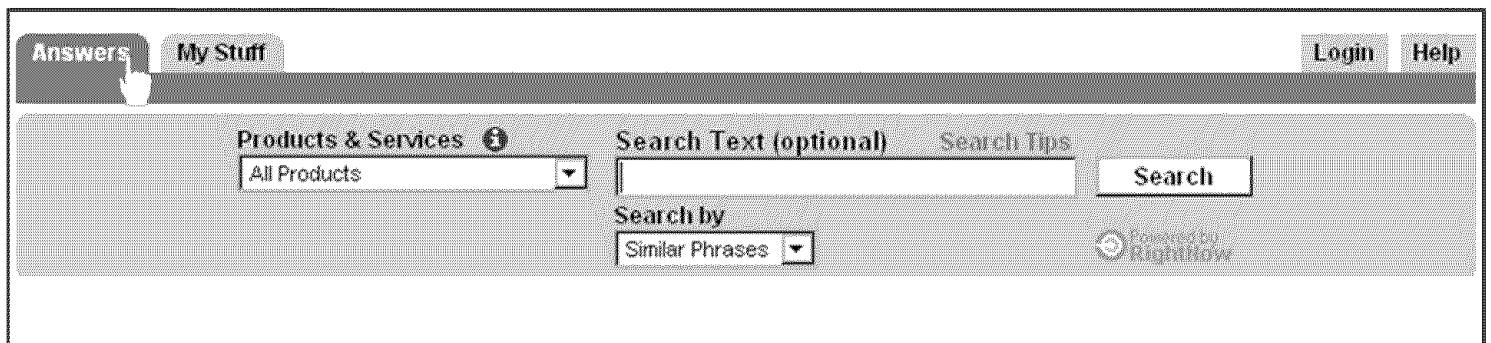

⚠ DANGER

1. KEEP AWAY FROM ROTATING IMPELLER AND AUGER. CONTACT WITH IMPELLER OR AUGER CAN AMPUTATE HANDS AND FEET.
2. USE CLEAN-OUT TOOL TO UNCLOG DISCHARGE CHUTE.
3. DISENGAGE CLUTCH LEVERS, STOP ENGINE, AND REMAIN BEHIND HANDLES UNTIL ALL MOVING PARTS HAVE STOPPED BEFORE UNCLOGGING OR SERVICING MACHINE.
4. TO AVOID THROWN OBJECTS INJURIES, NEVER DIRECT DISCHARGE AT BYSTANDERS. USE EXTRA CAUTION WHEN OPERATING ON GRAVEL SURFACES.
5. READ OPERATOR'S MANUAL.

CLEAN-OUT TOOL



⚠ DANGER

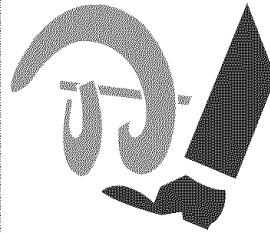

AVOID INJURY FROM ROTATING AUGER - KEEP HANDS, FEET AND CLOTHING AWAY.

⚠ DANGER

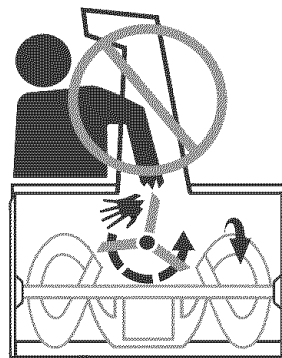

- NEVER PUT HAND IN CHUTE. CONTACT WITH ROTATING PARTS CAN AMPUTATE FINGERS AND HANDS.
- SHUT OFF ENGINE AND WAIT UNTIL ALL MOVING PARTS HAVE STOPPED BEFORE UNCLOGGING.
- USE CLEAN-OUT TOOL OR WOODEN STICK TO UNCLOG DISCHARGE CHUTE.

Chute Clean-out Tool

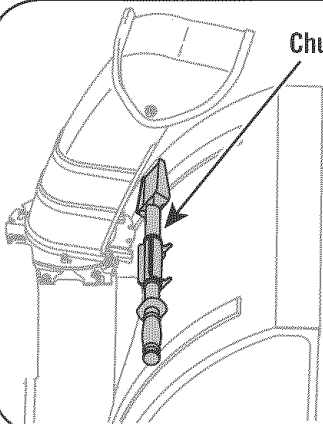

A chute clean-out tool is fastened to the top of the auger housing with a mounting clip. The tool is designed to clear a chute assembly of ice and snow.

This item is fastened with a cable tie at the factory. Cut the cable tie before operating the snow thrower.



WARNING: Never use your hands to clear a clogged chute assembly. Shut off engine and remain behind handles until all moving parts have stopped before using the clean-out tool to clear the chute assembly.

1

Safety Labels

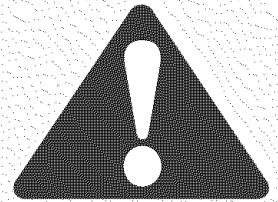

WARNING

This symbol points out important safety instructions which, if not followed, could endanger the personal safety and/or property of yourself and others. Read and follow all instructions in this manual before attempting to operate this machine. Failure to comply with these instructions may result in personal injury. When you see this symbol.

HEED ITS WARNING!

Your Responsibility

Restrict the use of this power machine to persons who read, understand and follow the warnings and instructions in this manual and on the machine.

2

Safe Operation Practices



WARNING

This symbol points out important safety instructions which, if not followed, could endanger the personal safety and/or property of yourself and others. Read and follow all instructions in this manual before attempting to operate this machine. Failure to comply with these instructions may result in personal injury. When you see this symbol.

HEED ITS WARNING!

Your Responsibility

Restrict the use of this power machine to persons who read, understand and follow the warnings and instructions in this manual and on the machine.

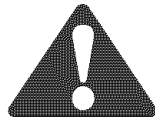

WARNING: Engine Exhaust, some of its constituents, and certain vehicle components contain or emit chemicals known to State of California to cause cancer and birth defects or other reproductive harm.

DANGER: This machine was built to be operated according to the rules for safe operation in this manual. As with any type of power equipment, carelessness or error on the part of the operator can result in serious injury. This machine is capable of amputating hands and feet and throwing objects. Failure to observe the following safety instructions could result in serious injury or death.

Training

1. Read, understand, and follow all instructions on the machine and in the manual(s) before attempting to assemble and operate. Keep this manual in a safe place for future and regular reference and for ordering replacement parts.
2. Be familiar with all controls and their proper operation. Know how to stop the machine and disengage them quickly.
3. Never allow children under 14 years old to operate this machine. Children 14 years old and over should read and understand the operation instructions and safety rules in this manual and should be trained and supervised by a parent.
4. Never allow adults to operate this machine without proper instruction.
5. Thrown objects can cause serious personal injury. Plan your snow-throwing pattern to avoid discharge of material toward roads, bystanders and the like.
6. Keep bystanders, helpers, pets and children at least 75 feet from the machine while it is in operation. Stop machine if anyone enters the area.
7. Exercise caution to avoid slipping or falling, especially when operating in reverse.

Preparation

1. Thoroughly inspect the area where the equipment is to be used. Remove all doormats, newspapers, sleds, boards, wires and other foreign objects, which could be tripped over or thrown by the auger/impeller.
2. Always wear safety glasses or eye shields during operation and while performing an adjustment or repair to protect your eyes. Thrown objects which ricochet can cause serious injury to the eyes.
3. Do not operate without wearing adequate winter outer garments. Do not wear jewelry, long scarves or other loose clothing, which could become entangled in moving parts. Wear footwear which will improve footing on slippery surfaces.
4. Use a grounded three-wire extension cord and receptacle for all units with electric start engines.
5. Adjust collector housing height to clear gravel or crushed rock surfaces.
6. Disengage all control levers before starting the engine.
7. Never attempt to make any adjustments while engine is running, except where specifically recommended in the operator's manual.
8. Let engine and machine adjust to outdoor temperature before starting to clear snow.
9. To avoid personal injury or property damage use extreme care in handling gasoline. Gasoline is extremely flammable and the vapors are explosive. Serious personal injury can occur when gasoline is spilled on yourself or your clothes, which can ignite. Wash your skin and change clothes immediately.
 - a. Use only an approved gasoline container.
 - b. Extinguish all cigarettes, cigars, pipes and other sources of ignition.
 - c. Never fuel machine indoors.
 - d. Never remove gas cap or add fuel while the engine is hot or running.
 - e. Allow engine to cool at least two minutes before refueling.
 - f. Never over fill fuel tank. Fill tank to no more than ½ inch below bottom of filler neck to provide space for fuel expansion.
 - g. Replace gasoline cap and tighten securely.
 - h. If gasoline is spilled, wipe it off the engine and equipment. Move machine to another area. Wait 5 minutes before starting the engine.
 - i. Never store the machine or fuel container inside where there is an open flame, spark or pilot light (e.g. furnace, water heater, space heater, clothes dryer etc.).
 - j. Allow machine to cool at least 5 minutes before storing.

Operation

1. Do not put hands or feet near rotating parts, in the auger/impeller housing or chute assembly. Contact with the rotating parts can amputate hands and feet.
2. The auger/impeller control lever is a safety device. Never bypass its operation. Doing so makes the machine unsafe and may cause personal injury.
3. The control levers must operate easily in both directions and automatically return to the disengaged position when released.
4. Never operate with a missing or damaged chute assembly. Keep all safety devices in place and working.
5. Never run an engine indoors or in a poorly ventilated area. Engine exhaust contains carbon monoxide, an odorless and deadly gas.
6. Do not operate machine while under the influence of alcohol or drugs.
7. Muffler and engine become hot and can cause a burn. Do not touch.
8. Exercise extreme caution when operating on or crossing gravel surfaces. Stay alert for hidden hazards or traffic.
9. Exercise caution when changing direction and while operating on slopes.
10. Plan your snow-throwing pattern to avoid discharge towards windows, walls, cars etc. Thus, avoiding possible property damage or personal injury caused by a ricochet.
11. Never direct discharge at children, bystanders and pets or allow anyone in front of the machine.
12. Do not overload machine capacity by attempting to clear snow at too fast of a rate.
13. Never operate this machine without good visibility or light. Always be sure of your footing and keep a firm hold on the handles. Walk, never run.
14. Disengage power to the auger/impeller when transporting or not in use.
15. Never operate machine at high transport speeds on slippery surfaces. Look down and behind and use care when backing up.
16. If the machine should start to vibrate abnormally, stop the engine, disconnect the spark plug wire and ground it against the engine. Inspect thoroughly for damage. Repair any damage before starting and operating.
17. Disengage all control levers and stop engine before you leave the operating position (behind the handles). Wait until the auger/impeller comes to a complete stop before unclogging the chute assembly, making any adjustments, or inspections.
18. Never put your hand in the discharge or collector openings. Always use the clean-out tool provided to unclog the discharge opening. Do not unclog chute assembly while engine is running. Shut off engine and remain behind handles until all moving parts have stopped before unclogging.
19. Use only attachments and accessories approved by the manufacturer (e.g. wheel weights, tire chains, cabs etc.).
20. If situations occur which are not covered in this manual, use care and good judgment. Contact your dealer or call (800) 520-5520 for assistance and the name of your nearest servicing dealer..

Maintenance & Storage

1. Never tamper with safety devices. Check their proper operation regularly. Refer to the maintenance and adjustment sections of this manual.
2. Before cleaning, repairing, or inspecting machine disengage all control levers and stop the engine. Wait until the auger/impeller come to a complete stop. Disconnect the spark plug wire and ground against the engine to prevent unintended starting.
3. Check bolts and screws for proper tightness at frequent intervals to keep the machine in safe working condition. Also, visually inspect machine for any damage.
4. Do not change the engine governor setting or over-speed the engine. The governor controls the maximum safe operating speed of the engine.
5. Snow thrower shave plates and skid shoes are subject to wear and damage. For your safety protection, frequently check all components and replace with original equipment manufacturer's (OEM) parts only. "Use of parts which do not meet the original equipment specifications may lead to improper performance and compromise safety!"
6. Check controls periodically to verify they engage and disengage properly and adjust, if necessary. Refer to the adjustment section in this operator's manual for instructions.
7. Maintain or replace safety and instruction labels, as necessary.
8. Observe proper disposal laws and regulations for gas, oil, etc. to protect the environment.
9. Prior to storing, run machine a few minutes to clear snow from machine and prevent freeze up of auger/impeller.
10. Never store the machine or fuel container inside where there is an open flame, spark or pilot light such as a water heater, furnace, clothes dryer etc.
11. Always refer to the operator's manual for proper instructions on off-season storage. onment.

Do not modify engine

To avoid serious injury or death, do not modify engine in any way. Tampering with the governor setting can lead to a runaway engine and cause it to operate at unsafe speeds. Never tamper with factory setting of engine governor.

Notice regarding Emissions

Engines which are certified to comply with California and federal EPA emission regulations for SORE (Small Off Road Equipment) are certified to operate on regular unleaded gasoline, and may include the following emission control systems: Engine Modification (EM) and Three Way Catalyst (TWC) if so equipped.

2

Safe Operation Practices

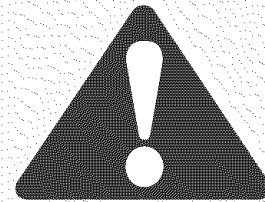

WARNING

This symbol points out important safety instructions, which if not followed, could endanger the personal safety and/or property of yourself and others. Read and follow all instructions in this manual before attempting to operate this machine. Failure to comply with these instructions may result in personal injury. When you see this symbol.

HEED IT'S WARNING!

Your Responsibility

Restrict the use of this power machine to persons who read, understand and follow the warnings and instructions in this manual and on the machine.

5

Setting Up Your Snow Thrower



NOTE: References to right or left side of the snow thrower are determined from behind the unit in the operating position (standing directly behind the snow thrower, facing the handle panel).

NOTE: Two replacement auger shear pins are included with this manual (or stowed in the plastic handle panel). Refer to Augers on page 16 for more information regarding shear pin replacement.

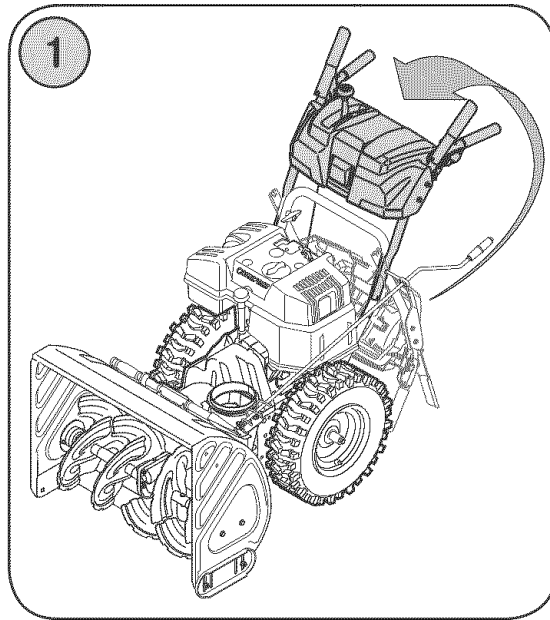

1. Observe the lower rear area of the snow thrower to be sure both cables are aligned with roller guides before pivoting the handle upward.
2. Secure the handle by tightening the plastic wing knob located on both the left and right sides of the handle. Remove and discard any rubber bands, if present. They are for packaging purposes only.
3. Position the chute assembly over the base.
4. Close the flange keepers to secure the chute assembly to the chute base. The flange keepers will click into place when properly secure.

NOTE: If the flange keepers will not easily click into place, use the palm of your hand to apply swift, firm pressure to the back of each.

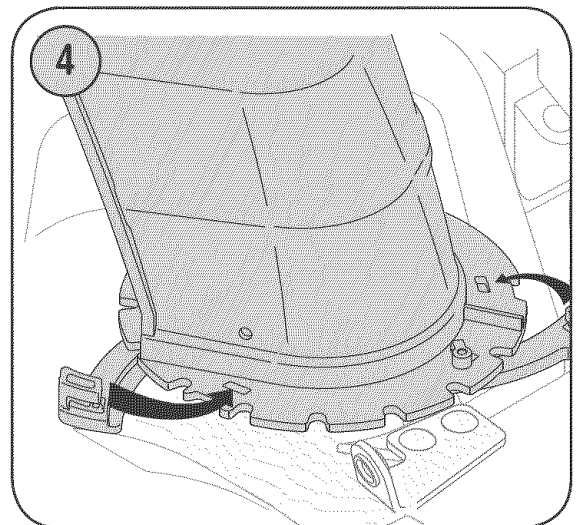
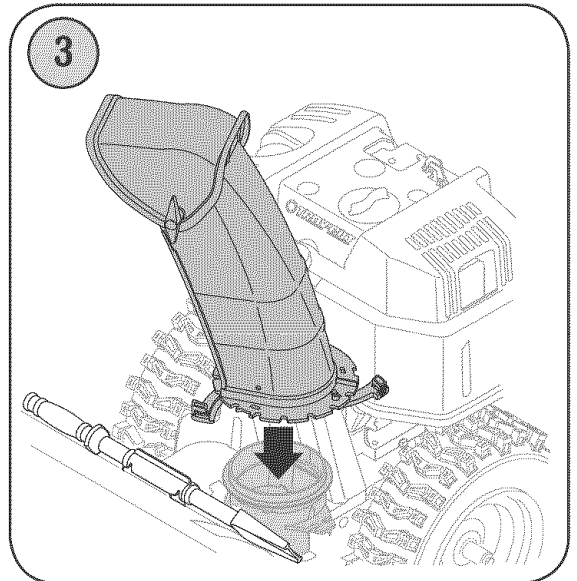
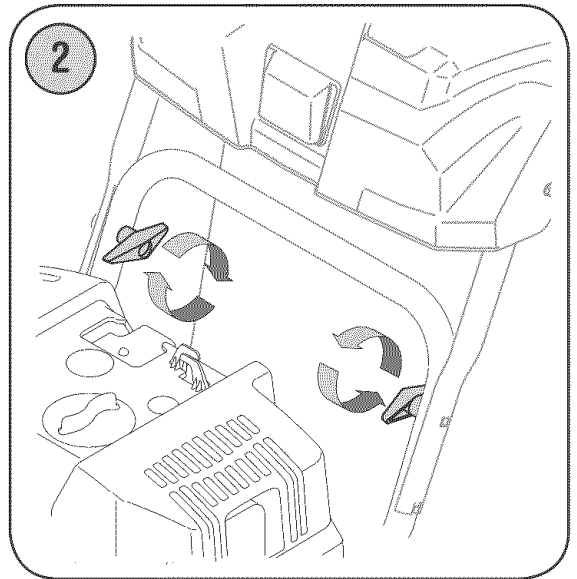

5. Remove the flat washer and hairpin clip from the end of the chute directional control.

Insert the end of the chute directional control into the lower bracket and secure with the flat washer and hairpin clip just removed. If necessary, the lower bracket can be adjusted. Refer to Chute Bracket Adjustment on Page 13.

IMPORTANT: Prior to operating your snow thrower, refer to Auger Control Test on page 11. Read and follow all instructions carefully and perform all adjustments to verify your snow thrower is operating safely and properly.

Tire Pressure

Before operating, check tire pressure and reduce pressure in both tires to between 15 psi and 20 psi.

NOTE: If the tire pressure is not equal in both tires, the unit may not travel in a straight path and the shave plate may wear unevenly.

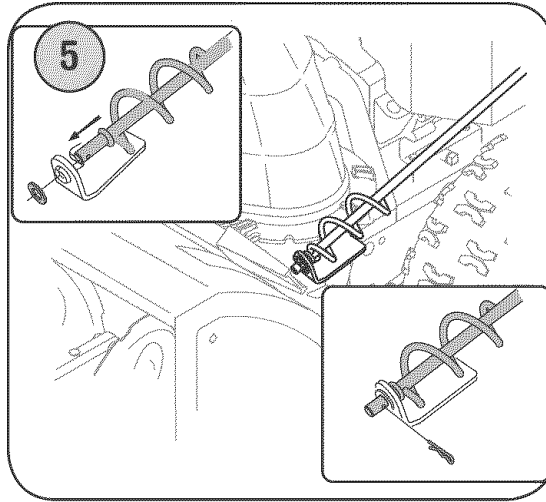

5

Setting Up Your Snow Thrower



IMPORTANT

Prior to operating your snow thrower, refer to Auger Control Test on page 11. Read and follow all instructions carefully and perform all adjustments to verify your snow thrower is operating safely and properly.

4

Operating Your Snow Thrower



WARNING

Read, understand, and follow all instructions and warnings on the machine and in this manual before operating.

Use extreme care when handling gasoline. Gasoline is extremely flammable and the vapors are explosive. **Never fuel the machine indoors or while the engine is hot or running.** Extinguish cigarettes, cigars, pipes and other sources of ignition.

Know Your Snow Thrower

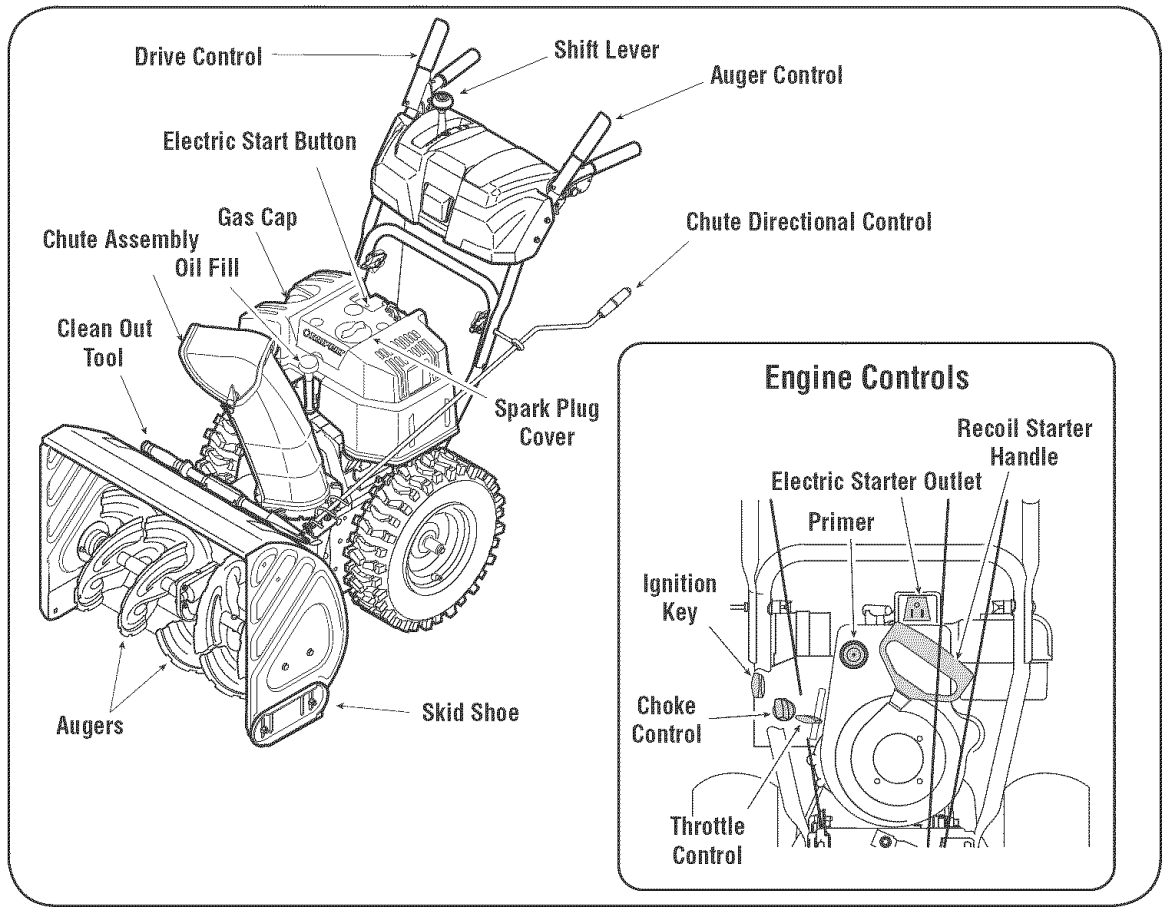

Figure 1

Now that you have set up your snow thrower for operation, get acquainted with its controls and features. These are described below and illustrated in **Figure 1**. This knowledge will allow you to use your new equipment to its fullest potential.

NOTE: For detailed starting instructions and more information on all engine controls, refer to the *Tecumseh Engines* manual packed separately and **Starting The Engine** on page 10 of this manual.

Shift Lever

The shift lever is located on the right side of the handle panel. Place the shift lever into any of eight positions to control the direction of travel and ground speed.

Forward

There are six forward (F) speeds. Position one (1) is the slowest and position six (6) is the fastest.

Reverse

There are two reverse (R) speeds. One (1) is the slower and two (2) is the faster.

- 6
- 5
- 4
- 3
- 2
- ↑
- F 1
- R 1
- R 2

Choke Control

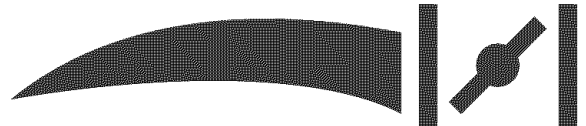

The choke control is found on the rear of the engine and is activated by rotating the knob clockwise. Activating the choke control closes the choke plate on the carburetor and aids in starting the engine.

Throttle Control

The throttle control is located on the engine. It regulates the speed of the engine and will shut off the engine when pushed down completely.

Primer

Depressing the primer forces fuel directly into the engine's carburetor to aid in cold-weather starting.

Oil Fill

Engine oil level can be checked and oil added through the oil fill.

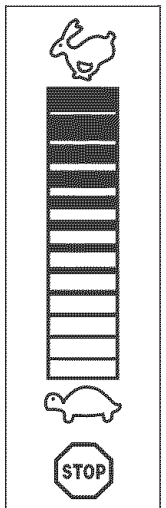

Auger Control

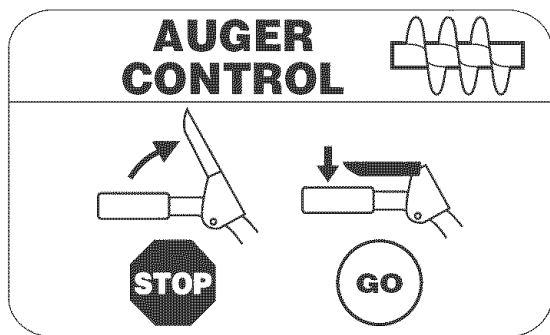

The auger control is located on the left handle. Squeeze the control grip against the handle to engage the augers and start snow throwing action. Release to stop.

Drive Control

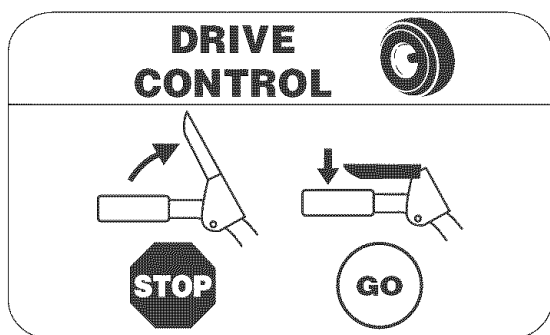

The drive control is located on the right handle. Squeeze the control grip against the handle to engage the wheel drive. Release to stop.

Chute Directional Control

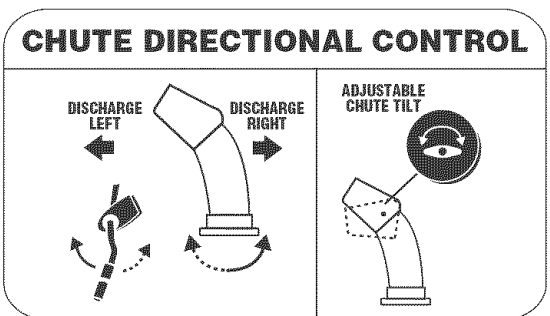

The chute directional control is located on left side of the snow thrower.

To change the direction in which snow is thrown, turn chute directional control as follows:

- Crank clockwise to discharge to the left.
- Crank counterclockwise to discharge to the right.

Ignition Key

The ignition key is a safety device. It must be fully inserted in order for the engine to start. Remove the ignition key when the snow thrower is not in use. Do not turn the ignition key in an attempt to start the engine. Doing so may cause it to break.

Clean-Out Tool



WARNING: Never use your hands to clear a clogged chute assembly. Shut off engine and remain behind handles until all moving parts have stopped before unclogging.

The chute clean-out tool is fastened to the top of the auger housing with a mounting clip. The tool is designed to clear a clogged chute assembly.

NOTE: This item is fastened with a cable tie to the rear of the auger housing at the factory. Cut the cable tie before operating the snow thrower.

Skid Shoes

Position the skid shoes based on surface conditions. Adjust upward for hard-packed snow. Adjust downward when operating on gravel or crushed rock surfaces.

Recoil Starter Handle

This handle is used to manually start the engine.

Electric Starter Button

Pressing the electric starter button engages the engine's electric starter when plugged into a 120V power source.

Electric Starter Outlet

Requires the use of a three-prong outdoor extension cord and a 120V power source/wall outlet.

Augers

When engaged, the augers rotate and draw snow into the auger housing.

Chute Assembly

Snow drawn into the auger housing is discharged out the chute assembly.

Gas Cap

Unthread the gas cap to add gasoline to the fuel tank.

Spark Plug Cover

Unscrew 1/4-turn to access the spark plug and spark plug wire.

4

Operating Your Snow Thrower



WARNING

The operation of any snow thrower can result in foreign objects being thrown into the eyes, which can damage your eyes severely. Always wear safety glasses while operating the snow thrower, or while performing any adjustments or repairs on it.

Be sure no one other than the operator is standing near the snow thrower while starting engine or operating snow thrower. Never run engine indoors or in enclosed, poorly ventilated areas. Engine exhaust contains carbon monoxide, an odorless and deadly gas. Keep hands, feet, hair and loose clothing away from any moving parts on engine and snow thrower.



WARNING

Read, understand, and follow all instructions and warnings on the machine and in this manual before operating.

Use extreme care when handling gasoline. Gasoline is extremely flammable and the vapors are explosive. Never fuel the machine indoors or while the engine is hot or running. Extinguish cigarettes, cigars, pipes and other sources of ignition.

If your home's wiring system is not a three-wire grounded system, do not use this electric starter under any conditions.

If your home electrical system is grounded, but a three-hole receptacle is not available, do not use your snow thrower's electric starter.

Gas & Oil Fill-Up

Service the engine with gasoline and oil as instructed in the Tecumseh Engines manual packed separately with your snow thrower. Read instructions carefully.

Starting The Engine

1. Attach spark plug wire to spark plug. Make certain the metal loop on the end of the spark plug wire (inside the rubber boot) is fastened securely over the metal tip on the spark plug.
2. Make certain both the auger control and drive control are in the disengaged (released) position.
3. Move throttle control up to FAST position. Insert ignition key into slot. Make sure it snaps into place. Do not attempt to turn the key.

NOTE: The engine cannot start unless the key is inserted into ignition switch.

Electric Starter

1. Determine that your home's wiring is a three-wire grounded system. Ask a licensed electrician if you are not certain.



WARNING: The optional electric starter is equipped with a grounded three-wire power cord and plug, and is designed to operate on 120 volt AC household current. It must be used with a properly grounded three-prong receptacle at all times to avoid the possibility of electric shock. Follow all instructions carefully prior to operating the electric starter.

If you have a grounded three-prong receptacle, proceed as follows:

1. Plug the extension cord into the outlet located on the engine's surface. Plug the other end of extension cord into a three-prong 120-volt, grounded, AC outlet in a well-ventilated area.
2. Rotate choke control to FULL choke position (for a cold engine start).

NOTE: If the engine is already warm, place choke control in the OFF position instead of FULL.

3. Push the primer two or three times for cold engine start, making sure to cover vent hole in the center of the primer when pushing.

NOTE: DO NOT use primer to restart a warm engine after a short shutdown.

4. Push starter button to start engine.
5. Once the engine starts, immediately release starter button.

6. As the engine warms, slowly rotate the choke control to the OFF position. If the engine falters, quickly rotate the choke control back to FULL and then slowly into the OFF position again.
7. When disconnecting the extension cord, always unplug the end at the three-prong wall outlet before unplugging the opposite end from the snow thrower.

Recoil Starter

1. Rotate choke control to FULL choke position (cold engine start).

NOTE: If the engine is already warm, place choke control in the OFF position instead of FULL.

2. Push the primer two or three times for cold engine start, making sure to cover vent hole in the center of the primer when pushing.

NOTE: DO NOT use primer to restart a warm engine after a short shutdown.

NOTE: Additional priming may be necessary if the temperature is below 15° Fahrenheit.

3. Grasp the recoil starter handle and slowly pull the rope out. At the point where it becomes slightly harder to pull the rope, slowly allow the rope to recoil.
4. Pull the starter handle with a firm, rapid stroke. Do not release the handle and allow it to snap back. Keep a firm hold on the starter handle and allow it to slowly recoil.
5. As the engine warms, slowly rotate the choke control to the OFF position. If the engine falters, quickly rotate the choke control back to the FULL position and then slowly into the OFF position again.

NOTE: Allow the engine to warm up for a few minutes after starting. The engine will not develop full power until it reaches operating temperatures.

Stopping The Engine

Run engine for a few minutes before stopping to help dry off any moisture on the engine.

- To help prevent possible starter freeze-up, proceed as follows:

Electric Starter

1. Connect extension cord to the electric starter outlet on the engine, then to 120 volt AC outlet.
2. With the engine running, push the starter button and allow the starter for spin for several seconds. The noise made by the starter is normal. The engine's starter is not being harmed.
3. When disconnecting the extension cord, always unplug the end at the three-prong wall outlet before unplugging the opposite end from the snow thrower.
4. Move throttle control to STOP position.
5. Remove the ignition key.

- Wipe all snow and moisture from the area around the engine as well as the area in and around the drive control and auger control. Also, engage and release both controls several times.

NOTE: Keep the key in a safe place. The engine cannot start without the ignition key.

Recoil Starter

- With engine running, pull starter rope with a rapid, continuous full arm stroke three or four times. Pulling the starter rope will produce a loud clattering sound, which is not harmful to engine.
- Move throttle control to STOP position.
- Remove the ignition key.

NOTE: Keep the key in a safe place. The engine cannot start without the ignition key.

- Wipe all snow and moisture from the area around the engine as well as the area in and around the drive control and auger control. Also, engage and release both controls several times.

Chute Clean-Out Tool

The chute clean-out tool is conveniently fastened to the rear of the auger housing with a mounting clip. Should snow and ice become lodged in the chute assembly during operation, proceed as follows to safely clean the chute assembly and chute opening:

- Release both the Auger Control and the Drive Control.
- Stop the engine by removing the ignition key.
- Remove the clean-out tool from the clip which secures it to the rear of the auger housing.
- Use the shovel-shaped end of the clean-out tool to dislodge and scoop any snow and ice which has formed in and near the chute assembly.
- Refasten the clean-out tool to the mounting clip on the rear of the auger housing, reinsert the ignition key and start the snow thrower's engine.
- While standing in the operator's position (behind the snow thrower), engage the auger control for a few seconds to clear any remaining snow and ice from the chute assembly.

To Engage Drive

- With the throttle control in the Fast (rabbit) position, move shift lever into one of the six forward (F) positions or two reverse (R) positions. Select a speed appropriate for the snow conditions and a pace you're comfortable with.
- Squeeze the auger control against the handle and the augers will turn. Release it and the augers will stop.
- Squeeze the drive control against the handle the snow thrower will move. Release it and drive motion will stop.

To Engage Augers

- To engage the augers and start throwing snow, squeeze the auger control against the left handle. Release to stop the augers.

Auger Control Test

Perform the following test before operating your snow thrower for the first time and at the start of each winter. Check the adjustment of the auger control as follows:

- When the auger control is released and in the disengaged "up" position, the cable should have very little slack. It should NOT be tight.
- In a well-ventilated area, start the snow thrower engine as instructed on the previous page. Make sure the throttle is set in the FAST position.
- While standing in the operator's position (behind the snow thrower), engage the auger.
- Allow the auger to remain engaged for approximately ten (10) seconds before releasing the auger control. Repeat this several times.
- With the throttle control in the FAST (rabbit) position and the auger control in the disengaged "up" position, walk to the front of the machine.
- Confirm that the auger has completely stopped rotating and shows NO signs of motion. If the auger shows ANY signs of rotating, immediately return to the operator's position and shut off the engine. Wait for ALL moving parts to stop before re-adjusting the auger control.
- To readjust the control cable, loosen the upper hex nut on the auger cable bracket.
- Position the bracket upward to provide more slack (or downward to increase cable tension). See Figure 2.
- Retighten the upper hex nut.
- Repeat **Auger Control Test** to verify proper adjustment has been achieved.

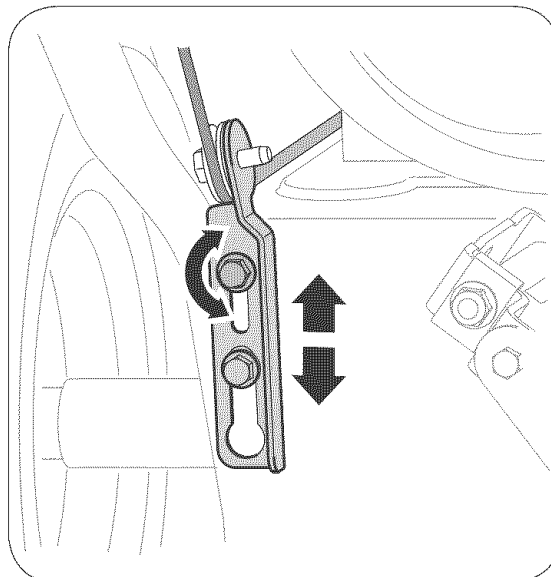

Figure 2



When selecting a Drive Speed, use the slower speeds until you are comfortable and familiar with the operation of the snow thrower.

NEVER reposition the shift lever (change speeds or direction of travel) without first releasing the drive control and bringing the snow thrower to a complete stop. Doing so will result in premature wear to the snow thrower's drive system.



WARNING

Never use your hands to clean snow and ice from the chute assembly or auger housing.

The muffler, engine and surrounding areas become hot and can cause a burn. Do not touch.

4

Making Adjustments

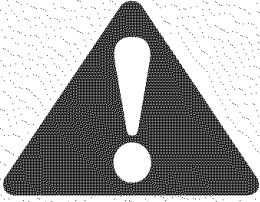

WARNING

Read, understand, and follow all instructions and warnings on the machine and in this manual before operating.

Never attempt to make any adjustments while the engine is running, except where specified in operator's manual.

Auger Control

Refer to Auger Control Test on Page 11 to adjust the auger control.

Shift Cable

If the full range of speeds (forward and reverse) cannot be achieved, refer to the figures to the right and adjust the shift cable as follows:

1. Place the shift lever in the **fastest** forward speed position.
2. Loosen the hex nut on the shift cable index bracket. See Figure 3.
3. Pivot the bracket downward to take up slack in the cable.
4. Retighten the hex nut.

Drive Control

When the drive control is released and in the disengaged "up" position, the cable should have very little slack. It should NOT be tight.

Check the adjustment of the drive control as follows:

1. With the drive control released, push the snow thrower gently forward. The unit should roll freely.
2. Engage the drive control and gently attempt to push the snow thrower forward. The wheels should not turn. The unit should not roll freely.
3. With the drive control released, move the shift lever back and forth between the R2 position and the F6 position several times. There should be no resistance in the shift lever.
4. If any of the above tests failed, the drive cable is in need of adjustment. Proceed as follows:
5. Loosen the lower hex nut on the drive cable bracket. See Figure 4.
6. Position the bracket upward to provide more slack (or downward to increase cable tension).
7. Retighten the upper hex nut.

Chute Assembly

The distance snow is thrown can be adjusted by changing the angle of the chute assembly. To do so:

1. Stop the engine by removing the ignition key and loosen the plastic wing knob found on the left side of the chute assembly.
2. Pivot the chute upward or downward before retightening the wing knob. See Figure 5.

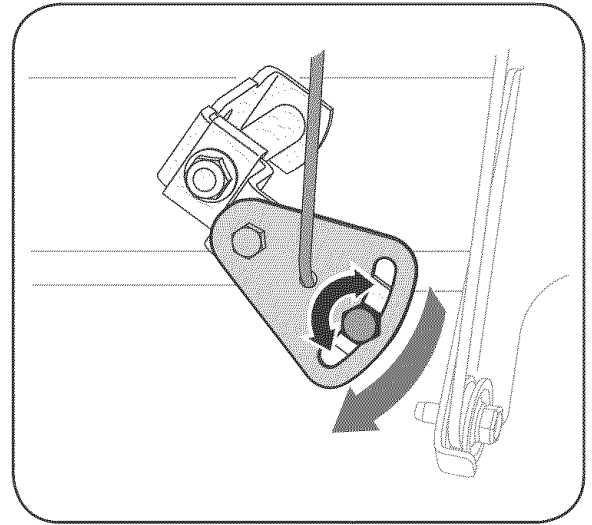

Figure 3

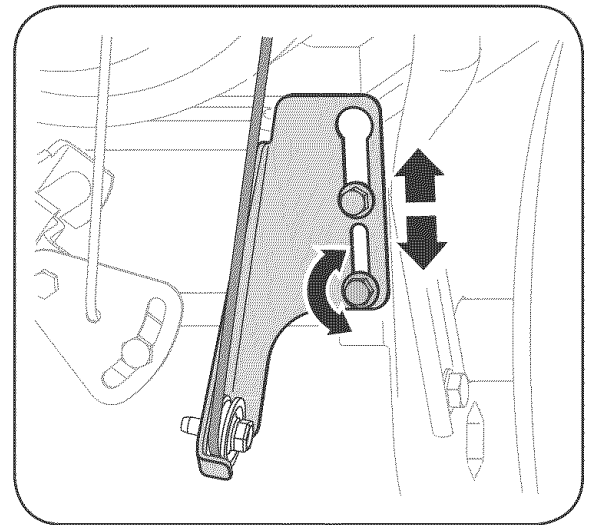

Figure 4

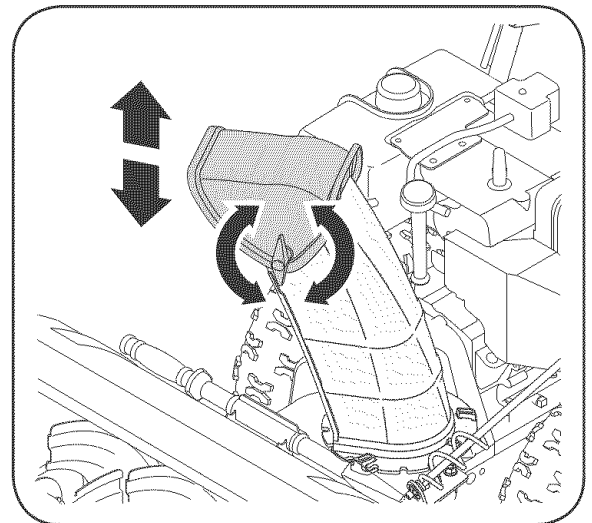

Figure 5

Skid Shoes

The space between the skid shoes and the ground can be adjusted. See Figure 6.

- For close snow removal on a smooth surface, raise skid shoes higher on the auger housing.
- Use a middle or lower position when the area to be cleared is uneven, such as a gravel driveway.

To adjust the skid shoes:

1. Loosen the four hex nuts (two on each side) and carriage bolts. Move skid shoes to desired position.
2. Make certain the entire bottom surface of skid shoe is against the ground to avoid uneven wear on the skid shoes.
3. Retighten nuts and bolts securely.

Chute Bracket Adjustment

If the spiral at the bottom of the chute directional control is not fully engaging with the chute assembly, the chute bracket can be adjusted. To do so:

1. loosen the two nuts which secure the chute bracket and reposition it slightly. See Figure 7.
2. Retightening the nuts.

Tire Pressure

Before operating, check tire pressure and reduce pressure to between 15 psi and 20 psi.

If the tire pressure is not equal in both tires, the unit may pull to one side or the other.

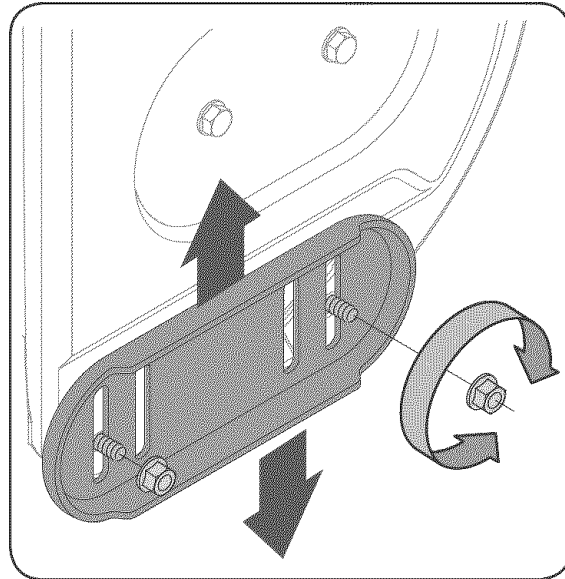

Figure 6

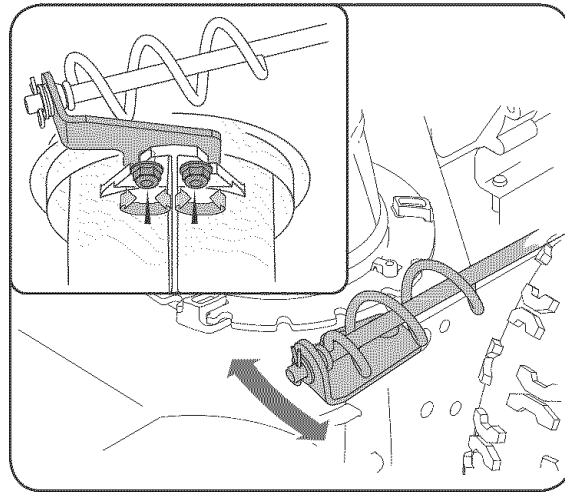
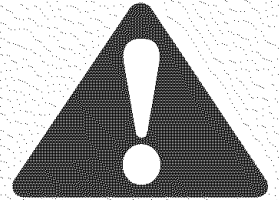

Figure 7

4

Making Adjustments



WARNING

Loose gravel can be picked up and thrown by the auger, causing injury to the operator and bystanders and/or damage to the snow thrower and surrounding property.

5

Maintaining Your Snow Thrower



WARNING

Before lubricating, repairing, or inspecting, disengage all controls and stop engine. Wait until all moving parts have come to a complete stop.



Avoid oil spillage on rubber friction wheel and aluminum drive plate.

Do not overfill the gear case. Damage to the seals could result.

Engine

Refer to the separate *Tecumseh* Engines manual packed with your unit for all engine maintenance.

Lubrication

Engine

Refer to the separate *Tecumseh* Engines manual packed with your unit for all engine lubrication instructions.

Gear Shaft

The gear (hex) shaft should be lubricated at least once a season or after every 25 hours of operation.

1. Remove the lower frame cover by removing the two screws which secure it.
2. Apply a light coating of an all-weather multi-purpose grease to the hex shaft. See Figure 8.

Wheels

At least once a season, remove both wheels. Clean and coat the axles with a multipurpose automotive grease before reinstalling wheels.

Chute Directional Control

Once a season, the joystick should be lubricated with petroleum jelly, linseed oil, mineral oil, paraffin wax or 3-in-1 oil.

Auger Shaft

At least once a season, remove the shear pins on auger shaft. Spray lubricant inside shaft, around the spacers. Also lubricate the flange bearings found at either end of the shaft. See Figure 9.

Gear Case

The auger gear case has been filled with grease at the factory. If disassembled for any reason, lubricate with two ounces of grease (Part Number 737-0168).

On models equipped with a grease fitting, use a grease gun to lubricate the auger gear case.

NOTE: Do not overfill the gear case. Damage to the seals could result. Be sure the vent plug is free of grease in order to relieve pressure.

Shave Plate and Skid Shoes

The shave plate and skid shoes on the bottom of the snow thrower are subject to wear. They should be checked periodically and replaced when necessary.

To remove skid shoes:

1. Remove the four carriage bolts and hex flange nuts which secure them to the snow thrower.
2. Reassemble new skid shoes with the four carriage bolts (two on each side) and hex flange nuts. Refer to Figure 10.

To remove shave plate:

1. Remove the carriage bolts and hex nuts which attach it to the snow thrower housing.

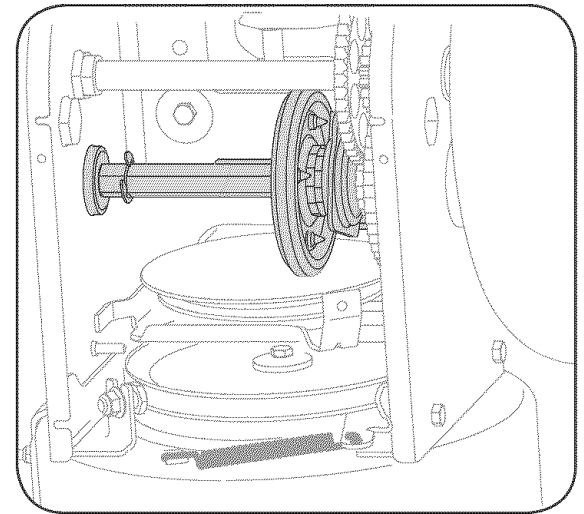

Figure 8

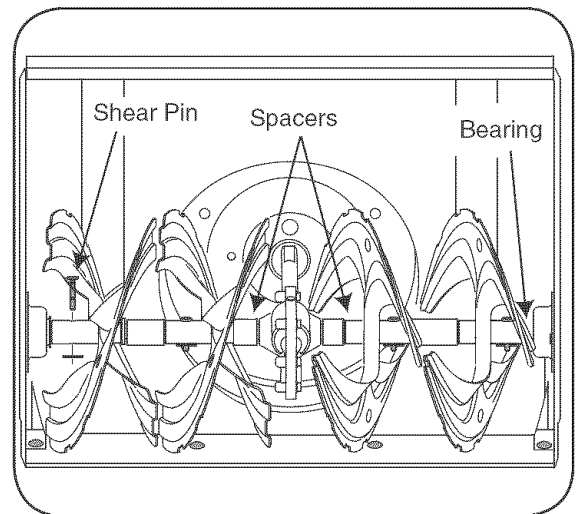

Figure 9

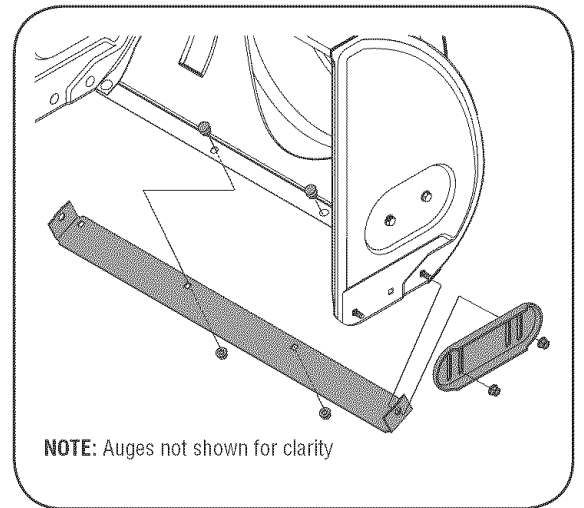

Figure 10

2. Reassemble new shave plate, making sure heads of carriage bolts are to the inside of housing. Tighten securely.

Auger Belt Replacement

To remove and replace your snow thrower's auger belt, proceed as follows:

1. Remove the plastic belt cover on the front of the engine by removing the two self-tapping screws.

NOTE: Drain the gasoline from the snow thrower, or place a piece of plastic under the gas cap.

2. Carefully pivot the snow thrower up and forward so that it rests on the auger housing. Remove the frame cover from the underside of the snow thrower by removing four self-tapping screws which secure it.
3. Roll the auger belt off the engine pulley.
4. a. Loosen and remove the shoulder screw which acts as a belt keeper.
b. Unhook the support bracket spring from the frame.
5. Remove the belt from around the auger pulley, and slip the belt between the support bracket and the auger pulley. Reassemble auger belt by following instructions in reverse order.

NOTE: Do NOT forget to reinstall the shoulder screw and reconnect the spring to the frame after installing a replacement auger belt.

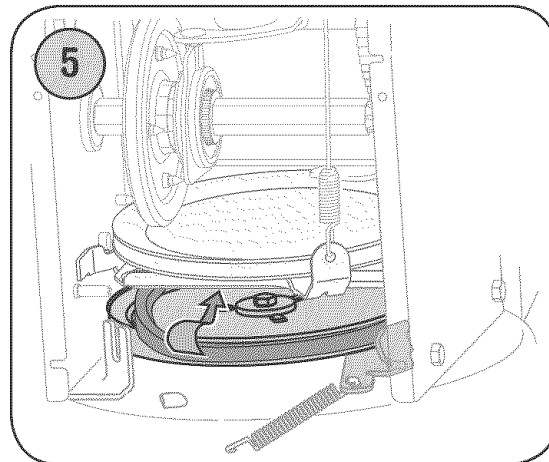
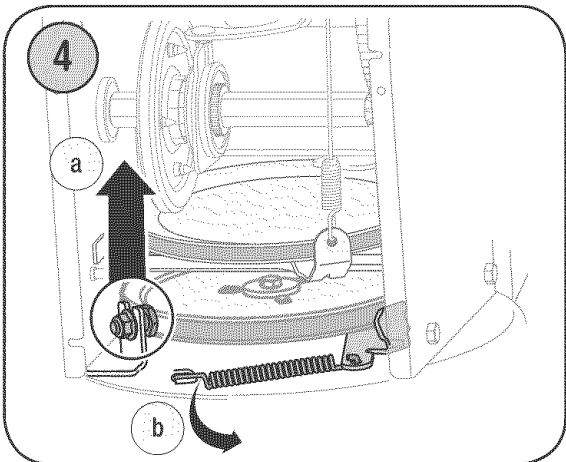
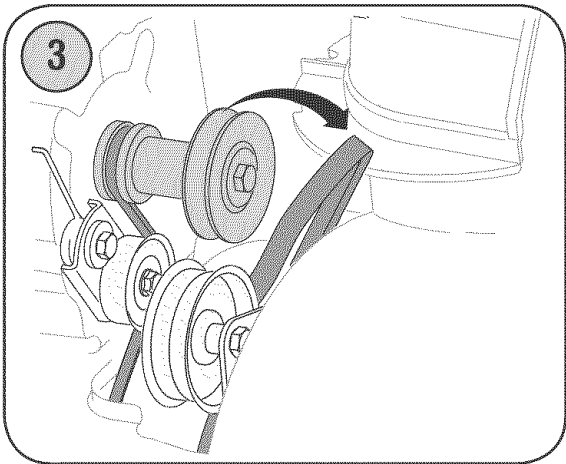
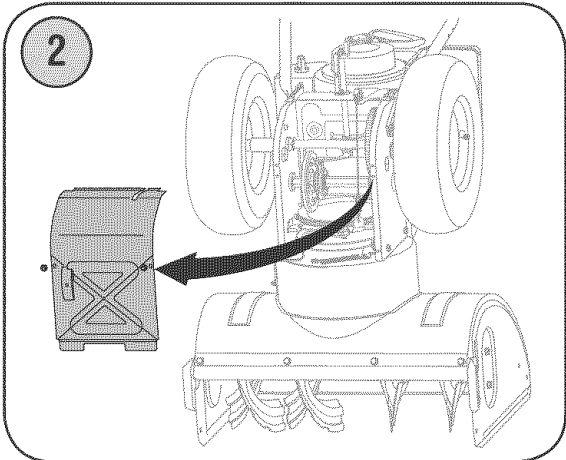
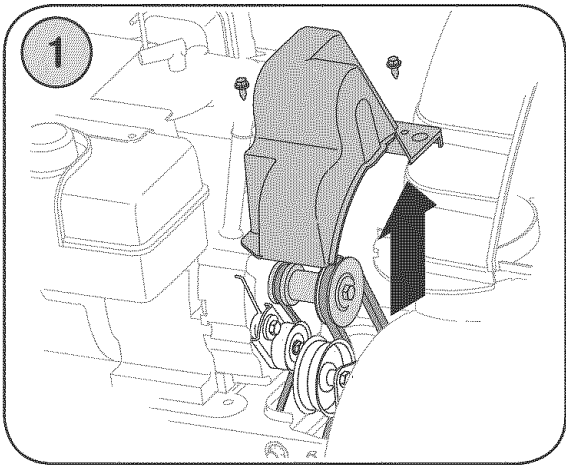

5

Maintaining Your Snow Thrower



NOTE: Although multi-viscosity oils (5W30, 10W30 etc.) improve starting in cold weather, these multi-viscosity oils also result in higher oil consumption when used above 32°F. Check your snow thrower's engine oil level more frequently to avoid possible engine damage from running low on oil.

NOTE: Do not sand-blast spark plug. Spark plug should be cleaned by scraping or wire brushing and washing with a commercial solvent.

IMPORTANT
NEVER replace the auger shear pins with standard pins. Any damage to the auger gearbox or other components, as a result of doing so, will NOT be covered by your snow thrower's warranty.

5

Maintaining Your Snow Thrower



NEVER replace the auger shear pins with anything other than OEM Part No.738-04124 replacement shear pins. Any damage to the auger gearbox or other components as a result of failing to do so will NOT be covered by your snow thrower's warranty.

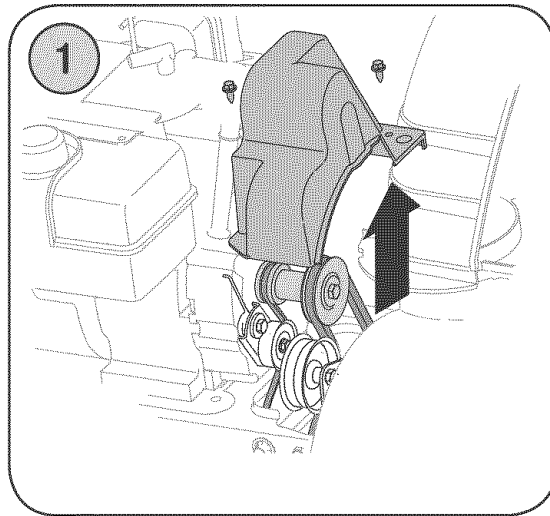

Augers

- The augers are secured to the spiral shaft with two shear pins and cotter pins. If the auger should strike a foreign object or ice jam, the snow thrower is designed so that the pins may shear. Refer to Figure 9.
- If the augers will not turn, check to see if the pins have sheared. One set of replacement shear pins has been provided with the snow thrower. When replacing pins, spray an oil lubricant into shaft before inserting new pins.

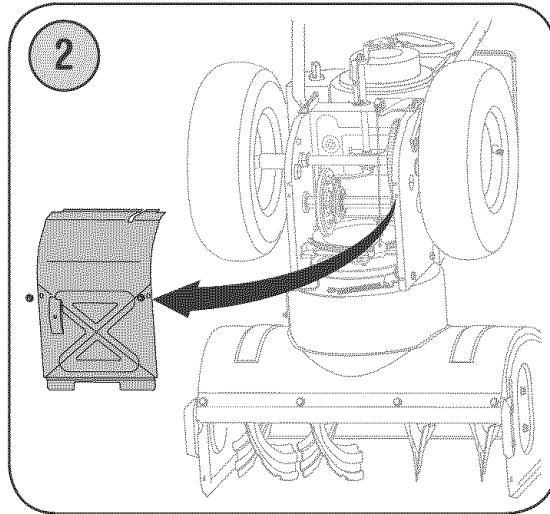

Drive Belt Replacement

To remove and replace your snow thrower's auger belt, proceed as follows:

1. Remove the plastic belt cover on the front of the engine by removing the two self-tapping screws.
- Drain the gasoline from the snow thrower, or place a piece of plastic under the gas cap.
- Carefully pivot the snow thrower up and forward so that it rests on the auger housing.
2. Remove the frame cover from the underside of the snow thrower by removing four self-tapping screws which secure it.
3. a. Grasp the idler pulley and pivot it toward the right.
b. Roll the auger belt off the engine pulley.
c. Lift the drive belt off engine pulley.
4. Slip the drive belt off the pulley and between friction wheel and friction wheel disc.
- Remove and replace belt in the reverse order.

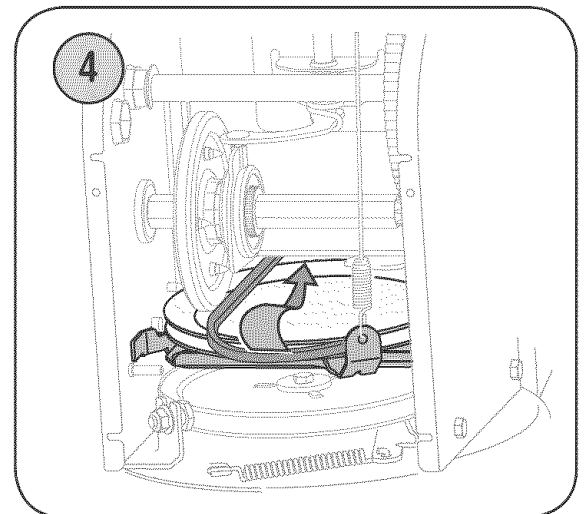
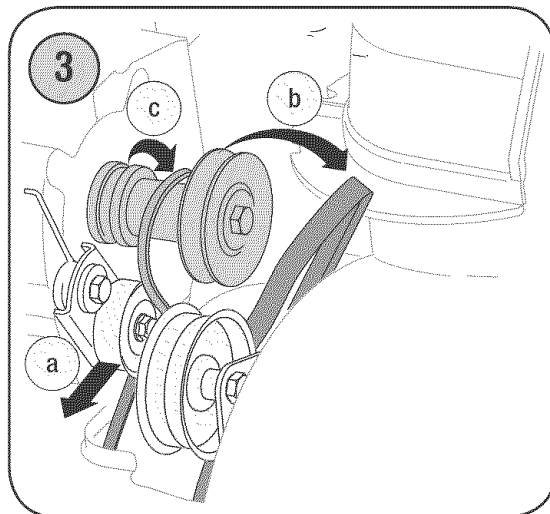

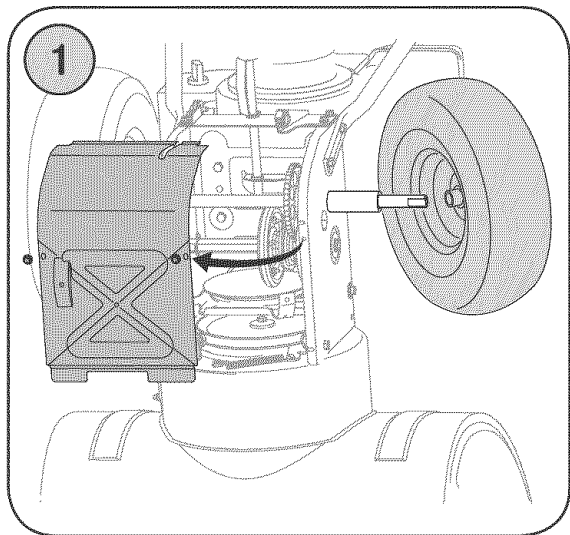

Friction Wheel Removal

If the snow thrower fails to drive with the drive control engaged, and performing the drive control cable adjustment on page 14 fails to correct the problem, the friction wheel may need to be replaced. Follow the instructions below. Examine the friction wheel for signs of wear or cracking and replace if necessary

- Place the shift lever in third Forward (F3) position.
 - Drain the gasoline from the snow thrower, or place a piece of plastic under the gas cap.
 - Carefully pivot the snow thrower up and forward so that it rests on the auger housing.
1. a. Remove the frame cover from the underside of the snow thrower by removing four self-tapping screws which secure it.
 - b. Remove the right-hand wheel by removing the screw and bell washer which secure it to the axle.
 2. Carefully remove the hex nut and washer which secures the hex shaft to the snow thrower frame and lightly tap the shaft's end to dislodge the ball bearing from the right side of the frame.
 3. Carefully position the hex shaft downward and to the left before carefully sliding the friction wheel assembly off the shaft.

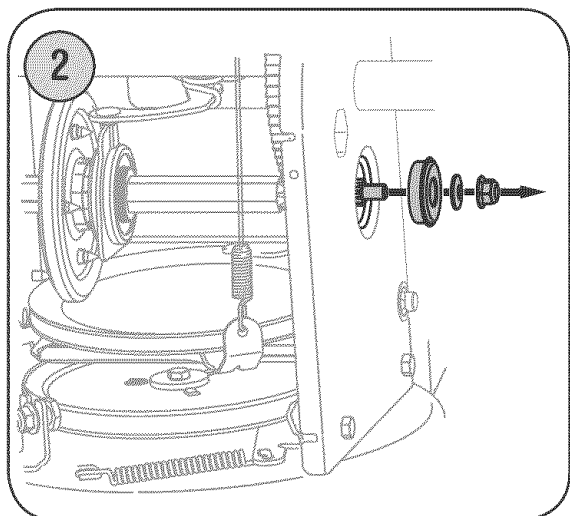

NOTE: If you're replacing the friction wheel assembly as a whole, discard the worn part and slide the new part onto the hex shaft. Follow the steps above in reverse order to reassemble components. If you're disassembling the friction wheel and replacing only the rubber ring, proceed as follows:

4. Remove the four screws which secure the friction wheel's side plates together.
 - Remove the rubber ring from between the plates.
 - Reassemble the side plates with a new rubber ring.
- Slide the friction wheel assembly back onto the hex shaft and follow the steps above in reverse order to reassemble components.

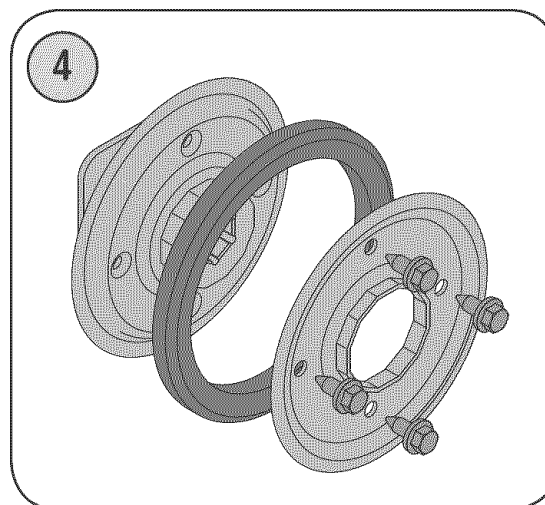
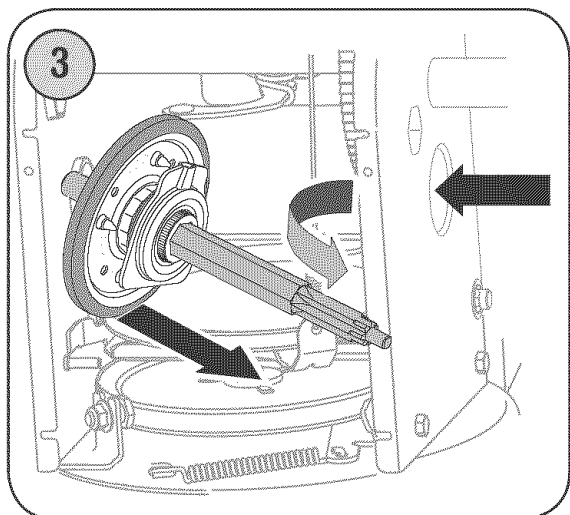

5

Maintaining Your Snow Thrower



When reassembling the friction wheel assembly, tighten each screw only one rotation before turning the wheel clockwise and proceeding with the next screw. Repeat this process several times to ensure the plates are secured with equal force.

NEVER replace the auger shear pins with anything other than OEM Part No.738-04124 replacement shear pins. Any damage to the auger gearbox or other components as a result of failing to do so will NOT be covered by your snow thrower's warranty.

7

Off-Season Storage

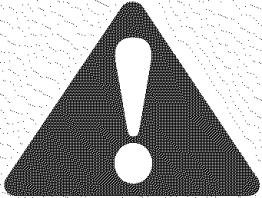

WARNING

Never store snow thrower with fuel in tank indoors or in poorly ventilated areas, where fuel fumes may reach an open flame, spark or pilot light as on a furnace, water heater, clothes dryer or gas appliance.

Drain fuel into an approved container outdoors, away from any open flame. Be certain engine is cool. Do not smoke. Fuel left in engine during warm weather deteriorates and will cause serious starting problems.

Do not drain carburetor if using fuel stabilizer. Never use engine or carburetor cleaning products in the fuel tank or permanent damage may occur.

If the snow thrower will not be used for 30 days or longer, or if it is the end of the snow season when the last possibility of snow is gone, the equipment needs to be stored properly. Follow storage instructions below to ensure top performance from the snow thrower for many more years.

Preparing Engine



WARNING: Never store snow thrower with fuel in tank indoors or in poorly ventilated areas, where fuel fumes may reach an open flame, spark or pilot light as on a furnace, water heater, clothes dryer or gas appliance.

NOTE: It is important to prevent gum deposits from forming in essential fuel system parts of the engine such as the carburetor, fuel filter, fuel hose or tank during storage.

CAUTION: Alcohol blended fuels (called gasohol or using ethanol or methanol) can attract moisture which leads to separation and formation of acids during storage. Acidic gas can damage the fuel system of an engine while in storage.

To avoid engine problems, the fuel system should be emptied before storage for 30 days or longer. Follow these instructions to prepare your snow thrower for storage:



WARNING: Drain fuel into an approved container outdoors, away from any open flame. Be certain engine is cool. Do not smoke. Fuel left in engine during warm weather deteriorates and will cause serious starting problems.

1. Remove all gasoline from the carburetor and the fuel tank to prevent gum deposits from forming on these parts and harming the engine.
2. Run the engine until the fuel tank is empty and it stops due to lack of fuel.
3. Drain carburetor by pressing upward on bowl drain, located below the carburetor cover (refer to the *Tecumseh* engine manual for more detailed instruction).



WARNING: Do not drain carburetor if using fuel stabilizer. Never use engine or carburetor cleaning products in the fuel tank or permanent damage may occur.

NOTE: Fuel stabilizer (such as STA-BIL) is an acceptable alternative in minimizing the formation of fuel gum deposits during storage. Add stabilizer to gasoline in fuel tank or storage container. Always follow mix ratio found on stabilizer container. Run engine at least 10 minutes after adding stabilizer to allow it to reach the carburetor. Do not drain carburetor if using fuel stabilizer.

4. Remove the spark plug and pour one (1) ounce of engine oil through the spark plug hole into the cylinder. Cover spark plug hole with a rag and crank the engine several times to distribute the oil. Replace spark plug.

NOTE: Refer to the *Tecumseh* engine manual for more information on preparing the snow thrower engine for storage.

Preparing Snow Thrower

1. When storing the snow thrower in an unventilated or metal storage shed, care should be taken to rustproof the equipment. Using a light oil or silicone, coat the equipment, especially any chains, springs, bearings and cables.
2. Remove all dirt from exterior of engine and equipment.
3. Follow lubrication recommendations on page 12.
4. Store equipment in a clean, dry area.

Problem	Cause	Remedy
Engine fails to start	<ol style="list-style-type: none"> 1. Choke not in ON position. 2. Spark plug wire disconnected. 3. Fuel tank empty or stale fuel. 4. Engine not primed. 5. Faulty spark plug. 6. Blocked fuel line. 7. Safety key not in ignition on engine. 	<ol style="list-style-type: none"> 1. Move choke to ON position. 2. Connect wire to spark plug. 3. Fill tank with clean, fresh gasoline. 4. Prime engine as instructed in "Operating Your Snow Thrower". 5. Clean, adjust gap, or replace. 6. Clean fuel line. 7. Insert key fully into the switch.
Engine runs erratic	<ol style="list-style-type: none"> 1. Unit running on CHOKE. 2. Blocked fuel line or stale fuel. 3. Water or dirt in fuel system. 4. Carburetor out of adjustment. 	<ol style="list-style-type: none"> 1. Move choke lever to OFF position. 2. Clean fuel line; fill tank with clean, fresh gasoline. 3. Drain fuel tank. Refill with fresh fuel. 4. Contact Troy-Bilt Service Center.
Engine overheats	<ol style="list-style-type: none"> 1. Carburetor not adjusted properly. 	<ol style="list-style-type: none"> 1. Contact Troy-Bilt Service Center.
Excessive Vibration	<ol style="list-style-type: none"> 1. Loose parts or damaged auger. 	<ol style="list-style-type: none"> 1. Stop engine immediately and disconnect spark plug wire. Tighten all bolts and nuts. If vibration continues, have unit serviced by a Troy-Bilt Service Center.
Loss of power	<ol style="list-style-type: none"> 1. Spark plug wire loose. 2. Gas cap vent hole plugged. 3. Exhaust port plugged. 	<ol style="list-style-type: none"> 1. Connect and tighten spark plug wire. 2. Remove ice and snow from gas cap. Be certain vent hole is clear. 3. Contact Troy-Bilt Service Center.
Unit fails to propel itself	<ol style="list-style-type: none"> 1. Drive control cable in need of adjustment. 2. Drive belt loose or damaged. 	<ol style="list-style-type: none"> 1. Adjust drive control cable. Refer to "Making Adjustments". 2. Replace drive belt.
Unit fails to discharge snow	<ol style="list-style-type: none"> 1. Chute assembly clogged. 2. Foreign object lodged in auger. 3. Auger control cable in need of adjustment. 4. Auger belt loose or damaged. 5. Shear pin(s) sheared. 	<ol style="list-style-type: none"> 1. Stop engine immediately and disconnect spark plug wire. Clean chute assembly and inside of auger housing with clean-out tool or a stick. 2. Stop engine immediately and disconnect spark plug wire. Remove object from auger with clean-out tool or a stick. 3. Refer to "Auger Control Test" on page 11. 4. Refer to Maintenance section. 5. Replace with new shear pin(s).

8

Trouble-Shooting



NOTE: This section addresses minor service issues. For further details, contact a Troy-Bilt authorized service center or call 1 (800) 520-5520 for assistance.

1.	731-2635	Snow Removal Tool Mount
2.	684-04057	Impeller Assembly, 12" Dia.
3.	710-0347	Hex Screw, 3/8-16, 1.75, Gr5
4.	710-0451	Bolt, Carriage, 5/16-18, .750 Gr1
5.	710-0604A	Screw, 5/16-18, 0.625
6.	710-0703	Screw, Carriage, 1/4-20, .750, Gr5
7.	712-04063	Nut, Flange Lock, 5/16-18, Nylon
8.	712-04064	Nut, Flange Lock, 1/4-20, Nylon
9.	712-04065	Nut, Flange Lock, 3/8-16, Nylon
10.	714-04040	Cotter Pin, Bow-tie
11.	725-0157	Cable, Tie, 3/16 x .05 x 7.4
12.	726-04012	Nut, Push-on, .25 Dia
13.	731-04705	Chute, Adapter 5" Dia
14.	732-0611	Spring, Extension, .38 OD x 3.6
15.	736-0174	Washer, Wave, .625 x .885 x .015
16.	736-0242	Washer, Bell, .340 x .872 x .060
17.	736-0463	Washer, Flat, .25 x .630 x .0515
18.	731-2643	Snow Removal Tool
19.	738-0143	Screw, Shoulder, .498 x .34, 3/8-16
20.	738-0281	Screw, Shoulder, .625 x .17, 3/8-16
21.	738-04124A	Shear Pin, .25 x 1.50
22.	741-0245	Bearing, Hex Flange x .75 ID
23.	741-0309	Bearing, Ball, .75 ID x 1.85 OD
24.	756-0981A	Flat Pulley, Idler, 2.75 OD
25.	790-00075	Housing, Bearing, 1.85 ID
26.	790-00080	Bracket, Auger Idler w/ Brake
27.	618-04192	Gearbox Ass'y w/ Fitting, Auger
	618-04172	Gearbox Ass'y w/o Fitting, Auger
28.	684-04078	Housing Ass'y, Troy-Bilt, Auger 26"

29.	684-04107	Spiral Assembly, LH
30.	684-04108	Spiral Assembly, RH
31.	731-04870	Spacer, 1.25 OD x .75 ID x 1.00
32.	736-0188	Washer, Flat, .76 x 1.49 x .06
33.	741-0493A	Bushing, Flange, .80 ID x .91 OD
34.	790-00138A	Bearing Housing w/ Hole, 1" Hex
	790-00087A	Bearing Housing w/o Hole, 1" Hex
35.	790-00121	Shave Plate, 2.25 x 25.66
36.	790-00091	Slide Shoe, Deluxe
37.	719-0319	Housing, Auger, RH Reducer
38.	719-0320	Housing, Auger, LH Reducer
39.	721-0179	Seal, Oil, .750 ID
40.	741-0662	Bearing, Flange, .75 x 1.0 x .59
41.	710-0642	Screw, Self-tapping, 1/4-20, 0.750
42.	711-04284	Axle, Auger, 26"
43.	714-0161	Key, Hi-pro 3/16 x 5/8
44.	715-04021	Pin, Dowel, .25 OD x 1.2
45.	717-04126	Shaft, Worm .75 OD
46.	717-0528A	Gear, Worm 20T
47.	718-04071	Collar, Thrust
48.	721-0325	Plug, 1/4 x .437
49.	721-0327	Seal, Oil, .75 x 1 x .131
50.	736-0351	Washer, Flat, .760 ID x 1.5 OD
51.	736-3084	Washer, Flat, .51 x 1.12
52.	741-0663	Bearing, Flange, .75 x 1.0 x .925
53.	741-0661A	Bearing, Flange, .75 x 1.00 x .975
54.	746-04230	Clutch Cable, Auger, 47.23"
55.	629-0071	Extention Cord, 110V
56.	737-3000	Grease Fitting, 3/16"

5

Illustrated Parts List

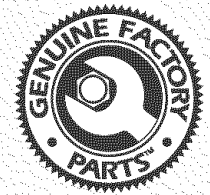

To order replacement
parts, contact
1-800-800-7310,
or visit
www.mtdproducts.com.

Style O

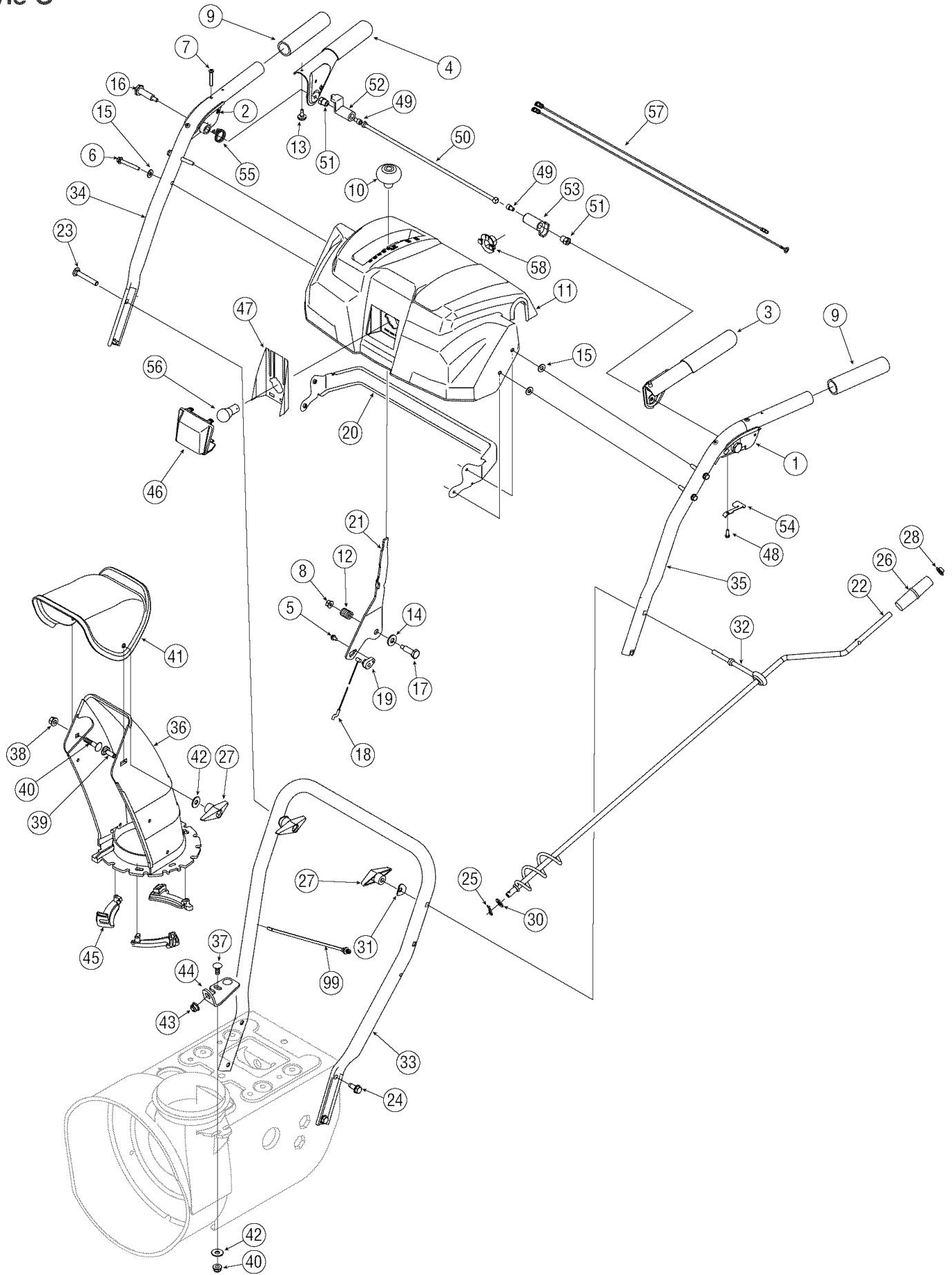

1.	631-04133	Handle Assembly, Lock, LH
2.	631-04134A	Handle Assembly, Lock, RH
3.	684-04105A	Handle Ass'y, Engagement LH
4.	684-04106A	Handle Ass'y, Engagement, RH
5.	710-0224	Screw, #10-16, 0.500
6.	710-1026	Screw, 1/4-20, 1.750
7.	710-1233	Screw, Machine, #10-24, 1.375
8.	712-04064	Nut, Flange Lock, 1/4-20, Nylon
9.	720-0274	Grip, 1.0 ID x 5.0
10.	720-04039	Knob, Shift
11.	731-05333	Handle Panel, O-Style
12.	732-0193	Spring, .39 x .60 x .88
13.	735-0199A	Bumper, Rubber, .62 OD x .22
14.	736-0262	Washer, Flat, .385 x .870 x .092
15.	736-0463	Washer, Flat, .25 x .630 x .0515
16.	738-04122	Screw, Shoulder, .43 x 1.34, 1/4-20
17.	738-04125	Screw, Shoulder, .374 Dia. x 1.05
18.	746-04227	Cable, Speed Selector
19.	746-0605	Barrel Holder, Cable, LH
20.	790-00140	Bracket, Panel
21.	790-00203	Lever, Shift
22.	684-04104	Crank Assembly, Chute
23.	710-0449	Screw, Carriage, 5/16-18, 2.25
24.	710-1260A	Screw, 5/16-18, 0.75, Gr5
25.	714-0104	Pin, Cotter, .072 x 1.13
26.	720-0201A	Crank Knob, 1.0 Dia. x 3.2, Black
27.	720-0284	Knob Assembly, Wing Nut, 5/16-18
28.	726-0100	Cap, Push, 3/8 Rod
29.	735-0234	Grommet, .44 ID x .94 OD x .50

30.	736-0185	Washer, Flat, .375 x .738 x .063
31.	736-0451	Washer, Saddle, 320 x .93 x .060
32.	747-04263	Eye Bolt, Chute Crank
33.	749-04138	Handle, Lower
34.	749-04141	Handle, Upper, RH
35.	749-04142	Handle, Upper, LH
36.	731-04912A	Chute, Lower, 5.0 Diameter
37.	710-0276	Bolt, Carriage, 5/16-18, 1.0
38.	712-04063	Nut, Flange Lock, 5/16-18, Nylon
39.	710-04071	Bolt, Carriage, 5/16-18, 1.0
40.	710-0451	Bolt, Carriage, 5/16-18, .750
41.	731-04426A	Chute, Upper, w/ Label
42.	736-0159	Washer.349 ID x .879 OD x .063
43.	741-0475	Bushing, Plastic, .380
44.	784-5647	Bracket, Chute Crank
45.	731-04869	Flange Keeper, Chute
46.	731-05319	Lens
47.	777X41805	Reflector Label, Lens
48.	710-04326	Screw, #8-16 x 0.50
49.	710-04354	Screw, 1/4-20 x.375
50.	711-04287	Pivot Rod
51.	712-04081A	Shoulder Nut, 1/4-20
52.	731-04894A	Lock Plate
53.	731-04896A	Clutch Lock Cam
54.	732-04219	Clutch Lock Spring
55.	732-04238	Torsion Spring
56.	725-04213	Lamp
57.	725-04214	Wire Harness
58.	725-1649	Light Socket

5

Illustrated Parts List



To order replacement
parts, contact
1-800-800-7310,
or visit
www.mtdproducts.com.

Style O

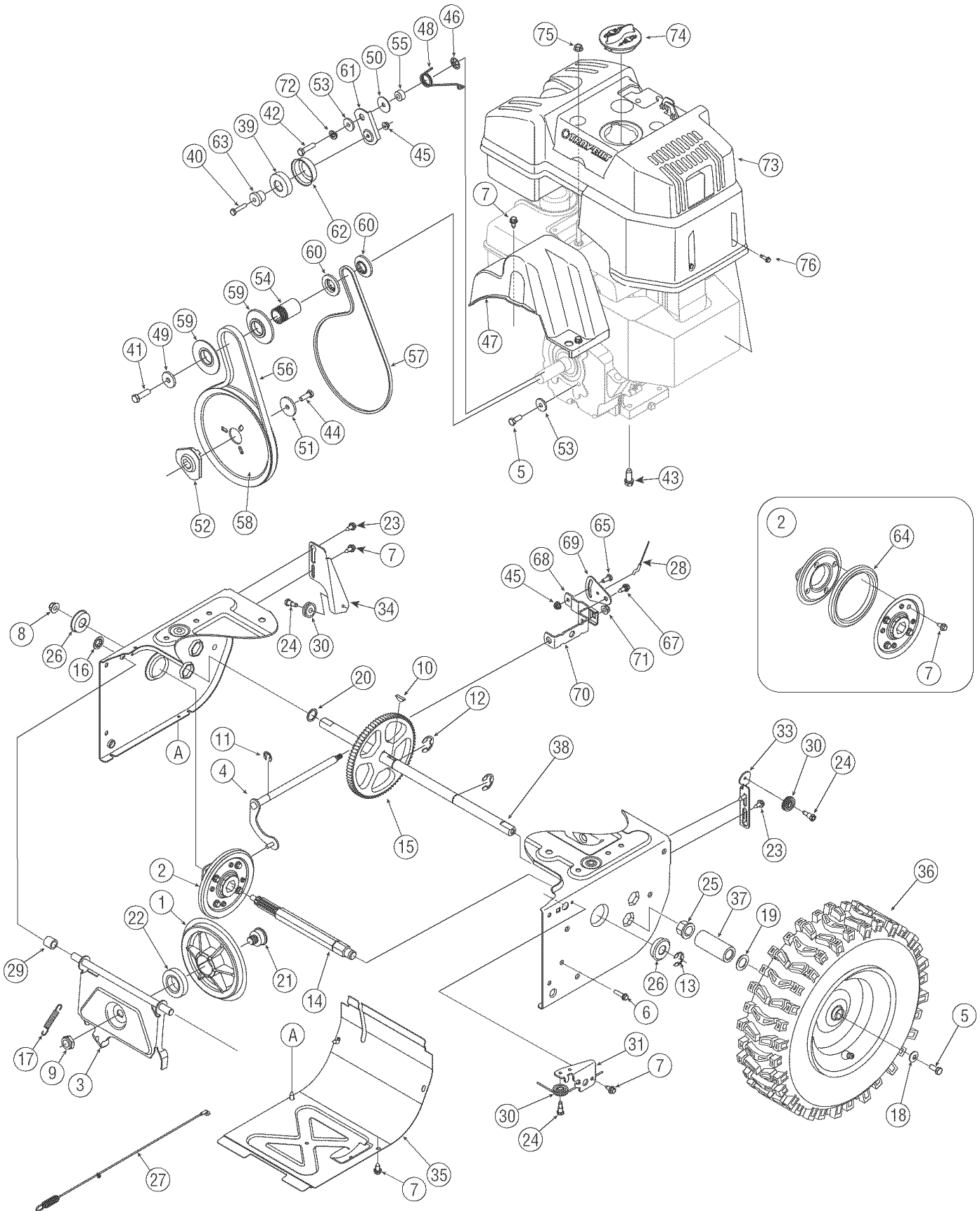

1.	756-04177	Disc, Friction Wheel
2.	684-04153	Friction Wheel Assembly, 5.5 OD
3.	684-04154	Support Bracket, Friction Wheel
4.	684-04156	Shift Assembly, Rod
5.	710-0627	Hex Screw, 5/16-24, .750, Gr5
6.	710-0788	Screw, 1/4-20, 1.000
7.	710-0896	Screw, 1/4-14 x .625
8.	712-04065	Nut, Flange Lock, 3/8-16, Nylon
9.	712-0413	Nut, Jam Lock, 5/8-18, Gr5, Nylon
10.	714-0126	Key, Hi Pro, 3/16 x 3/4 Dia.
11.	716-0104	E-ring, .500 Dia.
12.	716-0136	E-ring, Retaining, .875 Dia.
13.	716-0231	E-ring, .750 Dia.
14.	717-04209	Hex Shaft, .8125, 7-Tooth
15.	717-04230	Gear, 80-Tooth
16.	726-0221	Speed Nut, .500
17.	732-0264	Extension Spring
18.	736-0242	Washer, Bell, .340 x .872 x .060
19.	736-0287	Washer, Flat, .793 x 1.24 x .060
20.	736-04161	Washer, Flat, .75 x 1.00 x .060
21.	738-04164	Pin, Friction Disc
22.	741-04098	Ball Bearing, 30 x 55 x 13
23.	738-04184	Screw, Shoulder, .37 x .105, 1/4-20
24.	738-0924	Screw, 1/4-28, .375
25.	741-0245	Bearing, Hex Flange x .75 ID
26.	741-0563	Bearing, Ball, 17 x 40 x 12
27.	746-04229	Clutch Cable, Wheel, 44.95"
28.	746-04230	Clutch Cable, Auger, 47.23"
29.	748-0190	Spacer, .508 ID x .75 OD x .68
30.	756-0625	Roller, Cable
31.	790-00096	Front Guide Bracket, Auger Cable
32.	790-00180	Frame
33.	790-00206	Guide Bracket, Auger Cable
34.	790-00207	Guide Bracket, Drive Cable
35.	790-00226	Cover, Frame
36.	See Chart	Wheel Assembly
37.	731-04873	Spacer, 1.25 x .75 x 3.0
38.	738-04168	Axle, .75 x 22"

39.	741-0919	Ball Bearing
40.	710-0106	Hex Screw, 1/4-20, 1.25, Gr5
41.	710-0191	Hex Screw, 3/8-24, 1.25, Gr8
42.	710-0672	Hex Screw, 5/16-24, 1.25, Gr5
43.	710-0654A	Screw, Sems, 3/8-16, 1.00
44.	710-1245B	Hex Screw, 5/16-24, .875, Gr8
45.	712-04064	Nut, Flange Lock, 1/4-20, Nylon
46.	726-04012	Nut, Push-on, .25 Dia.
47.	731-05353	Cover, Belt
48.	732-04308A	Spring, Torsion, .850 ID x .354
49.	736-0247	Washer, Flat, .406 x 1.25 x .157
50.	736-0362	Washer, Flat, .330 x 1.25 x .06
51.	736-0505	Washer, Flat, .34 x 1.50 x .150
52.	748-04053	Pulley, Adapter, .75 Dia.
53.	748-04112	Spacer, Shoulder
54.	750-04303	Spacer, .875 ID x 1.185 OD
55.	750-04477	Spacer, .340 x .750 x .360
56.	754-04050	Belt, Auger Drive
57.	754-04088	Belt, Wheel Drive
58.	756-04109	Pulley, Auger Drive, 8.1 x .5
59.	756-04113	Pulley, Half, 2.6 OD
60.	756-04179	Pulley, Half, 1.5 OD
61.	790-00208	Idler Bracket, Wheel Drive
62.	790-00230	Sleeve, Bearing Idler
63.	750-04571	Spacer, Shoulder, .26 x .79 x .538
64.	735-04054	Rubber, Friction Wheel, 5.5 OD
65.	710-0751	Hex Screw, 1/4-20, .620, Gr5
66.	732-04311	Spring, Torsion, .750 ID x .968
67.	738-04184	Screw, Shoulder, .37 x .105, 1/4-20
68.	790-00156	Bracket, Shift Spacer
69.	790-00217	Pivot Bracket, Speed Selector
70.	790-00218	Shift Bracket, Speed Selector
71.	712-04063	Nut, Flange Lock, 5/16-18, Nylon
72.	736-0119	Washer, Lock, 5/16
73.	731-04049A	Engine Shroud, Troy-Bilt
74.	684-04011	Cap, Spark Plug Access
75.	712-3004A	Nut, Flange Lock, 5/16-18, GR5
76.	710-04082	Screw, #10-16, .75

Wheel Assembly	Side	Wheel Size	Rim Only	Tire Only	Valve Only
634-04147A	Left-Hand	15 x 5 x 6	634-04151	734-04012	734-0255
634-04148A	Right-Hand	15 x 5 x 6	634-04151	734-04012	734-0255

5

Illustrated Parts List



To order replacement parts, contact
1-800-800-7310,
or visit
www.mtdproducts.com.

NOTES

NOTES

MANUFACTURER'S LIMITED WARRANTY FOR



The limited warranty set forth below is given by Troy-Bilt LLC with respect to new merchandise purchased and used in the United States and/or its territories and possessions, and by MTD Products Limited with respect to new merchandise purchased and used in Canada and/or its territories and possessions (either entity respectively, "Troy-Bilt").

"Troy-Bilt" warrants this product (excluding its normal wear parts as described below) against defects in material and workmanship for a period of two (2) years commencing on the date of original purchase and will, at its option, repair or replace, free of charge, any part found to be defective in materials or workmanship. This limited warranty shall only apply if this product has been operated and maintained in accordance with the Operator's Manual furnished with the product, and has not been subject to misuse, abuse, commercial use, neglect, accident, improper maintenance, alteration, vandalism, theft, fire, water, or damage because of other peril or natural disaster. Damage resulting from the installation or use of any part, accessory or attachment not approved by Troy-Bilt for use with the product(s) covered by this manual will void your warranty as to any resulting damage.

Normal wear parts are warranted to be free from defects in material and workmanship for a period of thirty (30) days from the date of purchase. Normal wear parts include, but are not limited to items such as: batteries, belts, blades, blade adapters, grass bags, rider deck wheels, seats, snow thrower skid shoes, friction wheels, shave plates, auger spiral rubber and tires.

HOW TO OBTAIN SERVICE: Warranty service is available, WITH PROOF OF PURCHASE, through your local authorized service dealer. To locate the dealer in your area:

In the U.S.A.

Check your Yellow Pages, or contact Troy-Bilt LLC at P.O. Box 361131, Cleveland, Ohio 44136-0019, or call 1-866-840-6483 or 1-330-558-7220, or log on to our Web site at www.troybilt.com.

In Canada

Contact MTD Products Limited, Kitchener, ON N2G 4J1, or call 1-800-668-1238 or log on to our Web site at www.mtdcanada.com.

This limited warranty does **not** provide coverage in the following cases:

- a. The engine or component parts thereof. These items may carry a separate manufacturer's warranty. Refer to applicable manufacturer's warranty for terms and conditions.
- b. Log splitter pumps, valves, and cylinders have a separate one-year warranty.
- c. Routine maintenance items such as lubricants, filters, blade sharpening, tune-ups, brake adjustments, clutch adjustments,

deck adjustments, and normal deterioration of the exterior finish due to use or exposure.

- d. Service completed by someone other than an authorized service dealer.
- e. Troy-Bilt does not extend any warranty for products sold or exported outside of the United States and/or Canada, and their respective possessions and territories, except those sold through Troy-Bilt's authorized channels of export distribution.
- f. Replacement parts that are not genuine Troy-Bilt parts.
- g. Transportation charges and service calls.
- h. If Products are used commercially. (Troy-Bilt may separately offer Limited Commercial Warranties on certain select products. Ask your dealer or retailer for details or contact Troy-Bilt Service for more information).

No implied warranty, including any implied warranty of merchantability of fitness for a particular purpose, applies after the applicable period of express written warranty above as to the parts as identified. No other express warranty, whether written or oral, except as mentioned above, given by any person or entity, including a dealer or retailer, with respect to any product, shall bind Troy-Bilt. During the period of the warranty, the exclusive remedy is repair or replacement of the product as set forth above.

The provisions as set forth in this warranty provide the sole and exclusive remedy arising from the sale. Troy-Bilt shall not be liable for incidental or consequential loss or damage including, without limitation, expenses incurred for substitute or replacement lawn care services or for rental expenses to temporarily replace a warranted product.

Some states do not allow the exclusion or limitation of incidental or consequential damages, or limitations on how long an implied warranty lasts, so the above exclusions or limitations may not apply to you.

In no event shall recovery of any kind be greater than the amount of the purchase price of the product sold. **Alteration of safety features of the product shall void this warranty.** You assume the risk and liability for loss, damage, or injury to you and your property and/or to others and their property arising out of the misuse or inability to use the product.

This limited warranty shall not extend to anyone other than the original purchaser or to the person for whom it was purchased as a gift.

HOW STATE LAW RELATES TO THIS WARRANTY: This limited warranty gives you specific legal rights, and you may also have other rights which vary from state to state.

IMPORTANT: Owner must present Original Proof of Purchase to obtain warranty coverage.

**Troy-Bilt LLC, P.O. BOX 361131 CLEVELAND, OHIO 44136-0019; Phone: 1-866-840-6483, 1-330-558-7220
MTD Canada Limited - KITCHENER, ON N2G 4J1; Phone 1-800-668-1238**