

TGM 2 GRILLE MOUNT WHOLE-HOUSE ELECTRONIC AIR CLEANER

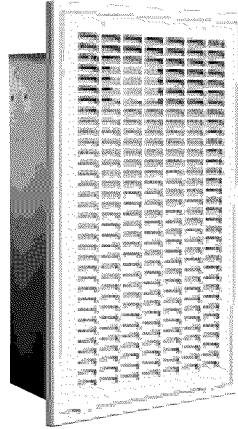

Trion's TGM 2 improves the quality of recirculated air in homes and building where induct air cleaning systems are not feasible. It is suited for either vertical or horizontal installation in wall, ceiling, or closet returns. The TGM 2 is a powerful unit which features tilt-out collection cell trays, a high frequency "pulse" power supply, and an exclusive step-down power selection system. It comes with a 120-day dealer labor allowance, and a 2-year limited warranty.

FEATURES/BENEFITS

- Available in 1000 and 2000 CFM - offers dealers a variety of optional applications
- New Spring Release Cell Retainers - allows for easy cell removal in minimal space
- Fits Between 16" Stud or Joist Centers - offers easy installation
- Removable grille - allows for thorough cleaning
- Internal Wiring Compartment - makes field wiring easy
- Aluminum and Stainless Steel Ionizing Collecting Cells - compact and lightweight for convenient removal and cleaning

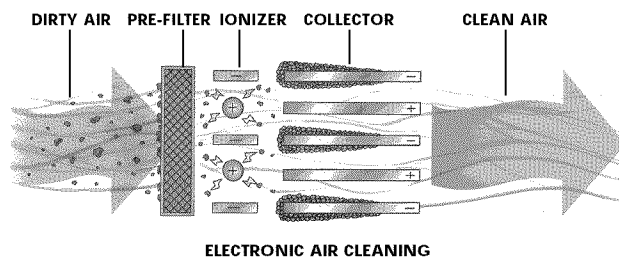

How It Works

The TGM 2 utilizes the principle of Electrostatic Precipitation. Air is drawn through the metal mesh pre-filter which traps lint and large dust particles. The remaining particles, some as small as 0.01 microns, pass into a strong electrical field (ionizing section) where the particulate receives an electrical charge. The charged particles then pass into a collector plate section made up of a series of equally spaced parallel plates. Each alternate plate is charged with the same polarity as the particles, which repel, while the interleaving plates are grounded, which attract and collect.

TRION®

SPECIFICATIONS

TGM 2 G RILLE M OUNT • E LECTRONIC A I R C LEANER

PART N O. 440657-001
 RATED A I R F L O W : 1000 cfm/ 1700m³/hr.
 M A X . P R E S S U R E D R O P : .13 in. w.g. @ 1000 CFM/
 32.3 Pa @ 1700 m³/hr.
 C E L L W E I G H T : (1) 10 Lbs./ 4.5 kg.
 S H I P P I N G W E I G H T : 37 Lbs./ 16.8 kg.
 P O W E R C O N S U M P T I O N : 40 watts maximum
 E L E C T R I C A L I N P U T : 120 Volts, 60 Hertz, 1 Phase
 E L E C T R I C A L O U T P U T : 2.5 mA @ 6800 VDC (Nominal)
 T E M P E R A T U R E R A T I N G : 40°F/ 4°C to 125°F/ 52°C

440657-002
 2000 cfm/ 3400m³/hr.
 .11 in. w.g. @ 2000 CFM/
 27.3 Pa @ 3400 m³/hr.
 (2) 10 Lbs./ 4.5 kg.
 79 Lbs./ 35.8 kg.
 80 watts maximum
 120 Volts, 60 Hertz, 1 Phase
 2.5 mA @ 6800 VDC (Nominal)
 40°F/ 4°C to 125°F/ 52°C

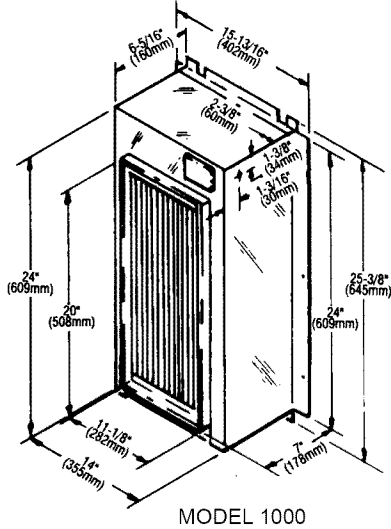

MODEL 1000

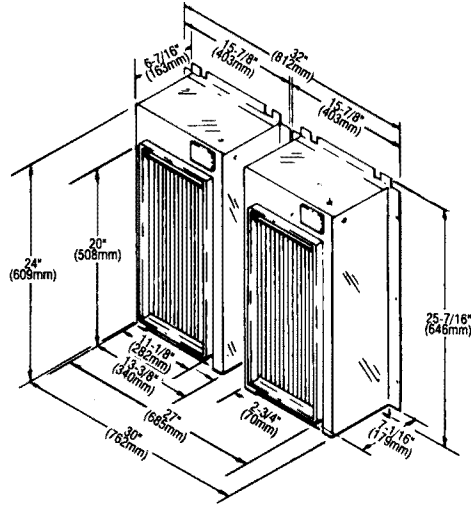

MODEL 2000

CALL O U T S

- 1) Ionizer-Collecting Cell (2) 2000 CFM
- 2) Cabinet Housing Assembly
- 3) Pre-Filter (2) 2000 CFM
- 4) Grille Assembly
- 5) Power Supply Board Assembly
- 6) On/Off Switch
- 7) Input Power LED Light (Green)
- 8) Output Power LED Light (Red)
- 9) Safety Interlock Switch
- 10) Contact Board Assembly
- 11) Transformer

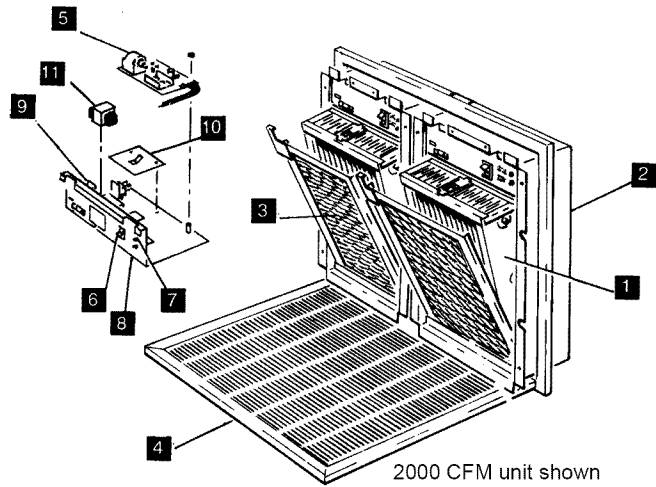

2000 CFM unit shown