

⚠ WARNING THIS SERVICE DATA SHEET IS INTENDED FOR USE BY PERSONS HAVING ELECTRICAL AND MECHANICAL TRAINING AND A LEVEL OF KNOWLEDGE OF THESE SUBJECTS GENERALLY CONSIDERED ACCEPTABLE IN THE APPLIANCE REPAIR TRADE. THE MANUFACTURER CANNOT BE RESPONSIBLE, NOR ASSUME ANY LIABILITY FOR INJURY OR DAMAGE OF ANY KIND ARISING FROM THE USE OF THIS DATA SHEET.

DISCONNECT POWER BEFORE SERVICING

IMPORTANT - RECONNECT ALL GROUNDING DEVICES. ALL PARTS OF THIS APPLIANCE CAPABLE OF CONDUCTING ELECTRICAL CURRENT ARE GROUNDED. IF GROUNDING WIRES, SCREWS, STRAPS, NUTS OR WASHERS USED TO COMPLETE A PATH TO GROUND ARE REMOVED FOR SERVICE, THEY MUST BE RETURNED TO THEIR ORIGINAL POSITION AND PROPERLY FASTENED.

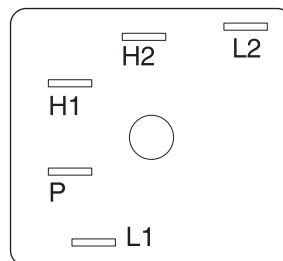

Figure 2

If the infinite switch contacts are good, and the element does not heat, check for voltage at the element receptacle. If no voltage is indicated, check for broken wiring or loose connections. If voltage is indicated, the problem is in the heating element.

Indicator Light

If the elements heat up but the indicator light does not glow, check for voltage at the indicator terminals. 240 VAC should be present at the indicator terminals. If voltage is present at the indicator terminals, replace the indicator light. If no voltage is present at the indicator terminals, check for loose connections, broken wiring, or open L1-P contact in the infinite switch.

Surface Elements

If the heating element does not heat up, check for line voltage at receptacle. Approximately 240 VAC should be indicated at the element receptacle with the infinite switch in the HI position. If no voltage is indicated at receptacle, check for loose connections, broken wiring, or a defective infinite switch. If voltage is present at the receptacle terminals, check element for continuity using procedures below.

1. Shut off power to range.
2. Remove element from receptacle.
3. Set ohmmeter to R X 10 scale and attach meter leads to element. A low OHMS reading (continuity) should be indicated, and this reading may vary slightly on each element tested. If infinite OHMS (open) is indicated, element must be replaced (see Figure 3).

Surface Elements (Infinite) Switch

The surface elements and controls provide an infinite choice of heat settings for cooking. Controls are safety type and must be pushed in before turning. All surface controls are marked on the control panel for their respective heating element. Power is supplied to the surface elements through the infinite switch contacts L1-H1 and L2-H2.

Continuity tests can be performed on the infinite switch contacts. All tests should be performed with power to the range disconnected, and wiring removed from the switch. Set an ohmmeter on R X 1K scale and check the contacts in the chart below (Figure 1). The location of the switch terminals is shown in Figure 2.

Contact	Dial Position		
	OFF	LO-MED	HI
L1 - P	○	X	X
L1 - H1	○	X	X
L2 - H2	○	X - C	X

Figure 1

NOTE: During actual surface element operation, contacts L2-H2 will cycle to maintain the correct heat setting. Contacts L1-P provide power to the surface element indicator light.

IMPORTANT
DO NOT REMOVE THIS BAG
OR DESTROY THE CONTENTS
 WIRING DIAGRAMS AND SERVICE
 INFORMATION ENCLOSED
REPLACE CONTENTS IN BAG

Bake Element

If the bake element does not heat up, check for line voltage across element terminals. Approximately 240 VAC should be indicated across terminals. If no voltage is indicated across terminals, check for broken wire between thermostat and element. Check thermostat. If voltage is present at the element, check element for continuity using procedures below.

1. Shut off power to range.
2. Remove wire leads from element terminals.
3. Set ohmmeter to R X 10 scale and attach meter leads to element. A low OHMS reading (continuity) should be indicated. If infinite OHMS (open) is indicated, element must be replaced.

Broil Element

If the broil element does not heat up, check for line voltage at element terminals. Approximately 240 VAC should be indicated at the element. If no voltage is indicated across terminals, check for broken wire between thermostat and element. Check thermostat. If voltage is present at the element, check element for continuity using procedures below.

1. Shut off power to range.
2. Remove wire leads from element terminals.
3. Set ohmmeter to R X 10 scale and attach meter leads to element. A low OHMS reading (continuity) should be indicated. If infinite OHMS (open) is indicated, element must be replaced.

Thermostat Selector Switch

The temperature control is a combination thermostat and selector switch assembly. The temperature control is performed by cycling contacts in the thermostat.

The selection of bake or broil operation is done at the control dial. The contacts C-BA are closed when a bake temperature is selected. The contacts C-BR are closed when the broil function is chosen.

Oven Indicator Light

The oven indicator light operates any time the thermostat selector switch is placed in operation. It will cycle with the operation of the cycling contacts in the thermostat (glows with contacts closed). It is a 240 VAC indicator light.

TYPICAL NON-SELF CLEAN RANGE

Schematic Diagram

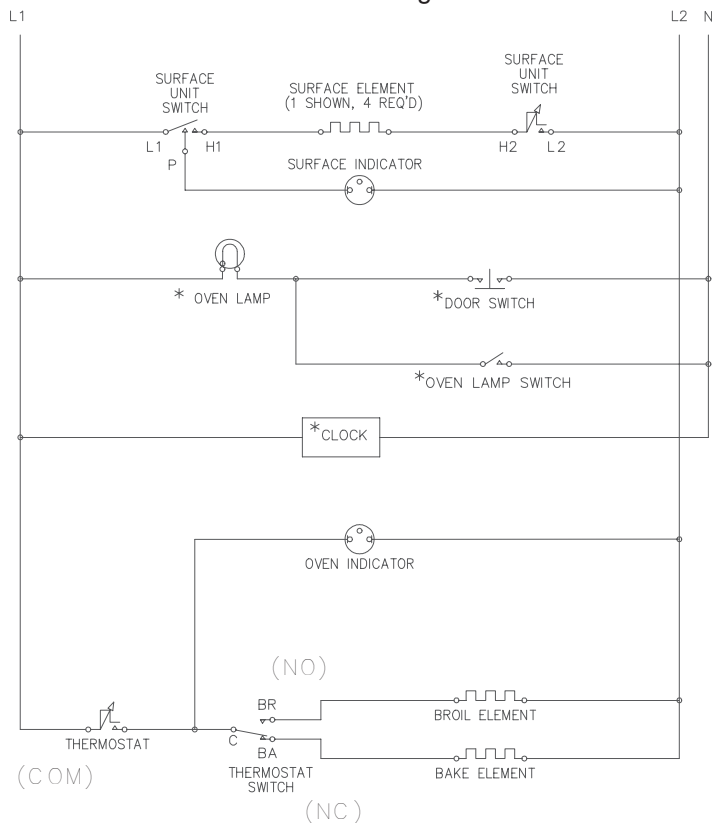

THERMOSTAT SELECTOR SWITCH		
CONTACTS	BAKE	BROIL
C-BA	X	
C-BR		X
X INDICATES CONTACTS CLOSED		

* THESE COMPONENTS MAY NOT APPEAR ON ALL MODELS.

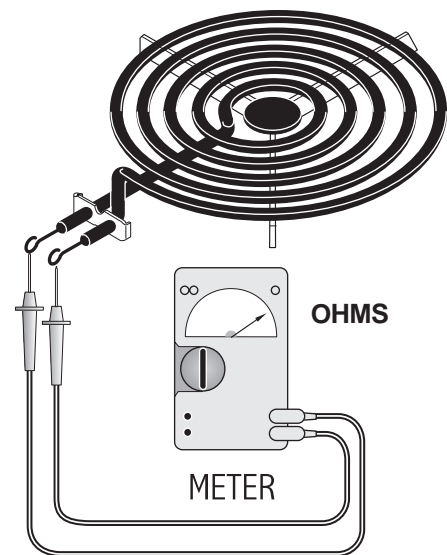

Figure 3