

use & care guide



ELECTRIC RANGE

Set-In
Model
RS600BXV

Dishwashers Clothes Dryers Freezers Refrigerator Freezers Ice Makers Dishwashers Built-In Ovens and Surface Units Ranges Microwave Ovens Trash Compact

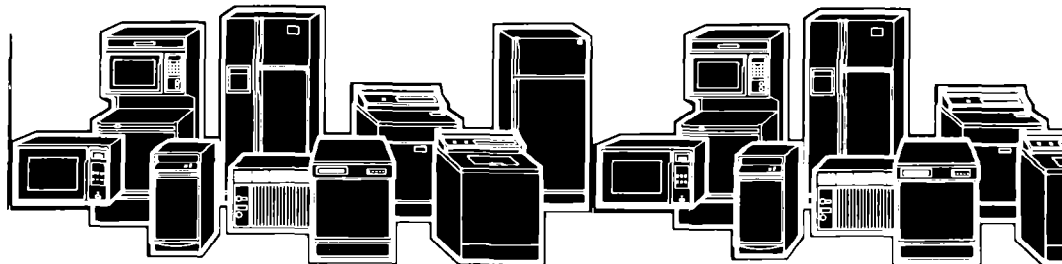

Contents

	Page		Page
BEFORE YOU USE YOUR RANGE	2	Optional Door Panel Pac	10
IMPORTANT SAFETY INSTRUCTIONS	3	CARING FOR YOUR RANGE	11
PARTS AND FEATURES	4	Control Panels and Knobs	11
USING YOUR RANGE	5	Surface Units and Reflector Bowls	12
Using the Surface Units	5	Oven Door	14
Optional Canning Kit	6	Standard Oven Cleaning	14
Using the Oven Controls	7	Cleaning Chart	15
Baking	7	Oven Light	16
Broiling	9	IF YOU NEED SERVICE OR ASSISTANCE	17
Oven Vent	10	WHIRLPOOL RANGE WARRANTY	20
Optional Rotisserie	10		

©1988 Whirlpool Corporation

Before you use your range

Read this Use & Care Guide and the Cooking Guide for important safety information.

You are personally responsible for:

- Reading and following all safety precautions in this Use & Care Guide and the Cooking Guide.
- Installing the range where it is protected from the elements, leveled in a cabinet and on a floor strong enough to support its weight.
- Properly connecting the range to electrical supply and grounding. (See Installation Instructions.)
- Making sure the range is not used by anyone unable to operate it properly.
- Properly maintaining the range.
- Using the range only for jobs expected of a home range.

See Cooking Guide for important safety and use information.

IMPORTANT SAFETY INSTRUCTIONS



WARNING: When using your range, follow basic precautions, including the following:

- 1. DO NOT** allow children to use or play with any part of the range, or leave them unattended near it. They could be burned or injured.
- 2. DO NOT** store things children might want above the range. Children could be burned or injured while climbing on it.
- 3. DO NOT** allow anyone to touch hot surface units or heating elements. Dark colored units and elements can still be hot enough to burn severely.
- 4. KEEP** children away from the range when it is on. The cooktop and oven walls, racks and door can get hot enough to cause burns.
- 5. DO NOT** use the range to heat a room. Persons in the room could be burned or injured, or a fire could start.
- 6. KEEP** pan handles turned in, but not over another surface unit to avoid burns, injury and to help prevent the utensil from being pushed off the surface units.
- 7. DO NOT** use water on grease fires. The fire will spread. Cover fire with large lid or smother with baking soda or salt.
- 8. DO NOT** wear loose or hanging garments when using the range. They could ignite if they touch a hot surface unit or heating element and you could be burned.
- 9. DO NOT** heat unopened containers. They could explode. The hot contents could burn and container particles could cause injury.
- 10.** When adding or removing food, **MAKE SURE** to open the oven door all the way to prevent burns.

• **FOR YOUR SAFETY** •

DO NOT STORE OR USE GASOLINE OR OTHER FLAMMABLE VAPORS AND LIQUIDS IN THE VICINITY OF THIS OR ANY OTHER APPLIANCE. THEY COULD IGNITE CAUSING EXPLOSION AND/OR FIRE.

– SAVE THESE INSTRUCTIONS –

Thank you for buying a Whirlpool appliance. Please complete and mail the Owner Registration Card provided with this product. Then complete the form below. Have this information ready if you need service or call with a question.

- Copy model and serial numbers from plate (behind the oven door on the oven frame) and purchase date from sales slip.
- Keep this book and sales slip together in a handy place.

Model Number

Serial Number

Purchase Date

Service Company Phone Number

Parts and features

Model RS600BXV

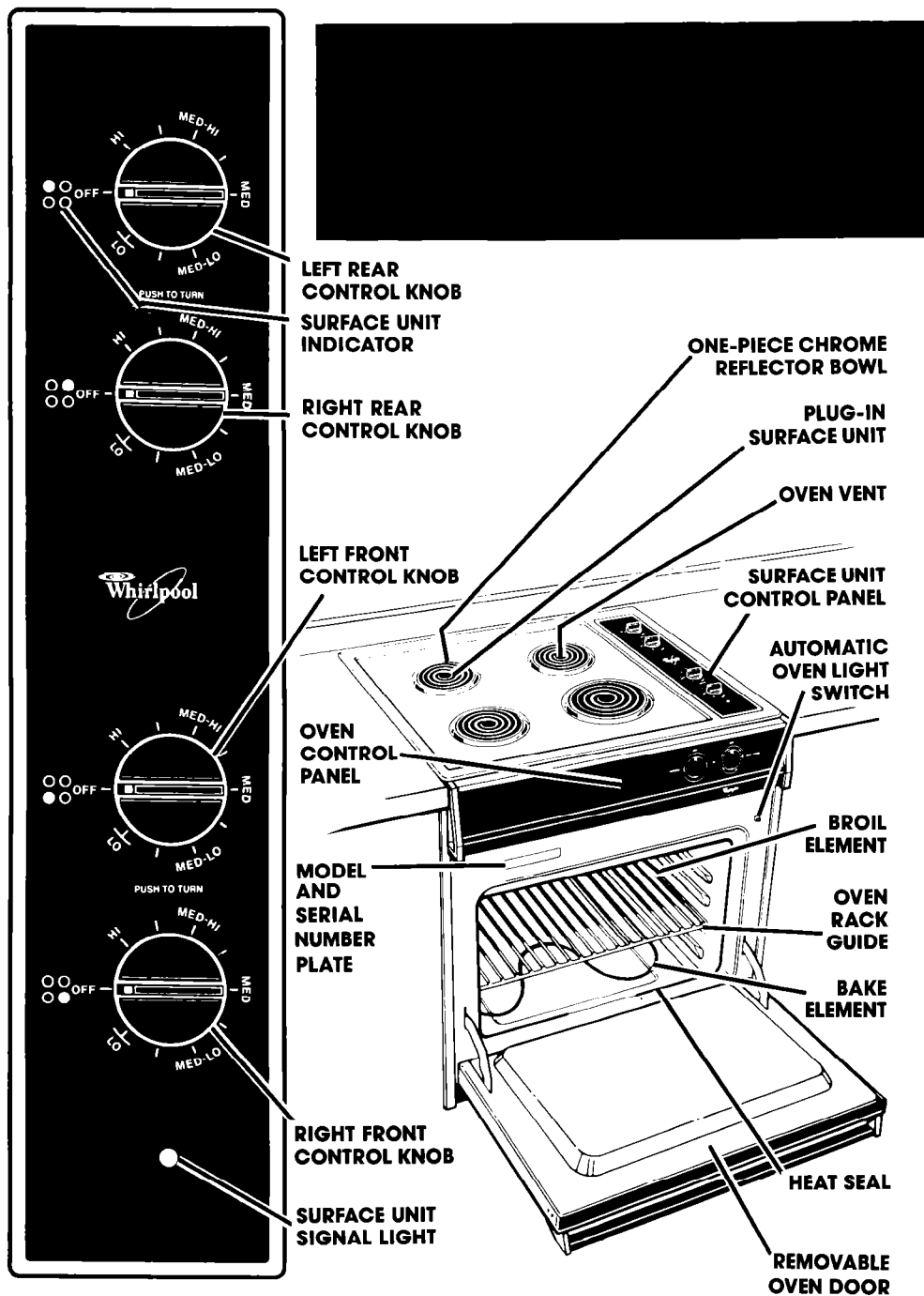

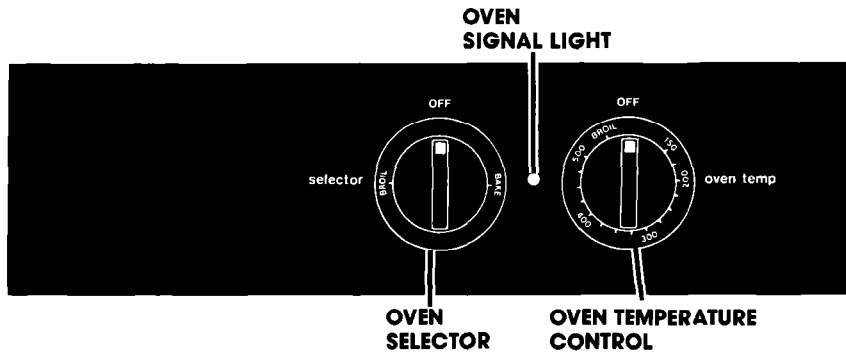

Using your range

Using the Surface Units

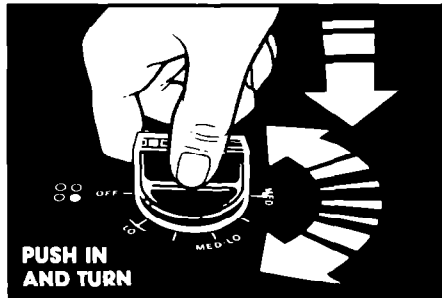

Control knobs must be pushed in before turning them to a setting. They can be set anywhere between HI and OFF.

Surface Unit Indicators

The solid dot in the surface unit indicator shows which surface unit is turned on by that knob.

Signal Light

The signal light will glow when a surface unit is on.

WARNING: Be sure the signal light is OFF when you are not cooking. Someone could be burned or a fire could start if a surface unit is accidentally left ON.

Until you get used to the settings, use the following as a guide. For best results, start cooking at the high settings; then turn the control knob down to continue cooking.

Use HI to start foods cooking; to bring liquids to a boil.

Use MED-HI to hold a rapid boil; to fry chicken or pancakes.

Use MED for gravy, puddings and icing; to cook large amounts of vegetables.

Use MED-LO to keep food cooking after starting it on a higher setting.

Use LO to keep food warm until ready to serve. Set the heat higher or lower within the LO band to keep food at the temperature you want.

CAUTION: The use of the HI setting for long periods of time can damage surface units and discolor chrome reflector bowls. Start cooking on HI and turn control down to continue cooking.

Use only flat-bottomed utensils for best cooking results and to prevent damage to the cooktop. Specialty items with rounded or ridged bottoms (woks, ridged bottom canners or tea kettles) are not recommended.



WARNING: The surface unit should never turn red during use. If it turns red, the bottom of the pan is not flat enough or is too small for the size of the surface unit. Damage to the surface unit, cooktop, wiring and/or surrounding area could result. If the pan is too small for the surface unit, you could be burned by the heat from the exposed section of the surface unit.

See the Cooking Guide for important utensil information.

Optional Canning Kit (Part No. 242905)

The large diameter of most water-bath or pressure canners combined with high heat settings for long periods of time can shorten the life of regular surface units and cause damage to the cooktop.

If you plan to use the cooktop for canning, we recommend the installation of a Canning Kit. Order the kit from your Whirlpool Dealer or Tech-Care® Service Company.

See the Cooking Guide for important canning information.

Using the Oven Controls

Baking

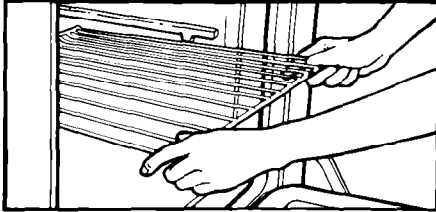

The rack should be placed so the top of the food will be centered in the oven. Always leave at least 1½ to 2 inches (4-5 cm) between the sides of the pan and the oven walls and other pans. For more information, see the Cooking Guide.

1. Position the rack properly **before** turning on the oven. To **change rack position**, lift rack at front and pull out.

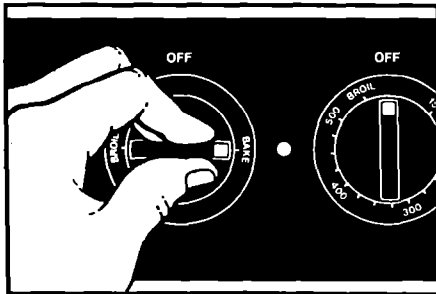

2. Set the Oven Selector to **BAKE**.

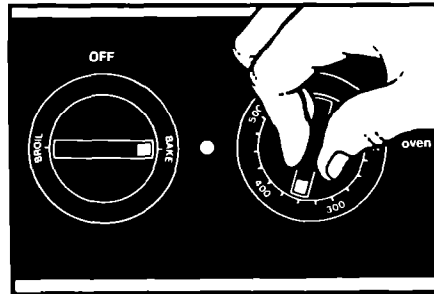

3. Set the Oven Temperature Control to the baking temperature you want. The Oven Signal Light will come on. The oven is preheated when the Oven Signal Light first goes off.

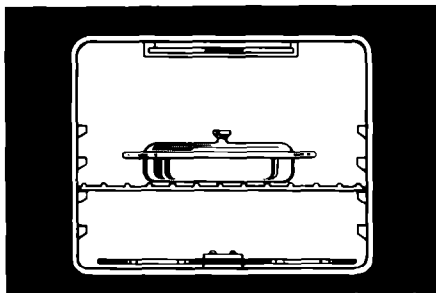

4. Put food in the oven. **NOTE: Oven rack, walls and door will be hot.** During baking, the elements will turn on and off to keep the oven temperature at the setting. The Oven Signal Light will turn on and off with the elements.

The top element helps heat during baking, but does not turn red.

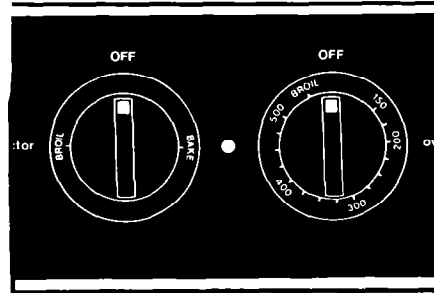

5. When baking is done, turn **both** the Oven Selector and Oven Temperature Control to **OFF**.

Adjusting the Oven Temperature Control

Does your oven seem hotter or colder than your old oven? The temperature of your old oven may have shifted gradually without you noticing the change. Your new oven is properly adjusted to provide accurate temperatures. But when comparing to your old oven, the new design may give you different results.

If after using the oven for a period of time, you are not satisfied with the temperature settings, they can be adjusted by following these steps:

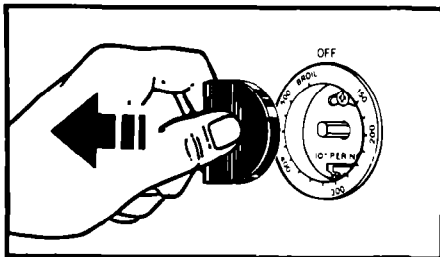

- 1. Pull the Oven Temperature Control Knob straight off.**

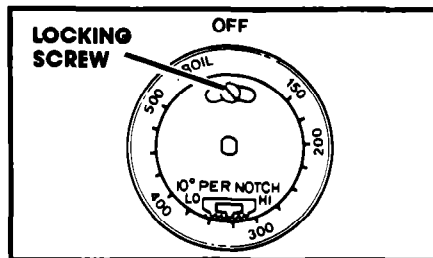

- 2. Loosen the locking screw. Note the position of the notches.**

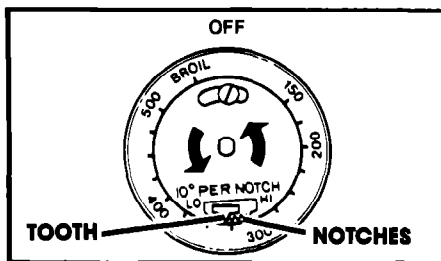

- 3. To lower the temperature, move the tooth a notch closer to LO. Each notch equals about 10°F (5°C).**

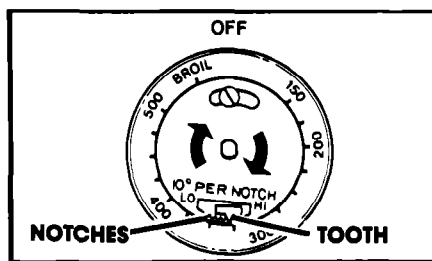

- 4. To raise the temperature, move the tooth a notch closer to HI. Each notch equals about 10°F (5°C).**

Tighten the locking screw and replace the control knob.

Broiling

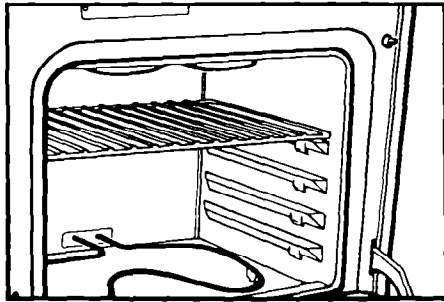

1. Position the rack before turning the oven on. See "Broil Chart" in the Cooking Guide or a reliable cookbook for recommended rack positions.

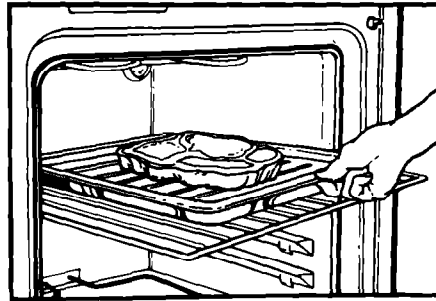

2. Put the broiler pan and food on the rack.



3. Close the door to the Broil Stop position (open about 4 inches, 10.2 cm). The door will stay open by itself.

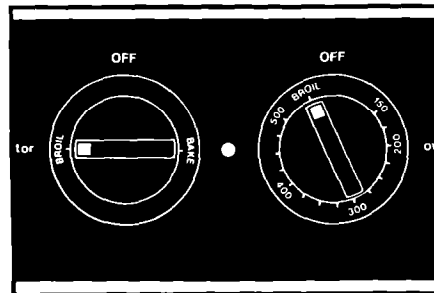

4. Set the Oven Selector and Oven Temperature Control to BROIL.

5. When broiling is done, turn **both** the Oven Selector and Oven Temperature Control to OFF.

Custom Broil

- If food is cooking too fast, turn the Oven Temperature Control **counterclockwise** until the Oven Signal Light goes off.
- If you want the food to broil slower from the start, set the Oven Temperature Control between 150° and 325°F (65.5° and 162.7°C). The lower the temperature, the slower the cooking.

The Oven Selector must be on BROIL for all broiling temperatures.

NOTE: The door must be partly open whenever the oven is set to BROIL. Leaving the door open allows the oven to maintain proper temperatures.

The Oven Vent

Hot air and moisture escape from the oven through a vent under the right rear surface unit. You can cook on the unit, or keep food warm on it while the oven is on.

CAUTION: Plastic utensils left over the vent can melt.

WARNING: If you leave a utensil on the right rear surface unit, use pot holders when moving it. Pan handles can become hot enough to burn.

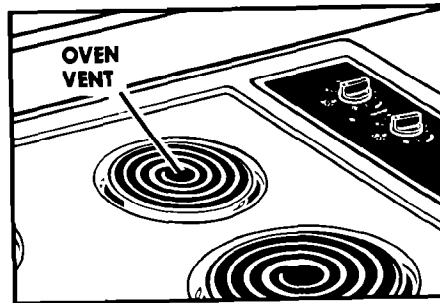

Do not block the vent. Poor baking can result.

Optional Rotisserie

If you would like a rotisserie for your oven, you can order a kit (Part No. RCK-79/261881) from your Whirlpool Dealer. The kit includes easy installation instructions.

Optional Door Panel Pac

If you would like to change the color of your oven door glass to white or almond, you can order one of these kits; White (Kit No. 814071) or Almond (Kit No. 814072) from your Whirlpool Dealer. The kits include easy installation instructions.

Caring for your range

Control Panels and Knobs



WARNING: To avoid burns and possible electric shock, first make sure all controls are OFF and the range is COOL.

1. Pull knobs straight off.
2. Use warm soapy water and a soft cloth, or spray glass cleaner, to wipe the control panels. Rinse and wipe dry.
3. Wash control knobs in warm soapy water. Rinse well and dry.
4. Push control knobs straight back on. Make sure they point to OFF.



USING YOUR RANGE • CARING FOR YOUR RANGE

Surface Units and Reflector Bowls

Removing

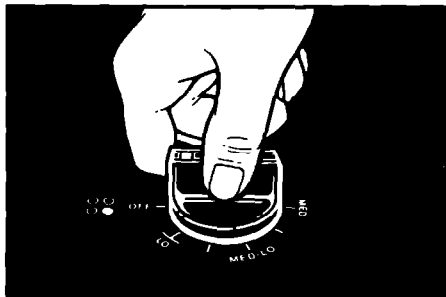

- 1.**  **WARNING:** To avoid burns and possible electric shock, be sure surface units are **OFF** and **COOL**.

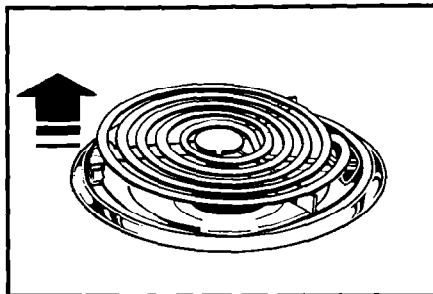

- 2.** Lift the edge of the unit, opposite the receptacle, just enough to clear the element hold down clip and the reflector bowl.

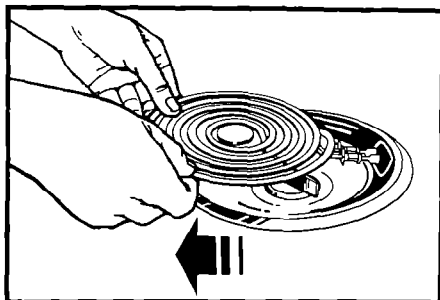

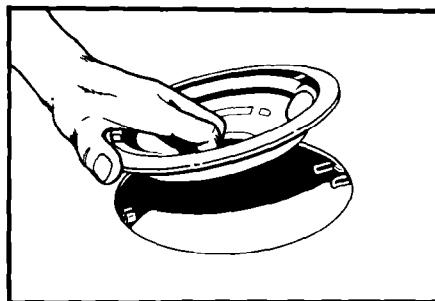

- 3.** Pull the surface unit straight away from the receptacle.

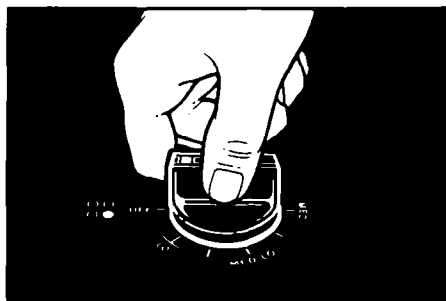

- 4.** Lift out the reflector bowl. See "Cleaning Chart" on page 15 for cleaning instructions.

Replacing



1.  **WARNING: To avoid burns and possible electric shock, be sure surface units are OFF.**

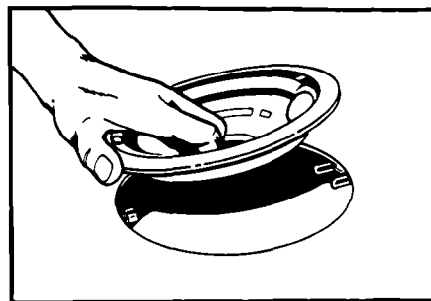

2. Line up openings in the reflector bowl with the surface unit receptacle and the element hold down clip.

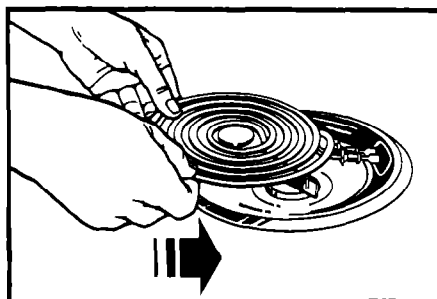

3. Hold the surface unit as level as possible with the terminal just started into the receptacle. Push the surface unit terminal into the receptacle.

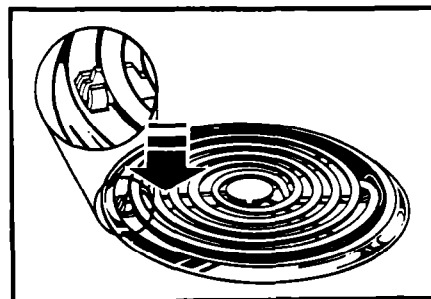

4. When terminal is pushed into the receptacle as far as it will go, push down the edge of the surface unit opposite the receptacle. The element hold down clip will keep the surface unit from moving around.

CAUTION: Reflector bowls reflect heat back to the utensils on the surface units. They also help catch spills. When they are kept clean, they reflect heat better and look new longer.

If a reflector bowl gets discolored, some of the utensils may not be flat enough, or some may be too large for the surface unit. In either case, some of the heat that's meant to go into or around a utensil goes down and heats the reflector bowl. This extra heat can discolor it. See Cooking Guide for further information.



WARNING: DO NOT LINE THE REFLECTOR BOWLS WITH FOIL. Shock or fire hazard could result.

The Oven Door

Removing the oven door will help make it easier to clean the oven.

- 1.**  **WARNING: To avoid burns, be sure the oven is OFF and COOL.**

Open the door to the first stop position.

- 2.** Hold the door at both sides and lift it **at the same angle it is in.**
- 3.** **To replace,** fit the bottom corners of the door over the ends of the hinges.

Push the door down evenly. The door will close only when it is on the hinges correctly.

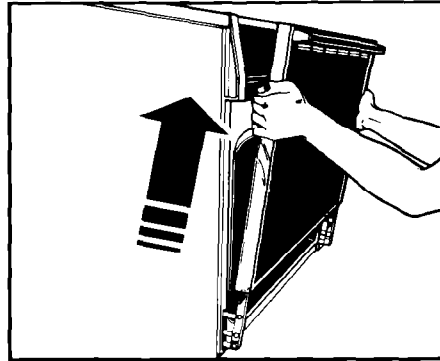

Standard Oven Cleaning

The Standard Oven has to be hand cleaned. Use warm soapy water and steel wool pads and a commercial oven cleaner. See "Cleaning Chart" for further instructions.

Do not allow commercial oven cleaner to contact the heating elements, thermostat, oven seal or exterior surfaces of the range. Damage will occur.

Using Foil

To catch sugar or starch spills from pies and casseroles, place a small shallow pan or cookie sheet on the rack directly under the cooking container.

NOTE: Do not use foil or foil liner to cover the oven floor. Poor baking results could occur.

Cleaning Chart

PART	WHAT TO USE	HOW TO CLEAN
Exterior surfaces (stainless steel finish)	Warm soapy water and a soft cloth. Plastic scrubbing pad for stubborn spots.	<ul style="list-style-type: none"> • Wipe off regularly when range is cool. • Do not allow food containing acids (such as vinegar, tomato, lemon juice or milk) to remain on surface. Acids will remove the glossy finish. • Do not use abrasive or harsh cleansers. • Make sure cooktop is COOL. • Follow directions provided with cleaner or polishing creme. <p>NOTE: For stainless steel surfaces, follow above cleaning instructions before using non-abrasive chrome cleaner or Cook Top Polishing Creme (PN 814009).</p>
Surface units	No cleaning required.	<ul style="list-style-type: none"> • Spatters or spills will burn off. • Do not immerse in water.
Chrome reflector bowls	Warm soapy water and a plastic scrubbing pad.	<ul style="list-style-type: none"> • Wash, rinse and dry well. • Clean frequently. • Do not use abrasive or harsh cleansers.
Control knobs	Warm soapy water and a soft cloth.	<ul style="list-style-type: none"> • Wash, rinse and dry well. • Do not soak.
Control panel	Warm soapy water or spray glass cleaner.	<ul style="list-style-type: none"> • Wash, rinse and dry well. • Follow directions provided with the cleaner.
Broiler pan and grid	Warm soapy water and a soapy steel wool pad.	<ul style="list-style-type: none"> • Clean after each use. • Wash, rinse and dry well.
Oven rack	Warm soapy water or soapy steel wool pads.	<ul style="list-style-type: none"> • Wash, rinse and dry. Use soapy steel wool pads for stubborn areas.
Oven door glass	Spray glass cleaner or warm soapy water and a plastic scrubbing pad.	<ul style="list-style-type: none"> • Make sure oven is cool. • Follow directions provided with the cleaner. • Wash, rinse and dry well.
Standard oven	Warm soapy water or soapy steel wool pads. Commercial oven cleaners.	<ul style="list-style-type: none"> • Remove door for easier access. • Place newspaper on floor to protect floor surface. • Follow directions provided with the oven cleaner. • Rinse well with clear water. • Use in well ventilated room. • Do not allow commercial oven cleaners to contact the heating elements, oven seal or exterior surfaces of the range. Damage will occur.

The Oven Light

The oven light will come on when you open the oven door.

To Replace:

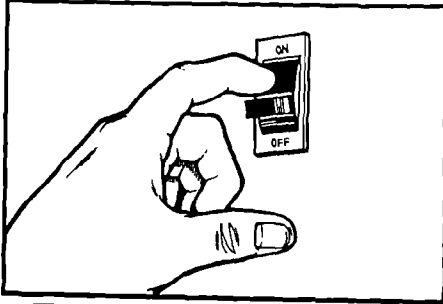

1.  **WARNING: To avoid possible shock hazard, turn off the electric power at the main power supply.**

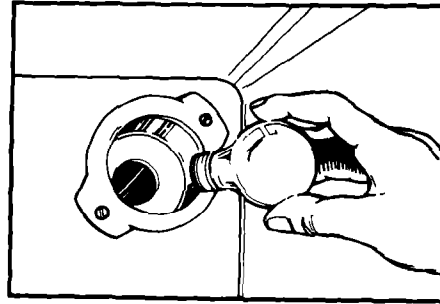

2. Remove the light bulb from its socket. Replace with a 40-watt appliance bulb. Turn the power back on at the main power supply.

If you need service or assistance, we suggest you follow these five steps:

1. Before calling for assistance...

Performance problems often result from little things you can find and fix without tools of any kind.

If nothing operates:

- Is the range correctly wired into a live circuit with the proper voltage? (See Installation Instructions.)
- Have you checked your home's main fuses or circuit breaker box?

If the oven will not operate:

- Is the Oven Selector turned to a setting (BAKE or BROIL)?
- Is the Oven Temperature Control turned to a temperature setting?

If surface units will not operate:

- Have you checked your home's main fuses or circuit breaker box?
- Are surface units plugged in all the way?
- Do the control knobs turn?

If surface unit control knob(s) will not turn:

- Did you push in before trying to turn?

If cooking results aren't what you expected:

- Is the range level?
- Are you using pans recommended in the Cooking Guide?
- If baking, have you allowed 1½ to 2 inches (4-5 cm) on all sides of the pans for air circulation?
- Have you preheated the oven as the recipe calls for?
- Are the pans the size called for in the recipe?
- Are you following a tested recipe from a reliable source?
- Do the cooking utensils have smooth, flat bottoms and fit the surface unit being used?

See the Cooking Guide for more information on cooking problems and how to solve them.

2. If you need assistance*...

Call Whirlpool COOL-LINE® service assistance telephone number. Dial free from anywhere in the U.S.:
1-800-253-1301

and talk with one of our trained consultants. The consultants can instruct you in how to obtain satisfactory operation from your appliance or, if service is necessary, recommend a qualified service company in your area.

3. If you need service*...



Whirlpool has a nationwide network of franchised TECH-CARE® Service Companies.

TECH-CARE service technicians

are trained to fulfill the product warranty and provide after-warranty service, anywhere in the United States. To locate TECH-CARE service in your area, call our COOL-LINE® service assistance telephone number (see Step 2) or look in your telephone directory Yellow Pages under:

APPLIANCES - HOUSEHOLD - MAJOR - SERVICE & REPAIR	OR	ELECTRICAL APPLIANCES - MAJOR - REPAIRING & PARTS
WHIRLPOOL APPLIANCES FRANCHISED TECH-CARE SERVICE		WHIRLPOOL APPLIANCES FRANCHISED TECH-CARE SERVICE
SERVICE COMPANIES		SERVICE COMPANIES
XYZ SERVICE CO 123 Maple 999-9999		XYZ SERVICE CO 123 Maple 999-9999
OR		
WASHING MACHINES, DRYERS & IRONERS - SERVICING		
WHIRLPOOL APPLIANCES FRANCHISED TECH-CARE SERVICE		
SERVICE COMPANIES		
XYZ SERVICE CO 123 Maple 999-9999		

4. If you have a problem*...

Call our COOL-LINE service assistance telephone number (see Step 2) and talk with one of our consultants, or if you prefer, write to:

Mr. Donald Skinner
Director of Customer Relations
Whirlpool Corporation
2000 M-63
Benton Harbor, MI 49022

5. If you need FSP® replacement parts*...

FSP is a registered trademark of Whirlpool Corporation for quality parts. Look for this symbol of quality whenever you need a replacement part for your Whirlpool appliance. FSP replacement parts will fit right and work right, because they are made to the same exacting specifications used to build every new Whirlpool appliance.

To locate FSP replacement parts in your area, refer to Step 3 above or call the Whirlpool COOL-LINE service assistance number in Step 2.

*If you must call or write, please provide: model number, serial number, date of purchase, and a complete description of the problem. This information is needed in order to better respond to your request for assistance.

WHIRLPOOL® RANGE PRODUCT WARRANTY

ER001

LENGTH OF WARRANTY	WHIRLPOOL WILL PAY FOR
FULL ONE-YEAR WARRANTY From Date of Purchase	FSP® replacement parts and repair labor to correct defects in materials or workmanship. Service must be provided by a franchised TECH-CARE® service company.
WHIRLPOOL WILL NOT PAY FOR	
<p>A. Service calls to:</p> <ol style="list-style-type: none"> 1. Correct the installation of the range product. 2. Instruct you how to use the range product. 3. Replace house fuses or correct house wiring or plumbing. 4. Replace owner accessible light bulbs. <p>B. Repairs when range product is used in other than normal, single-family household use.</p> <p>C. Pick up and delivery. This product is designed to be repaired in the home.</p> <p>D. Damage to range product caused by accident, misuse, fire, flood, acts of God or use of products not approved by Whirlpool.</p>	

WHIRLPOOL CORPORATION SHALL NOT BE LIABLE FOR INCIDENTAL OR CONSEQUENTIAL DAMAGES. Some states do not allow the exclusion or limitation of incidental or consequential damages so this limitation or exclusion may not apply to you. This warranty gives you specific legal rights, and you may also have other rights which vary from state to state.

Outside the United States, a different warranty may apply. For details, please contact your franchised Whirlpool distributor or military exchange.



Part No. 3148321
©1988 Whirlpool Corporation

Printed in U.S.A.

Makers. Dishwashers. Built-In Ovens and Surface Units. Ranges. Microwave Ovens. Trash Compactors. Room Air Conditioners. Dehumidifiers. Automatic W.

