

# Use & Care Manual

Top Mount

# Refrigerator

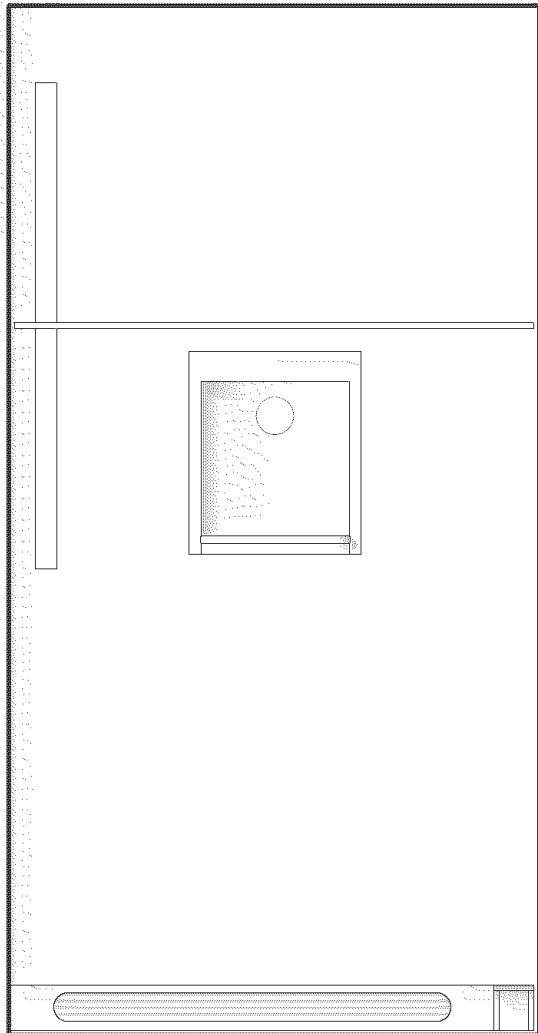

Español ..... 21

|  |         |   |
|--|---------|---|
| <b>Welcome</b> .....   | 2       |    |
| <b>Safety Instructions</b> .....   | 3       |    |
| <b>Installation</b> -- Includes Connecting<br>Optional Ice Maker To Water Supply ..... | 4 - 5   |    |
| <b>Door Removal</b> .....  | 6       |    |
| <b>Features at a Glance</b> .....  | 7       |    |
| <b>Temperature Controls</b> .....  | 8       |   |
| <b>Looking Inside</b> .....  | 9 - 11  |  |
| <b>Water Dispenser<br/>&amp; Ice Service</b> .....                                     | 12 - 14 |  |
| <b>Food Storage<br/>&amp; Energy Saving Tips</b> .....                                 | 15      |  |
| <b>Normal Operating Sounds</b> ..  | 16      |  |
| <b>Care &amp; Cleaning</b> .....   | 17- 18  |  |
| <b>Warranty</b> .....  | 19      |  |
| <b>Before You Call</b> .....   | 20      |  |



# Welcome & Congratulations

Congratulations on your purchase of a new refrigerator! We here at **Electrolux Home Products, Inc.** are very proud of our product and we are completely committed to providing you with the best service possible. Your satisfaction is our #1 priority.

Please read this Use & Care Manual very carefully. It contains valuable information on how to properly maintain your new refrigerator.

We know you'll enjoy your new refrigerator and **Thank You** for choosing our product. We hope you consider us for future purchases.

## PLEASE READ AND SAVE THESE INSTRUCTIONS

This Use & Care Manual provides specific operating instructions for your model. Use your refrigerator only as instructed in this manual. These instructions are not meant to cover every possible condition and situation that may occur. Common sense and caution must be practiced when installing, operating and maintaining any appliance.

**Please record your model and serial numbers below for future reference. This information is found on your serial plate located inside the refrigerator compartment.**

**NOTE:** Use only soap and water to clean serial plate.

Model Number: \_\_\_\_\_

Serial Number: \_\_\_\_\_

Purchase Date: \_\_\_\_\_

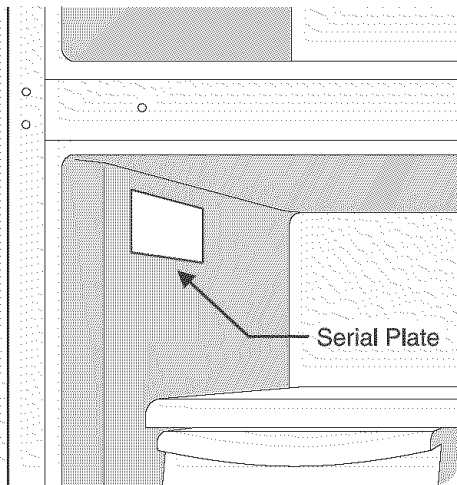

Please complete and mail in the **Product Registration Card** included with your refrigerator.

## Questions?

**1-800-944-9044**

(United States)

**1-800-668-4606**

(Canada)

## Extend Your Warranty Protection With An *Extended Service Contract*

**CALL 1-800-944-9044  
To Enjoy These Benefits:**

- **Total freedom from repair bills** so unexpected repairs won't upset your budget.
- **Fast, convenient toll-free service** is just a phone call away.
- **Top-quality repairs** by factory-trained experts.
- **Quick access to genuine replacement parts** so you can rest assured your refrigerator is repaired with the proper components.

Please attach sales receipt here for future reference.



## Important Safety Instructions

**⚠ WARNING** Please Read All Instructions Before Using This Refrigerator.

### FOR YOUR SAFETY

- Do not store or use gasoline, or other flammable liquids in the vicinity of this or any other appliance. Read product labels for warnings regarding flammability and other hazards.
- Do not operate the refrigerator in the presence of explosive fumes.
- Avoid contact with any moving parts of automatic ice maker.
- Remove all staples from the carton. Staples can cause severe cuts, and also destroy finishes if they come in contact with other appliances or furniture.

### CHILD SAFETY

Destroy or recycle the carton, plastic bags, and any exterior wrapping material immediately after the refrigerator is unpacked. Children should **NEVER** use these items to play. Cartons covered with rugs, bedspreads, plastic sheets or stretch wrap may become airtight chambers, and can quickly cause suffocation.

**⚠ WARNING** These Guidelines Must Be Followed To Ensure That Safety Mechanisms In This Refrigerator Will Operate Properly.

### ELECTRICAL INFORMATION

- **The refrigerator must be plugged into its own dedicated 115 Volt, 60 Hz., AC only electric outlet.** The power cord of the appliance is equipped with a three-prong grounding plug for your protection against electrical shock hazards. It must be plugged directly into a properly grounded three-prong receptacle. The receptacle must be installed in accordance with local codes and ordinances. Consult a qualified electrician. **Do not use an extension cord or adapter plug.**
- If the power cord is damaged, it should be replaced by the manufacturer, service technician or a qualified person to prevent any risk.
- Never unplug the refrigerator by pulling on the power cord. Always grip the plug firmly, and pull straight out from the receptacle to prevent damaging power cord.
- Unplug the refrigerator before cleaning and before replacing a light bulb to avoid electrical shock.
- Performance may be affected if the voltage varies by 10% or more. Operating the refrigerator with insufficient power can damage the compressor. Such damage is not covered under your warranty.
- Do not plug the unit into an outlet controlled by a wall switch or pull cord to prevent the refrigerator from being turned off accidentally.
- Avoid connecting refrigerator to a Ground Fault Interruptor (GFI) circuit.

### PROPER DISPOSAL OF YOUR REFRIGERATOR OR FREEZER

#### *Risk of child entrapment*

Child entrapment and suffocation are not problems of the past. Junked or abandoned refrigerators or freezers are still dangerous – even if they will sit for “just a few days.” If you are getting rid of your old refrigerator or freezer, please follow the instructions below to help prevent accidents.

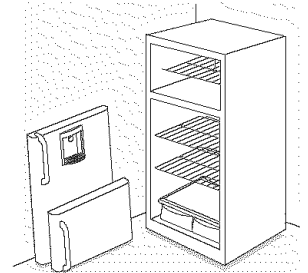

#### **Before you throw away your old refrigerator/ freezer:**

- Remove doors.
- Leave shelves in place so children may not easily climb inside.
- Have refrigerant removed by a qualified service technician.

**IMPORTANT:** Turning the refrigerator temperature control to “0” turns off the compressor and prevents your refrigerator from cooling, but does not disconnect the power to the light bulbs and other electrical components. To turn off power to your refrigerator you must unplug the power cord from the wall outlet.

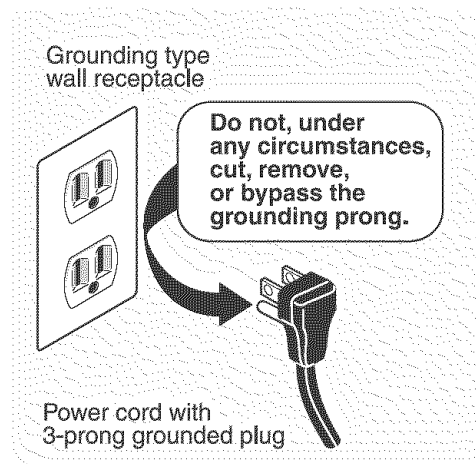

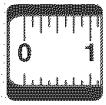

# Installation

This Use & Care Manual provides specific operating instructions for your model. Use the refrigerator only as instructed in this Use & Care Manual. **Before starting the refrigerator, follow these important first steps.**

## LOCATION

- Choose a place that is near a grounded electrical outlet. **Do Not** use an extension cord or an adapter plug.
- If possible, place the refrigerator out of direct sunlight and away from the range, dishwasher or other heat sources.
- The refrigerator must be installed on a floor that is level and strong enough to support a fully loaded refrigerator.
- Consider water supply availability for models equipped with an automatic ice maker or water dispenser.

## INSTALLATION

**CAUTION** Do Not install the refrigerator where the temperature will drop below 55°F (13°C) or rise above 110°F (43°C). The compressor will not be able to maintain proper temperatures inside the refrigerator.

**CAUTION** Do Not block the toe grille on the lower front of your refrigerator. Sufficient air circulation is essential for the proper operation of your refrigerator.

### Installation Clearances

- Allow the following clearances for ease of installation, proper air circulation, and plumbing and electrical connections:
  - Sides & Top ----- 3/8"
  - Back ----- 1"

## DOOR OPENING

**NOTE:** If your refrigerator is placed with the door hinge side against a wall, you may have to allow additional space so the door can be opened wider.

Your refrigerator should be positioned to allow easy access to a counter when removing food.

## LEVELING

All four corners of your refrigerator must rest firmly on a solid floor. Your refrigerator is equipped with adjustable front rollers to help level your unit.

### To Level Your Refrigerator:

1. Remove toe grille.

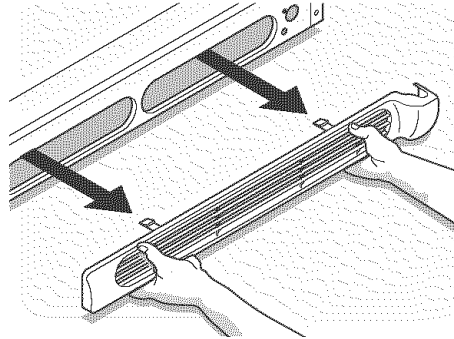

2. Use flat-blade screwdriver or 3/8" socket wrench to adjust front rollers.

**NOTE:** Raise the front of the refrigerator enough so the doors close freely when opened halfway. The refrigerator should slope 1/4" to 1/2" from front-to-back. Then level the refrigerator from side to side.

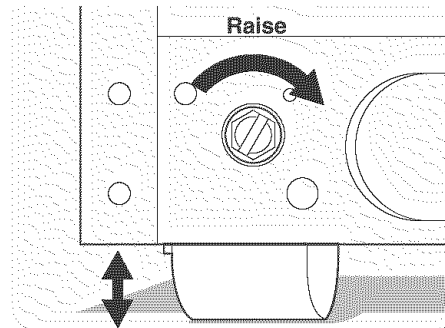

## WATER DISPENSER DRIP TRAY

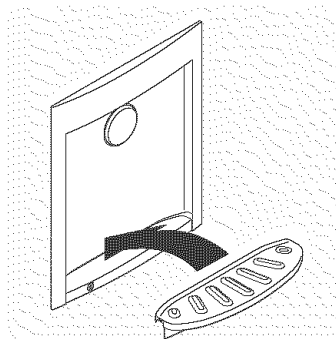

The drip tray for your refrigerator's water dispenser comes from the factory detached. Its removal also allows easy cleaning. To install the drip tray, fit it into the bottom of the dispenser bay and snap into place.

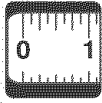

## Installation - Connecting To Water Supply

**⚠ WARNING** To avoid electric shock, which can cause death or severe personal injury, disconnect the refrigerator from electrical power before connecting a water supply line to the refrigerator.

**⚠ CAUTION** To Avoid Property Damage:

- Copper tubing is recommended for the water supply line. Water supply tubing made of ¼" plastic is not recommended since it greatly increases the potential for water leaks. Manufacturer will not be responsible for any damage if plastic tubing is used for supply line.
- DO NOT install water supply tubing in areas where temperatures fall below freezing.
- Chemicals from a malfunctioning softener can damage the ice maker. If the ice maker is connected to soft water, ensure that the softener is maintained and working properly.

**IMPORTANT:** Ensure that your water supply line connections comply with all local plumbing codes.

### Before Installing The Water Supply Line, You Will Need

- **Basic Tools:** adjustable wrench, flat-blade screwdriver, and Phillips™ screwdriver
- Access to a household cold water line with water pressure between 30 and 100 psi.
- A water supply line made of ¼ inch (6.4 mm) OD, copper tubing. To determine the length of copper tubing needed, you will need to measure the distance from the ice maker inlet valve at the back of the refrigerator to your cold water pipe. Then add approximately 7 feet (2.1 meters), so the refrigerator can be moved out for cleaning (as shown).
- A shutoff valve to connect the water supply line to your household water system. **DO NOT** use a self-piercing type shutoff valve.
- A compression nut and ferrule (sleeve) for connecting the water supply line to the ice maker inlet valve.

**NOTE:** Water line kit number 5303917950, available from your appliance dealer at additional cost, contains 25 feet (7.6 meters) of ¼ inch OD copper tubing, a saddle type shutoff valve (nonpiercing), (2) ¼ inch brass compression nuts, (2) ferrules/sleeves, and instructions for installing a water supply line.

### To Connect Water Supply Line To Inlet Valve

1. Disconnect refrigerator from electric power source.
2. Place end of water supply line into sink or bucket. Turn ON water supply and flush supply line until water is clear. Turn OFF water supply at shut off valve.
3. Unscrew plastic cap from water valve inlet and discard cap.
4. Slide brass compression nut, then ferrule (sleeve) onto water supply line, as shown.
5. Push water supply line into water valve inlet as far as it will go (¼ inch). Slide ferrule(sleeve) into valve inlet and finger tighten compression nut onto valve. Tighten another half turn with a wrench; **DO NOT** over tighten.
6. With steel clamp and screw, secure water supply line to rear panel of refrigerator as shown.
7. Coil excess water supply line (about 2½ turns) behind refrigerator as shown and arrange coils so they do not vibrate or wear against any other surface.
8. Turn ON water supply at shutoff valve and tighten any connections that leak.
9. Reconnect refrigerator to electrical power source.
10. To turn ice maker on, lower wire signal arm (see ice maker front cover for ON/OFF position of arm).

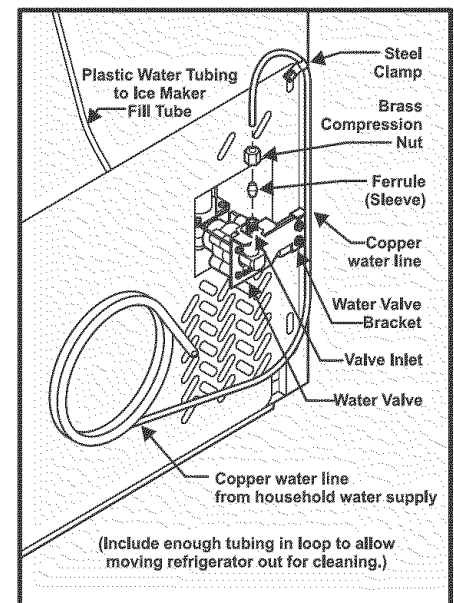

**IMPORTANT:** It takes approximately 24 hours for the ice maker to begin producing ice. Air in new plumbing lines may cause ice maker to cycle two or three times before making a full tray of ice. New plumbing may cause ice to be discolored or have poor flavor. Discard ice made during the first 24 hours.



# Door Removal Instructions

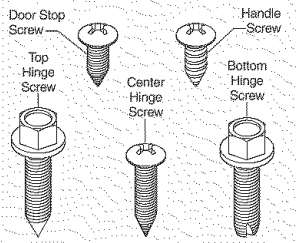

## Tools Necessary:

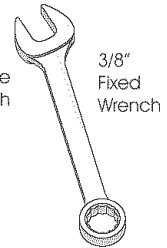
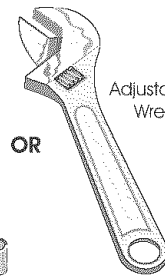
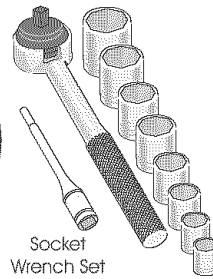
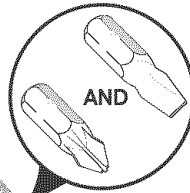
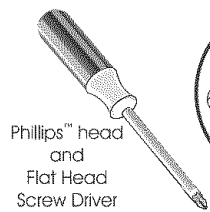

## DOOR REMOVAL INSTRUCTIONS:

If your refrigerator will not fit through an entrance area, you can reduce its size by removing the doors. Check first by measuring the entrance.

**IMPORTANT:** Before you begin, turn the refrigerator temperature control to "0" and remove the electrical power cord from the wall outlet. Remove food from door shelves.

1. Disconnect electrical supply.
2. Remove toe grille (see page 4 to learn how).

### To remove freezer door:

1. Remove top hinge cover and screws.
2. Trace around the hinge with a soft lead pencil. This makes reinstallation easier.
3. Remove top hinge and lift door off bottom hinge pin.
4. Reverse this procedure to reinstall freezer door.

### To remove refrigerator door:

1. Place wood block under door to support its weight.
2. Unfasten the multi-wire cable bracket by removing its screw from the cabinet.
3. Detach the multi-wire cable connector located below the door. Place your thumbs on flat sides of each connector, grasp firmly, and bend both ends back and forth while pulling apart.

**NOTE:** You may need to insert a flat screwdriver between the connector ends to release the locking tab (see illustration).

4. Detach the water tube from the connector located below the door. The connector releases when you press its outer sleeve inward.

**NOTE:** If refrigerator has been used, have a container ready to catch excess water from tube.

5. Remove the bottom hinge screws and hinge, holding the door as its weight rests on the wood block. Lay the door on its side to avoid damage to cable and tube.
6. Remove the center hinge screws and hinge. Ensure plastic washer stays on hinge pin.
7. Reverse this procedure to reinstall refrigerator door. When both doors are reinstalled, connect water line by inserting tube and pushing until mark touches face of fitting. Connect cable, replace toe grille, and plug in electrical power cord.

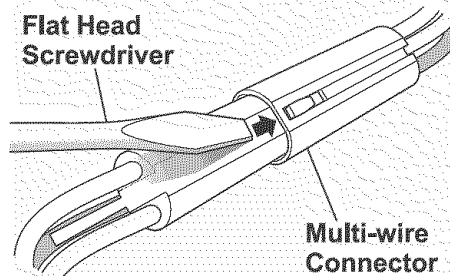
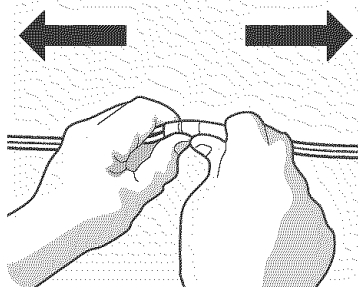
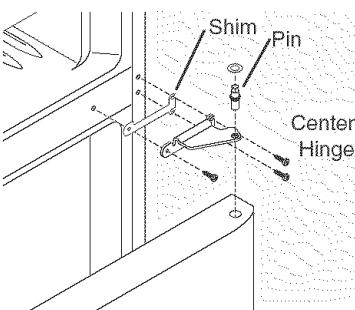
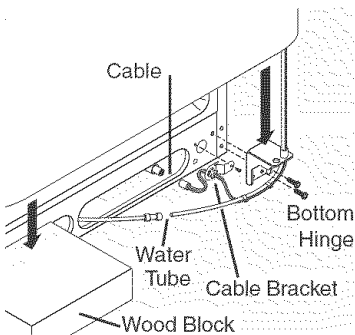
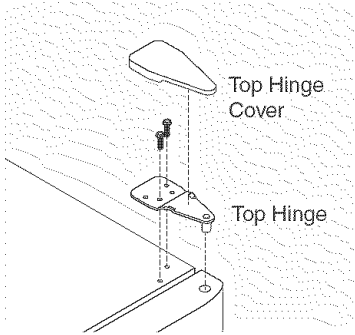

### TO DISCONNECT

1. Press outer ring against face of fitting
2. Pull to remove tube

### TO CONNECT

- Insert tube and push until mark touches face of fitting



## Features At A Glance

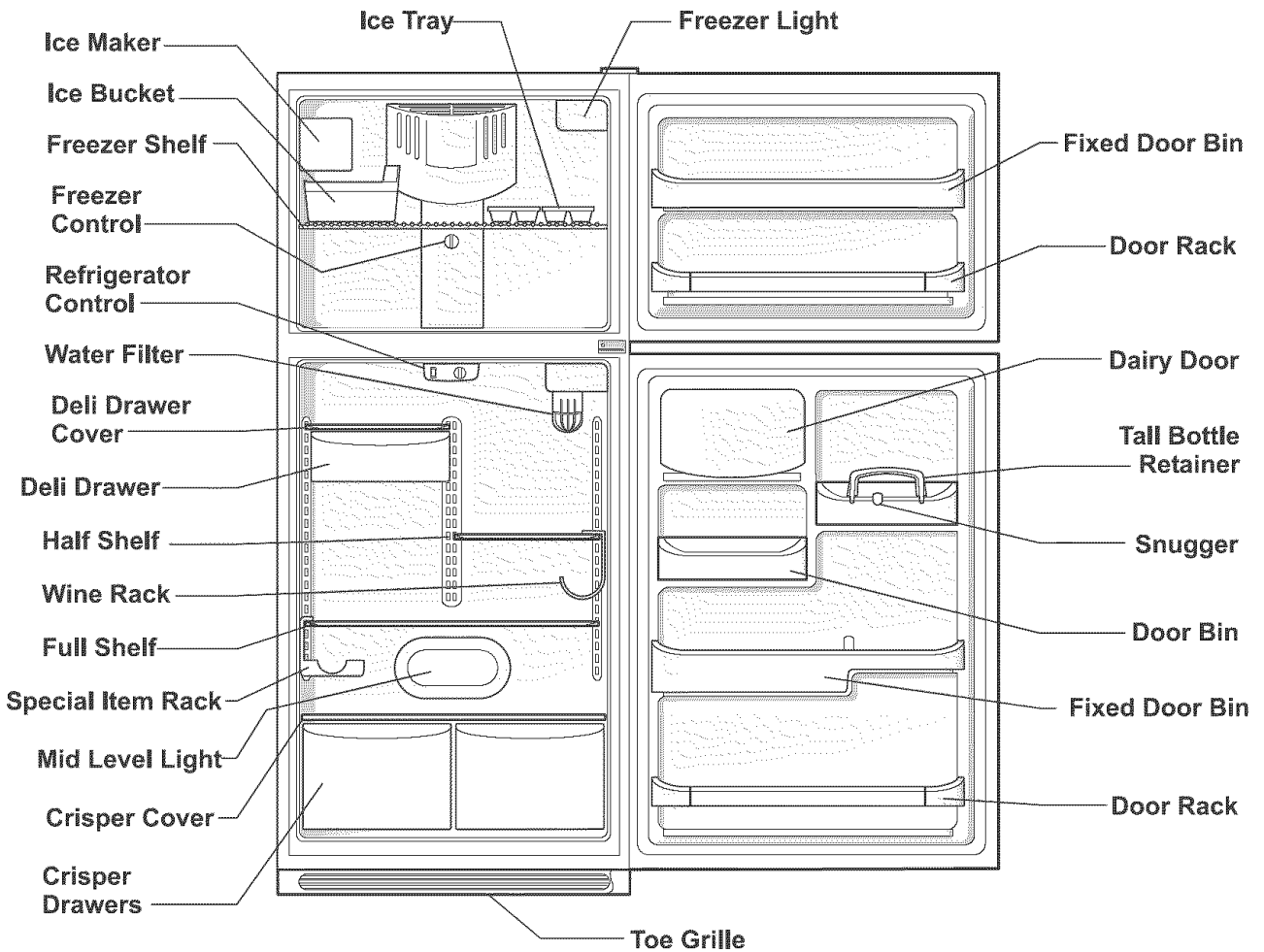

*Features may vary according to model*



# Temperature Controls

## COOL DOWN PERIOD

To ensure safe food storage, allow the refrigerator to operate with the doors closed for at least 8 to 12 hours before loading it with food.

## REFRIGERATOR & FREEZER CONTROLS

**NOTE:** When changing control settings, wait 24 hours before making additional adjustments.

## TEMPERATURE ADJUSTMENT

**NOTE:** When first turning refrigerator on, move refrigerator and freezer controls to ▼ which is the recommended initial setting. After 24 hours, adjust the controls as needed.

- **Adjust temperature gradually: move the knob in small increments, allowing the temperature to stabilize.**
- For colder temperatures, turn the knob towards **Colder**.
- For warmer temperatures, turn the knob towards **Cold**.

Turning the refrigerator control will change temperatures in both compartments. For example, if the refrigerator control is turned to a colder setting, the freezer control may have to be adjusted to a warmer setting. Turning the freezer control will change only the freezer temperature.

To maintain temperatures, a fan circulates air in the refrigerator and freezer compartments. For good circulation, do not block cold air vents with food items.

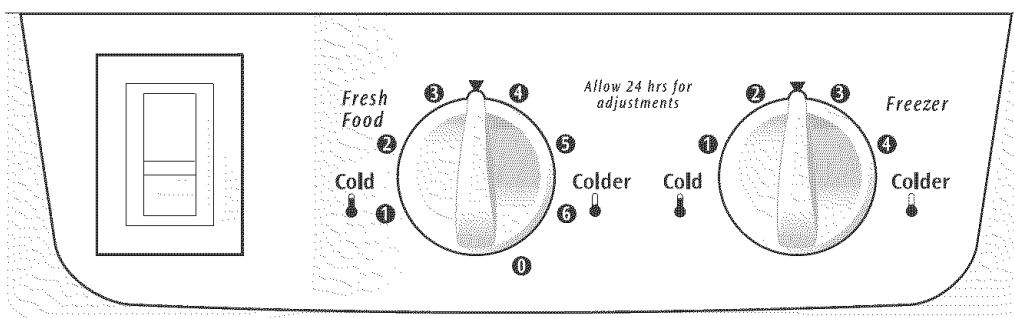
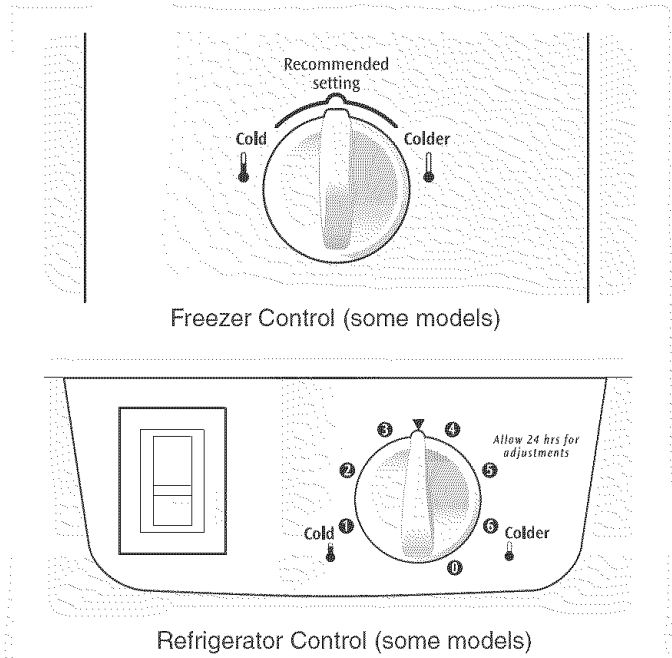

**\* IMPORTANT:** Turning the refrigerator temperature control to "0" turns off the compressor, but does not disconnect the power to the light bulb and other electrical components. To turn off power to your refrigerator, you must unplug the power cord from the wall outlet.

| TEMPERATURE ADJUSTMENT GUIDE            |  |
|---|--|
| If Refrigerator compartment Is Too Warm | Turn Refrigerator Control Slightly Towards <b>Colder</b> . |
| If Refrigerator compartment Is Too Cold | Turn Refrigerator Control Slightly Towards <b>Cold</b> .   |
| If Freezer compartment Is Too Warm      | Turn Freezer Control Slightly Towards <b>Colder</b> .      |
| If Freezer compartment Is Too Cold      | Turn Freezer Control Slightly Towards <b>Cold</b> .        |
| * To Turn Refrigerator Off              | Turn Refrigerator Control To <b>0</b> .                    |



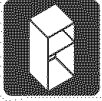

## Looking Inside

**CAUTION** To avoid personal injury or property damage, handle tempered glass shelves carefully. Shelves may break suddenly if nicked, scratched, or exposed to sudden temperature change.

### SHELF ADJUSTMENT

Refrigerator shelves are easily adjusted to suit individual needs. Before adjusting the shelves, remove all food.

#### To adjust sliding shelves:

- 1 Remove shelf by pulling forward to stop position.
- 2 Lift front edge up and pull out.

Replace the shelf on any pair of rails by reversing this procedure.

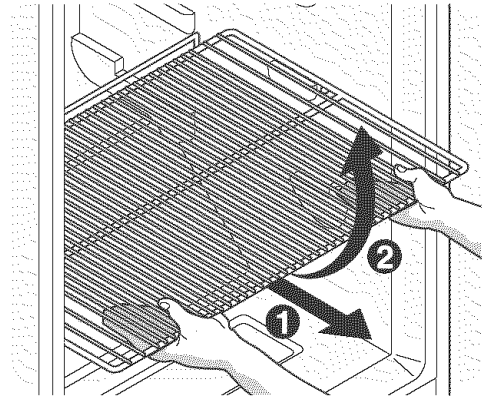

Sliding Wire Shelf

#### To adjust cantilever shelves:

**NOTE:** Cantilever shelves are supported at the back of the refrigerator. Cantilever shelves are available in either glass or wire.

- 1 Lift front edge up.
- 2 Pull shelf out.

Replace the shelf by inserting the hooks at rear of the shelf into the wall bracket. Lower the shelf into the desired slots and lock into position.

*SpillSafe™* glass shelves (some models) catch and hold accidental spills. In some models, the *SpillSafe™* shelves slide out for easy access to food and for fast cleaning. The shelves slide out independently of the cantilever brackets. Just pull the front of the shelf forward. The shelf can be extended as far as the stopper will allow but it is **not** removable from the cantilever bracket.

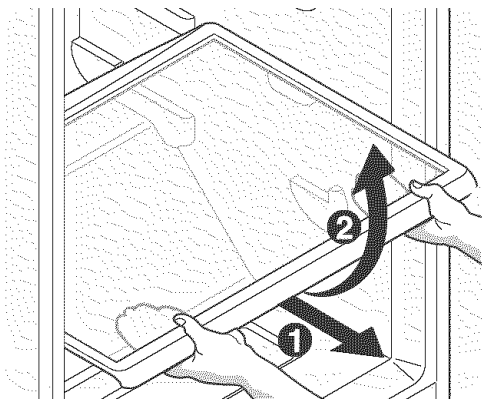

Sliding Glass Shelf

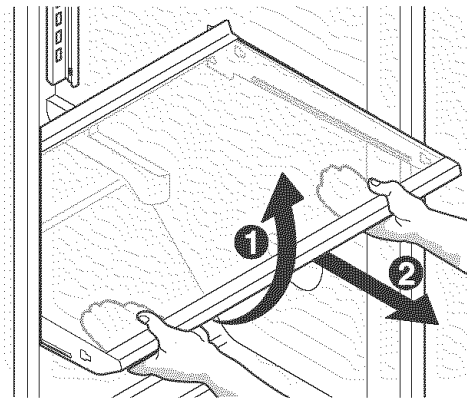

Full Width Cantilever Glass Shelf

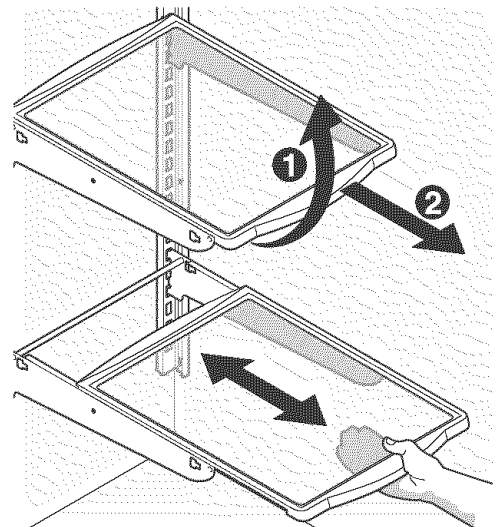

Cantilever Glass Shelf - Fixed and Sliding



## Looking Inside (continued)

### DOOR STORAGE

Door bins, shelves, and racks are provided for convenient storage of jars, bottles, and cans. Frequently used items can be quickly selected.

Some models have door racks or bins that can accommodate gallon-sized plastic drink containers and economy-sized jars and containers. Some racks are adjustable for maximum storage capacity.

The dairy compartment, which is warmer than the general food storage section, is intended for short term storage of cheese, spreads, or butter.

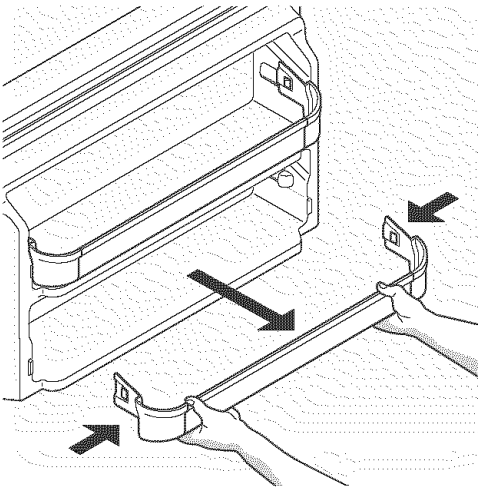

Door Rack

### ADJUSTABLE DOOR BINS

Some models have adjustable door bins that can be moved to suit individual needs.

*To move door bins*

1. Lift bin straight up.
2. Remove bin.
3. Place bin in desired position.
4. Lower bin onto supports until locked in place.

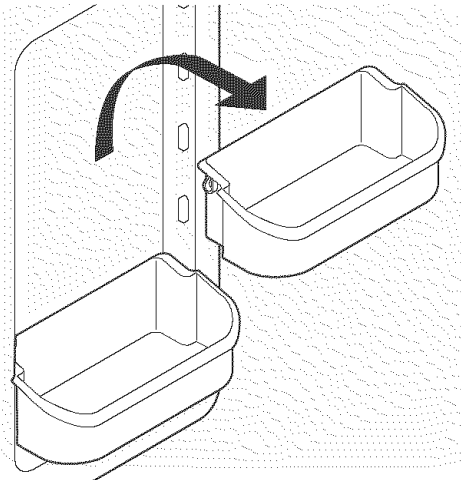

Adjustable Door Bin

### TALL BOTTLE RETAINER (SOME MODELS)

The Tall Bottle Retainer keeps tall containers in the bin from falling forward when opening or closing the refrigerator door. To install, hold the retainer at the top, and slide it over the outside wall of the bin, as shown in the diagram. The Tall Bottle Retainer works best with a Bin Snugger.

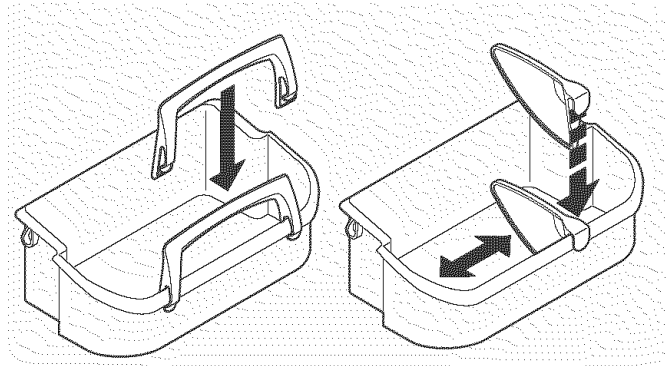

Tall Bottle Retainer (left) and Bin Snugger (right)

### SPECIAL ITEM RACK (SOME MODELS)

The innovative design of the Special Item Rack allows you to store a six-pack of 12 ounce drink cans, a bottle of wine, a two-liter soft drink bottle, or a carton of eggs. The Special Item Rack mounts on the left side of your refrigerator. To install, just slide the Special Item Rack onto any shelf as shown in the drawing.

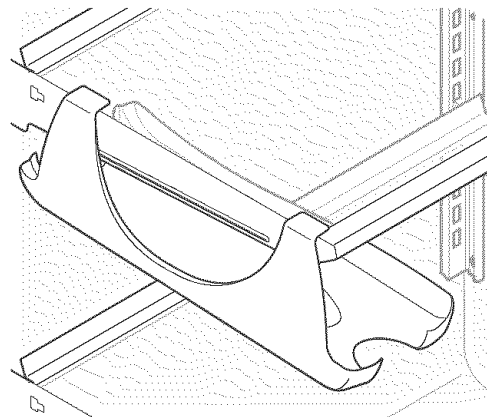

Special Item Rack



## Looking Inside - (continued)

### CRISPERS (SOME MODELS)

The crispers, located under the bottom refrigerator shelf, are designed for storing fruits, vegetables, and other fresh produce. Wash items in water and remove excess water before placing them in the crispers. Items with strong odors or high moisture content should be wrapped before storing.

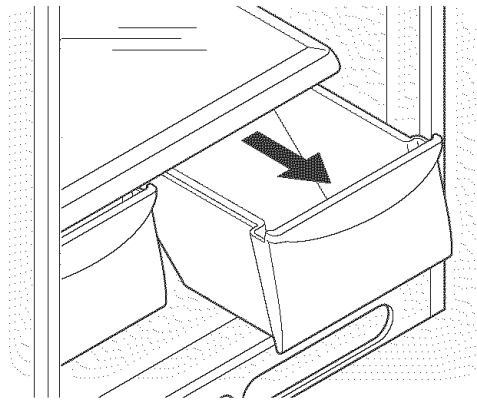

Crisper Drawer

### HUMIDITY CONTROL (SOME MODELS)

The Humidity Control, present on some models with crisper drawers, allows you to adjust the humidity within the crisper. This can extend the life of fresh vegetables that keep best in high humidity.

**NOTE:** Leafy vegetables keep best when stored with the Humidity Control set on **High Humidity**, or in a drawer without a Humidity Control. This keeps incoming air to a minimum and maintains maximum moisture content.

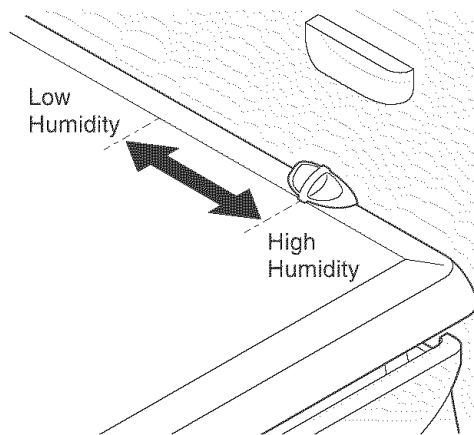

Crisper Humidity Control

### DELI DRAWER (SOME MODELS)

Some models are equipped with a Deli Drawer for storage of luncheon meats, spreads, cheeses, and other deli items.

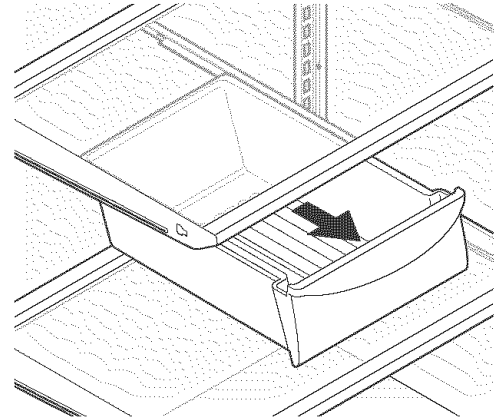

Deli Drawer

### WINE RACK (SOME MODELS)

The Wine Rack stores bottles of wine, or single two-liter plastic bottles of juice or soda pop. To install, slide the Wine Rack onto the shelf with the curve facing in. To remove, slide the Wine Rack out. Install on either side of shelf.

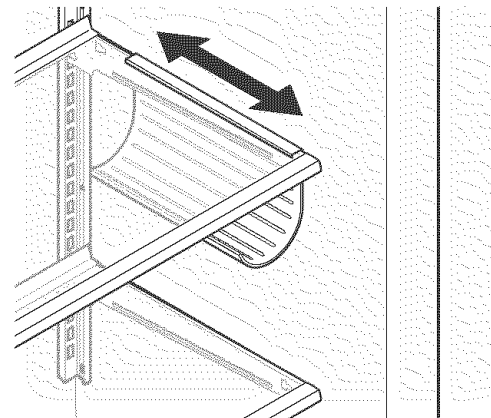

Wine Rack



# Water Dispenser & Ice Service

## WATER DISPENSER

Your refrigerator includes an automatic water dispenser on the front of the refrigerator door. The dispenser is designed to accommodate containers up to 7½ inches high.

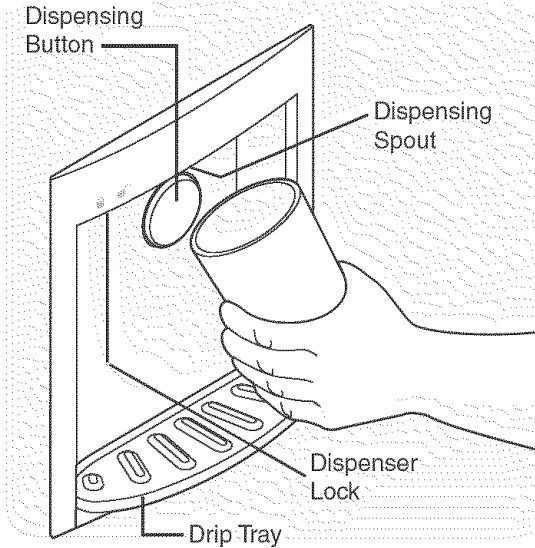

Water Dispenser

### Dispensing Water

To operate the water dispenser, press a drinking glass against the dispensing button. Hold the glass as far up as possible, ensuring that the water dispensing spout is inside the lip of the glass.

To stop dispensing water, pull the glass away from the dispensing button. For colder water, first add ice to your drinking glass.

### Drip Tray

The drip tray located at the base of the dispenser catches small spills and allows them to evaporate. This tray is removable for easy cleaning.

**NOTE:** Please do not pour excess water or ice into the drip tray. It does not have a drain.

### Dispenser Lock

The water dispenser includes a switch that allows you to disable the water dispenser. You can use this lock to prevent accidental spills, such as those caused by children pressing the dispensing button without a glass. The switch is located below the locked/unlocked symbols on the dispenser face plate.

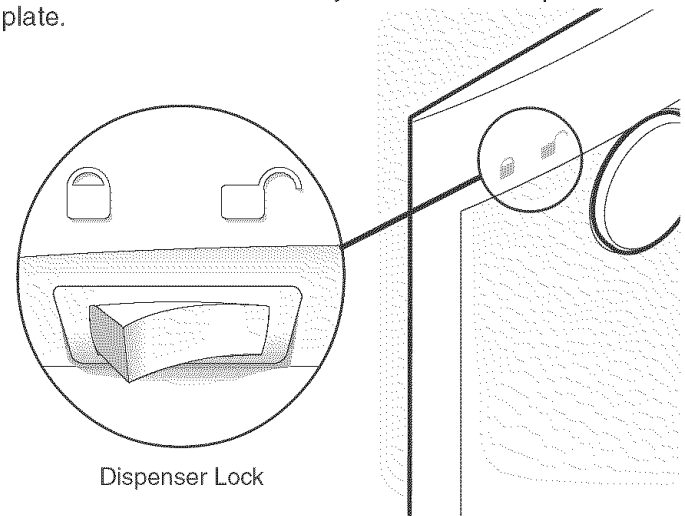

### How the Water Dispenser Works

The water tank, located inside the refrigerator door, automatically fills as water is dispensed. For proper dispenser operation, the recommended supply water pressure should fall between 20 psi and 100 psi.

**CAUTION** Water pressure must not exceed 100 lbs. Excessive pressure may cause water filter to malfunction.

After the refrigerator is connected to the water supply, fill the water tank by drawing one glass of water. **It may take about 1½ minutes** after activating the dispenser button before water begins to fill this first glass. Continue flushing the system for 3 minutes to rid the tank and plumbing connections of any impurities.



## Water Dispenser & Ice Service (continued)

### ICE MAKER

If your refrigerator has an automatic ice maker, it will provide a sufficient supply of ice for normal use. During the initial startup of your refrigerator, however, no ice will be produced during the first 24 hours of operation. Automatic ice makers are also optional accessories that may be installed in most models at any time. Call your local dealer for information.

The ice maker produces 2 to 5 pounds of ice every 24 hours depending on usage conditions. Ice is produced at a rate of 8 cubes every 80 to 160 minutes.

#### Turning Your Ice Maker On

After the plumbing connections have been completed, the water supply valve must be opened. Place the ice container under the ice maker, pushing it as far back as possible. Lower the wire signal arm to its “down” or ON position. New plumbing connections may cause the first production of ice cubes to be discolored or have an odd flavor. These first cubes should be discarded until the cubes produced are free of discoloration and taste.

#### Turning Your Ice Maker Off

To stop the ice maker, lift the wire signal arm until it clicks and locks in the “up” or OFF position. The ice maker also turns off automatically when the ice container is full. If your model has an adjustable freezer shelf, place the shelf in the lower position, so that the wire signal arm will hit the ice when the container is full.

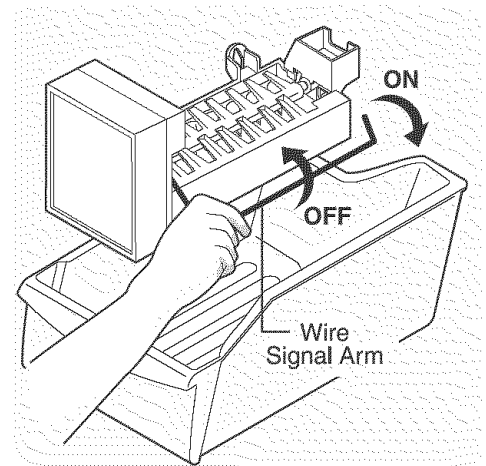

Ice Maker

**IMPORTANT:** Your ice maker is shipped with the wire signal arm in the ON position. To ensure proper function of your ice maker, hook up water supply immediately or turn ice maker OFF by lifting the wire signal arm until it clicks and locks in the UP position.



**CAUTION** Chemicals from a malfunctioning softener can damage the ice maker. If the ice maker is connected to soft water, ensure that the softener is maintained and working properly.

### Ice Maker Tips

- Ice cubes stored too long may develop an odd flavor. Empty the ice container and ensure that the wire signal arm is in its “down” or ON position. The ice maker will then produce more ice.
- Occasionally shake the ice container to keep ice separated.
- Keep the wire signal arm in its “up” or OFF position until the refrigerator is connected to the water supply or whenever the water supply is turned off.
- The following sounds are normal when the ice maker is operating:
  - Motor running
  - Ice loosening from tray
  - Ice dropping into ice container
  - Running water
  - Water valve opening or closing

**NOTE:** For more information on these operations, see the *Normal Operating Sounds and Sights* section.



**CAUTION** Do Not place the ice container in your dishwasher.

- Wash the ice container in warm water with mild detergent. Rinse well and dry.
- Stop the ice maker when cleaning the freezer and during vacations.
- If the ice maker will be turned off for a long period of time, turn the water supply valve to the closed position.



## Water Dispenser & Ice Service (continued)

### PureSource™ \* ICE AND WATER FILTER (some models)

**NOTE:** If you purchased a refrigerator with a PureSource™ \* Ice and Water filter, please read the following use and care information. This ice and water filter system filters water to your ice maker and water dispenser. It is located in the upper right back corner of the fresh food compartment.

#### System Startup:

Water supply does not need to be turned off, however, do not use ice and water dispenser while installing filter. The filter cartridge has already been installed in the filter housing at the factory. Refer to the *How The Water Dispenser Works* section to properly fill the system with water.

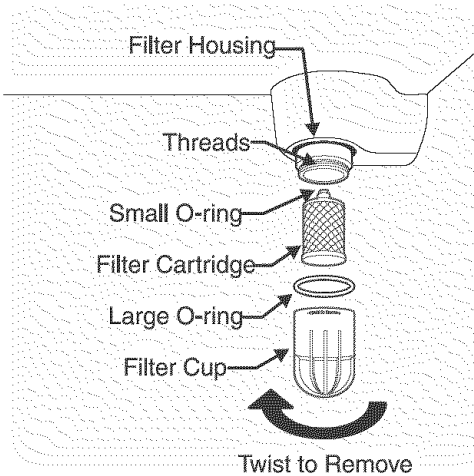

#### Changing the Filter:

Water conditions vary throughout the world, but changing the water filter every 6 - 9 months normally will ensure the highest possible water quality. If the filter has been in a refrigerator that has not been in use for awhile (during moving for example), change the filter before reinstalling the refrigerator. The dispenser system will also operate without filtration (with filter cartridge removed).

#### To change filter:

It is not necessary to turn the water supply off to change the filter.

1. Set ice maker wire signal arm to the OFF (up) position (See illustration on page 13). Turn dispenser lock to the locked position.
2. Hold filter cup firmly, and unscrew towards left (Some water could leak out as you remove cup. This is normal.). Filter cartridge should come down with cup. If cartridge remains in housing, pull down gently, while twisting filter back and forth.
3. Rinse out cup under running water.
4. The large o-ring that seals the filter system sets in the o-ring groove down inside the cup. Should the o-ring fall out during filter cartridge replacement, simply place it back in the groove prior to screwing the cup back in place. If the o-ring becomes damaged, you will need to order one from the *Consumer Assistance Center*.
5. Discard old filter cartridge.
6. Remove new filter cartridge from packaging and place in cup. The end with the small o-ring should be up, out of the cup.
7. Screw cup, with filter, back onto housing. **Do Not Use Wrench To Reinstall Cup.** Filter cartridge will self-align as cup is tightened. Be sure cup is completely tightened with **PureSource™** logo facing outward. **Do Not Tighten Past Stop.**
8. Set ice maker wire signal arm to the ON (down) position.
9. Check for leaks. Open refrigerator door. Wipe any water droplets from the filter cup. Fill a glass with water. If there is a leak, unscrew filter cup, and reinsert the filter cartridge. Check placement of large O-ring. Reinstall filter cup, making certain it is tightened completely.
10. To condition filter system and purge air from water line, fill a glass with water. Continue flushing the system for approximately 3 minutes to assure that the purest water possible is stored in the water tank.

Order new filter cartridges through the dealer where you bought the refrigerator, contact the *Customer Care Center* at 1-800-944-9044, or go to our web site at [www.frigidaire.com](http://www.frigidaire.com). It might be good to order some filter cartridges when you first install your refrigerator. Be sure to ask for the RG-100 PureSource™\* replacement cartridge.



The PureSource™ \* NGRG-2000 Ice and Water Filter System with the RG-100 cartridge is tested and certified by NSF International, the

nationally recognized and respected, not for profit, certification organization for public health safety. The PureSource™\* system is tested and certified to ANSI/NSF Standard 42. See performance data sheet for specifications. This system should not be used on water that is microbiologically unsafe or with water of unknown quality unless the water has been adequately disinfected before or after traveling through the filtration system.

- Rated Capacity - 400 gallons
- Rated service flow - .5 GPM
- Maximum Rated Pressure - 100 PSI
- Maximum Operating Temp. - 100° F

#### Filter Replacement Reminder Stickers

There is a set of Reminder Stickers included in the envelope that the Use & Care Guide came in. Choose a dated sticker that indicates 6 - 9 months (depending on your water quality and usage) from the date of installation. Place the sticker on the front of the filter cup to remind you when it is time to change the filter.

\* White Westinghouse uses the name CrystalClear instead of PureSource, but they are the same filter



## Food Storage & Energy Saving Ideas

### FOOD STORAGE IDEAS

#### *Fresh Food Storage*

- The fresh food compartment should be kept between 34° F and 40° F with an optimum temperature of 37° F.
- Avoid overcrowding the refrigerator shelves. This reduces the circulation of air around the food and results in uneven cooling.

#### *Fruits and Vegetables*

- Storage in the crisper drawers traps moisture to help preserve the fruit and vegetable quality for longer time periods.

#### *Meat*

- Raw meat and poultry should be wrapped securely so leakage and contamination of other foods or surfaces does not occur.

#### *Frozen Food Storage*

- The freezer compartment should be kept at 0° F or lower.
- A freezer operates most efficiently when it is at least 2/3 full.

#### *Packaging Foods for Freezing*

- To minimize dehydration and quality deterioration, use aluminum foil, freezer wrap, freezer bags or airtight containers. Force as much air out of the packages as possible and seal them tightly. Trapped air can cause food to dry out, change color, and develop an off-flavor (freezer burn).
- Wrap fresh meats and poultry with suitable freezer wrap prior to freezing.
- Do not refreeze meat that has completely thawed.

#### *Loading the Freezer*

- Avoid adding too much warm food to the freezer at one time. This overloads the freezer, slows the rate of freezing, and can raise the temperature of frozen foods.
- Leave a space between the packages, so cold air can circulate freely, allowing food to freeze as quickly as possible.
- Avoid storing hard-to-freeze foods such as ice cream and orange juice on the freezer door shelves. These foods are best stored in the freezer interior where the temperature varies less.



### ENERGY SAVING IDEAS

- Locate the refrigerator in the coolest part of the room, out of direct sunlight, and away from heating ducts or registers. Do not place the refrigerator next to heat-producing appliances such as a range, oven, or dishwasher. If this is not possible, a section of cabinetry or an added layer of insulation between the two appliances will help the refrigerator operate more efficiently.
- Level the refrigerator so that the doors close tightly.
- Refer to this Use & Care Manual for the suggested temperature control settings.
- Do not overcrowd the refrigerator or block cold air vents. Doing so causes the refrigerator to run longer and use more energy.
- Cover foods and wipe containers dry before placing them in the refrigerator. This cuts down on moisture build-up inside the unit.
- Organize the refrigerator to reduce door openings. Remove as many items as needed at one time and close the door as soon as possible.



## Normal Operating Sounds & Sights

### UNDERSTANDING THE SOUNDS YOU MAY HEAR

Your new high-efficiency refrigerator may make unfamiliar sounds. These are all normal sounds and soon will become familiar to you. They also indicate your refrigerator is operating as designed. Hard surfaces, such as vinyl or wood floors, walls, and kitchen cabinets may make sounds more noticeable. Listed below are descriptions of some of the most common sounds you may hear, and what is causing them.

**NOTE:** Rigid foam insulation is very energy efficient, but is not a sound insulator.

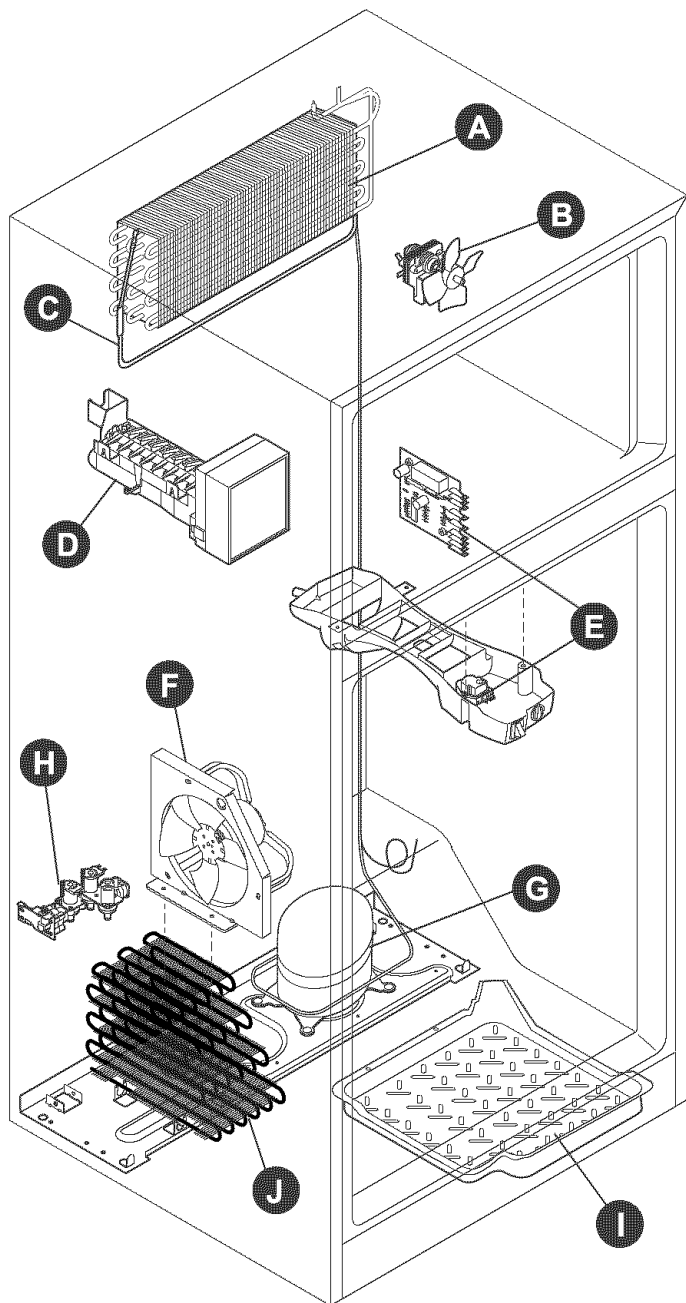

#### A. *Evaporator*

The flow of refrigerant through the evaporator may create a boiling or gurgling sound.

#### B. *Evaporator Fan*

You may hear air being forced through the refrigerator by the evaporator fan.

#### C. *Defrost Heater*

During defrost cycles, water dripping onto the defrost heater may cause a hissing or sizzling sound. After defrosting, a popping sound may occur.

**IMPORTANT:** During the automatic defrost cycle, you may notice a red glow in the vents on the back wall of your freezer compartment. This is normal during the defrost cycle.

#### D. *Automatic Ice Maker*

If your refrigerator is equipped with an automatic ice maker, you will hear ice cubes falling into the ice bin.

#### E. *Cold Control & Defrost Timer or Automatic Defrost Control*

These parts can produce a snapping or clicking sound when turning the refrigerator on and off. The timer also produces sounds similar to an electric clock.

#### F. *Condenser Fan*

If condenser coils are located underneath your refrigerator as shown in the drawing at the left, you have a condenser fan. You may hear air being forced through the condenser by the condenser fan.

#### G. *Compressor*

Modern, high-efficiency compressors operate much faster than older models. The compressor may have a high-pitched hum or pulsating sound.

#### H. *Water Valve*

If your refrigerator is equipped with an automatic ice maker, you will hear a buzzing sound as the water valve opens to fill the ice maker during each cycle.

#### I. *Drain Pan (Nonremovable)*

You may hear water running into the drain pan during the defrost cycle.

#### J. *Condenser*

May create minimal sounds from forced air.





## Care & Cleaning

Keep your refrigerator and freezer clean to prevent odor build-up. Wipe up any spills immediately and clean both sections at least twice a year. **Never** use any type of scouring pads, brushes, abrasive cleaners or strong alkaline solutions on any surface. **Do not** wash any removable parts in a dishwasher. **Always unplug the electrical power cord from the wall outlet before cleaning.**

### CAUTION

- When moving the refrigerator, pull straight out. Do not shift the refrigerator from side to side as this may tear or gouge the floor covering. If the refrigerator has an automatic ice maker, be careful not to move the refrigerator beyond the plumbing connections.
- Damp objects stick to cold metal surfaces. Do not touch refrigerated surfaces with wet or damp hands.
- Never use CHLORIDE to clean stainless steel.

### NOTES:

- Turning the refrigerator temperature control to "0" turns off the compressor, but does not disconnect electrical power to the light bulb or other electrical components. To turn off power to your refrigerator, you must unplug the power cord from the wall outlet.
- Do not use razor blades or other sharp instruments which can scratch the appliance surface when removing adhesive labels. Any glue left from tape or labels can be removed with a mixture of warm water and mild detergent, or, touch the glue residue with the sticky side of tape you have already removed. **Do not remove the serial plate.**

| Care & Cleaning Chart                                 |   |   |
|---|---|---|
| Part  | What To Use   | Tips and Precautions  |
| Interior/Door Liner                                   | <ul style="list-style-type: none"> <li>• Soap and water</li> <li>• Baking soda and water</li> </ul>                           | Use 2 tablespoons of baking soda in 1 quart of warm water. <b>Be sure to wring excess water out of sponge or cloth before cleaning around controls, light bulb or any electrical part.</b>  |
| Door Gaskets  | <ul style="list-style-type: none"> <li>• Soap and water</li> </ul>  | Wipe gaskets with a clean soft cloth.   |
| Drawers/Bins  | <ul style="list-style-type: none"> <li>• Soap and water</li> </ul>  | Do not wash any removable items (bins, drawers, etc.) in dishwasher.  |
| Glass Shelves   | <ul style="list-style-type: none"> <li>• Soap and water</li> <li>• Glass cleaner</li> <li>• Mild liquid sprays</li> </ul>     | Allow glass to warm to room temperature before immersing in warm water.   |
| Toe Grille  | <ul style="list-style-type: none"> <li>• Soap and water</li> <li>• Mild liquid sprays</li> <li>• Vacuum attachment</li> </ul> | Vacuum dust from front of toe grille. Remove toe grille (See illustration on page 4). Vacuum backside and wipe with sudsy cloth or sponge. Rinse and dry.   |
| Exterior and Handles                                  | <ul style="list-style-type: none"> <li>• Soap and water</li> <li>• Non Abrasive Glass Cleaner</li> </ul>                      | Do not use commercial household cleaners, ammonia, or alcohol to clean handles. Use a soft cloth to clean smooth handles. <b>Do Not use a dry cloth to clean smooth doors.</b>  |
| Exterior and Handles<br>(Stainless Steel Models Only) | <ul style="list-style-type: none"> <li>• Soap and water</li> <li>• Ammonia</li> <li>• Stainless Steel Cleaners</li> </ul>     | <p><b>CAUTION</b> Never use CHLORIDE to clean stainless steel.</p> <p>Clean stainless steel front and handles with non-abrasive soapy water and a dishcloth. Rinse with clean water and a soft cloth. Wipe stubborn spots with an ammonia-soaked paper towel, and rinse. Use a non-abrasive stainless steel cleaner. These cleaners can be purchased at most home improvement or major department stores. Always follow manufacturer's instructions.</p> <p><b>NOTE: Always clean, wipe and dry with the grain to prevent cross-grain scratching.</b> Wash the rest of the cabinet with warm water and mild liquid detergent. Rinse well, and wipe dry with a clean soft cloth.</p> |



## Care & Cleaning (continued)

### REPLACING LIGHT BULBS

Both the freezer and fresh food compartments of your refrigerator include light bulbs that will need replacing from time to time. Some lights have covers that you will need to remove before replacing the light bulbs. Always use bulbs that are designed for appliance lighting.

**CAUTION** Wear gloves when replacing light bulbs to avoid cuts.

#### To Replace Light Bulbs (some models)

1. Unplug refrigerator.
2. Wear gloves as protection against possible broken glass.
3. Unsnap light shield as shown.
4. Unscrew and replace old bulb with an appliance bulb of the same wattage.
5. Replace light shield.
6. Remember to plug the refrigerator back in.

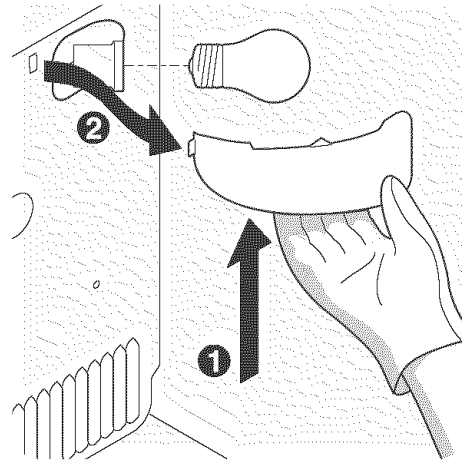

Freezer Light Cover Removal

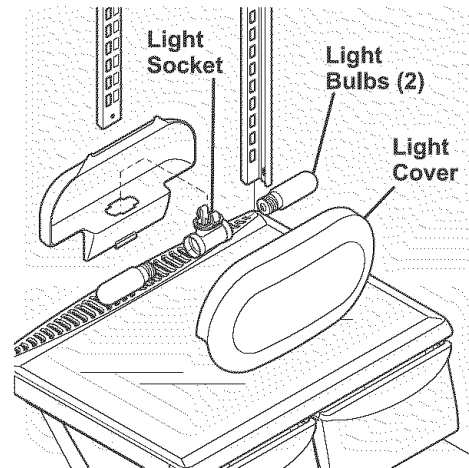

Refrigerator Mid-Level Light Cover Removal

### CONDENSER

Your refrigerator is equipped with a condenser that never needs cleaning under normal operating conditions.

## Vacation and Moving Tips

|                        |  |
|------------------------|--|
| <b>Short Vacations</b> | <ul style="list-style-type: none"> <li>• Leave refrigerator operating during vacations of 3 weeks or less.</li> <li>• Use all perishable items from refrigerator compartment.</li> <li>• Turn automatic ice maker off and empty ice bucket, even if you will only be gone for a few days.</li> </ul>   |
| <b>Long Vacations</b>  | <ul style="list-style-type: none"> <li>• Remove all food and ice if you will be gone one month or more.</li> <li>• Turn controls to "O" ( the OFF position) and disconnect power.</li> <li>• Turn off automatic ice maker and turn water supply valve to closed position.</li> <li>• Clean interior thoroughly.</li> <li>• Leave both doors open to prevent odors and mold build-up. Block doors open if necessary.</li> </ul> |
| <b>Moving</b>          | <ul style="list-style-type: none"> <li>• Remove all food and ice.</li> <li>• If using handcart, load from side.</li> <li>• Adjust rollers all the way up to protect them during sliding or moving.</li> <li>• Pad cabinet to avoid scratching surface.</li> </ul>  |



# Major Appliance Warranty Information

Your appliance is covered by a one year limited warranty. For one year from your original date of purchase, Electrolux will pay all costs for repairing or replacing any parts of this appliance that prove to be defective in materials or workmanship when such appliance is installed, used and maintained in accordance with the provided instructions.

**Exclusions**      **This warranty does not cover the following:**

1. Products with original serial numbers that have been removed, altered or cannot be readily determined.
2. Product that has been transferred from its original owner to another party or removed outside the USA or Canada.
3. Rust on the interior or exterior of the unit.
4. Products purchased "as-is" are not covered by this warranty.
5. Food loss due to any refrigerator or freezer failures.
6. Products used in a commercial setting.
7. Service calls which do not involve malfunction or defects in materials or workmanship, or for appliances not in ordinary household use or used other than in accordance with the provided instructions.
8. Service calls to correct the installation of your appliance or to instruct you how to use your appliance.
9. Expenses for making the appliance accessible for servicing, such as removal of trim, cupboards, shelves, etc., which are not a part of the appliance when it is shipped from the factory.
10. Service calls to repair or replace appliance light bulbs, air filters, water filters, other consumables, or knobs, handles, or other cosmetic parts.
11. Surcharges including, but not limited to, any after hour, weekend, or holiday service calls, tolls, ferry trip charges, or mileage expense for service calls to remote areas, including the state of Alaska.
12. Damages to the finish of appliance or home incurred during installation, including but not limited to floors, cabinets, walls, etc.
13. Damages caused by: services performed by unauthorized service companies; use of parts other than genuine Electrolux parts or parts obtained from persons other than authorized service companies; or external causes such as abuse, misuse, inadequate power supply, accidents, fires, or acts of God.

**DISCLAIMER OF IMPLIED WARRANTIES; LIMITATION OF REMEDIES**

CUSTOMER'S SOLE AND EXCLUSIVE REMEDY UNDER THIS LIMITED WARRANTY SHALL BE PRODUCT REPAIR OR REPLACEMENT AS PROVIDED HEREIN. CLAIMS BASED ON IMPLIED WARRANTIES, INCLUDING WARRANTIES OF MERCHANTABILITY OR FITNESS FOR A PARTICULAR PURPOSE, ARE LIMITED TO ONE YEAR OR THE SHORTEST PERIOD ALLOWED BY LAW, BUT NOT LESS THAN ONE YEAR. ELECTROLUX SHALL NOT BE LIABLE FOR CONSEQUENTIAL OR INCIDENTAL DAMAGES SUCH AS PROPERTY DAMAGE AND INCIDENTAL EXPENSES RESULTING FROM ANY BREACH OF THIS WRITTEN LIMITED WARRANTY OR ANY IMPLIED WARRANTY. SOME STATES AND PROVINCES DO NOT ALLOW THE EXCLUSION OR LIMITATION OF INCIDENTAL OR CONSEQUENTIAL DAMAGES, OR LIMITATIONS ON THE DURATION OF IMPLIED WARRANTIES, SO THESE LIMITATIONS OR EXCLUSIONS MAY NOT APPLY TO YOU. THIS WRITTEN WARRANTY GIVES YOU SPECIFIC LEGAL RIGHTS. YOU MAY ALSO HAVE OTHER RIGHTS THAT VARY FROM STATE TO STATE.

**If You Need Service**      Keep your receipt, delivery slip, or some other appropriate payment record to establish the warranty period should service be required. If service is performed, it is in your best interest to obtain and keep all receipts. Service under this warranty must be obtained by contacting Electrolux at the addresses or phone numbers below.

This warranty only applies in the USA and Canada. In the USA, your appliance is warranted by Electrolux Major Appliances North America, a division of Electrolux Home Products, Inc. In Canada, your appliance is warranted by Electrolux Canada Corp. Electrolux authorizes no person to change or add to any obligations under this warranty. Obligations for service and parts under this warranty must be performed by Electrolux or an authorized service company. Product features or specifications as described or illustrated are subject to change without notice.

**USA**  
**1.800.944.9044**  
Electrolux Major Appliances  
North America  
P.O. Box 212378  
Augusta, GA 30907



**Canada**  
**1.800.668.4606**  
Electrolux Canada Corp.  
5855 Terry Fox Way  
Mississauga, Ontario, Canada  
L5V 3E4

# ATTENTION

*To Properly Install Your Refrigerator  
See "Installation" Section On Pages 4-5*



## *Before You Call*

| <p><b>Common Occurrences</b></p>  | <p>Before calling for service, review this list. It may save you time and expense. This list includes common occurrences that are not the result of defective workmanship or materials in this appliance.</p>  |
|---|--|
| <p><b>Refrigerator does not run.</b></p>  | <ul style="list-style-type: none"> <li>• Ensure plug is tightly pushed into electrical outlet.</li> <li>• Check/replace fuse with a 15 amp time-delay fuse. Reset circuit breaker.</li> <li>• The temperature control is turned to "O".</li> <li>• Refrigerator may be in defrost cycle. Wait 20 minutes and check again.</li> </ul> |
| <p><b>Freezer temperature too cold.<br/>Refrigerator temperature is satisfactory.</b></p> | <ul style="list-style-type: none"> <li>• Set freezer control to a warmer setting until freezer temperature is satisfactory. Allow 24 hours for the temperature to stabilize.</li> </ul>  |
| <p><b>Refrigerator temperature too cold.<br/>Freezer temperature is satisfactory.</b></p> | <ul style="list-style-type: none"> <li>• Set refrigerator control to a warmer setting. Allow 24 hours for temperature to stabilize. Then check freezer temperatures and adjust as needed.</li> </ul>   |
| <p><b>* Refrigerator is noisy or vibrates.</b></p>  | <ul style="list-style-type: none"> <li>• The cabinet is not level.</li> <li>• Floor is weak.</li> </ul>  |
| <p><b>Odors in refrigerator.</b></p>  | <ul style="list-style-type: none"> <li>• Interior needs to be cleaned.</li> <li>• Foods that produce odors should be covered or wrapped.</li> </ul>  |
| <p><b>Cabinet light not working.</b></p>  | <ul style="list-style-type: none"> <li>• Replace light bulb.</li> <li>• Ensure plug is tightly pushed into electrical outlet.</li> <li>• Light switch may be stuck. Push in light switch, located on the refrigerator control box, to release.</li> </ul>  |
| <p><b>Automatic ice maker not working.<br/>(some models)</b></p>                          | <ul style="list-style-type: none"> <li>• Ensure the Wire Signal Arm is not in UP position.</li> <li>• Ice maker should produce 4 to 5 pounds of ice in a 24 hour period.</li> <li>• Water supply is turned off.</li> <li>• Water pressure is too low.</li> <li>• The freezer is not cold enough.</li> </ul>                          |

\* See Normal Operating Sounds and Sights.