

SERVICE DATA SHEET

Gas Ranges with ES 200/205/300 & 305 Electronic Oven Controls

NOTICE - This service data sheet is intended for use by persons having electrical and mechanical training and a level of knowledge of these subjects generally considered acceptable in the appliance repair trade. The manufacturer cannot be responsible, nor assume any liability for injury or damage of any kind arising from the use of this data sheet.

SAFE SERVICING PRACTICES

To avoid the possibility of personal injury and/or property damage, it is important that safe servicing practices be observed. The following are examples, but without limitation, of such practices.

- Before servicing or moving an appliance remove power cord from electrical outlet, trip circuit breaker to OFF, or remove fuse.
- Never interfere with the proper installation of any safety device.
- GROUNDING:** The standard color coding for safety ground wires is *GREEN* or *GREEN WITH YELLOW STRIPES*. Ground leads are not to be used as current carrying conductors. **It is extremely important that the service technician reestablish all safety grounds prior to completion of service. Failure to do so will create a potential safety hazard.**
- Prior to returning the product to service, ensure that:
 - All electric connections are correct and secure.
 - All electrical leads are properly dressed and secured away from sharp edges, high-temperature components, and moving parts.
 - All uninsulated electrical terminals, connectors, heaters, etc. are adequately spaced away from all metal parts and panels.
 - All safety grounds (both internal and external) are correctly and securely reassembled.

CONVECTION/SPEED BAKE MODE (some models)

The Speed Bake mode uses the addition of a fan to move the heated air already in the oven. Moving the heated air helps to destratify the heat and cause uniform heat distribution. Cooking times can be reduced by as much as 30%. The air is drawn in through a fan shroud located in the rear wall of the oven. It is then discharged around the outer edges of this shroud. The air circulates around the food and then enters the shroud again. As with conventional gas ranges, there is still an oven vent which discharges behind the top cooking surface.

To set the oven to Speed Bake mode, follow these steps:

- Program the oven as you normally would for baking.
- Push and release the **Convection/Speed Bake** momentary rocker switch. The indicator light will glow, signifying that the Convection/Speed Bake mode has been activated. **The fan will not come on for the first six minutes, unless the center of the oven temperature is above 350°F when the Speed Bake mode is activated.** This is to allow for clean combustion in the gas oven. Six minutes after the Speed Bake mode is activated, the fan will come on. The fan stays on when the oven door is closed and shuts off while the oven door is opened. The fan will continue to operate until baking is complete.
- To cancel the Speed Bake function, press **CANCEL** or **CLEAR** on the oven control as you would to cancel any baking function.

NOTE: The **Speed Bake** mode will not work during a clean or broil cycle.

FAN MOTOR (Convection/Speed Bake models only)

The fan motor is mounted on the main back on the back side of the range. It can be accessed by removing the rear wire shields.

FAN BLADE (Convection/Speed Bake models only)

The fan blade is mounted in the rear of the unit and has a "D" shaped mounting hole. Only minimum clearance exists between the oven back, fan blade, and fan shroud. Be careful not to bend the blade when removing or installing. Access to the fan blade is gained by removing the fan shroud located inside the oven and held in place by two screws. The fan blade is held in place with a 13 mm hex nut that has **left handed threads**. When removing this nut, gently hold the fan blade, and turn the nut clockwise. If one of the blades becomes deformed, it may be bent back into shape using a flat surface as a reference. A flat washer is located on the motor shaft between the snap ring on the shaft and the fan blade.

Note: If the fan blade is bent and the motor vibrations increase, the noise made by the fan will be greater.

FAN OPERATION (Convection/Speed Bake models only)

The fan motor runs continuously (after the first six minutes, as defined above) while in Convection/Speed Bake mode unless the door is opened. If the fan does not operate, check the following:

- Is the oven control in Bake mode?
- Is the Speed Bake indicator light glowing?
- Are 120 volts available at the fan motor?
- Is the fan motor coil resistance 35 ohms $\pm 10\%$?
- Is the door/light switch working properly?

MOTOR MOUNTING BRACKET (Convection/Speed Bake models only)

The fan motor on the rear of the range is mounted through the main back to a mounting bracket that is attached with three screws to the backside of the rear oven wall. Should it become necessary to replace this bracket, the main back must be removed to access the mounting screws.

RTD SCALE	
Temperature (°F)	Resistance (ohms)
32 \pm 1.9	1000 \pm 4.0
75 \pm 2.5	1091 \pm 5.3
250 \pm 4.4	1453 \pm 8.9
350 \pm 5.4	1654 \pm 10.8
450 \pm 6.9	1852 \pm 13.5
550 \pm 8.2	2047 \pm 15.8
650 \pm 9.6	2237 \pm 18.5
900 \pm 13.6	2697 \pm 24.4

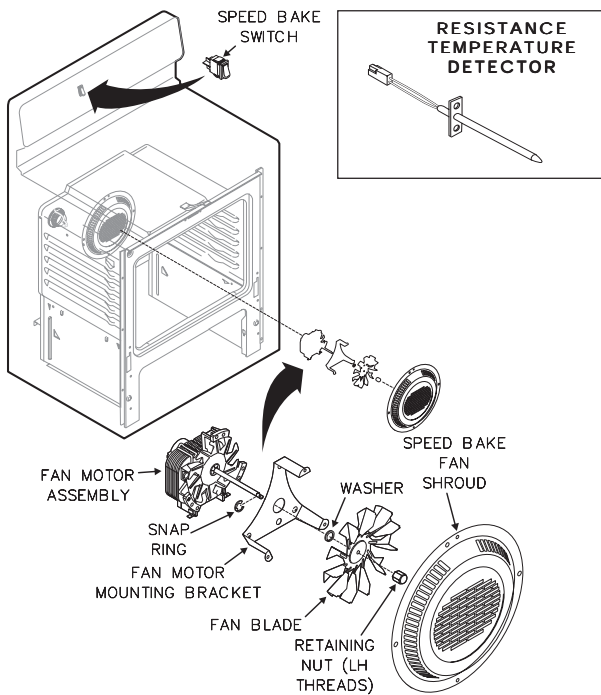

ELECTRONIC OVEN CONTROL (REAR VIEW)

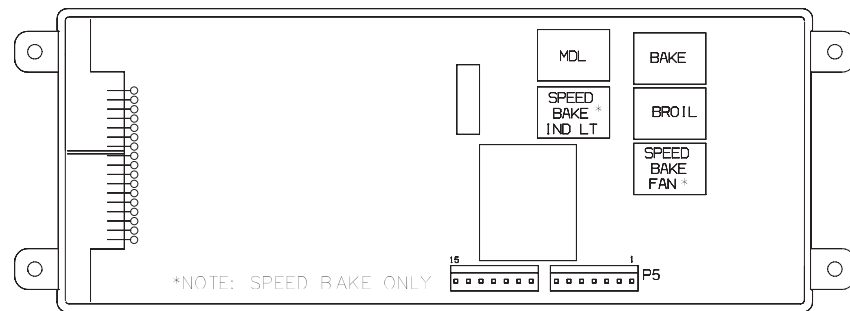

OVEN CALIBRATION

Set the electronic oven control for normal baking at 350°F. Obtain an average oven temperature after a minimum of 5 cycles. Press **CANCEL** or **CLEAR** to end bake mode.

TEMPERATURE ADJUSTMENT

- Set EOC to bake at 550°F.
- Within 5 seconds of setting 550°F, press and hold the bake pad for approximately 15 seconds until a single beep is heard (longer may cause **F11** shorted keypad alarm).
- Calibration offset should appear in the display.
- Use the slew keys to adjust the oven temperature up or down 35°F in 5°F increments.
- Once the desired (-35° to 35°) offset has been applied, press **CANCEL** or **CLEAR**.

Note: Changing calibration affects both Speed Bake and normal bake modes. The adjustments made will not change the self-cleaning temperature.

ELECTRONIC OVEN CONTROL FAULT CODE DESCRIPTIONS

Fault Code	Likely Failure Condition/Cause	Suggested Corrective Action
F10	Runaway Temperature.	1. (F10 only) Check RTD Sensor Probe & replace if necessary. If oven is overheating, disconnect power. If oven continues to overheat when the power is reapplied, replace EOC. Severe overheating may require the entire oven to be replaced should damage be extensive. 2. (F11, 12 & 13) Disconnect power, wait 30 seconds and reapply power. 3. (F11, 12 & 13) If fault returns upon power-up, replace EOC.
F11	Shorted Keypad.	
F12	Bad Micro Identification.	
F13	Bad EEPROM Identification/Checksum error.	
F30	Open probe connection.	1. (F30 or F31) Check resistance at room temperature & compare to RTD Sensor resistance chart. If resistance does not match the RTD chart replace RTD Sensor Probe. Check Sensor wiring harness between EOC & Sensor Probe connector. 2. (F30 or F31) Check resistance at room temperature, if less than 500 ohms, replace RTD Sensor Probe. Check for shorted Sensor Probe harness between EOC & Probe connector.
F31	Shorted Probe connection.	
F90	Maximum oven door unlock time exceeded.	1. (F90, 91, 92, 93 & 94) Check the wiring between EOC & Lock Motor Micro Switch. 2. (F90, 91, 92, 93 & 94) Replace the Motor Door Latch assembly if necessary. 3. (F90, 91, 92, 93 & 94) Check for binding of the Latch Cam, Lock Motor Rod & Lock Motor Cam. 4. (F90, 91, 92, 93 & 94) Check to see if Lock Motor Coil is open. If open, replace Lock Motor Assembly. 5. (F90, 91, 92, 93 & 94) Lock Motor continuously runs - if Micro Switch is open, replace Lock Motor Assembly. 6. (F92, 93 & 94) Check oven door Light Switch - if open, replace Switch. 7. If all situations above do not solve problem, replace EOC.
F91	Maximum oven door unlock attempts exceeded.	
F92	Maximum oven door open time exceeded.	
F93	Maximum oven door lock time exceeded.	
F94	Maximum oven door lock attempts exceeded.	

REMOVING AND REPLACING WARMER DRAWER (some models)

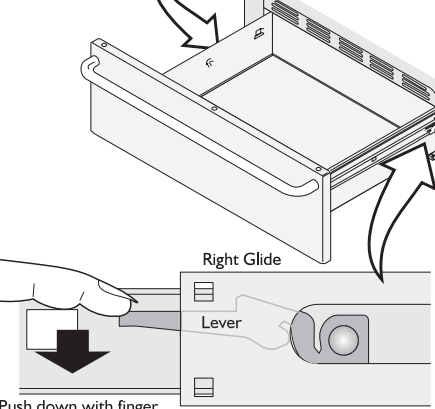
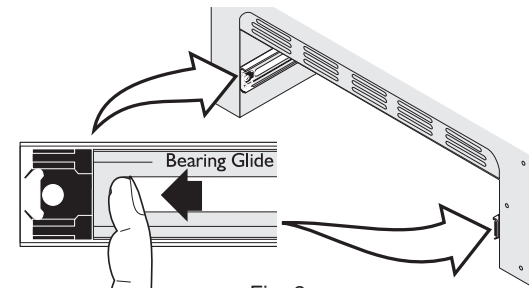
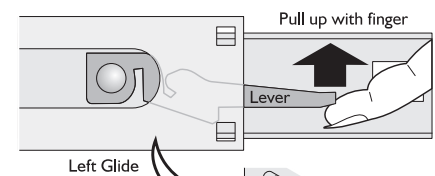
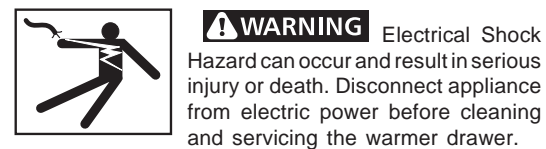

To Remove Warmer Drawer:

- CAUTION** Turn power off before removing the warmer drawer.
- Open the drawer to the fully opened position.
- Locate glide lever on each side of drawer, pull up on the left glide lever and push down on the right glide lever (see Fig. 1).
- Pull the drawer away from the range.

To Replace Warmer Drawer:

- Pull the bearing glides to the front** of the chassis glide (see Fig. 2).
- Align the glide on each side of the drawer with the glide slots on the range.
- Push the drawer into the range until levers "click" (approximately 2"). Pull the drawer open again to seat bearing glides into position. **If you do not hear the levers "click" or the bearing glides do not feel seated remove the drawer and repeat steps 1 thru 3.** This will minimize possible damage to the bearing glides.

IMPORTANT
DO NOT REMOVE THIS BAG
OR DESTROY THE CONTENTS
WIRING DIAGRAMS AND SERVICE
INFORMATION ENCLOSED
REPLACE CONTENTS IN BAG

CIRCUIT ANALYSIS MATRIX

	EOC Relays					Door Switch COM-NO	Warmer Drawer Lock Switch (Motor Door Latch)
	L1 to Bake	L1 to Broil	L1 to Motor Door Latch	L1 to Speed Bake Fan	L1 to Speed Bake Indicator Light		
Bake/Time Bake	X						X
Speed Bake	X			X	X		X
Broil		X					X
Clean	X						
Unlocked							X
Locking			X				X
Locked							
Unlocking			X				X
Door Open							
Door Closed						X	

Note: X=Check listed circuits

ELECTRONIC OVEN CONTROL (EOC) TROUBLESHOOTING GUIDE

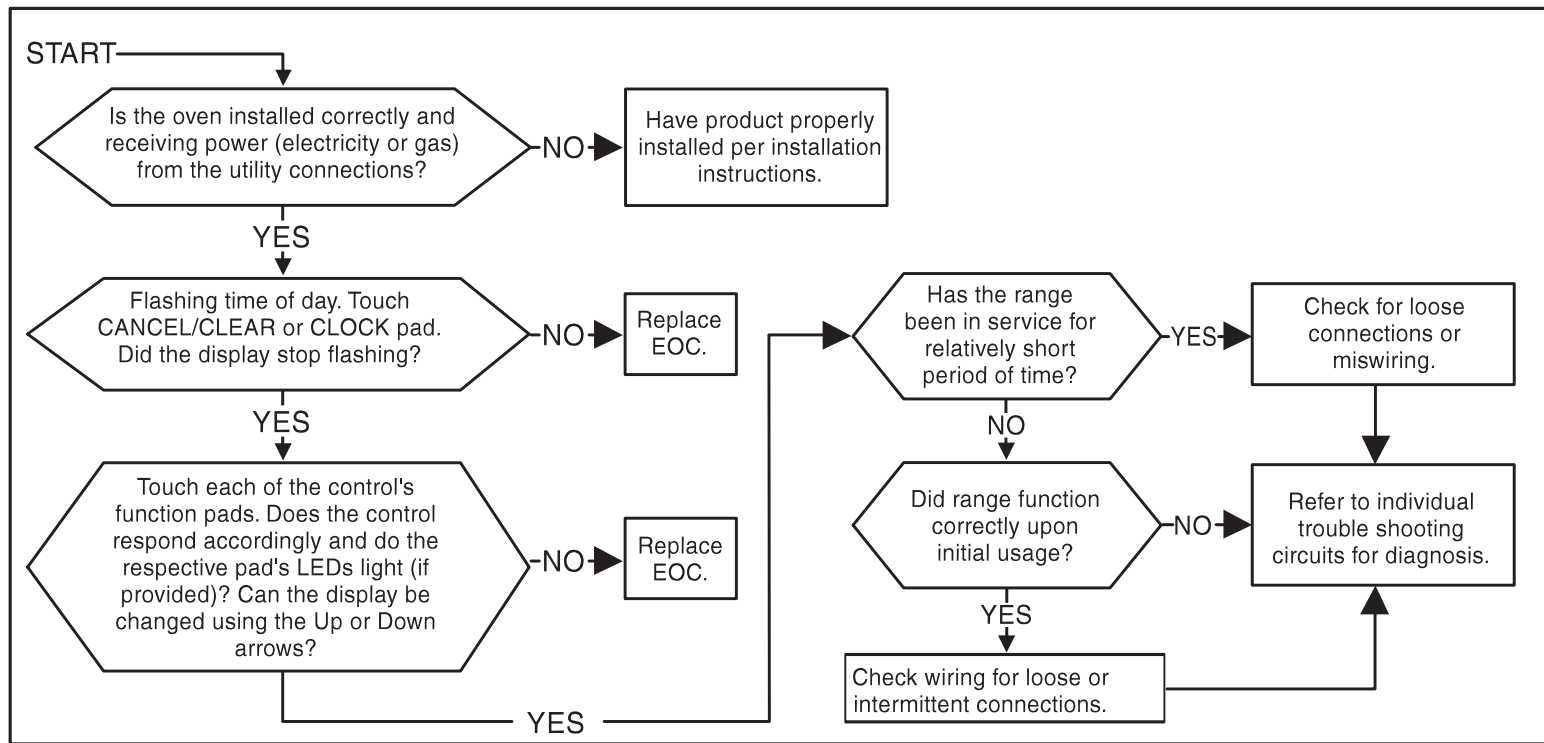

E.O.C. CONTROL CONNECTIONS (P5)

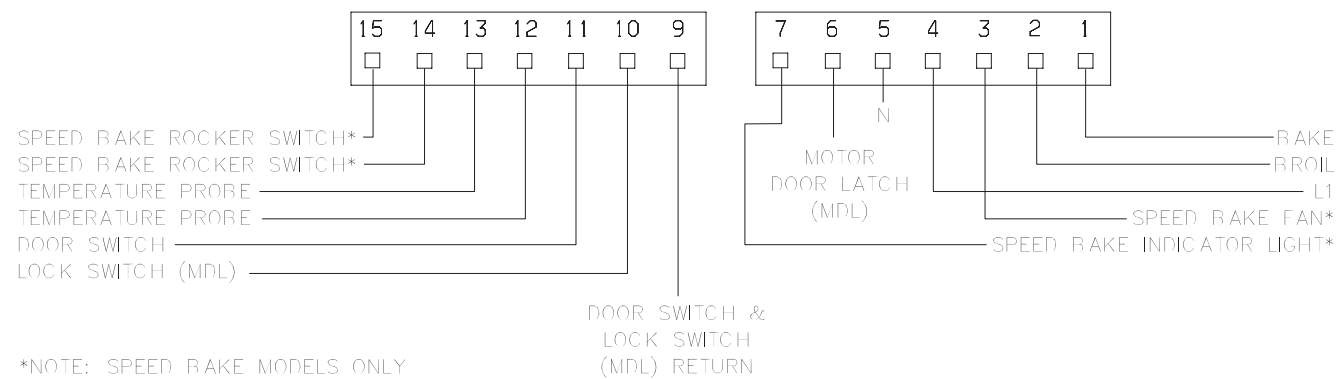

*NOTE: SPEED BAKE MODELS ONLY

TROUBLESHOOTING SCHEMATICS

NOTE: CIRCUITS SHOWN WITH ALL CONTROLS SET TO OFF. OVEN DOOR CLOSED AND UNLOCKED.

