

Whirlpool 30-INCH FREE-STANDING
ELECTRIC RANGE
Model RJE-385P

**USE AND CARE
GUIDE**

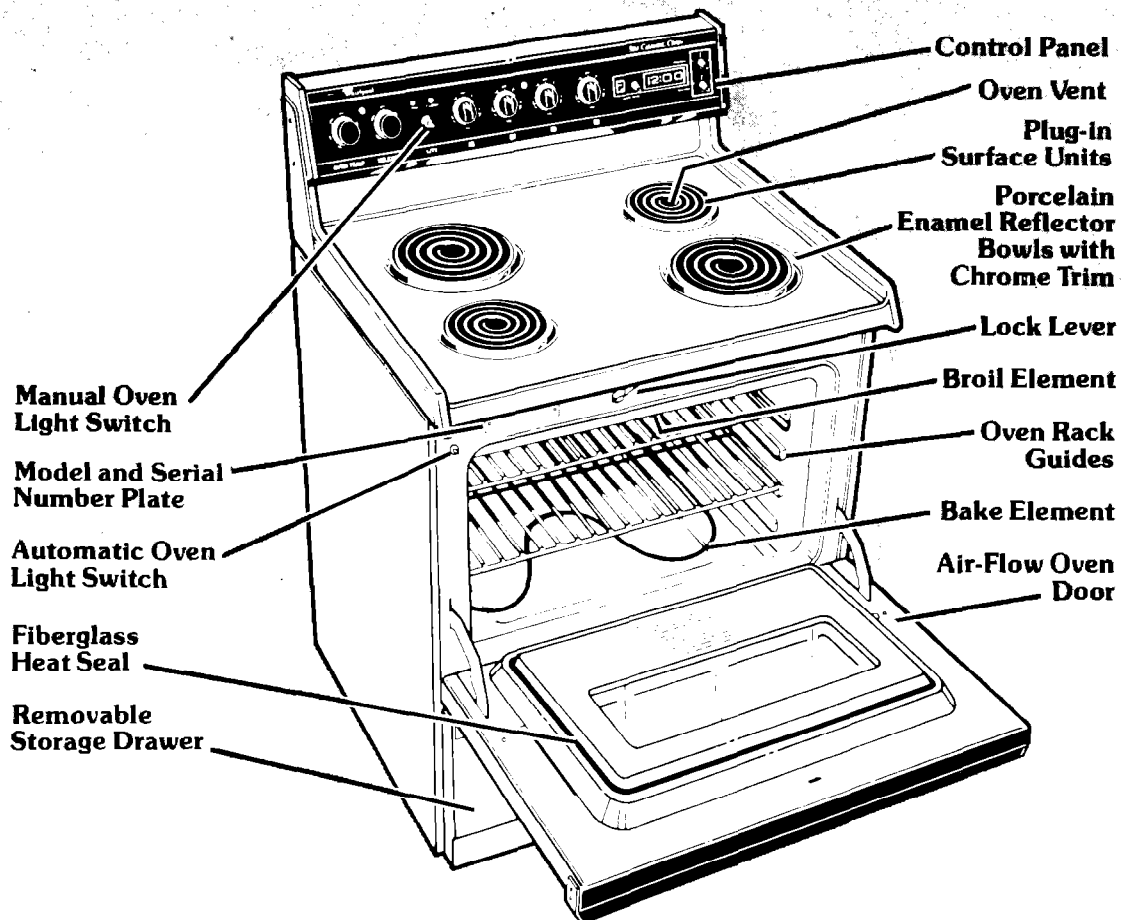

Copy Your Model and Serial Numbers Here

When you need service, or call with a question, have this information ready:

- 1 **Complete** Model and Serial Numbers (from the plate just behind the top of the oven door).
- 2 Purchase date from sales slip (or date installed).

Copy this information in these spaces. Keep this book, your warranty and sales slip together in a handy place.

_____	Model Number
_____	Serial Number
_____	Purchase and Installation Date
_____	Service Company and Phone Number

See Cooking Guide for important safety information.

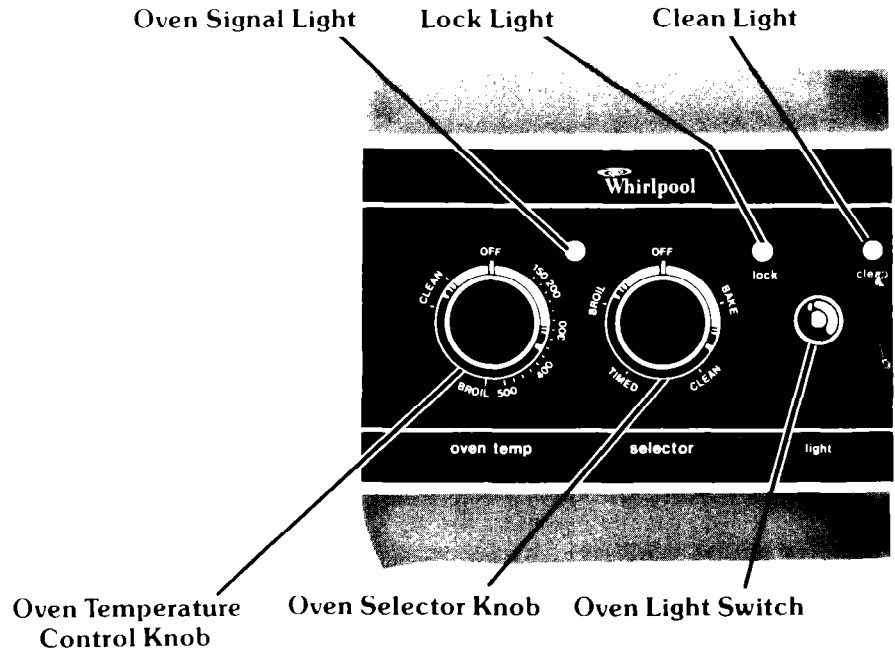
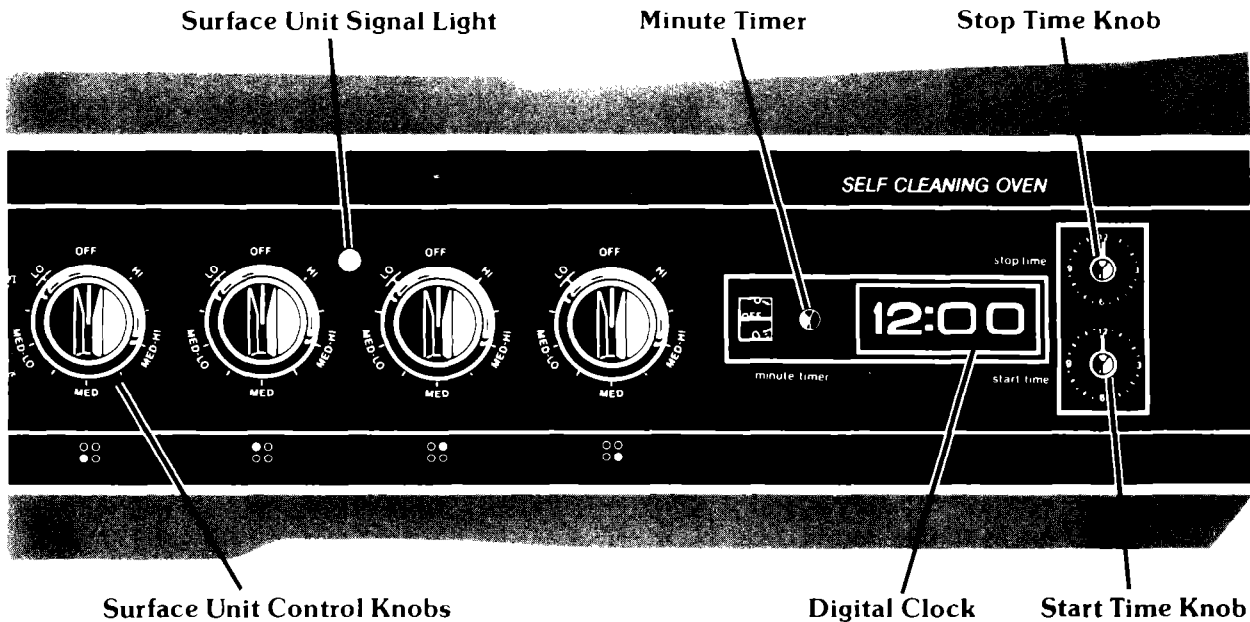

Table of Contents

	Page
BEFORE USING YOUR RANGE	3
USING THE SURFACE UNIT CONTROLS	4
USING THE OVEN CONTROLS	4
• Baking	4
• Broiling	4
• Variable Broil Feature	5
• Resetting the Oven Temperature Control Knob	5
SETTING THE CLOCK TO THE CORRECT TIME OF DAY	6
USING THE MINUTE TIMER	6
USING THE AUTOMATIC MEALTIMER™ CLOCK	6
OVEN RACK POSITIONS	8
USING THE OVEN LIGHT	8
THE OVEN VENT	8
THE OPTIONAL ROTISSERIE	9
USING THE SELF-CLEANING OVEN	9
CLEANING AND CARING FOR YOUR RANGE	12
• Removing and Replacing Control Knobs	12
• Cleaning Under the Cooktop	13
• Removing the Storage Drawer	13
• Cleaning Chart	14
IF YOU NEED SERVICE OR ASSISTANCE	15
1. Before Calling for Assistance	15
2. If You Need Assistance	16
3. If You Need Service	16
4. If You Have a Problem	16



Before using your range

IMPORTANT

We build appliances to last, but we can't control how they are used. Before using it, you are personally responsible for making sure that it...

- is properly installed and leveled on a floor that will hold the weight, and in a well-ventilated room.
- is connected only to the right kind of outlet, with the right electric supply and grounding.
- is used only for jobs expected of home ranges
- is out of the weather.
- is properly maintained.
- is **not** used by children or others who may not understand how it should be used.

SAFETY FIRST

- **Do not let children use or play with the range.**
- **Use your range only for the job it is intended to do.**
- **Read the "Cooking Guide" for important safety information. It also has other general hints for the care and use of your range.**
- **Read the Installation Instructions for complete information.**

Using the surface unit controls

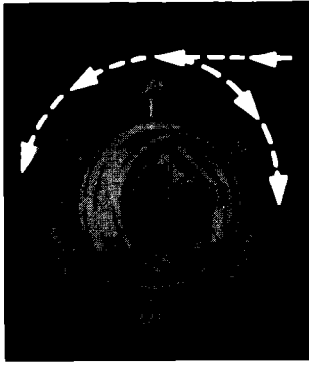

PUSH IN and turn to setting.

The Surface Unit Control Knobs must be pushed in before turning them. This helps avoid turning them on accidentally when wiping off the Control Panel. And it helps keep small children from turning them on. **You must push in on them...then turn to the setting you want.**

A design by each knob tells which unit is turned on by that knob. (For example, [●] shows that the right front unit...the one closest to you on your right...will heat when you push in and turn that knob.)

The knob may be set anywhere between "HI" and "OFF." As you use your surface units, you will get used to the settings that match your pots, pans and favorite foods the best.

As a guide, the setting should cook at about the following heats:

- HI** -- To start most foods cooking. To bring water to a boil.
- MED-HI** -- To hold a rapid boil, to fry pancakes or chicken.
- MED** -- To make gravy, puddings and icings; to cook large quantities of vegetables.
- MED-LO** -- To keep food cooking after starting it at a higher setting.
- LO** -- To keep food warm until ready to serve. You will notice that you can set the heat higher or lower within the LO band. [LO] to help keep food at the temperature you want.

The Signal Light will glow whenever a Surface Unit is on. Be sure this light is off when you have finished cooking.

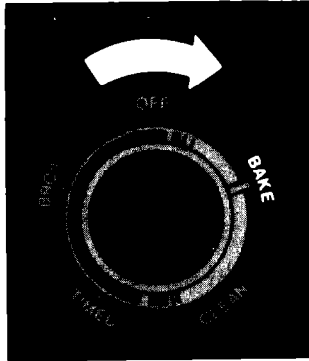

To bake, turn the Oven Selector Knob to BAKE.

Using the oven controls

Baking:

First -- Follow the directions on page 8 for "Positioning Oven Racks."

Second -- Turn the Oven Selector Knob to "BAKE."

Third -- Turn the Oven Temperature Control Knob to the baking temperature you want. The Oven Signal Light will glow while the oven is heating. When this light goes off, the oven has heated to the temperature you set.

Fourth -- Place food in oven. The heating elements turn off and on during baking to keep the oven at the temperature you set. The Oven Signal Light will glow when the heating elements are on.

Fifth -- When the baking is done, turn both the Oven Temperature and Oven Selector Knobs to "OFF."

NOTE: Do not lock the oven door during baking. If you do, you may not be able to unlock it until the oven has cooled.

Broiling:

First -- Follow the directions on page 5 for placing the meat at the right distance from the Broil Element.

Second -- Turn the Oven Selector to "BROIL."

Third -- Turn the Oven Temperature Control Knob to "BROIL" or turn it to a lower temperature (see "Variable Broil Feature," on page 5).

Fourth -- Put the broiler pan on the oven rack.

Fifth -- Keep the oven door open about four inches (10 cm). There is a stop in the hinges to hold it there. The Oven Signal Light will glow while the broil element is on.

Sixth -- When you are through, turn both the Oven Temperature Control and the Oven Selector Knobs to "OFF."

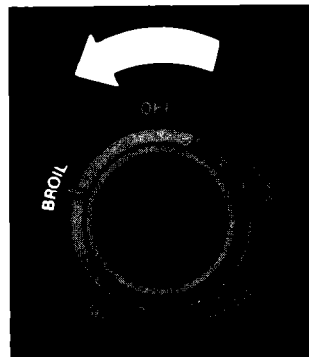

To broil, turn the Oven Selector Knob to BROIL.

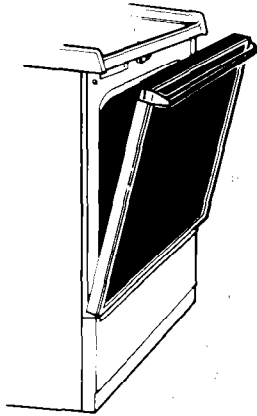

ALWAYS broil with the door open about 4 inches (10 cm).

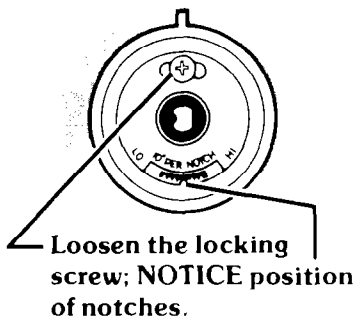

Loosen the locking screw; NOTICE position of notches.

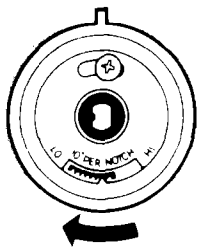

Lower: move black part toward "LO." One notch equals about 10°F (5°C).

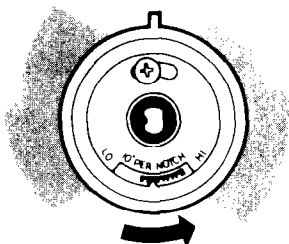

Higher: move black part toward "HI." One notch equals about 10°F (5°C).

The following chart suggests broiling times and oven-rack positions for different kinds of meats when the Oven Selector Knob is set to BROIL.

Food	Description	Inches (cm) from top of food to Broil Element	Approximate Minutes	
			1st side	2nd side
Beef Steaks				
Rare	1" (2.5 cm)	3" (8 cm)	7-9	3-5
Medium	1" (2.5 cm)	3" (8 cm)	9-11	4-7
Well done	1" (2.5 cm)	3" (8 cm)	11-13	5-7
Beef Steaks				
Rare	1 1/2" (4 cm)	4" 5" (10-13 cm)	13-15	6-8
Medium	1 1/2" (4 cm)	4" 5" (10-13 cm)	17-19	8-10
Well done	1 1/2" (4 cm)	4" 5" (10-13 cm)	19-21	14-16
Hamburgers	1/2" (1 cm)	3" (8 cm)	6-8	4-5
Lamb Chops				
Medium	1" (2.5 cm)	3" (8 cm)	6-8	4-5
Ham slice, precooked or tendered	1/2" (1.25 cm)	3" (8 cm)	6-8	4-5
Canadian Bacon	1/2" (1 cm)	3" (8 cm)	6	4
Pork Rib or Loin Chop	3/4" (1.75 cm)			
Well done	2" (2.5 cm)	4" 5" (10-13 cm)	15	10
Chicken	2-3 lb (1-1.5 kg) cut in half	7" 9" (18-23 cm)	25-30	10-12
Fish	whole	3" (8 cm)	11-16	9-14
	fillets	3" (8 cm)	7-8	5-7
Liver	1/2" (1.25 cm)	3" (8 cm)	3	3
Frankfurters		4" 5" (10-13 cm)	6-7	4-5

Variable Broil Feature:

You might want to broil some foods slower than others. Broiling can be slowed down by setting a lower temperature on the Oven Temperature Control Knob instead of "BROIL." Using a lower temperature will cause the broil element to turn on and off during the broiling so that the food broils more slowly.

When the Oven Temperature Control Knob is on "BROIL," the Broil Element heats all the time. Set the temperature lower and it heats some of the time. The lower the temperature setting, the shorter are the periods of heating.

NOTE: The Oven Selector must be in the "BROIL" position in order for the Broil Element to heat.

Resetting the Oven Temperature Control:

Does your new oven seem hotter or colder than your old oven? The temperatures in older ovens often shift very gradually, getting hotter or colder without the user really noticing the change. Your new oven is properly adjusted to provide accurate temperatures, but when compared to your old range, the new design may give you different baking results. If you think that the temperature setting on your range needs to be hotter or colder, you can adjust the Oven Temperature Control Knob by yourself.

To adjust the setting, first pull the Oven Temperature Control Knob straight off. On the back, just across from the locking screw, are a row of notches on the black part of the knob and one tooth on the chrome part.

To set your oven about 10°F(5°C) **cooler**, loosen the locking screw about two full turns and move the row of notches **one notch** closer to "LO." To set your oven about 10°F(5°C) **warmer**, move the row of notches **one notch** closer to "HI." Each notch equals about 10°F(5°C).

Tighten the locking screw and put the knob back on the control panel.

Setting the clock to the correct time of day

1. Push in the Minute Timer Knob and turn it clockwise until the digits show the correct time of day.
2. The Minute Timer dial will turn as you set the clock. When clock is set, let the knob pop out. Then, while it is out, turn the Minute Timer hand counter-clockwise to "OFF." **If you push in on the knob when setting the Minute Timer, you will change the setting of the clock.**

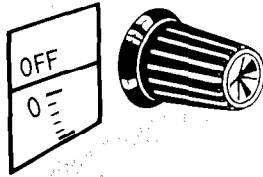

Minute Timer

Using the Minute Timer

Without pushing it in, turn the knob until the minutes you want to time show in the window. When the time you set is up, a buzzer will sound. Turn the dial to "OFF" to stop the buzzer.

The Minute Timer does not start or stop cooking. It only buzzes when the time you set is up. It can be used to time almost any cooking operation. It can even remind you of other things (like when to add softener to the washer).

For the most accurate timing, turn the knob past the time you want. Then turn it back to the setting. Do not push in on the knob while setting the Minute Timer. Pushing in the knob while turning will change the setting on the clock.

Using the automatic MEALTIMER® clock

The automatic feature of the MEALTIMER® Clock lets you be away from home when the oven starts, or when it stops. It will turn on and off automatically, or just turn off automatically.

Let's say you have a roast that will take four hours to cook. Dinner is supposed to be at 6:00, but you have an appointment at 1:30 and you know you won't get home until at least 4:00. When do you have time to put in the roast?

With the Automatic MEALTIMER® Clock, it's easy. Just before you leave for your appointment, put the roast in the oven, set the start time for 2:00 and the stop time for 6:00 (four hours). Set the Oven Selector to "TIMED" and set the Oven Temperature Control Knob for the temperature you want. Then leave. The oven will start at 2:00, bake for four hours at the selected temperature, and shut off at 6:00.

†Tmk

To start and stop your oven automatically:

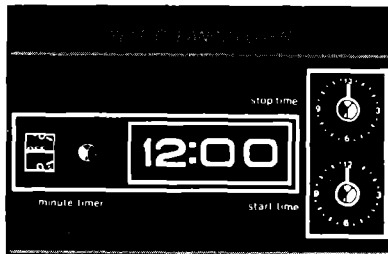

1. Be sure the clock is set to the right time of day. (The start and stop time hands will also show the correct time.)

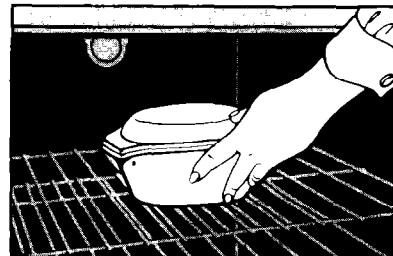

2. Place the food in the oven.

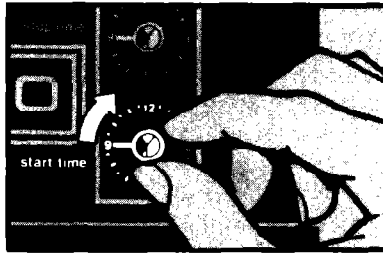

3. Push in and turn the **Start Time Knob** clockwise to the time you want the oven to start.

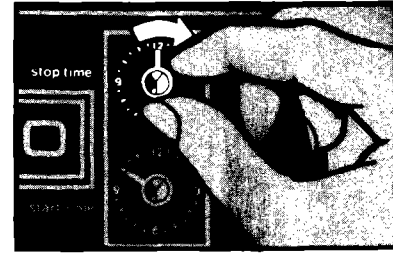

4. Push in and turn the **Stop Time Knob** clockwise to the time you want the oven to stop.

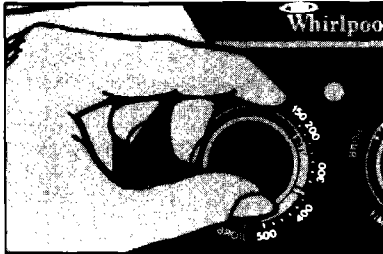

5. Turn the **Oven Temperature Control Knob** to the temperature you want to use to cook the food.

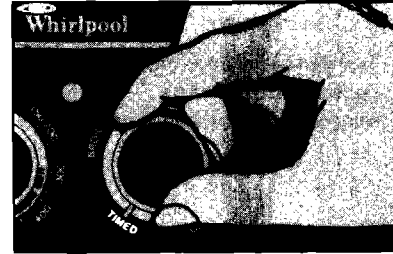

6. Set the **Oven Selector** to "TIMED."

When cooking is finished, turn both the Oven Selector and the Oven Temperature Control Knobs to "OFF."

If you want to stop the oven before it stops automatically, turn the Temperature and Selector Knobs to "OFF." Remove food from the oven. You don't have to do anything with the Stop Time Knob.

When you want the oven to start now, but stop automatically:

1. Be sure the clock and the start and stop time hands show the right time of day.
2. Put the food in the oven.
3. Push in and turn the Stop Time Knob to the time you want the oven to stop cooking.
4. Turn the Oven Selector to "TIMED" and the Oven Temperature Control to the temperature setting you want.
5. When cooking is finished, turn the Oven Selector and Temperature Control Knobs to "OFF."

WHEN USING THE AUTOMATIC STARTING TIME:

Use foods that will not go bad or spoil while standing in the oven before cooking starts. Avoid using dishes with milk or eggs, cream soups, cooked meats or fish, and bread dough with baking powder or yeast.

Smoked or frozen meats may be used; vegetables, fruits and casserole-type foods are good choices. Vegetables can be cooked in a covered baking dish with about a half-cup (118 mL) of water for 1 to 1½ hours.

Any food to be cooked with a delayed start should be very cold or frozen before it is placed in the oven. MOST UNFROZEN FOODS SHOULD NEVER STAND MORE THAN TWO HOURS BEFORE COOKING STARTS.

Oven rack positions

Your oven has two racks. Always put the racks where you want them to be **before you turn on the oven.**

To remove a rack, take hold of it on the front edge and pull it out until it stops. Then lift up the front edge and pull again. It will slide past the stops, out of the guides and out of the oven.

To put it back, fit the back corners into the guides at each side of the oven and slide it in, **keeping the front tilted up until the rack passes the stops in the rack guides.**

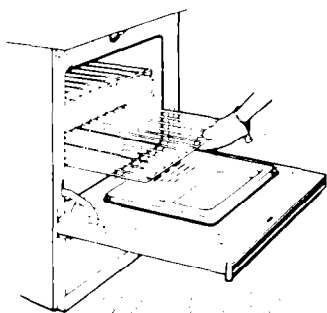

To remove rack, pull forward until rack stops, lift front and pull.

For:	Place Rack:
Baking	On the second or third rack guide from the top so food is in the center of the oven.
Broiling	So food is about the distance from the broil element suggested in the broiling timetable under "Using the Oven Controls."
Roasting LARGE cuts of meat	On the bottom rack guides
Roasting SMALLER cuts of meat	So food is in the center of the oven.

When baking, always leave at least 1½ to 2 inches (4-5 cm) of air space between the sides of a pan and other pans and the oven wall for air circulation.

For best results, get additional information on placing pans, cookie sheets and other utensils from the "Cooking Guide."

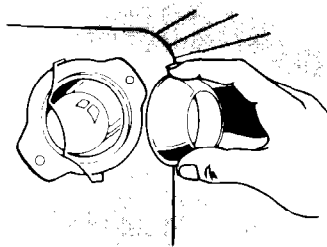

To replace the oven light, remove glass cover.

Using the oven light

The oven light will come on when the oven door is opened. To turn on the light without opening the door, push the oven light switch. Push it again to turn the light off.

To replace the oven light bulb:

The oven light bulb has a glass cover which is held on by a wire holder. **This cover must be in place** when the oven is being used.

1. Turn off the electric power at the main power supply.
2. Pull out on the wire holder and move it to one side. This will let you remove the glass cover.
3. Replace the bulb with a 40-watt **appliance** bulb (designed to stand up to oven heat) available at most grocery, variety and hardware stores.
4. Replace glass cover. Snap the wire holder in place.

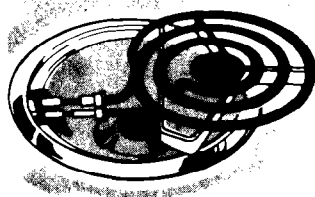

Oven vents through right rear surface unit.

The oven vent

There is an oven vent under the right rear surface element. When the oven is on, heated air will escape through it. A vent is needed for air circulation in the oven during baking. You can cook on this surface unit while the oven is on. A warm pan of food will stay warm on this unit while the oven is on. It may be warm enough to melt butter, too.

Do not try to save heat or energy by blocking the vent. Poor baking can result. Plastic utensils may melt if they are over the vent while the oven is on.

The optional rotisserie

If you would like a rotisserie with your oven, you can order a kit from your dealer. Easy installation instructions come with the kit.

Using the Self-Cleaning oven cycle

The Self-Cleaning Oven uses high heat that actually burns away oven soil. For best results and safety, read this section carefully. Make sure you understand how everything works before you set your oven to "CLEAN."

Things to do before you start:

- Some areas may not be cleaned during the Self-Cleaning cycle:
 - The frame around the oven opening.
 - The door, especially the part around the outside of the oven seal. Soil on these areas will be more difficult to remove after the Self-Cleaning cycle. Use hot water and detergent... or a soapy steel-wool pad. Rinse well.
- **Do not move or bend the fiberglass oven door seal. Do not try to clean it by hand.**
- The high heat during the cleaning cycle will discolor the racks and take the shine off them if they are left in the oven during the Self-Cleaning cycle. If you want your oven racks to stay shiny and bright, take them out before starting the cleaning cycle. If you do clean the racks during the cleaning cycle, read the "Special Tips" at the end of this section.
- Don't leave any pots or pans in the oven during cleaning. They won't be able to stand the high heat.
- Wipe up spills, overflows, boilovers and grease that hasn't baked onto the bottom of the oven. This will help reduce smoking during the cleaning cycle.
- The porcelain reflector bowls may be cleaned in the oven. Put the oven racks on the second and top rack guides. Wipe the reflector bowls and put two reflector bowls **upside down** on each rack. For best results, they should not touch each other or the oven walls. **Chrome trim rings must not be cleaned in the oven.**
- Turn on the vent, hood fan or other kitchen vents during the cleaning cycle. This will help remove smoke, odor and heat that are normal during the cycle.
- If you have a rotisserie, be sure the motor socket cover is closed.

Setting the controls to the Self-Cleaning cycle:

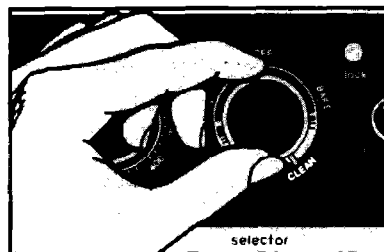

1. Set the Oven Selector Knob to "CLEAN."

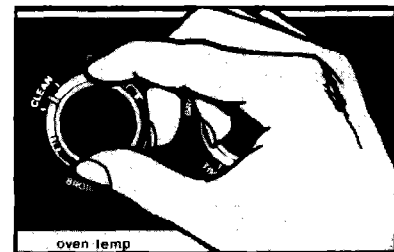

2. Set the Oven Temperature Control Knob to "CLEAN."

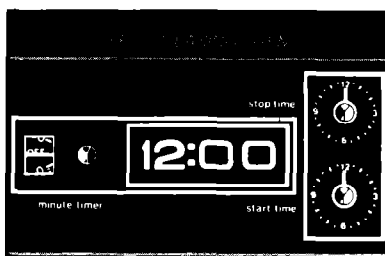

3. The clock and dials for start and stop time should all have the right time of day.

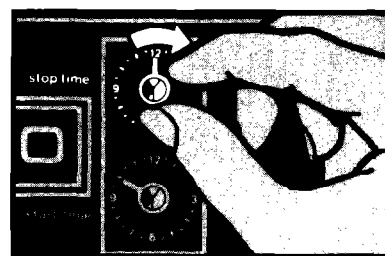

4. Push in on the Stop Time Knob and set it ahead as many hours as you want for the cleaning cycle. For a lightly soiled oven, two hours ahead may be enough. For heavy soil, three hours ahead may be about right. If some soil does not get removed during the cleaning cycle, see "Special Tips" later in this section.

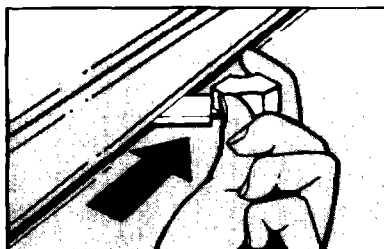

5. Lock the oven door by moving the Lock Lever all the way to the right. When it is all the way over, the Clean Light will come on. If the Clean Light doesn't come on, the lever isn't all the way over and the cleaning cycle won't start.

When the clean light comes on, the oven starts the cleaning cycle. About 20 minutes later, the Lock Light will come on. It will stay on during the cleaning cycle. The door cannot be unlocked while the Lock Light is on.

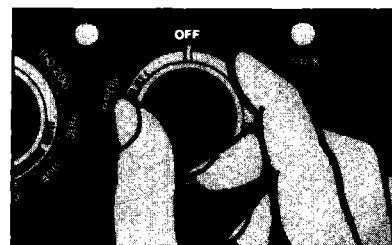

6. The oven will shut off when the preset stop time is reached, but the oven door will stay locked until the oven has cooled. When the Lock Light turns off, turn the Oven Selector Knob and Oven Temperature Control Knob to "OFF." This turns off the Clean Light. Now, move the Lock Lever back to the left. *Do not force the Lock Lever.* If it doesn't want to move easily, wait until it does. With the Lock Lever all the way to the left, the oven door can be opened.



7. When the oven has cooled off *all the way*, wipe out any residue or ashes from the bottom.

How the Self-Cleaning cycle works:

- When oven controls are set to "CLEAN," the oven gets much hotter than it does for cooking. This high heat causes soil on the inside oven walls to burn off, or break up and mostly disappear. While this is happening, a special part in the oven vent helps remove smoke. Do not cover the right-rear surface unit during the cleaning cycle.
- The chart below shows about what happens during a 2-hour Self-Cleaning cycle. Any time less than that shortens only the cleaning cycle, not the heating and cooling times.
- Don't touch the range during the cleaning cycle... it will be hot.
- When the cleaning cycle is over, you will find some fine ashes in the oven. The amount of ash depends upon the amount of soil there was in the oven. **When the oven is cool**, clean up all that is left with a damp cloth, cleanser, or a soap-filled steel-wool pad.
- During the cleaning cycle, you may hear the sounds of metal heating and cooling. These are normal sounds, and a lot like those you can hear when the oven heats for regular cooking.

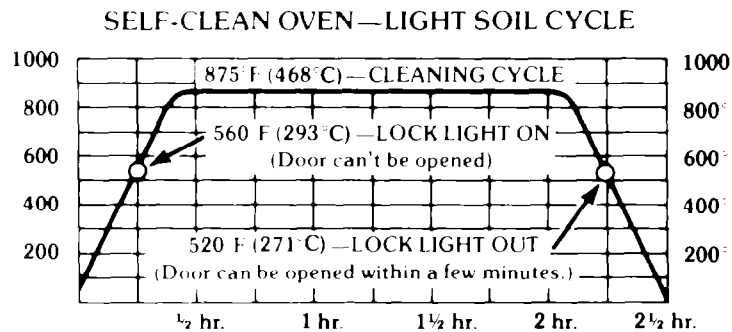

Special tips:

- If the cleaning cycle doesn't get the oven as clean as it should be, the time set for cleaning was probably not long enough. Set the cleaning time longer next time. You can set it for more than 3 hours, if you want.
- Plan to clean the oven before it gets too heavily soiled. Otherwise, you may notice more smoke than you would expect coming from the oven vent. And, the cleaning cycle has to be longer to clean a very soiled oven.
- There will be normal "heat odors" during the cleaning cycle. To help get rid of them, keep the kitchen well ventilated.
- To stop the cleaning cycle after it has started:
 - Turn the Stop Time Knob to the right time of day
 - Turn the Oven Selector Knob to "OFF"
 - Turn the Oven Temperature Control Knob to "OFF"
 - Knock and open the oven door when the Lock Light turns off.

NOTE: Do not force the Lock Lever. Wait until it moves easily.

- Do not use foil or other oven liners in your Self-Cleaning Oven.
- Don't use commercial oven cleaners in your Self-Cleaning Oven.
- If racks are left in the oven during a cleaning cycle, they will lose their shine, discolor and be harder to slide in and out. To make them slide easier, polish the edges of the racks and rack guides with a soap-filled steel wool pad, rinse well, and wipe on a thin coating of salad oil.

Cleaning and caring for your range

Your range is designed to be easy to clean. You will usually wipe off spills and spatters when they happen, but you will sometimes want to clean under and behind the control knobs and surface units. This section will tell you how to remove those, and what to use when cleaning.

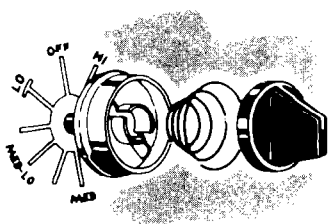

Pull knob and trim ring straight out. Remember how the spring goes.

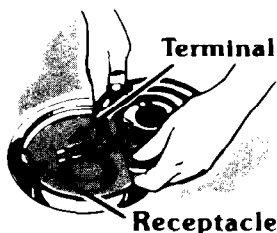

To remove surface unit, lift and pull straight out.

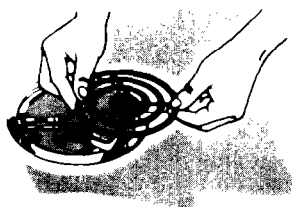

Removing and replacing surface unit control knobs:

1. Be sure the control knobs are set to "OFF"
2. Pull straight out on the black knobs
3. If the control has a chrome trim ring, pull it straight out.
4. Wash the knobs (and trim rings) in warm, sudsy water
5. Replace the trim rings first. **If the control spring was removed, put it back exactly as shown on the left...small end first.**
6. Hold the black knob so it points to "OFF". Push it straight back on.

Removing and replacing oven control knobs:

1. Be sure the knobs are set to "OFF"
2. Pull each knob straight off
3. Wash the knobs in warm, sudsy water
4. The knobs are not interchangeable. Make sure you put the **adjustable Oven Temperature Control Knob** on the right place, and the **nonadjustable Oven Selector Knob** on the other.

Removing surface units and reflector bowls:

1. First, be sure the Surface Unit Controls are all "OFF" and that the surface units are cool.
2. See where the surface units plug into the range? Lift each surface unit about an inch (2.5 cm) at the edge away from the plug-in (receptacle). Pull the unit straight away from the plug-in. **Do not wash surface units; they will burn themselves clean during normal use.**
3. Lift out the reflector bowls.

NOTE: Reflector bowls help catch spillovers and reflect heat back to the pot or pan on the surface unit. When they are kept clean, they reflect heat better and look new longer.

If a trim ring turns blue or gold, some of the pans you are using may not be flat enough. Or some may be too large for the surface unit. In both cases, some of the heat that is meant to go into or around a pan goes down and heats the reflector bowl. This extra heat can discolor the trim rings.

Do not line the reflector bowls with aluminum foil. Use of foil liners could cause shock or fire hazard.

Hold surface unit level when replacing.

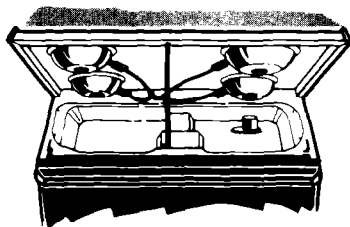
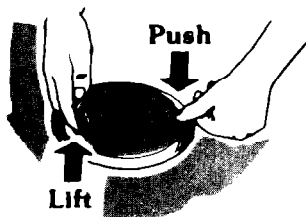

Prop up the top with support rod.

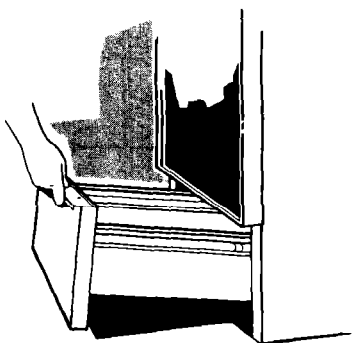

Pull to stop. Lift; pull again.

Replacing reflector bowls and surface units:

1. Be sure the surface unit controls are on "OFF."
2. Put the reflector bowls back into their places. Make sure you can see the plug-ins (receptacles) for the surface units through the square hole in the side of each bowl and trim ring.
3. Hold the surface unit level with the prongs (terminals) pointing at the plug-in.
4. With the prongs started in the plug-in, start pushing in on the surface unit. At the same time, lift a little on the side of the surface unit that's by the plug-in.
5. Make sure the surface-unit prongs are pushed into the plug-in as far as they will go. The surface unit will fit into the reflector bowl and be level when everything has been done right.

Cleaning under the cooktop:

To clean the area under the cooktop, lift the front of the cooktop at the center. Raise the swing-up rod to hold it. (Be sure the tip of the rod is in the notch in the cooktop.) Use warm soapy water and a sponge or cloth. Scouring powders or any other abrasive cleaner may harm porcelain enamel finishes and can scratch chrome.

Be careful not to raise the cooktop so high that it touches the control console. And don't drop it. Dropping the cooktop can chip or crack a hard porcelain finish, or damage side panels and surface units.

Removing the storage drawer:

The drawer below your oven is meant to store pots and pans.

Never keep anything in there that will burn or melt.

You may want to remove the drawer for cleaning under the range. Pull it straight out until it stops. Lift the front and pull some more to get it over the stop. Now slide it out until it stops again. Lift the drawer away from the range until it slips out of the guides.

To put it back, fit the side rails at the back of the drawer into both guides on the range. Push it closed while lifting the front to get past the stops.

PART	WHAT TO USE	HOW TO CLEAN
Outside of appliance	Soft cloth, warm soapy water	<ul style="list-style-type: none"> • Wipe off regularly when range is cool.
	Nylon or plastic scouring pad for stubborn spots	<ul style="list-style-type: none"> • Do not allow food containing acids (such as vinegar, tomato, lemon juice or milk) to remain on surface. Acids will remove the glossy finish. • Do not use abrasive or harsh cleansers.
Surface units	No cleaning required	<ul style="list-style-type: none"> • Spatters or spills will burn off. • Wipe off excessive spills with damp cloth when surface unit is cold. Do not place in Self-Cleaning Oven. • Do not immerse in water.
		<ul style="list-style-type: none"> • Wash, rinse and dry well. • Do not soak.
		<ul style="list-style-type: none"> • Wipe out excess spills. Wash with other cooking utensils for routine cleaning. • Place upside down on oven racks in oven during Self-Cleaning Oven cycle.
Control knobs and chrome rims	Warm, sudsy water and bristle brush	<ul style="list-style-type: none"> • Wash, rinse and dry well. • Do not soak.
Porcelain enamel reflector bowls	Automatic dishwasher or warm, soapy water	<ul style="list-style-type: none"> • Wipe out excess spills. Wash with other cooking utensils for routine cleaning.
	Self-Cleaning Oven cycle	<ul style="list-style-type: none"> • Place upside down on oven racks in oven during Self-Cleaning Oven cycle.
Chrome trim rings	Automatic dishwasher or warm, soapy water or plastic scrubbing pad	<ul style="list-style-type: none"> • Wash with other cooking utensils. • Do not place in Self-Cleaning Oven.
Porcelain broiler pan and grid	Warm, soapy water or soapy steel wool pads	<ul style="list-style-type: none"> • Wash with other cooking utensils. • Do not place in Self-Cleaning Oven.
Control panel	Warm, soapy water Commercial glass cleaner	<ul style="list-style-type: none"> • Wash, rinse and dry with soft cloth. • Follow directions provided with cleaner.
Oven racks	Self-Cleaning Oven cycle	<ul style="list-style-type: none"> • Leave in oven during Self-Cleaning cycle.
	Warm, soapy water or soapy steel wool pads	<ul style="list-style-type: none"> • Wash, rinse and dry. Use soapy steel wool pads for stubborn areas.
Oven door glass	Warm, soapy water or plastic scrubbing pad	<ul style="list-style-type: none"> • Make certain oven is cool. Wash, rinse and dry well with soft cloth.
	Commercial glass cleaner	<ul style="list-style-type: none"> • Follow directions provided with cleaner.
Self-Cleaning Oven	For areas outside Self-Cleaning area use warm, soapy water or soapy steel wool pads	<ul style="list-style-type: none"> • Clean before using Self-Cleaning cycle to prevent burn-on of soil. • Follow directions given on page 9, "Using the Self-Cleaning Oven Cycle." • Do not use commercial oven cleaners.

Do not use foil to line the bottom of your Self-Cleaning Oven.

If you need service or assistance, we suggest you follow these four steps:

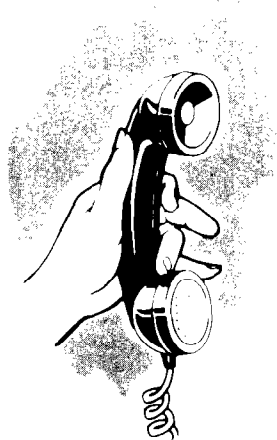

1. Before calling for assistance...

Performance problems often result from little things you can find and fix yourself without tools of any kind.

If nothing operates:

- Is the range plugged into an operating outlet or wired into a live circuit with the proper voltage? (See **Installation Instructions**.)
- Have you checked the main fuse or circuit-breaker box?

If the oven will not operate:

- Is the Oven Selector Knob turned to a setting (BAKE or BROIL, but not TIMED)?
- Is the Oven Temperature Control Knob turned to a temperature setting?

If surface units will not operate:

- Have you checked the main fuse or circuit-breaker box?
- Are surface units plugged in all the way?
- Do the control knobs turn?

If surface-unit Control Knob or Knobs will not turn:

- Is the spring put in correctly, as shown on page 12 in the "Cleaning and Caring for your Range" Section?
- Did you push in before trying to turn?

If the Self-Cleaning Cycle will not operate:

- Are the Oven Selector Knob and the Oven Temperature Control Knob set to "CLEAN"?
- Does the Start Time Knob show the correct time of day?
- Is the Stop Time Knob set ahead to the time you want the cleaning cycle to stop?
- Is the Lock Lever all the way to the right? (The Clean Light will come on.)

If cooking results aren't what you expect:

- Is the range level?
- Are you using pans recommended in the **Cooking Guide**?
- If baking, have you allowed 1½ to 2 inches (4-5 cm) on all sides of the pans for air circulation?
- Does the oven temperature seem too low or too high? See page 5, "Resetting Your Oven Temperature Control Knob."
- Have you preheated the oven as the recipe calls for?
- Are the pans the size called for in the recipe?
- Are you following a tested recipe from a reliable source?
- Do the cooking utensils have smooth, flat bottoms?
- Do the cooking utensils fit the surface unit being used?

See the **Cooking Guide** for more information on cooking problems and how to solve them.

2. If you need assistance*...

Call the Whirlpool COOL-LINE[®] service assistance telephone number. Dial free from:

Continental U.S. (800) 253-1301
 Michigan (800) 632-2243
 Alaska & Hawaii (800) 253-1121

and talk with one of our trained Consultants. The Consultant can instruct you in how to obtain satisfactory operation from your appliance or, if service is necessary, recommend a qualified service company in your area.

3. If you need service*...

Whirlpool has a nationwide network of franchised TECH-CARE[®] service companies. TECH-CARE service technicians are trained to fulfill the product warranty and provide after-warranty service, anywhere in the United States. To locate TECH-CARE service in your area, call our COOL-LINE service assistance telephone number (see Step 2) or look in your telephone directory Yellow Pages under:



APPLIANCES—HOUSEHOLD— MAJOR—SERVICE & REPAIR	OR	ELECTRICAL APPLIANCES— MAJOR—REPAIRING & PARTS	OR	WASHING MACHINES, DRYERS & IRONERS—SERVICING
WHIRLPOOL APPLIANCES FRANCHISED TECH-CARE SERVICE		WHIRLPOOL APPLIANCES FRANCHISED TECH-CARE SERVICE		WHIRLPOOL APPLIANCES FRANCHISED TECH-CARE SERVICE
<i>SERVICE COMPANIES</i>		<i>SERVICE COMPANIES</i>		<i>SERVICE COMPANIES</i>
XYZ SERVICE CO. 123 Maple		XYZ SERVICE CO. 123 Maple	999-9999	XYZ SERVICE CO. 123 Maple 999-9999

4. If you have a problem*...

Call our COOL-LINE service assistance telephone number (see Step 2) and talk with one of our Consultants, or if you prefer, write to:

Mr. Guy Turner, Vice President
 Whirlpool Corporation
 Administrative Center
 2000 US-33 North
 Benton Harbor, MI 49022

*If you must call or write, please provide: model number, serial number, date of purchase, and a complete description of the problem. This information is needed in order to better respond to your request for assistance.



FSP is a registered trademark of Whirlpool Corporation for quality parts. Look for this symbol of quality whenever you need a replacement part for your Whirlpool appliance.

FSP replacement parts will fit right and work right because they are made to the same exacting specifications used to build every new Whirlpool appliance.



Benton Harbor, Michigan. Automatic Washers, Clothes Dryers, Freezers, Refrigerator-Freezers, Ice Makers, Dishwashers, Built-in Ovens and Surface Units, Ranges, Microwave Ovens, Compactors, Room Air Conditioners, Dehumidifiers, Central Heating and Air Conditioning Systems.