



Frigidaire

Factory Parts Catalog

Product No.	FMV156DBC	FMV156DCD	FMV156DQC	FMV156DSC
Market	North America	North America	North America	North America
Color	black	stainless steel	bisque	white
Volts	120	120	120	120
Watts	950	950	950	950
Wiring Diagram	5995511242	5995511242	5995511242	5995511242
Owner's Guide	316137230	316137230	316137230	316137230
Installation Instructions	316137333	316137333	316137333	316137333



Electrolux Major Appliances
 North & Latin America
 P.O. BOX 212378
 AUGUSTA, GA 30917

Publication No.
5995511242
 08/04/07
 (EN/SERVICE/KC)
 099

**OVER-RANGE
 MICROWAVE**

Model No.
FMV156D

Copyright © 2008 Electrolux Home Products, Inc.
 All rights reserved.

OVEN, CABINET

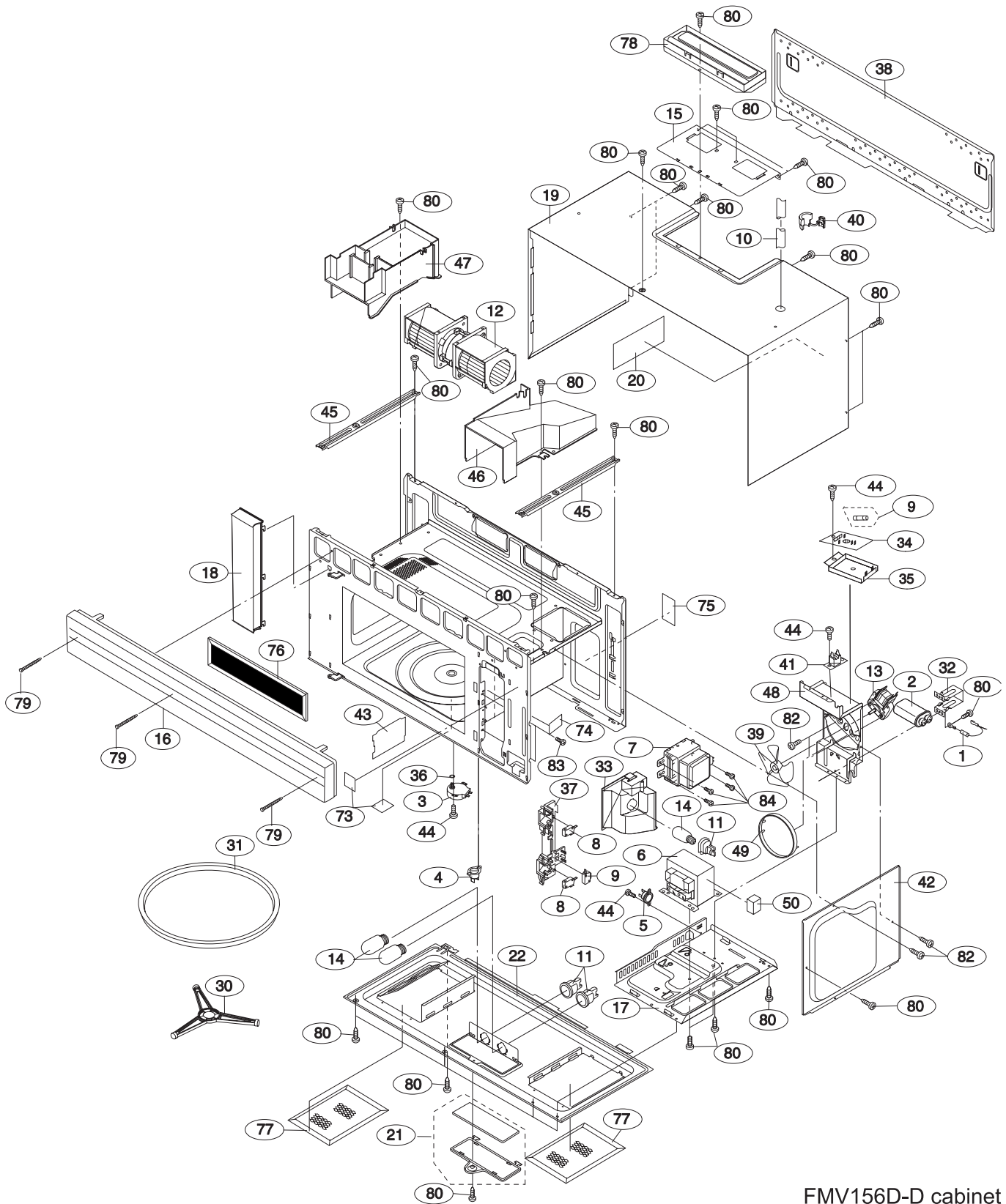

FMV156D-D cabinet

OVEN,CABINET

Model Index: A FMV156D (FMV156DBC)
 B FMV156D (FMV156DCD)
 C FMV156D (FMV156DQC)
 D FMV156D (FMV156DSC)

POS. NO	PART NO.		DESCRIPTION
1 #	5304461263	A B C D	Rectifier, high voltage
2 #	5304440342	A B C D	Capacitor, high voltage
3 #	5304448488	A B C D	Motor, turntable
4 #	5304440032	A B C D	Thermal Cutout, oven cavity
5 #	5304440023	A B C D	Thermal Cutout, hood
6 #	5304453726	A B C D	Transformer, power
7 #	5304441846	A B C D	Magnetron
8 #	5304440026	A B C D	Switch, interlock, door sensor
9 #	5303319559	A B C D	Switch, monitor, w/ceramic fuse
10 #	5304440028	A B C D	Power Cord, electric
11 #	5303319561	A B C D	Receptacle, lamp socket, oven
12 #	5304441847	A B C D	Motor, hood fan
13 #	5304441848	A B C D	Motor, cooling fan
14	5304440031	A B C D	Lamp, incandescent, 20 W, (3)
15	5304441849	A B C D	Plate, rear stay
16	5304458567	A B - -	Grille, exhaust louver, black
16	5304461265	- - C -	Grille, exhaust louver, bisque
16	5304461264	- - - D	Grille, exhaust louver, white
17	5304466700	A B C D	Base, transformer, right side
18	5304451942	A - - -	Panel, front trim, black, LS
18	5304448841	- B - -	Panel, front trim, stainless, LS
18	5304441856	- - C -	Panel, front trim, bisque, LS
18	5304441857	- - - D	Panel, front trim, white, LS
19	5304441858	A B - -	Cabinet, outer casing, black
19	5304441859	- - C -	Cabinet, outer casing, bisque
19	5304441860	- - - D	Cabinet, outer casing, white
20	5304451814	A B C D	Wiring Diagram, schematic, label
21	5303319573	A B C D	Lens/Frame Assy, lamp
22	5304451815	A B - -	Cover, unit base, black
22	5304451817	- - C -	Cover, unit base, bisque
22	5304451816	- - - D	Cover, unit base, white
30	5304440284	A B C D	Support Assy, turntable
31	5304441872	A B C D	Tray, turntable, glass
32	5304441873	A B C D	Retainer, capacitor strap
33	5304441874	A B C D	Duct, magnetron
34 #	5304451818	A B C D	Filter, noise, electronic
35	5303322975	A B C D	Bracket, noise filter, angle
36	5304440288	A B C D	Bushing, motor shaft, turntable
37	5304440289	A B C D	Latch Hook
38	5304461267	A B C D	Bracket, mounting plate, rear
39 #	5304440843	A B C D	Fan Blade, cooling fan
40	5303319605	A B C D	Bushing, grommet, power cord
41 #	5303319550	A B C D	Fuse, magnetron
42	5304441876	A B C D	Duct, hood intake, right side
43	5304440845	A B C D	Cover, waveguide
44	5304453725	A B C D	Screw, 3mm x 8mm
45	5304441877	A B C D	Support, chassis

OVEN, CABINET

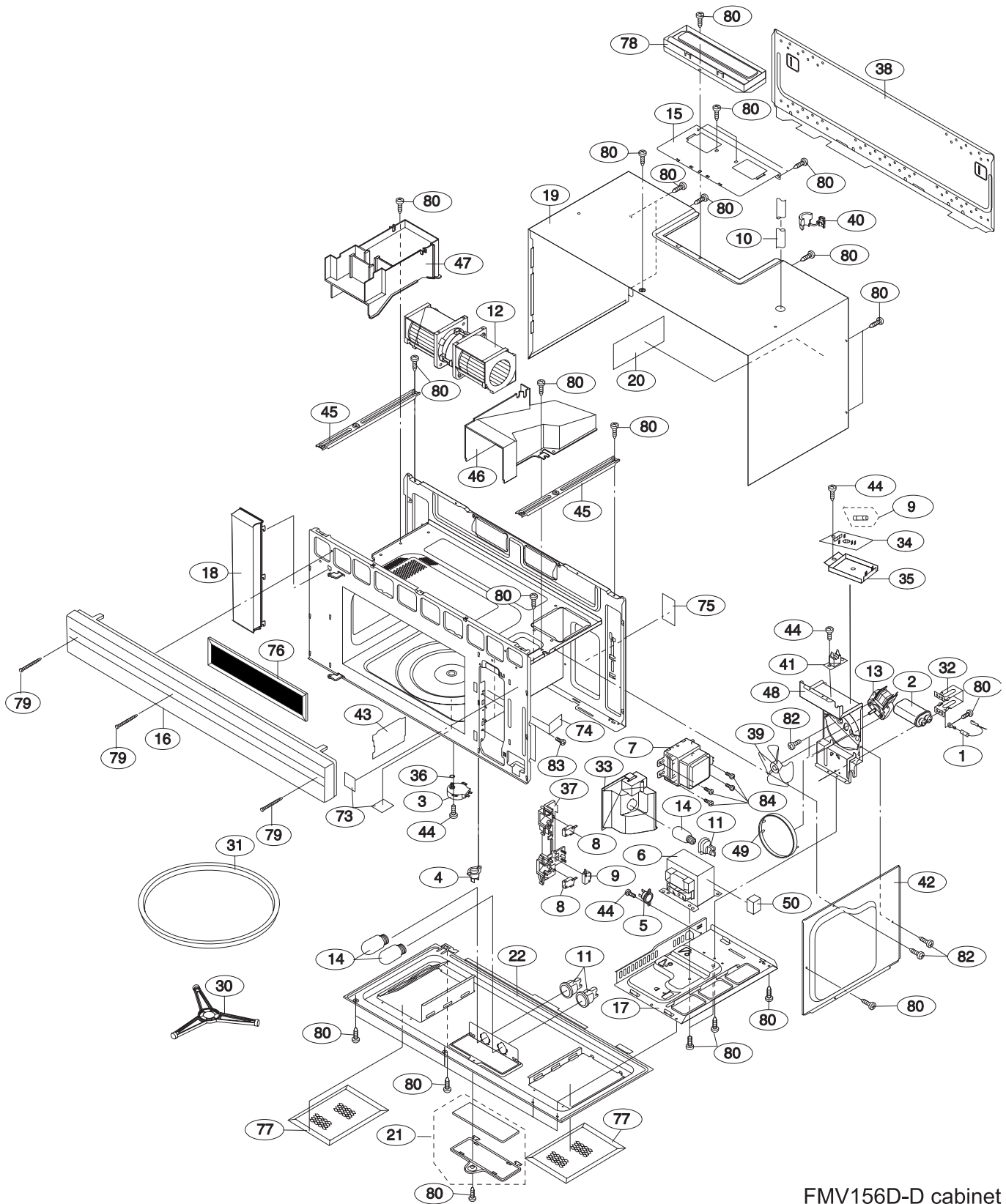

FMV156D-D cabinet

OVEN,CABINET

Model Index: A FMV156D (FMV156DBC)
 B FMV156D (FMV156DCD)
 C FMV156D (FMV156DQC)
 D FMV156D (FMV156DSC)

POS. NO	PART NO.		DESCRIPTION
46	5304441878	A B C D	Duct, hood intake, right side
47	5304441879	A B C D	Duct, exhaust hood, left side
48	5304451819	A B C D	Duct, cooling fan
49	5304441881	A B C D	Ring, fan orifice
50	5304441882	A B C D	Cushion, transformer pad
73	5304441900	A B C D	Label, Caution-DHHS
74	5304440334	A B C D	Label, Caution-monitor
75	5304440333	A B C D	Label, Caution-DHHS
76	5304456425	A B C D	Filter, inside exhaust, charcoal
77	5303319568	A B C D	Filter, grease, (2)
78	5304440283	A B C D	Damper Assy, exhaust
79	5303319640	A B - -	Screw, black
79	5303319652	- - C -	Screw, bisque
79	5303319663	- - - D	Screw, white
80	5304451553	A B C D	Screw, 4 mm x 12 mm
82	5304450253	A B C D	Screw, 4 mm x 8 mm
83	5303319641	A B C D	Screw
84	5303319636	A B C D	Screw

CONTROL PANEL,DOOR,MISC.

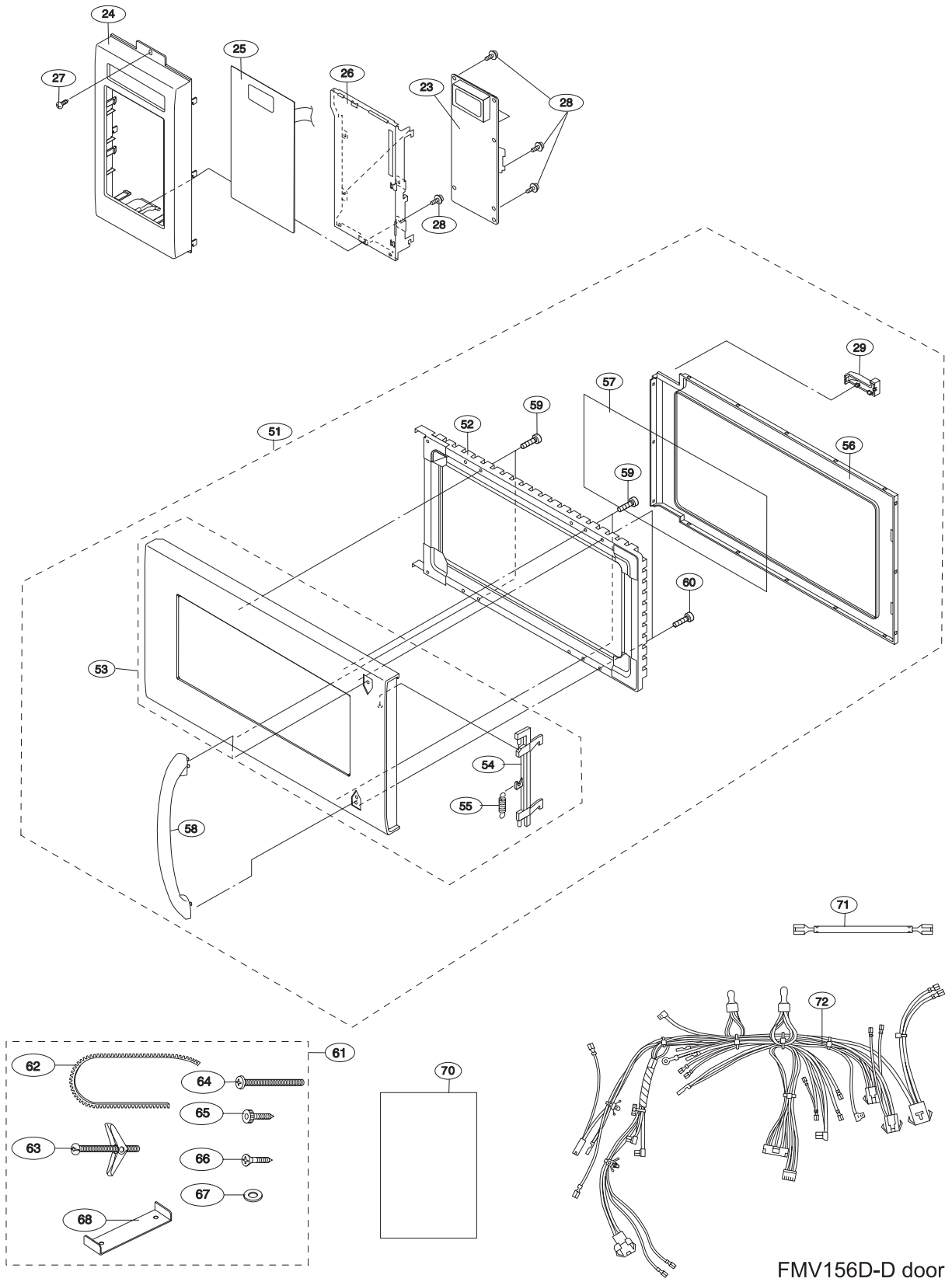

FMV156D-D door

CONTROL PANEL,DOOR,MISC.

Model Index: A FMV156D (FMV156DBC)
 B FMV156D (FMV156DCD)
 C FMV156D (FMV156DQC)
 D FMV156D (FMV156DSC)

POS. NO	PART NO.		DESCRIPTION
23 #	5304441863	A B C D	Control Board, printed circuit
24	5304450254	A - - -	Frame, control panel, black
24	5304448513	- B - -	Frame, control panel, stainless steel
24	5304441866	- - C -	Frame, control panel, bisque
24	5304441867	- - - D	Frame, control panel, white
25 #	5304441868	A B - -	Switch, touch pad, black
25 #	5304441869	- - C -	Switch, touch pad, bisque
25 #	5304441870	- - - D	Switch, touch pad, white
26	5304440281	A B C D	Panel, control mount
27	5304458568	A B C D	Screw, 3 mm x 10 mm
28	5304456930	A B C D	Screw, 3 mm x 10 mm
29	5304441871	A B C D	Door Stop
51	5304455603	A - - -	Door Assy, black, w/handle
51	5304447862	- B - -	Door Assy, stainless, w/handle
51	5304461269	- - C -	Door Assy, bisque, w/handle
51	5304461268	- - - D	Door Assy, white, w/handle
52	5304441887	A B - -	Panel, inner door, black
52	5304441888	- - C -	Panel, inner door, bisque
52	5304441889	- - - D	Panel, inner door, white
53	5304461334	A - - -	Frame, outer door, black
53		- B - -	STAINLESS FRAME NOT REPLACEABLE-ORDER STAINLESS DOOR ASSY.
53	5304461271	- - C -	Frame, outer door, bisque
53	5304461270	- - - D	Frame, outer door, white
54	5304441893	A B C D	Latch, door
55	5304440316	A B C D	Spring, door latch
56	5304441894	A B C D	Frame, choke cover, inner door
57	5304440860	A B C D	Seal, door, film
58	5304440323	A B - -	Handle, door, black
58	5304440325	- - C -	Handle, door, bisque
58	5304440324	- - - D	Handle, door, white
59	5304451561	A B C D	Screw, 4 mm x 8 mm
60	5304458213	A B C D	Screw, 4 mm x 12 mm
61	5304461272	A B C D	Hardware, installation, kit
62	5303319605	A B C D	Bushing, grommet, power cord
63	5303318762	A B C D	Screw, toggle
64	5303318764	A B C D	Screw, 5mm x 60mm
65	5304451553	A B C D	Screw, 4 mm x 12 mm
66	5304453723	A B C D	Screw, 5mm x 35mm
67	5304453724	A B C D	Washer
68	5304441896	A B C D	Bracket, scale plate
70	5304458571	A B C D	Template, installation, top/wall
71 #	5304441898	A B C D	Wire, high voltage-A
72 #	5304451820	A B C D	Wiring Harness, main

WIRING SCHEMATIC

SCHEMATIC
 NOTE: CONDITION OF OVEN
 1. DOOR CLOSED.
 2. CLOCK APPEARS ON DISPLAY.

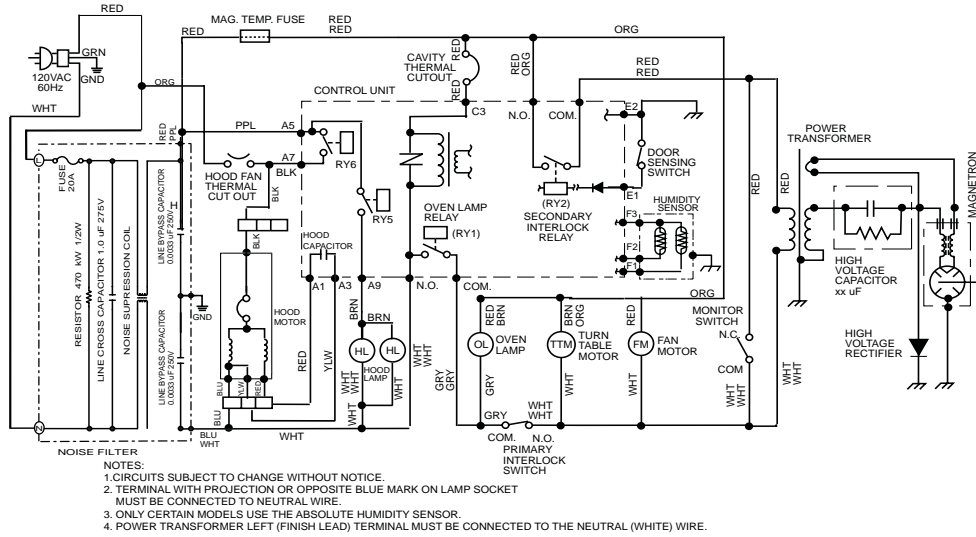

Figure O-1. Oven Schematic-Off Condition

SCHEMATIC
 NOTE: CONDITION OF OVEN
 1. DOOR CLOSED.
 2. COOKING TIME PROGRAMMED.
 3. VARIABLE COOKING CONTROL "HIGH".

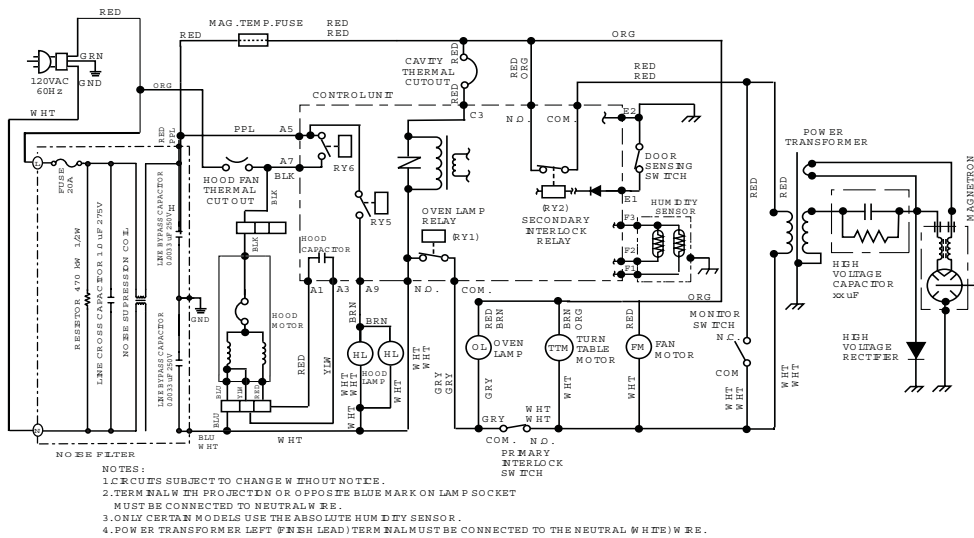

Figure O-2. Oven Schematic-Cooking Condition