

## Use & Care Guide

Side-By-Side Refrigerator

## Guía de Uso y Cuidado

Refrigerador de dos puertas

## Guide d'utilisation et d'entretien

Réfrigérateur à compartiments juxtaposés

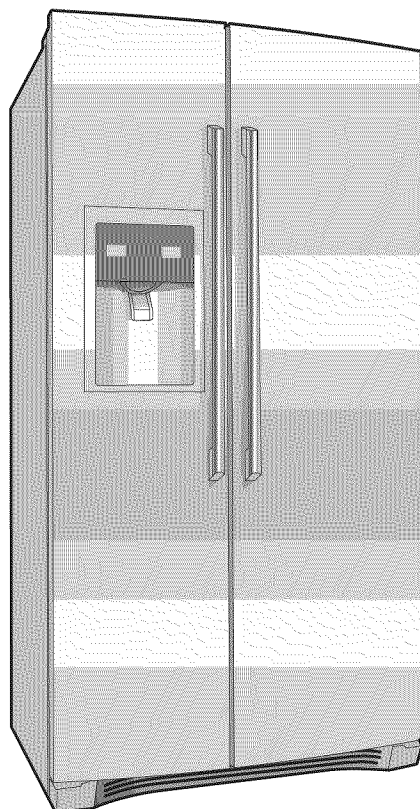

 **Electrolux**

## Please read and save this guide

---

Thank you for choosing Electrolux, our new premium brand in home appliances. This Use & Care Guide is part of our commitment to customer satisfaction and product quality throughout the service life of your new appliance.

## Keep a record for quick reference

---



---

Purchase date

---

Electrolux model number

---

Electrolux serial number



### NOTE

Registering your product with Electrolux enhances our ability to serve you. You can register online at [www.electroluxappliances.com](http://www.electroluxappliances.com) or by dropping your Product Registration Card in the mail.

## Questions?

---

For toll-free telephone support in the U.S. and Canada: 1-877-4ELECTROLUX (1-877-435-3287)

For online support and product information visit <http://www.electroluxappliances.com>

## Table of contents

---

Finding Information .....	2
Safety .....	3
Installation.....	5
Removing The Doors .....	8
Installing Door Handles .....	10
Connecting The Water Supply .....	11
Feature Overview.....	13
Controls.....	14
Storage Features .....	19
Automatic Ice & Water Maker/Dispenser .....	27
Changing The Filter .....	30
Storing Food & Saving Energy.....	32
Normal Operating Sounds & Sights .....	33
Care & Cleaning.....	34
Warranty .....	37
Before You Call.....	38

## Important safety instructions



### WARNING

Please read all safety instructions before using your new refrigerator.

### Safety Precautions

Do not attempt to install or operate your unit until you have read the safety precautions in this manual. Safety items throughout this manual are labeled with a Danger, Warning or Caution based on the risk type.

### Definitions

 This is the safety alert symbol. It is used to alert you to potential personal injury hazards. Obey all safety messages that follow this symbol to avoid possible injury or death.



### DANGER

DANGER indicates an imminently hazardous situation which, if not avoided, will result in death or serious injury.



### WARNING

WARNING indicates a potentially hazardous situation which, if not avoided, could result in death or serious injury.



### CAUTION

CAUTION indicates a potentially hazardous situation which, if not avoided, may result in minor or moderate injury.



### IMPORTANT

Indicates installation, operation or maintenance information which is important but not hazard-related.

### General Safety

- Do not store or use gasoline, or other flammable liquids, near this or any other appliance. Read product labels for warnings regarding flammability and other hazards.
- Do not operate the refrigerator in the presence of explosive fumes.
- Avoid contact with any moving parts of the automatic ice maker.
- Remove all staples from the carton to avoid cut injuries. Staples can also damage finishes if they come in contact with other appliances or furniture.

### Child Safety

#### Packing Materials:

- Packing cartons covered with rugs, bedspreads, plastic sheets or stretch wrap may become airtight chambers and can quickly cause suffocation.
- Destroy or recycle the product's carton, plastic bags, and any other exterior wrapping material immediately after the refrigerator is unpacked. Children should never play with these items.

#### Child Entrapment And Suffocation:

- These problems are not limited to the past. Whether junked, abandoned or temporarily stored (even for a few hours), unattended refrigerators and freezers are dangerous. Please take the precautions listed below.

### Proper Disposal Of Refrigerators/Freezers

We strongly encourage responsible appliance recycling/disposal methods. Check with your utility company or visit [www.energystar.gov/recycle](http://www.energystar.gov/recycle) for more information on recycling your old refrigerator.

Before you throw away your old refrigerator/freezer:

- Remove the doors.
- Leave the shelves in place so children may not easily climb inside.
- Have refrigerant removed by a qualified service technician.

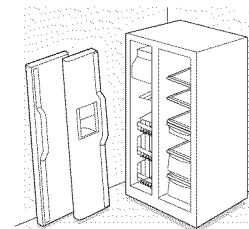

## Electrical information



### WARNING

You must follow these guidelines to ensure that your refrigerator's safety mechanisms are operating correctly.

- **The refrigerator must be plugged into its own dedicated 115 Volt, 60 Hz., AC-only electric outlet.** The power cord of the appliance is equipped with a three-prong grounding plug for your protection against electrical shock hazards. It must be plugged directly into a properly grounded three-prong receptacle. The receptacle must be installed in accordance with local codes and ordinances. Consult a qualified electrician. **Do not use an extension cord or adapter plug.**
- If the power cord is damaged, it should be replaced by the manufacturer, service technician or a qualified person to prevent any risk.
- Never unplug the refrigerator by pulling on the power cord. Always grip the plug firmly, and pull straight out from the receptacle to prevent damaging the power cord.
- Unplug the refrigerator before cleaning and before replacing a LED light to avoid electrical shock.
- Performance may be affected if the voltage varies by 10% or more. Operating the refrigerator with insufficient power can damage the compressor. Such damage is not covered under your warranty.
- Do not plug the unit into an outlet controlled by a wall switch or pull cord to prevent the refrigerator from being turned off accidentally.
- Avoid connecting refrigerator to a Ground Fault Interrupter (GFI) circuit.

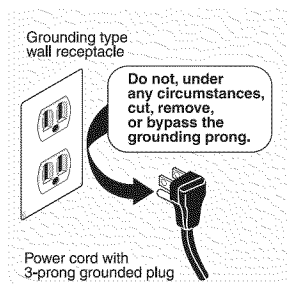

### IMPORTANT

To turn off power to your refrigerator, unplug the power cord from the wall outlet.

This Use & Care Guide provides general operating instructions for your model. Use the refrigerator only as instructed in this Use & Care Guide. **Before starting the refrigerator, follow these important first steps.**

## Location

- Choose a place that is near a grounded electrical outlet. **Do Not** use an extension cord or an adapter plug.
- If possible, place the refrigerator out of direct sunlight and away from the range, dishwasher or other heat sources.
- The refrigerator must be installed on a floor that is level and strong enough to support a fully loaded refrigerator.
- Consider water supply availability for models equipped with an automatic ice maker.



## CAUTION

**DO NOT** install the refrigerator where the temperature will drop below 55°F (13°C) or rise above 110°F (43°C). The compressor will not be able to maintain proper temperatures inside the refrigerator.

**DO NOT** block the toe grille on the lower front of your refrigerator. Sufficient air circulation is essential for the proper operation of your refrigerator.

## Installation

### Installation clearances

- Allow the following clearances for ease of installation, proper air circulation, and plumbing and electrical connections:

Sides & Top	3/8 inch
Back	1 inch



## NOTE

If your refrigerator is placed with the door hinge side against a wall, you may have to allow additional space so the door can be opened wider.

## Toe Grille Installation and Removal

### To install toe grille

- 1 Open both doors. Slide left and right sides of toe grille over lower hinges of refrigerator.
- 2 While pushing toe grille firmly against cabinet, fasten bottom clips of toe grille to cabinet.
- 3 Fasten top clips to cabinet.

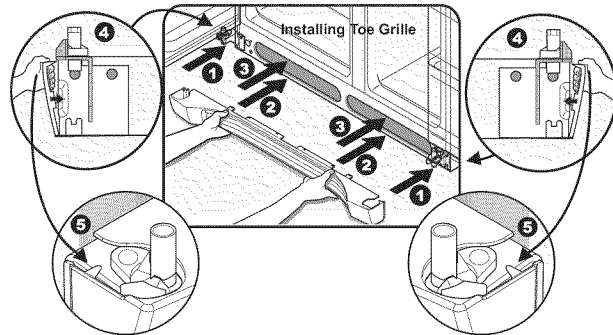

- 4 Close the doors. Fasten right and left side of clips into groove of bottom hinge by pulling outwards on the edge.

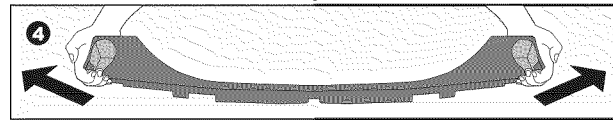

- 5 Ensure the triangle flap is resting on top of the door hinge.

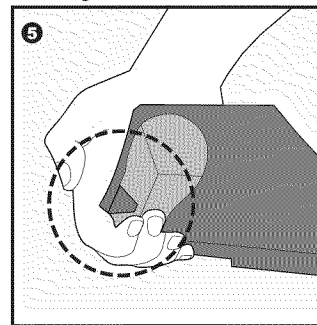

### To remove toe grille

- 1 With both doors closed, unfasten right and left side clips of toe grille from bottom hinge groove.
- 2 Open both doors. Press firmly on top of toe grille until top of toe grille pops off.
- 3 Pull toe grille outward towards your body and off of lower hinges.

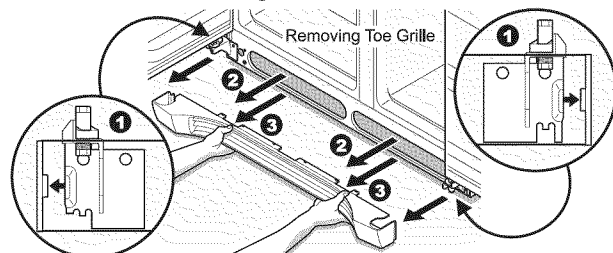

## Door opening

### NOTE

The refrigerator doors are designed to shut by themselves within a 20 degree opening.

Your refrigerator should be positioned to allow easy access to a counter when removing food. For best use of drawers and freezer baskets, the refrigerator should be in a position where both the refrigerator and freezer doors can be fully opened.

### Guidelines for final positioning of your refrigerator:

- All four corners of the cabinet must rest firmly on the floor.
- The cabinet should be level at the front and rear.
- The sides should tilt  $\frac{1}{4}$  inch (6 mm) from front to back (to ensure that doors close and seal properly).
- Doors should align with each other and be level.

**All of these conditions can be met by raising or lowering the adjustable front rollers.**

#### To level the cabinet using the front rollers:

- 1 Open both doors and remove the toe grille (see “**Toe Grille Installation and Removal**” in the “**Installation**” section).
- 2 Close the doors and use a flat-blade screwdriver or  $\frac{3}{8}$  inch socket wrench to raise or lower the front rollers.
- 3 Ensure both doors are bind-free with their seals touching the cabinet on all four sides.

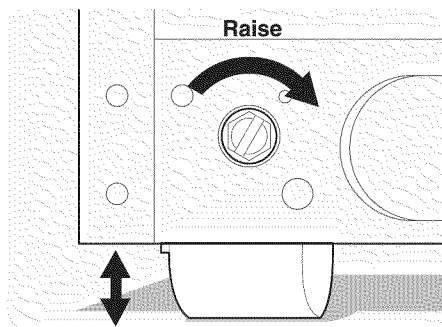

NOTE: Level the unit with the adjustable rollers before leveling the doors.

#### To level the doors using the adjustable lower hinge (some models):

- 1 Before leveling either door, remove set screw that locks door height into position. (The door cannot be adjusted without set screw removed).
- 2 If the refrigerator door is lower than the freezer door, raise the refrigerator door by turning the adjustment screw clockwise using a  $\frac{7}{16}$  inch wrench. (See illustration.)
- 3 If the freezer door is lower than the refrigerator door, raise the freezer door by turning the adjustment screw clockwise using a  $\frac{7}{16}$  inch wrench. (See illustration.)

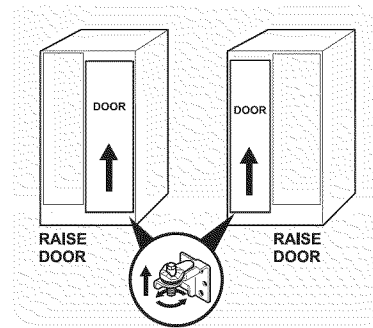

- 4 After leveling, verify door stop contacts lower hinge and top of door does not contact upper hinge through full movement of door (from fully closed to fully open).
- 5 Reinstall set screw, locking the door height.

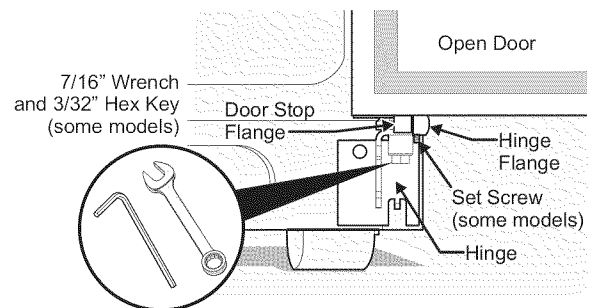

- 6 Replace the toe grille by fitting it into place (see “**Toe Grille Installation and Removal**” in the “**Installation**” section).

## Installing Shelves

Your refrigerator was shipped with the shelf hanger and shelf locking clip installed in their shipping position. Below are the instructions to install the shelves in your desired locations.

- 1 Detach clip from the back of hanger by pushing down on the top of the clip and pulling the clip towards you.

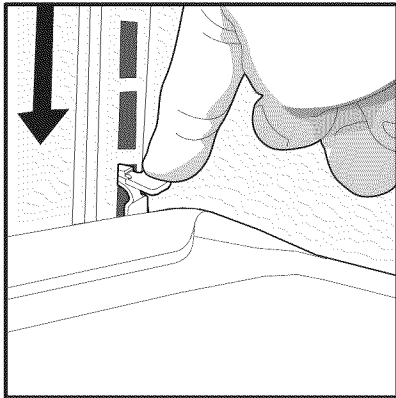

- 2 Lift the hanger directly upwards and then towards you to remove it from the ladder.

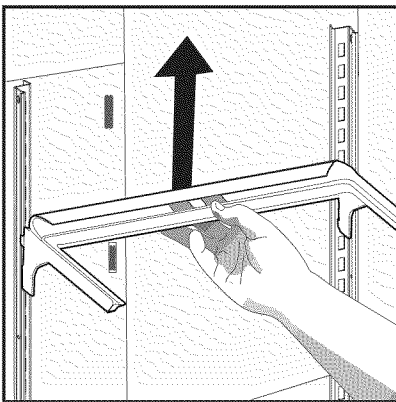

- 3 Place top hooks of the hanger into the desired slot, and lower straight down until lower hooks rest on the ladder.

### CAUTION

Shelves must be removed prior to moving the refrigerator.

### NOTE

Features may vary according to model.

- 4 Reinsert clips by positioning prongs on either side of the hanger hook and pushing down on the top of the clip until it fits into the slot.

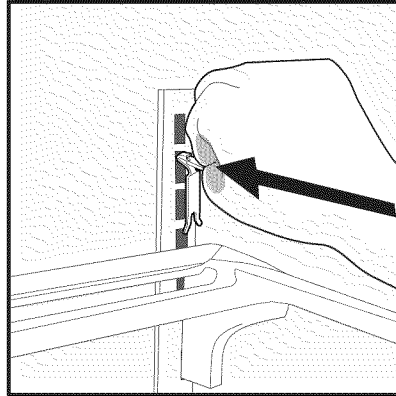

- 5 While holding shelf at a 45-degree angle with the gray handle facing you, push the shelf directing into the back of the hanger.

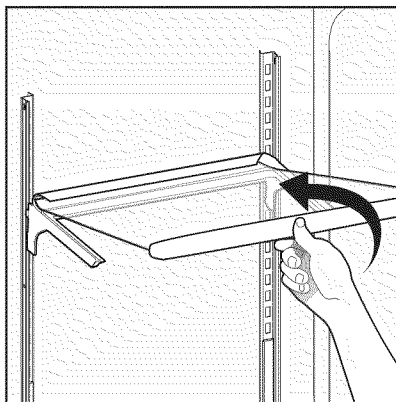

- 6 Gently set the shelf onto the hanger once the back is secured by the hanger.

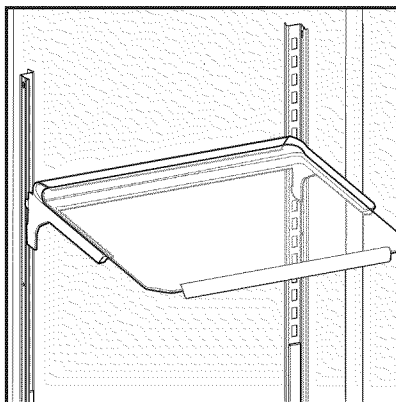

# Removing The Doors

## Getting through narrow spaces

If your refrigerator will not fit through an entrance area, you can reduce its size by removing the doors. Check first by measuring the entrance.

### Required Tools

You will need the following tools:

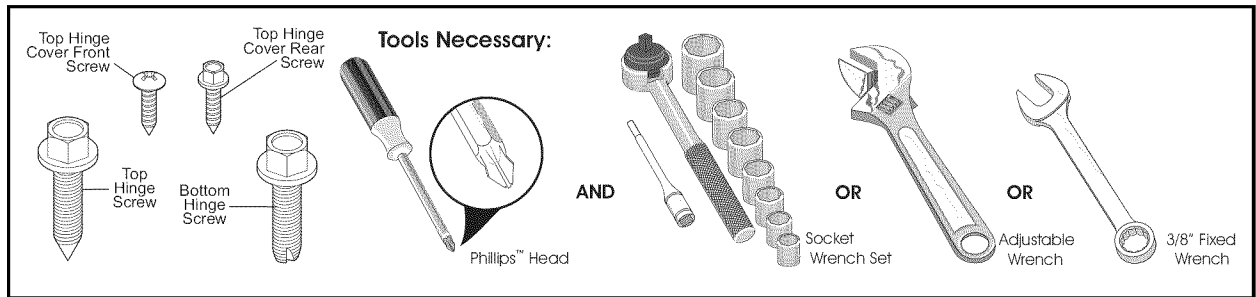

### To prepare for removing the doors:

- 1 Make sure the electrical power cord is unplugged from the wall outlet.
- 2 Open both doors and remove the toe grille (as explained in the Installation Instructions that came with your appliance).
- 3 Remove any food from the door shelves.
- 4 Close the doors.

### To remove the refrigerator top hinge cover:

- 1 Remove the three screws from each cover over the top door hinges.
- 2 Lift hinge cover straight up and off.

### To remove the refrigerator door:

- 1 Trace lightly around the door's top hinge with a pencil. This makes reinstallation easier.
- 2 Remove the two screws from the top hinge. Lift the door off of the bottom hinge and set it aside.
- 3 Remove the two bottom hinge screws and hinge if necessary.

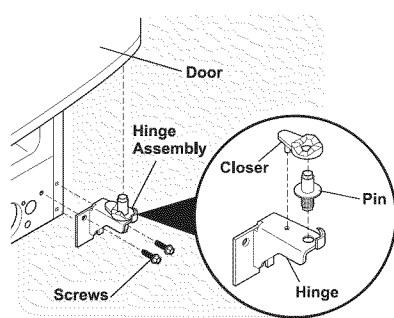

**Adjustable Hinge**  
(some models)

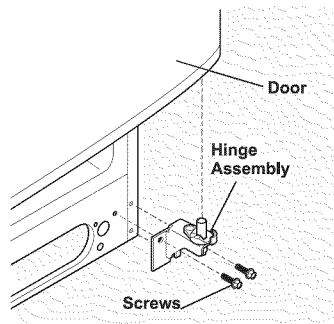

**Non-Adjusting Hinge**  
(some models)

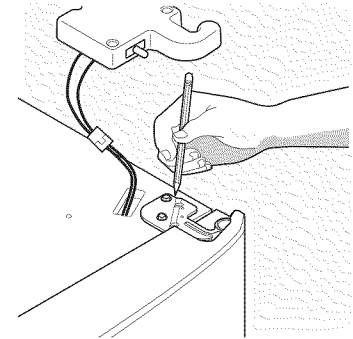
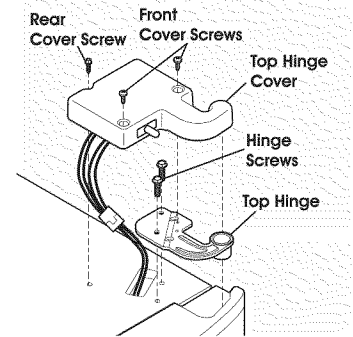

### CAUTION

Be sure doors are set aside in a secure position where they cannot fall and cause personal injury.

To reinstall the refrigerator door, reverse the above steps.



## To remove the freezer top hinge cover:

- 1 Remove the two screws from each cover over the top door hinges.
- 2 Lift hinge cover straight up and off.

## To remove the freezer door:

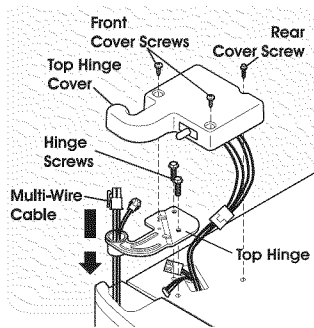

- 1 Detach the multi-wire cable connector located above the top hinge. Grasp both sides of the connector firmly and pull apart.

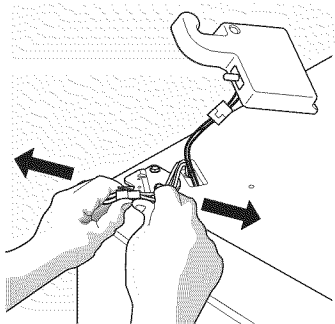

- 2 Trace lightly around the hinge with a pencil. This makes reinstallation easier.

- 3 Detach the water tube from the connector located below the freezer door. The connector releases when you press and hold its outer sleeve inward. With the sleeve held in this position, the tube can be removed.

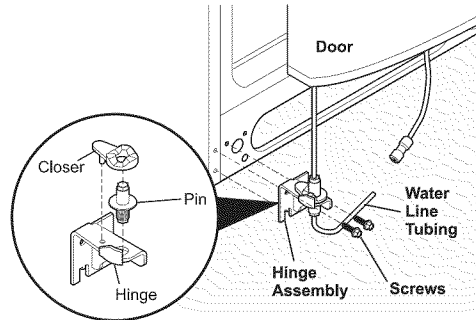

**Adjustable Hinge (some models)**

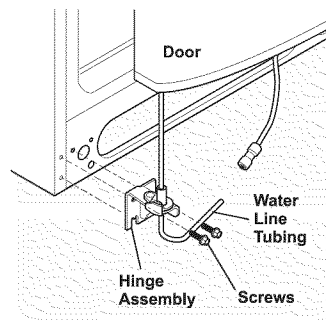

**Non-Adjusting Hinge (some models)**

- 4 Remove the screws from the top hinge and pull the multi-wire cable through it. Lift the door off of the bottom hinge.
- 5 Remove the two bottom hinge screws and hinge if necessary.
- 6 Lay the door on its side to avoid damage to the water tube extending from the bottom hinge.

To reinstall the freezer door, reverse the above steps.

Once both doors are in place, ensure they are aligned with each other and level (Please see “To level the doors using the lower hinge” for models with adjustable lower hinges or “To level the cabinet using the front rollers” for models with the non-adjustable lower hinges in the “Installation” section.), then replace the top hinge cover.

## Door Handle Mounting Instructions

- 1 Remove handles from carton and any other protective packaging.
- 2 Position freezer handle end caps over upper and lower pre-installed shoulder bolts (A) that are fastened into door, ensuring the holes for the set screws are facing towards the refrigerator door.
- 3 While holding handle firmly against door, fasten upper and lower Allen set screws (B) with supplied Allen wrench.
- 4 Repeat steps 2 and 3 to install refrigerator handle. Ensure the holes for the set screws are facing towards the freezer door.

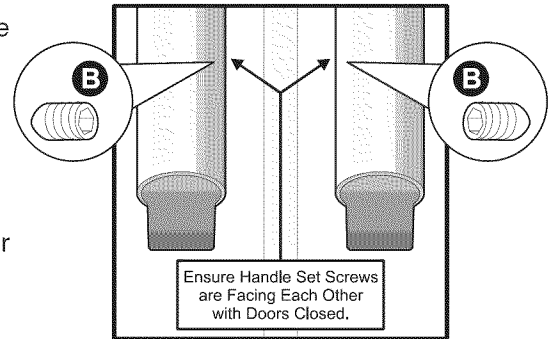

### NOTE

All set screws should be tightened and sub-flush (Allen set screw should be seated just below the surface of the end cap) of handle end cap. The end caps should be drawn tight to freezer and refrigerator doors with no gaps.

Freezer Upper End Cap

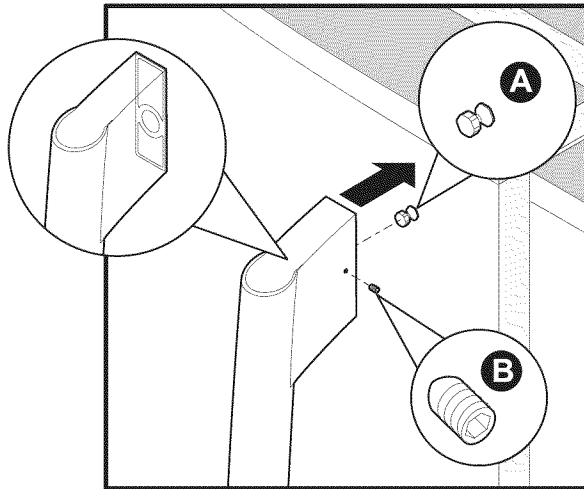

Refrigerator Upper End Cap

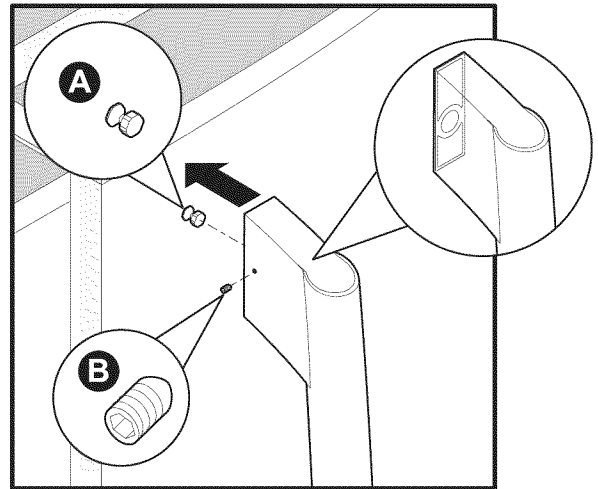

Freezer Lower End Cap

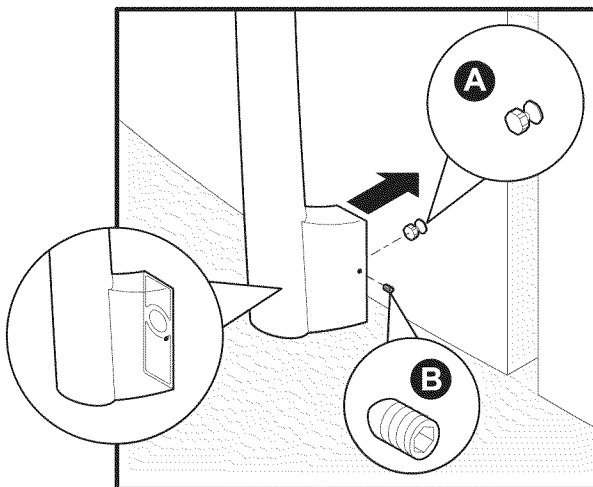

Refrigerator Lower End Cap

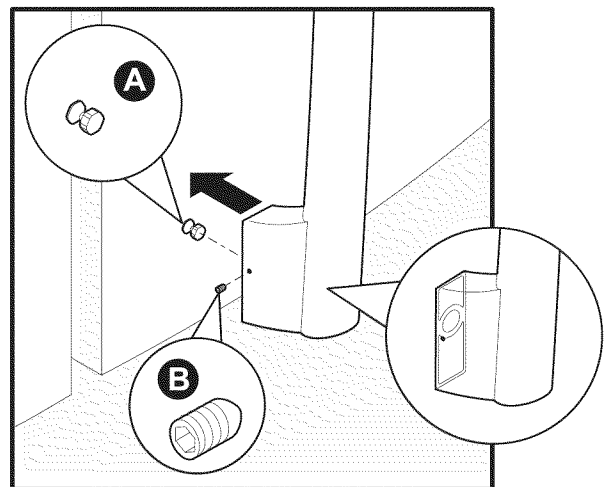



## WARNING

To avoid electric shock, which can cause death or severe personal injury, disconnect the refrigerator from electrical power before connecting a water supply line to the refrigerator.



## CAUTION

To Avoid Property Damage:

- Copper or Stainless Steel braided tubing is recommended for the water supply line. Water supply tubing made of ¼ inch plastic is not recommended to be used. Plastic tubing greatly increases the potential for water leaks, and the manufacturer will not be responsible for any damage if plastic tubing is used for the supply line.
- DO NOT install water supply tubing in areas where temperatures fall below freezing.
- Do not reuse compression fitting or use thread seal tape.
- Chemicals from a malfunctioning softener can damage the ice maker. If the ice maker is connected to soft water, ensure that the softener is maintained and working properly.



## IMPORTANT

Ensure that your water supply line connections comply with all local plumbing codes.

### *Before Installing The Water Supply Line, You Will Need:*

- Basic Tools: adjustable wrench, flat-blade screwdriver, and Phillips™ screwdriver
- Access to a household cold water line with water pressure between 30 and 100 psi.
- A water supply line made of ¼ inch (6.4mm) OD, copper or stainless steel tubing. To determine the length of tubing needed, measure the distance from the ice maker inlet valve at the back of the refrigerator to your cold water pipe. Then add approximately 7 feet (2.1 meters), so the refrigerator can be moved out for cleaning (as shown).
- A shutoff valve to connect the water supply line to your household water system. DO NOT use a self-piercing type shutoff valve.
- Do not reuse compression fitting or use thread seal tape.
- A compression nut and ferrule (sleeve) for connecting a copper water supply line to the ice maker inlet valve.



## NOTE

Check with your local building authority for recommendations on water lines and associated materials prior to installing your new refrigerator. Depending on your local/state building codes, Electrolux recommends for homes with existing valves its Smart Choice® water line kit 5305513409 (with a 6 ft. Stainless Steel Water Line) and for homes without an existing valve, Electrolux recommends its Smart Choice water® line kit 5305510264 (with a 20 ft. Copper Water Line with self-tapping saddle valve). Please refer to [www.electroluxappliances.com](http://www.electroluxappliances.com) for more information.

### *To Connect Water Supply Line To Ice Maker Inlet Valve*

1. Disconnect refrigerator from electric power source.
2. Place end of water supply line into sink or bucket. Turn ON water supply and flush supply line until water is clear. Turn OFF water supply at shutoff valve.
3. Remove plastic cap from water valve inlet and discard cap.
4. **If you use copper tubing** - Slide brass compression nut, then ferrule (sleeve) onto water supply line. Push water supply line into water valve inlet as far as it will go (¼ inch/6.4 mm). Slide ferrule (sleeve) into valve inlet and finger tighten compression nut onto valve. Tighten another half turn with a wrench; DO NOT over tighten. See Figure 1.
5. **If you use stainless steel tubing** - The nut and ferrule are already assembled on the tubing. Slide compression nut onto valve inlet and finger tighten compression nut onto valve. Tighten another half turn with a wrench; DO NOT over tighten. See Figure 2.
5. With steel clamp and screw, secure water supply line (copper tubing only) to rear panel of refrigerator as shown.
6. Coil excess water supply line (copper tubing only), about 2½ turns, behind refrigerator as shown and arrange coils so they do not vibrate or wear against any other surface.
7. Turn ON water supply at shutoff valve and tighten any connections that leak.
8. Reconnect refrigerator to electrical power source.
9. To turn ice maker on, lower wire signal arm (side mounted) or set the ice maker's On/Off power switch to the "I" position (rear mounted).
10. Test system before use. Check for leaks again after 24 hours.

# Connecting The Water Supply

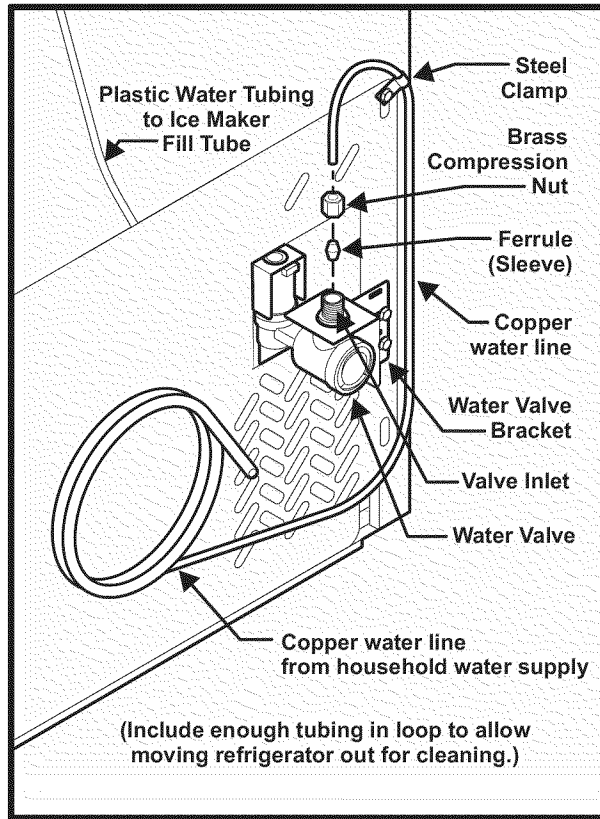

Figure 1

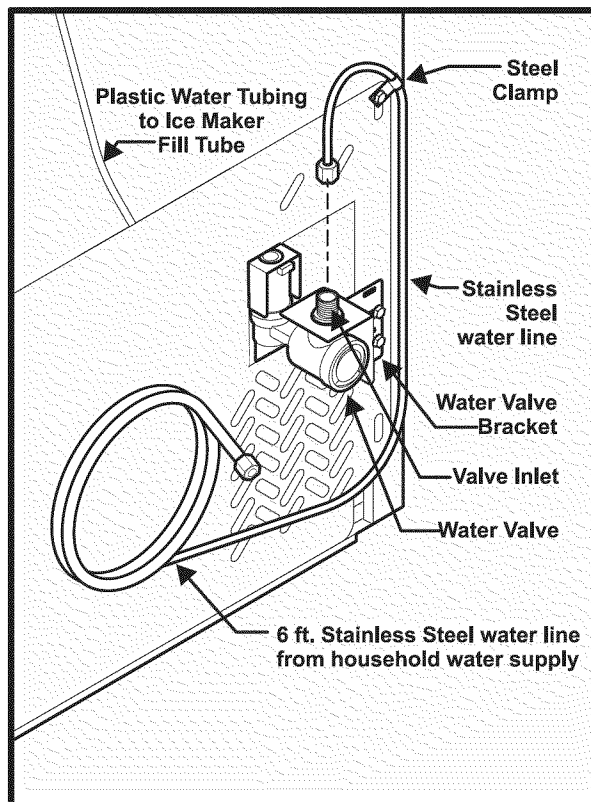

Figure 2

## ➔ IMPORTANT

After connecting the water supply, refer to "How to Prime the Water Supply System" for important information about priming an empty water supply system.

Your refrigerator's water supply system includes several tubing lines, a water filter, a water valve, and a water tank. To ensure that your water dispenser works properly, this system must be completely filled with water when your refrigerator is first connected to the household water supply line.

## Understanding features and terms

Your Electrolux refrigerator is designed for optimal convenience and storage flexibility. Use the illustration below to familiarize yourself with product features and terminology.

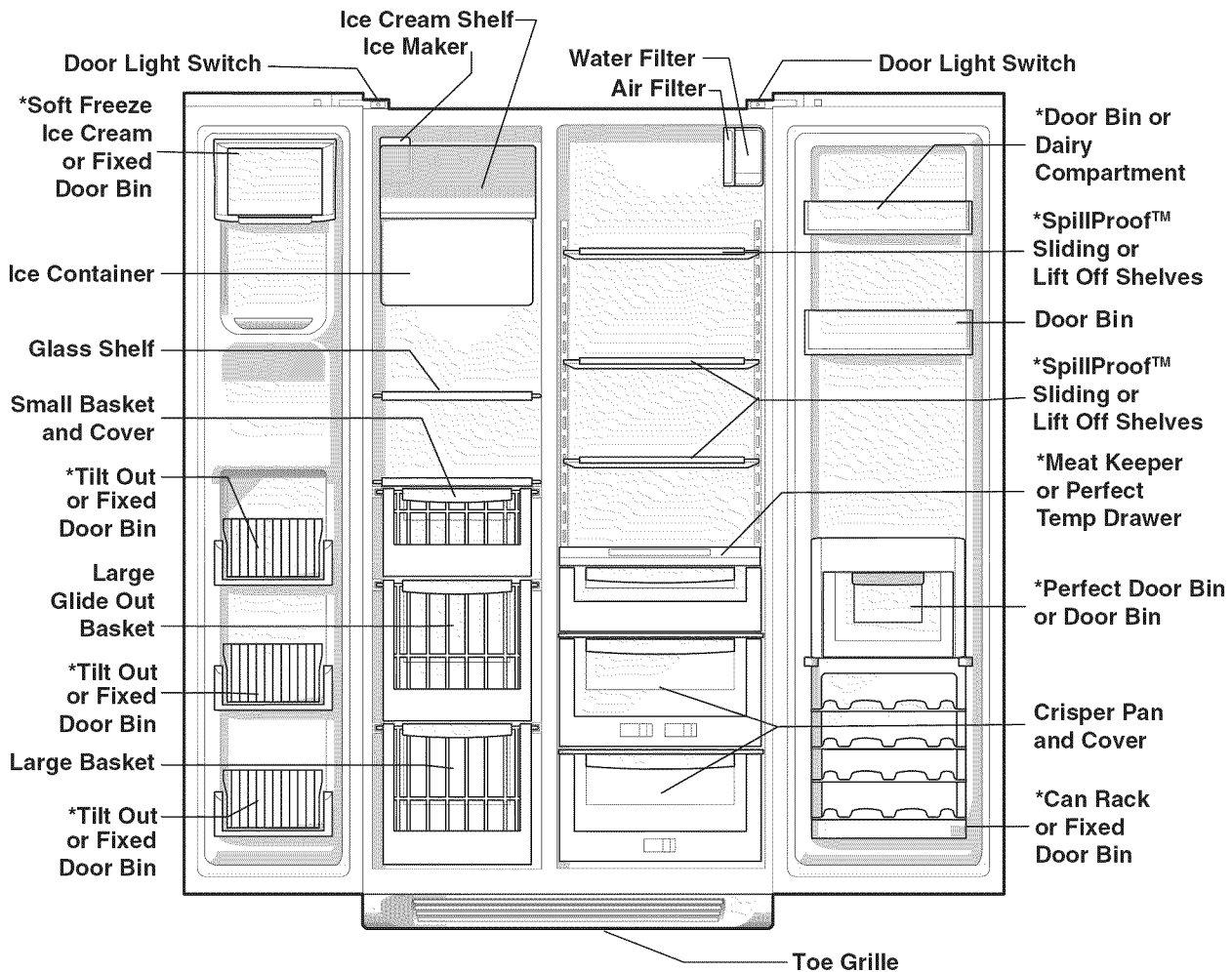

### NOTE

\*Features may vary according to model.

### IMPORTANT

Features not included with your refrigerator can be purchased at [www.electroluxappliances.com](http://www.electroluxappliances.com) or by calling 1-877-435-3287.

Wave-Touch™

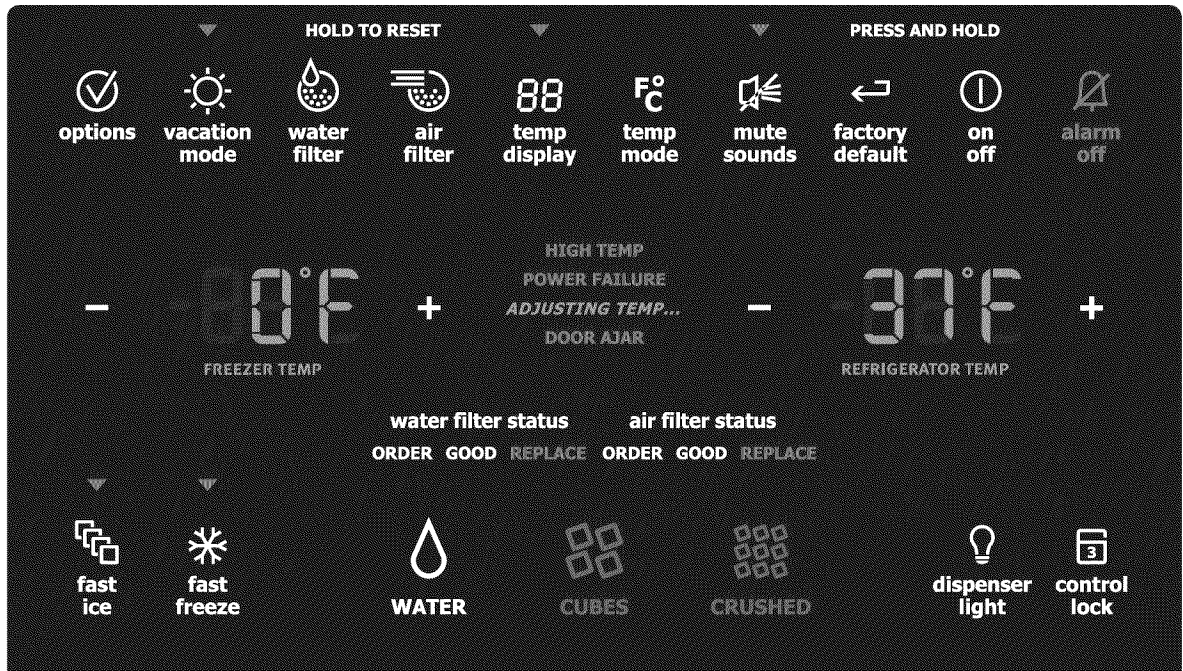

IQ-Touch™

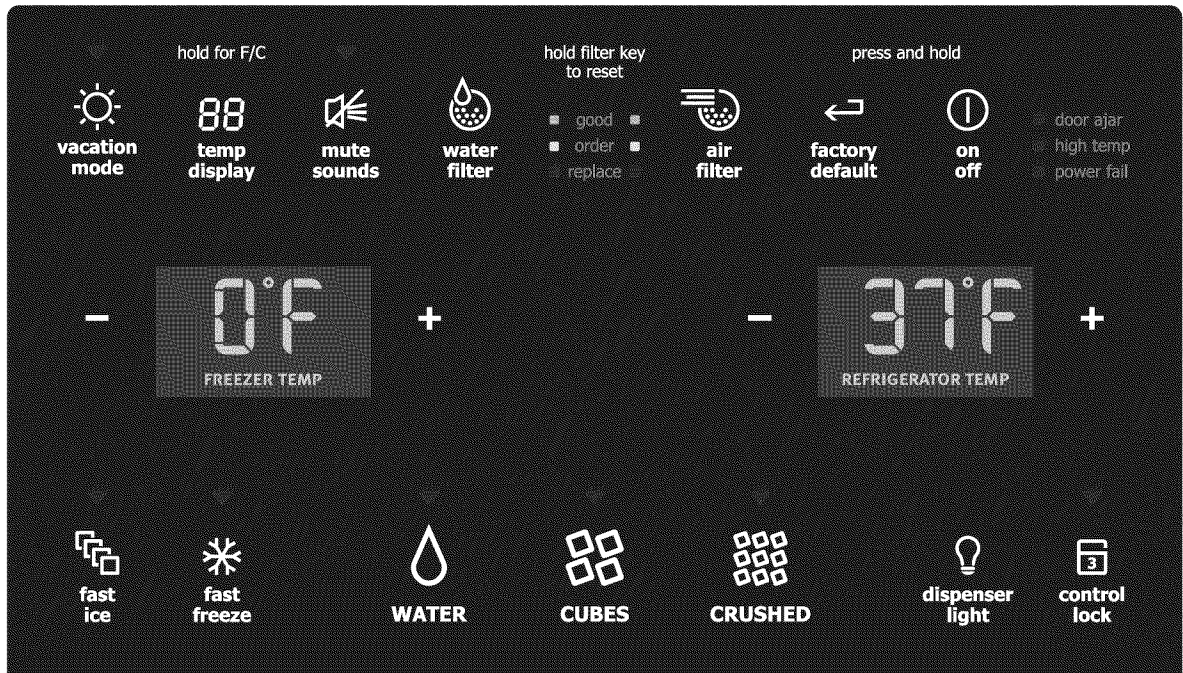

## Wave-Touch™ (some models)

Your refrigerator is equipped with a **Wave-Touch™ Panel** user interface display. It is only necessary to touch the panel. There is no need to press with force. There are three levels of display.

### 1<sup>st</sup> Level: Sleep Mode

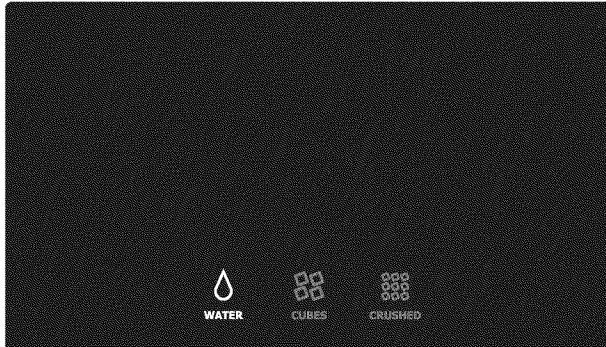

Sleep mode displays only the **WATER**, **CUBES** and **CRUSHED** options. Touch an icon to activate the desired dispenser mode. The active dispenser mode is more brightly illuminated.

### 2<sup>nd</sup> Level: Awakened Display Mode

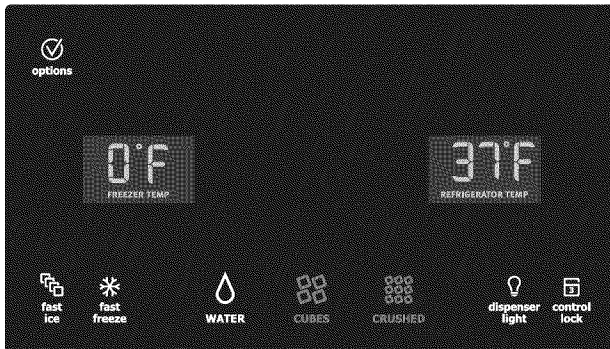

The display is awakened by touching anywhere on the panel where there is an indicator. Black space will not awaken the display. After 10 seconds of inactivity, the display will return to the Sleep mode.

The following dispenser options are illuminated:

- fast ice** Increases the production of ice
- fast freeze** Activates a faster rate for freezing food
- dispenser light** On / Off
- control lock** Press and hold for three seconds to activate and deactivate. This restricts undesired changes to the refrigerators settings and prevents use of the ice and water dispenser.

### 3<sup>rd</sup> Level: User Variable Options



Touching the options icon displays the following options:

- vacation mode** Conserves energy by increasing the time between automatic defrost. This feature is automatically activated during long periods between door openings. Vacation mode is manually activated when the red indicator is lit.
- water filter** Touch to display filter condition status. Press and hold for three seconds to reset.
- air filter** Touch to display filter status. Press and hold for three seconds to reset.
- temp display** When active, it allows the display of the freezer and refrigerator temps during "Sleep Mode". The temperature is displayed when the red indicator is lit.
- temp mode** Touch to toggle display from Fahrenheit to Celsius.
- mute sounds** Tones emitted by each keypress can be turned off based on user preference. The sounds are muted when the red indicator is lit. Warning signals will stay active.
- factory default** Resets all refrigerator settings such as temp, temp display, and alarm tones to their factory default settings.
- on off** Press and hold for three seconds to turn off the cooling system to clean the refrigerator. It also turns off all dispenser functions. The temperature display will read OFF.



### IMPORTANT

Pressing the **system off** icon does not turn off power to your refrigerator. You must unplug the power cord from the wall outlet.

### Setting cooling temperatures

- 1 Touch the panel to illuminate the 2<sup>nd</sup> level of display.
- 2 Select the options icon. Plus (+) and minus (-)

(-) indicators will appear on either side of the displayed temperatures.

- 3 Press the + or – indicator to adjust the temperature to the desired setting.

The temperature display will begin to blink with the first touch. After five seconds of inactivity, the display will beep to accept the new temperature. After 10 seconds, the display times out and returns to the basic display.

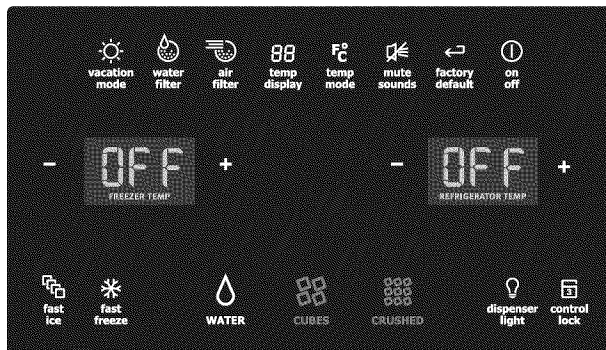

## Alarms

### Door Ajar

If the door has been left open for an extended period of time, an alarm will sound and the door ajar indicator will display in the middle. The alarm is turned off by closing the door. The **alarm off** key will illuminate to prompt the reset of any pending alarms. Press this key to reset any system Alarms.

### High Temp

In the event of a high temperature condition, the temperature display will display "HI". After 20 minutes, the **high temp** alert will be displayed and the **alarm off** icon will illuminate until pressed, acknowledging the alarm, at which time the highest temperature reached will be displayed and the refrigerator will resume normal operation. All other modes are turned off until the alarm is acknowledged.

### Power Fail

In the event of a power failure, the **power fail** alert will be displayed and the **alarm off** key will be illuminated and you will hear an audible alarm until the **alarm off** icon is pressed, acknowledging the alarm. Other modes may be turned off until the alarm is acknowledged. When the **power fail** alert is turned off, the refrigerator will resume normal operation. **The high temp alarm may also be illuminated until a safe operating range temperature has been reached.**

## Wave-Touch™/IQ-Touch™ “Sabbath Mode” (some models)

The Sabbath Mode is a feature that disables portions of the refrigerator and its controls for both Wave-Touch™ and IQ-Touch™, in accordance with observance of the weekly Sabbath and religious holidays within the Orthodox Jewish community.

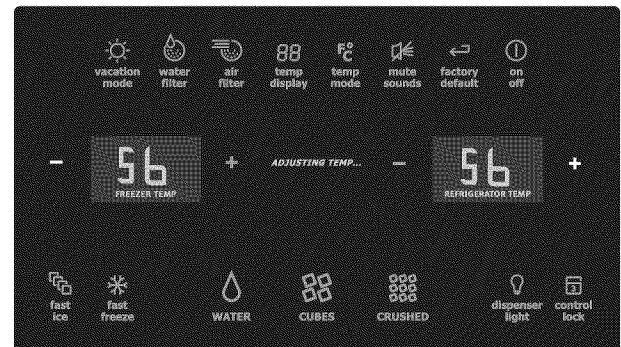

Sabbath Mode is turned ON and OFF by pressing and holding both the freezer “-” and the refrigerator “+” indicators for five seconds for both the Wave-Touch™ and IQ-Touch™ modes. The display shows “Sb” while in Sabbath mode.

In the Sabbath Mode, the High Temp alarm is active for health reasons. If a high temperature alarm is activated during this time, for example due to a door left ajar, the alarm will sound intermittently for about 10 minutes. The alarm will then silence on its own and a red high temperature icon will display. The high temp icon will continue to display, even if the door is closed, until the Sabbath mode is exited and the icon reset. The refrigerator will function normally once the door is closed, without any violation of the Sabbath/Holidays.



For further assistance, guidelines for proper usage and a complete list of models with the Sabbath feature, please visit the web at <http://www.star-k.org>.



## NOTE

Although you have entered the Sabbath mode, the ice maker will complete the cycle it had already initiated. The ice cube compartment will remain cold and new ice cubes can be made with standard trays.



## IQ-Touch™ (some models)

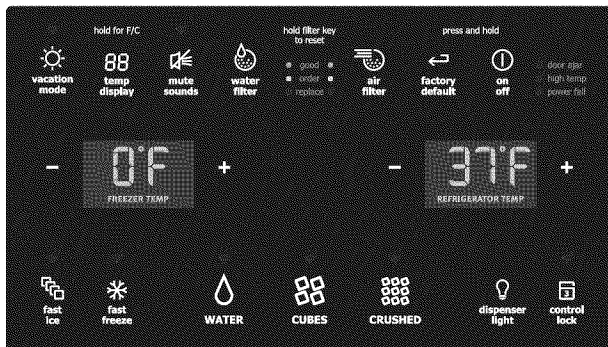

Your refrigerator is equipped with a **IQ Touch Panel** user interface display. It is only necessary to touch the panel. There is no need to press with force.

There are three dispenser modes:

- 1 Water
- 2 Ice Cubes
- 3 Crushed Ice

A red indicator light will be illuminated above the active mode.

Touch the icon to activate the options below.

Any of the following options that are activated have a red indicator light above the icon.

<b>fast ice</b>	Increases the production of ice
<b>fast freeze</b>	Activates a faster rate for freezing food
<b>dispenser light</b>	On / Off
<b>control lock</b>	Press and hold for three seconds to activate and deactivate. This restricts undesired changes to the refrigerators settings and prevents use of the ice and water dispenser.
<b>vacation mode</b>	Conserves energy by increasing the time between automatic defrost. This feature is automatically activated during long periods between door openings. Vacation mode is manually activated when the red indicator is lit.
<b>water filter</b>	Touch to display filter condition status. Press and hold for three seconds to reset.
<b>air filter</b>	Touch to display filter status. Press and hold for three seconds to reset.
<b>temp display</b>	Touch to toggle the freezer and refrigerator temps display on and off. Touch and hold <b>temp display</b> to toggle display from Fahrenheit to Celsius.
<b>mute sounds</b>	Tones emitted by each keypress can be turned off based on user preference. The sounds are muted when the red indicator is lit. Warning signals will stay active.

### factory default

Resets all refrigerator settings such as temp, temp display and ring tones to their factory default settings.

### on off

Press and hold for three seconds to turn off the cooling system to clean the refrigerator. It also turns off all dispenser functions. The temperature display will read OFF.

## → IMPORTANT

Pressing the **system off** icon does not turn off power to your refrigerator. You must unplug the power cord from the wall outlet.

## Setting cooling temperatures

- 1 Touch the panel to illuminate the display to the Plus (+) and minus (-) indicators which appear on either side of the displayed temperatures.
- 2 Press the + or – indicator to adjust the temperature to the desired setting.

The temperature display will begin to blink with the first touch. The display times out after 5 seconds and returns to the basic display.

## Alarms

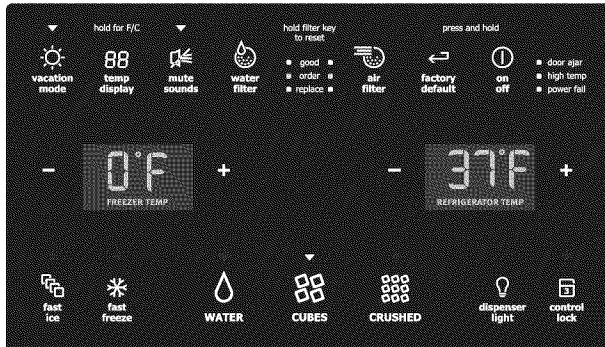

## Door Ajar

If the door has been left open for an extended period of time, an alarm will sound and the door ajar indicator will display on the right side of the display. The alarm is turned off by closing the door. The mute sounds key will illuminate to prompt the reset of any pending alarms. Press this key to reset any system alarms.

## High Temp

In the event of a high temperature condition, the temperature display will display "HI". After 20 minutes, the **high temp** alert will be displayed and the **mute sounds** icon will illuminate until pressed, acknowledging the alarm, at which time the highest temperature reached will be displayed and the refrigerator will resume normal operation. All other modes are turned off until the alarm is acknowledged.

## Power Fail

In the event of a power failure, the **power fail** alert will be displayed and the mute sounds icon will be illuminated and you will hear an audible alarm until the **mute sounds** icon is pressed, acknowledging the alarm. Other modes may be turned off until the alarm is acknowledged. When the **power fail** alert is turned off the refrigerator will resume normal operation. **The high temp alarm may also be illuminated until a safe operating range temperature has been reached.**

## Shelf features

### CAUTION

To avoid injury from breakage, handle tempered glass shelves carefully.

### NOTE

Features may vary according to model.

#### To change the position of a shelf:

- 1 Remove all items from shelf, then separate shelf from hanger by lifting the front of the glass and pulling directly towards you.
- 2 Detach clip from the back of hanger by pushing down on the top of the clip and pulling the clip towards you.

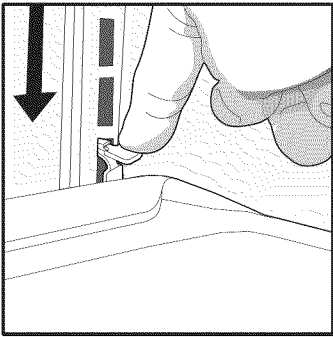

- 3 Lift the front of the glass shelf to a 45-degree angle and slide the glass shelf toward you.

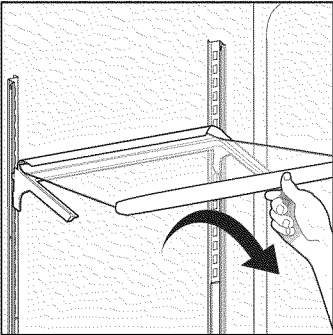

- 4 Lift the hanger directly upwards and then towards you to remove it from the ladder.

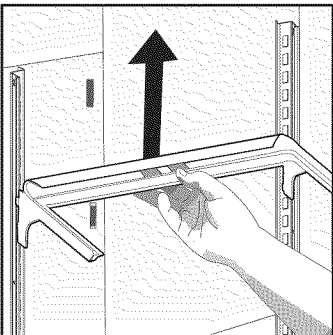

- 5 Place top hooks of the hanger into the desired slot, and lower straight down until lower hooks rest on the ladder.
- 6 Reinsert clips by positioning prongs on either side of the hanger hook and pushing down on the top of the clip until it fits into the slot.

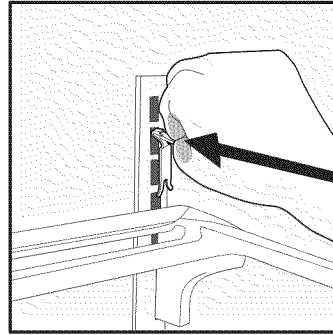

- 7 Reinsert the glass shelf by pushing it into the hanger bracket at a 45-degree angle.

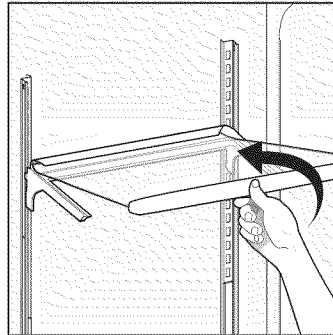

- 8 Gently set the shelf onto the hanger once the back is secured by the hanger.

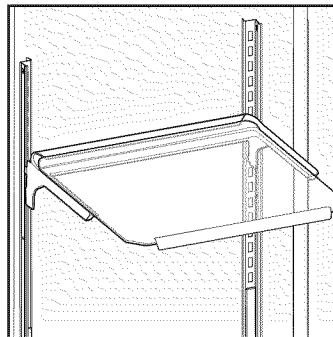

- 9 You are now ready to set items on the shelf

### CAUTION

Shelves must be removed prior to moving the refrigerator.

## Shelf features (some models)

Your refrigerator includes Luxury-Design™ glass shelves, which are designed to catch and hold accidental spills.

### CAUTION

To avoid injury from breakage, handle tempered glass shelves carefully.

### NOTE

Features may vary according to model.

You can easily adjust shelf positions in the fresh food compartments to suit your needs. The shelves have mounting brackets which attach to slotted supports at the rear of each compartment. The glass can be easily removed for cleaning.

## To change the position of a shelf (some models):

- 1 Lift the front edge up.
- 2 Slide shelf out.

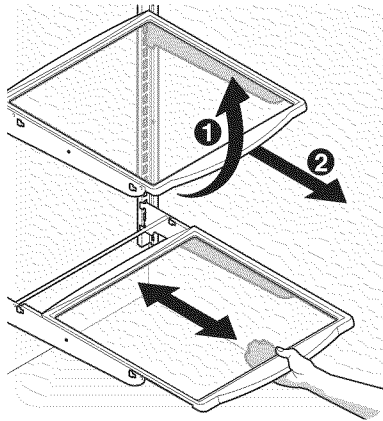

### NOTE

Some Cantilever Sliding Glass Shelves have spacers (side screws) on the sides of the brackets to securely hold the shelves in place.

To relocate the shelf to a different location, the spacers must be turned in (clockwise). To secure the shelf in a new location, remember to turn the spacers out (counterclockwise) until they touch the sides of the compartment. These shelves slide out for easy access to food and faster cleaning.

Sliding shelves can be pulled forward as far as their built-in stops allow. Sliding shelves cannot be separated from their mounting brackets.

## Drawers

Your refrigerator includes a variety of storage drawers. These drawers usually are located in fixed positions at the bottom of the fresh food compartment. Some models are supplied with soft close slides which close by themselves the last 1½ inches of travel.

## Crispers

Crisper drawers are designed for storing fruits, vegetables, and other fresh produce. Before storing items in a crisper:

- Wash items in clear water and remove excess water.
- Wrap any items that have strong odors or high moisture content.

### NOTE

Leafy vegetables keep best when stored with the Humidity Control set on Higher Humidity, or in a drawer without a Humidity Control. This keeps incoming air to a minimum and maintains maximum moisture content.

### To remove the Crisper Drawer:

- 1 Using your thumb, press down on the plastic tab (some models).
- 2 While holding down the plastic tab, lift front slightly and pull drawer up and out.

### NOTE

If there are no plastic tabs on your model, just lift front of drawer and pull up and out.

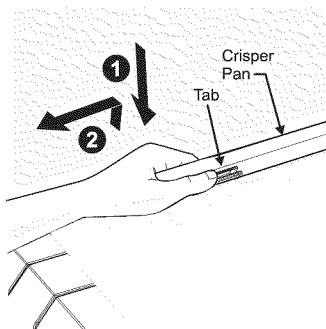

## Crisper humidity control

Crisper drawers include a sliding control for adjusting the humidity inside the crisper. This feature can extend the life of certain fresh vegetables that keep longer in high humidity.

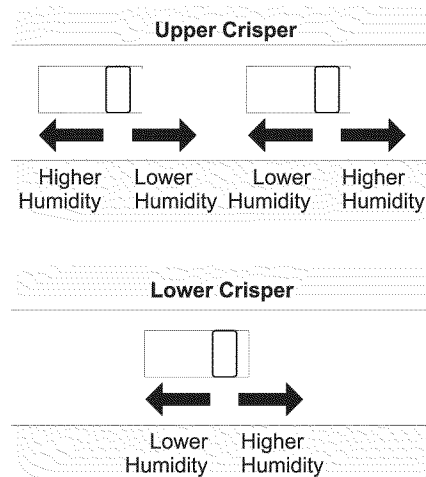

## Meat keeper (some models)

Some models are equipped with a meat keeper drawer for short-term storage of bulk meat items. This drawer includes a sliding control for adjusting the temperature inside.

Any meat to be kept longer than two days should be frozen. If you store fruits or vegetables in this drawer, set it to a warmer temperature to prevent freezing.

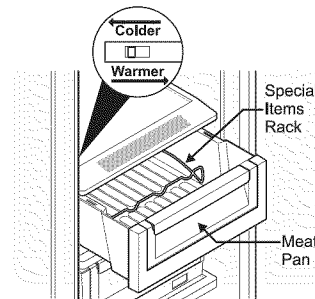

## Special items rack (some models)

The innovative design of the special items rack allows you to store four bottles of wine or soft drink bottles.

## Perfect Temp Drawer (some models)

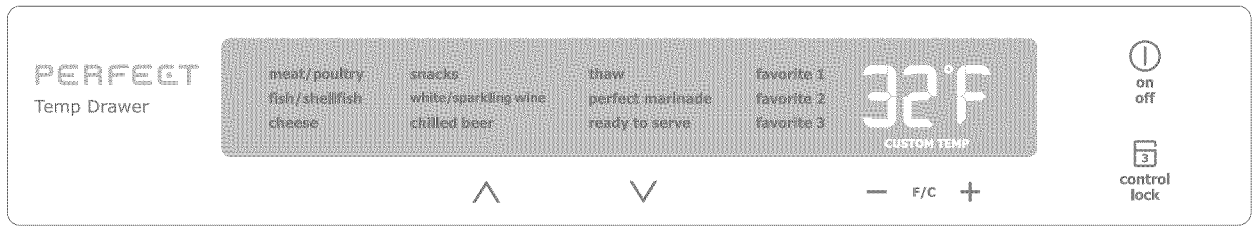

The Perfect Temp Drawer (PTD) was designed to keep food items at a precise temperature that is cooler, the same, or warmer than the fresh food side of the refrigerator.

The PTD is shipped turned OFF. When first turned on or after a power outage the PTD may show “HI°F” if it is set to a temperature before the freezer and fresh food temperatures have stabilized. To avoid this message, leave the PTD in the “OFF” setting until the freezer and fresh food compartment temperatures have stabilized.

To operate:

- 1 Turn the drawer on by pressing the **On/Off** button. The numeric display will show a temperature like “32°F” when on and “OFF” when off.
- 2 Select if Fahrenheit “F” or Celsius “C” temperature display is desired by pressing the **F/C** button.
- 3 Press either the up  $\wedge$  or down  $\vee$  scroll buttons to illuminate the desired item.
- 4 The drawer will begin controlling to the temperature shown for the item selected.
- 5 One of the three favorite selections can be chosen by illuminating it. The temperature can then be adjusted up by pressing the + button or down by pressing the – button. The drawer will store the selected temperature setting until it is changed. Three favorite settings can be chosen and stored in this way.
- 6 A custom temp between 28°F and 42°F can be set by pressing the - or + buttons while in one of the nine preset positions. The “custom temp” indicator will illuminate in this mode.
- 7 The control buttons can be locked to prevent accidental changes by pressing the **control lock** for three seconds. When in this mode, the display will show “LOC” when any button is pressed. Deactivate by pressing the **control lock** button again for three seconds. The display will then show “ULC” when the buttons are unlocked.

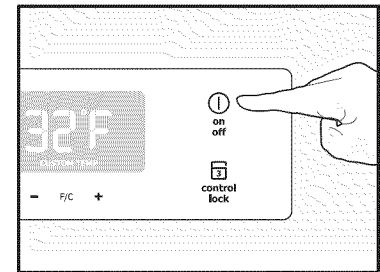

Turning Perfect Temp Drawer ON/OFF

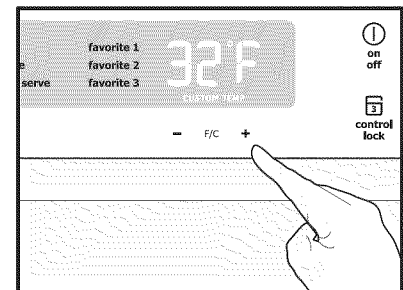

Setting Perfect Temp Drawer Temperature

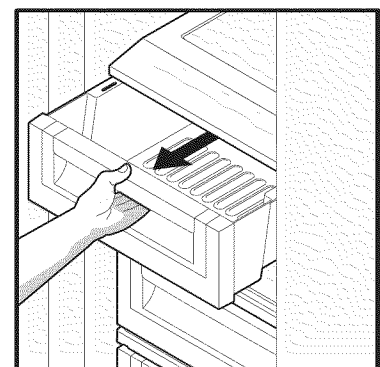

Opening Perfect Temp Drawer

## IMPORTANT

The two drop in insulating inserts need to remain in place while the Perfect Temp Drawer is on. Removing the inserts will cause the temperature of the crispers below it to be affected.

The drop in insulating inserts can be hand washed with mild soap. Do not wash in a dishwasher.

Do not clean the display area of the Perfect Temp Drawer with abrasive or caustic cleaners. Wipe clean with a moist sponge.

## NOTE

When turned off the Perfect Temp Drawer functions as a non temperature controlled drawer.

The Perfect Temp Drawer is intended for packaged food products only. Leafy vegetables and unpackaged fruits are best kept in one of the lower crisper drawers.

The thaw setting holds a temperature for thawing frozen foods for a specific amount of time. At the end of that time, it then switches to the snacks setting to store the thawed food.

## CAUTION

The Perfect Temp Drawer and frame can be removed for cleaning but the control unit, attached to the back of the fridge, cannot be removed. Do not immerse the Perfect Temp Drawer frame in water. Clean with a damp cloth or sponge but prevent any liquid from getting into the connector.

To remove the Perfect Temp Drawer frame and pan for cleaning:

- 1 Using your thumb, press down on the plastic tab.
- 2 While holding down the plastic tab, lift front slightly and pull drawer up and out.

## NOTE

If there are no plastic tabs on your model, just lift front of drawer and pull up and out.

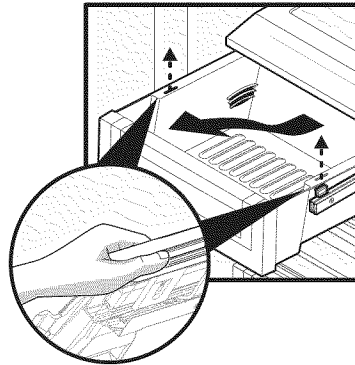

To remove the Perfect Temp Shelf Assembly:

- 1 Carefully unplug the connector located at the top right corner from the control unit under the shelf by pressing the catch release.

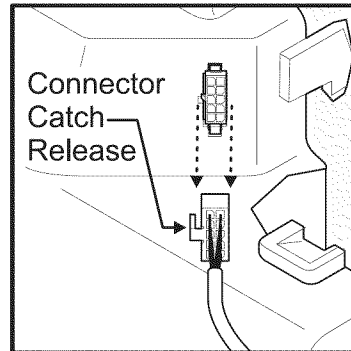

- 2 Pull the connector out.
- 3 Lift the front of the shelf assembly up off of the front support pins.

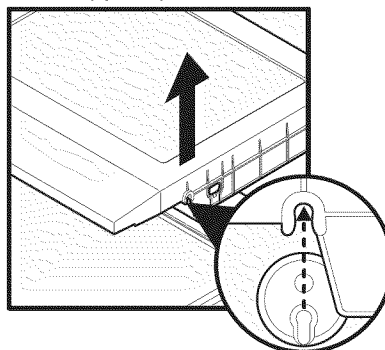

- 4 Pull the shelf assembly forward off of the rear support pins and out of the fridge.

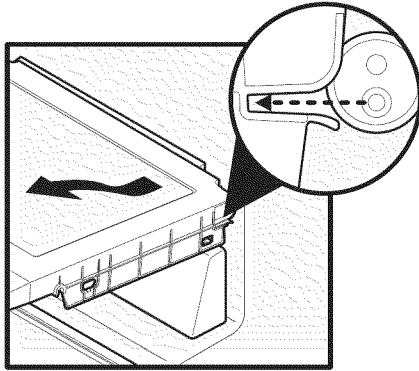

To reinstall the Perfect Temp Drawer Shelf Assembly:

- 1 Position rear of shelf assembly so that the rear support pins on the fridge liner slide into the support grooves in the rear of the shelf assembly.

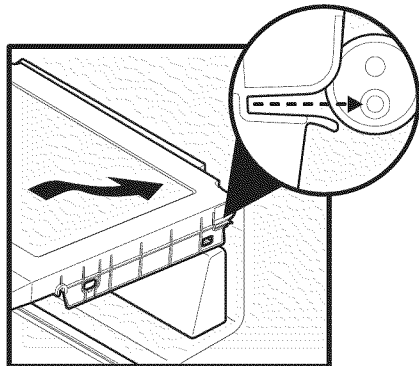

- 2 Slide the shelf assembly fully to the back of the fridge.
- 3 Lower the front of the shelf assembly so that the front support grooves in the shelf align with and the front support pins on the fridge liner.

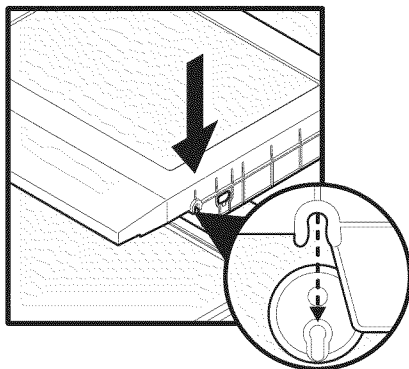

- 4 Drop the shelf down insuring that the support pins fully snap into the grooves in the shelf.
- 5 Reconnect the frame connector to the control unit and reinstall the drawer.

### Refrigerator on/off button and the Perfect Temp Drawer

When the refrigerator is turned off by pressing the main Wave-Touch or IQ-Touch on/off button the Perfect Temp Drawer will also be turned off. When the refrigerator is turned back on the Perfect Temp Drawer will resume operation at the temp setting that was set before the refrigerator was turned off.

### Sabbath Mode and the Perfect Temp Drawer

The Perfect Temperature Drawer should be turned off for the Sabbath/Holidays. Before putting the refrigerator into the Sabbath mode, turn the Perfect Temp Drawer off by pressing the drawer **on/off** button. The display will show "OFF" and the drawer will turn off. Then enter the Sabbath mode function on the main refrigerator display. See Wave-Touch/IQ-Touch "Sabbath Mode" section. The drawer display will now not illuminate and the drawer will remain off. The drawer can still be used as a non temp controlled drawer in this mode. When the refrigerator is taken out of Sabbath mode the Perfect Temp Drawer will have to be turned back on.

## Doors

### Storage bins

The doors to your freezer and fresh food compartments use a system of modular storage bins. All of these bins are removable for easy cleaning. Some of them have fixed positions, while others can be adjusted to your needs.

Door bins are ideal for storing jars, bottles, cans, and large drink containers. They also enable quick selection of frequently used items.



## To change the position of an adjustable door bin:

- 1 Before adjusting a bin, remove all food.
- 2 Grip the bin firmly with both hands and lift it upward.
- 3 Remove the bin.
- 4 Place the bin just above desired position.
- 5 Lower the bin onto supports until locked in place.

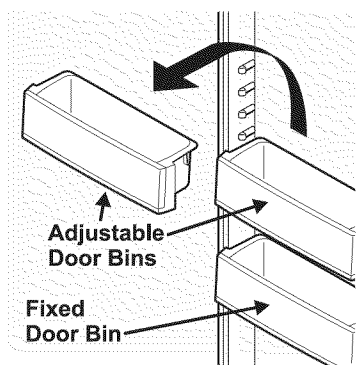
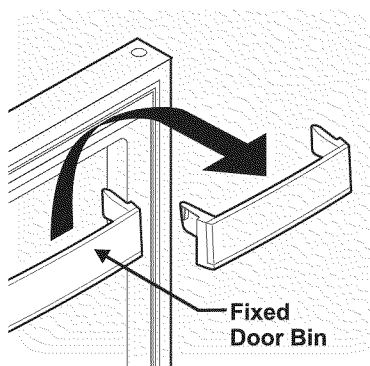

## Accessories (varies by model)

### Can rack

The can rack allows you to efficiently and securely store 12-ounce cans of beverage. A rubber liner sits behind the cans to help keep them secure. Liner may be removed for storing larger items.

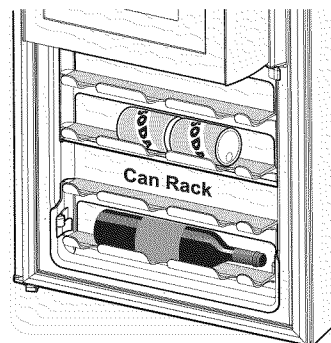

### Perfect Door Bin (some models)

The Perfect Door Bin is especially designed to hold gallon-sized containers like milk gallons. The door bin tilts out to provide convenient storage for fresh greens and other items.

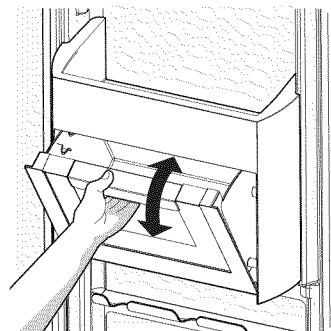

### Pizza rack (some models)

This rack is attached to the freezer wall beside the ice dispenser container. This convenient area allows for storage of pizza and other tall items placed vertically between the ice dispenser container and the freezer wall.

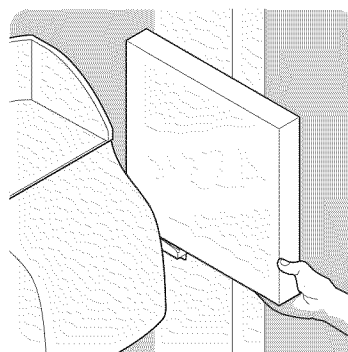

## Soft Freeze Bin (some models)

The soft freeze bin in the top of the freezer door is designed to maintain temperatures a few degrees above the freezer temperature to provide soft serve ice cream.

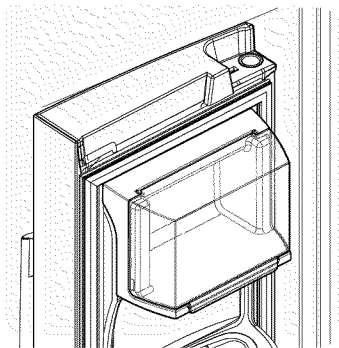

## Special item mat (some models)

The innovative design of the special item mat allows you to store four (4) bottles of wine or soft drink bottles, or any item that you want to prevent moving around.

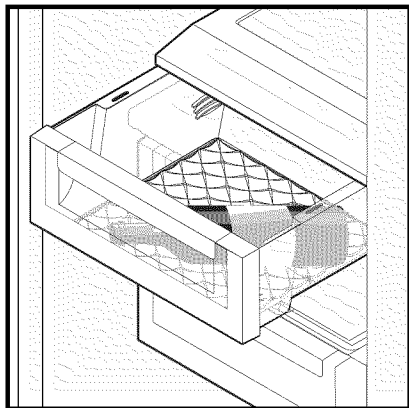

### NOTE

Any meat to be kept longer than two (2) days should be frozen. If you store fruits or vegetables in this drawer, set it to a higher humidity.

---

## Priming the water supply system

Your refrigerator's water supply system includes several tubing lines, an advanced water filter, a distribution valve bank, and a reserve tank to ensure ample supply to the ice and water dispenser at all times. This system needs to be completely filled with water when first connected to an external supply line.

### CAUTION

**For proper dispenser operation, recommended water supply pressure should fall between 30 psi and 100 psi. Excessive pressure may cause water filter to malfunction.**

### To prime the water supply system:

- 1 Begin filling the tank by pressing and holding a drinking glass against the water dispenser paddle.
- 2 Keep the glass in this position until water comes out of the dispenser. **It may take about 1½ minutes.**
- 3 Continue dispensing water for about three minutes to flush the system and plumbing connections of any impurities (stopping to empty the glass as necessary).

### NOTE

The water dispenser has a built-in device that shuts off the water flow after three minutes of continuous use. To reset this shutoff device, simply release the dispenser paddle.

## Ice maker operation & care

The ice maker, ice bin, and dispenser feeding mechanism are located in the top of the freezer compartment. After the refrigerator is installed properly and has cooled for several hours, the ice maker can produce ice within 24 hours. It can completely fill an ice bin in about two days.

The ice maker produces four to six pounds of ice every 24 hours depending on usage conditions. Ice is produced at a rate of eight cubes every 75 to 90 minutes.

## Using the ice maker after installation

Before making ice for the first time, be sure to prime the water supply system. Air in new plumbing lines can result in two or three empty ice maker cycles. Furthermore, if the system is not flushed, the first ice cubes may be discolored or have an odd flavor.

### IMPORTANT

Your ice maker is turned on at the factory so it can work as soon as you install your refrigerator. If you cannot connect a water supply, turn the ice maker's On/Off switch to Off. Otherwise, the ice maker's fill valve may make a loud chattering noise when it attempts to operate without water.

## Turning the ice maker on and off

Ice production is controlled by the ice maker's **On/Off** power switch. To gain access to the ice maker, pull the extra shelf out (some models). Press the switch to the "O" position to turn it Off and press to the "I" position to turn it On.

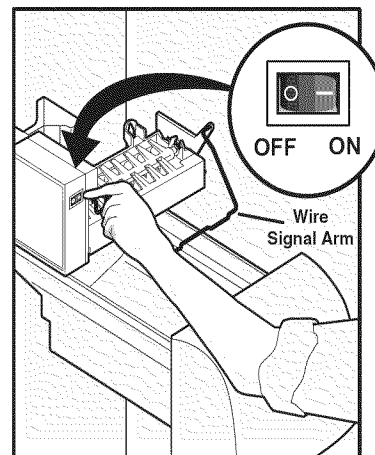

### NOTE

The ice maker also has a built-in wire signal arm, which automatically stops ice production when the ice bin is full. This signal arm should not be used to manually stop the ice maker.



## IMPORTANT

Small ice cubes or ice chips jamming in the ice maker may be a sign that your water filter needs changing. If you have a side mounted ice maker you may also experience hollow cubes -- partially frozen cubes with water inside. When these cubes are harvested they break open and spill water over the other ice cubes in the ice container, forming a solid mass of ice. As the water filter nears the end of its useful life and becomes clogged with particles, less water is delivered to the ice maker during each cycle. The ice maker can't fill every cube in the ice maker mold, leading to small cubes or chips that can get caught between the ice ejector blades and the stripper. Remember, if your ice maker is jamming with small ice cubes or it's been six months or longer since you last changed your water filter -- replace the water filter with a new one. Poor quality household water may require the filter to be changed more frequently.

### Ice maker/dispenser tips

- Ice cubes stored too long may develop an odd flavor. Empty the ice container as explained below.
- Occasionally shake the ice container to keep ice separated.
- If your refrigerator is not connected to a water supply or the water supply is turned off, turn off the ice maker by pressing the **On/Off** switch.
- If you need a large quantity of ice at one time, it is best to get cubes directly from the ice container.
- The following sounds are normal when the ice maker is operating:
  - Motor running
  - Ice dropping into ice container
  - Water valve opening or closing
  - Ice loosening from tray
  - Running water
- When dispensing ice, you will hear a snapping or clicking sound when the ice chute opens and closes.

- Turn off the ice maker when cleaning the freezer and during vacations.
- If you turn off the ice maker for a long period of time, you should also turn off the water supply valve.



## CAUTION

**Chemicals from a malfunctioning water softener can damage the ice maker. If the water supply to your refrigerator is softened, be sure the softener is maintained to work properly.**

### Cleaning the ice maker

Clean the ice maker and ice bin at regular intervals, particularly before you take a vacation or move.

#### To clean the ice maker:

- 1 Turn off ice production by pressing the ice maker's **Off/On** switch.
- 2 Remove the ice bin by lifting up and out.
- 3 Empty and carefully clean the ice bin with mild detergent. Rinse with clear water. Do not use harsh or abrasive cleaners.
- 4 Allow the ice bin to dry completely before replacing in the freezer.
- 5 Remove ice chips and clean the ice bin shelf and the freezer door chute.
- 6 Replace the ice bin. Press the ice maker's **Off/On** switch to resume ice production.

#### Remove and empty the ice storage bin if:

- An extended power failure (one hour or longer) causes ice cubes in the ice storage bin to melt and freeze together, jamming the dispenser mechanism.
- You do not use the ice dispenser frequently. Ice cubes will freeze together in the bin, jamming the dispenser mechanism.

Remove the ice storage bin and shake to loosen the cubes or clean as explained above.

## CAUTION

**NEVER** use an ice pick or similar sharp instrument to break up the ice. This could damage the ice storage bin and dispenser mechanism.

## IMPORTANT

When removing or replacing the ice bin, **DO NOT** rotate the auger in the ice bin. If the auger is accidentally rotated, you must realign the auger by turning it in 90 degree turns (see below) until the ice bin fits into place with the drive mechanism. **If the auger is not** properly aligned when replacing the ice bin, the refrigerator will only dispense Crushed Ice. The freezer door may also not close properly causing warm air to leak into the freezer.

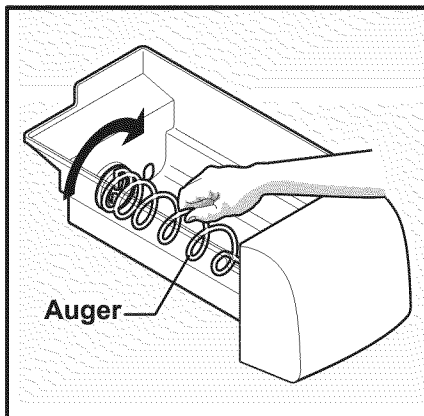

## Locating the filters

Your refrigerator is equipped with separate water and air filtering systems. The water filter system filters all dispensed drinking water, as well as the water used to produce ice. The air filter removes odors and impurities from the refrigerator compartment.

### Water filter

The water filter is located at the top right side of the fresh food compartment.

### Air filter

The air filter is located at the top of the fresh food compartment next to the water filter.

## Replacing the air filter

In general, you should change the air filter every six months (the filter status light on the Touch Panel prompts you to replace the filter after six months) to ensure optimal filtering of refrigerator odors. You may want to adjust this time period depending on the types and amounts of food you typically store in your refrigerator. To replace your *PureAdvantage™* air filter:

- 1 Pull the air filter housing straight out.
- 2 Remove the old filter and discard it.
- 3 Unpack the new filter and place it inside the housing.
- 4 Slide the housing back into position.
- 5 Press and hold the **Air Filter Reset** button on the electronic control panel for three seconds. When the display changes from “**Replace**” to “**Good**,” the status has been reset.
- 6 The **Air Filter Reset** will turn itself off after a few seconds.

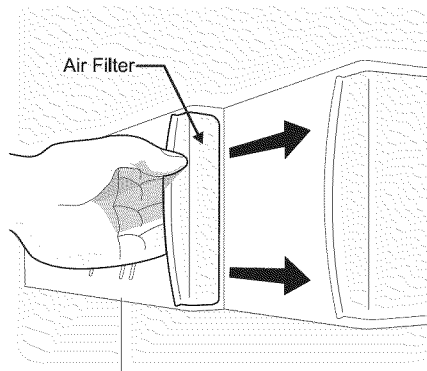

## NOTE

The electronic touch panel, located at the freezer door, includes controls to monitor the status of your air filter. See the Controls section for more information about these controls.

## Replacing the water filter

In general, you should change the water filter every six months to ensure highest possible water quality. The **Water Filter Status** light on the Touch Panel prompts you to replace the filter after a standard amount of water (400 gallons for *PureAdvantage™*) has flowed through the system.

If your refrigerator has not been used for a period of time (during moving for example), change the filter before reinstalling the refrigerator.

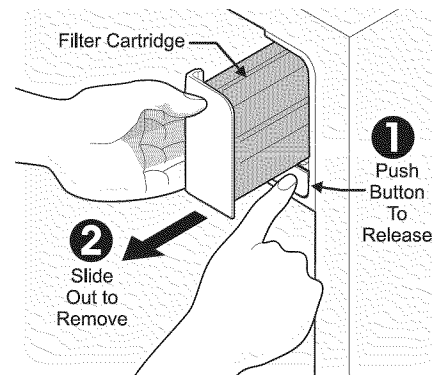

## Ordering replacement filters

Order new filters by calling toll-free, 877/808-4195, visiting [www.electroluxappliances.com](http://www.electroluxappliances.com), or seeing the dealer where you bought your refrigerator. Electrolux recommends that you order extra filters when you first install your refrigerator, and that you replace your filters at least once every six months.

Here is the product number to request when ordering:

**PureAdvantage™**  
 Water Filter - Part #EWFO1  
 Air Filter - Part #EAFCBF



## More about your advanced water filter

The *PureAdvantage*<sup>™</sup> ice and water filter system is tested and certified by NSF International to NSF/ANSI Standards 42 and 53 for the reduction of claims specified on the performance data sheet.

Do not use with water that is microbiologically unsafe or of unknown quality without adequate disinfection before or after the system. Systems certified for cyst reduction may be used on disinfected waters that may contain filterable cysts.

### Test & certification results:

- Rated Capacity - 400 gallons for *PureAdvantage*<sup>™</sup> ice and water filter
- Rated service flow - .5 gallons per minute
- Maximum Rated Pressure - 100 pounds per square inch
- Operating Temp.: Min. 33° F, Max. 100° F
- Recommended Minimum Operating Pressure: 30 pounds per square inch

### To replace your *PureAdvantage*<sup>™</sup> water filter:

It is not necessary to turn the water supply off to change the filter. Be ready to wipe up any small amounts of water released during the filter replacement.

- 1 Turn **Off** the ice maker power switch.
- 2 Push the filter release button below the cartridge to disconnect it.
- 3 Slide the old water filter cartridge straight out of the housing and discard it.
- 4 Unpackage the new filter cartridge and slide it gently into the filter housing until it stops against the snap-in connector at the back of the housing.
- 5 **Push firmly until the cartridge snaps into place (you should hear a click as the cartridge engages the snap-in connector).** When fully engaged, the front of the filter cartridge should be flush with the filter release button.
- 6 Press a drinking glass against the water dispenser while checking for any leaks at the filter housing. Any spurts and sputters that

occur as the system purges air out of the dispenser system are normal.

- 7 After filling one glass of water, continue flushing the system for about **three minutes**.
- 8 Turn **On** the ice maker.
- 9 Press and hold the **Filter Status** button on the Ice & Water Dispenser control panel for three seconds. When the display changes from "**Replace**" to "**Good**," the status has been reset.

## Ideas for storing foods

### Fresh food storage

- Keep the fresh food compartment between 34° F and 40° F with an optimum temperature of 37° F.
- Avoid overcrowding the refrigerator shelves, which reduces air circulation and causes uneven cooling.

### Fruits and vegetables

- Store fruits and vegetables in crisper drawers, where trapped moisture helps preserve food quality for longer time periods.

### Meat

- Wrap raw meat and poultry securely so leakage and contamination of other foods or surfaces does not occur.
- Use the meat keeper drawer for short-term storage. Any meat to be kept longer than two days should be frozen.

### Frozen food storage

- Keep the freezer compartment at 0° F or lower.
- A freezer operates most efficiently when it is at least  $\frac{2}{3}$  full.

### Packaging foods for freezing

- To minimize food dehydration and quality deterioration, use aluminum foil, freezer wrap, freezer bags or airtight containers. Force as much air out of the packages as possible and seal them tightly. Trapped air can cause food to dry out, change color, and develop an off-flavor (freezer burn).
- Wrap fresh meats and poultry with suitable freezer wrap prior to freezing.
- Do not refreeze meat that has completely thawed.

### Loading the freezer

- Avoid adding too much warm food to the freezer at one time. This overloads the freezer, slows the rate of freezing, and can raise the temperature of frozen foods.
- Leave a space between packages, so cold air can circulate freely, allowing food to freeze as quickly as possible.
- Avoid storing hard-to-freeze foods on the freezer door shelves. These foods are best

stored in the freezer interior where the temperature varies less.

## Ideas for saving energy

### Installation

- Locate the refrigerator in the coolest part of the room, out of direct sunlight, and away from heating ducts or registers. Do not place the refrigerator next to heat-producing appliances such as a range, oven, or dishwasher. If this is not possible, a section of cabinetry or an added layer of insulation between the two appliances will help the refrigerator operate more efficiently.
- Level the refrigerator so that the doors close tightly.

### Temperature settings

- Refer to the “Controls” section in this Use & Care Guide for procedures on temperature settings.

### Food storage

- Avoid overcrowding the refrigerator or blocking cold air vents. Doing so causes the refrigerator to run longer and use more energy.
- Cover foods and wipe containers dry before placing them in the refrigerator. This cuts down on moisture build-up inside the unit.
- Organize the refrigerator to reduce door openings. Remove as many items as needed at one time and close the door as soon as possible.



## Understanding the sounds you may hear

Your new, high-efficiency refrigerator may introduce unfamiliar sounds. These sounds normally indicate your refrigerator is operating correctly. Some surfaces on floors, walls, and kitchen cabinets may make these sounds more noticeable.

Following is a list of major components in your refrigerator and the sounds they can cause:

- A Evaporator** Refrigerant through the evaporator may create a boiling or gurgling sound.
- B Evaporator fan** You may hear air being forced through the refrigerator by the evaporator fan.
- C Defrost heater** During defrost cycles, water dripping onto the defrost heater may cause a hissing or sizzling sound. After defrosting, a popping sound may occur.
- D Automatic ice maker** When ice has been produced, you will hear ice cubes falling into the ice bin.
- E Electronic control & automatic defrost control** These parts can produce a snapping or clicking sound when turning the cooling system on and off.
- F Condenser fan** You may hear air being forced through the condenser.
- G Compressor** Modern, high-efficiency compressors run much faster than in the past. The compressor may have a high-pitched hum or pulsating sound.
- H Water valve** Makes a buzzing sound each time it opens to fill the ice maker.
- I Drain pan** (not removable) You may hear water dripping into the drain pan during the defrost cycle.
- J Condenser** May create minimal sounds from forced air.
- K Motorized damper** May produce a light humming during operation.
- L Ice dispensing paddle** When dispensing ice, you will hear a snapping or clicking sound when the solenoid opens and closes the ice chute.

- M Perfect Temp Drawer (some models)** Fans run intermittently when door is closed but turn off when door is opened (except when fridge is in Sabbath Mode). Air control valve may produce a light humming during operation.

 **NOTE**

Energy efficient foam in your refrigerator is not a sound insulator.

 **NOTE**

During automatic defrost cycle, a red glow in the back wall vents of your freezer compartment is normal.

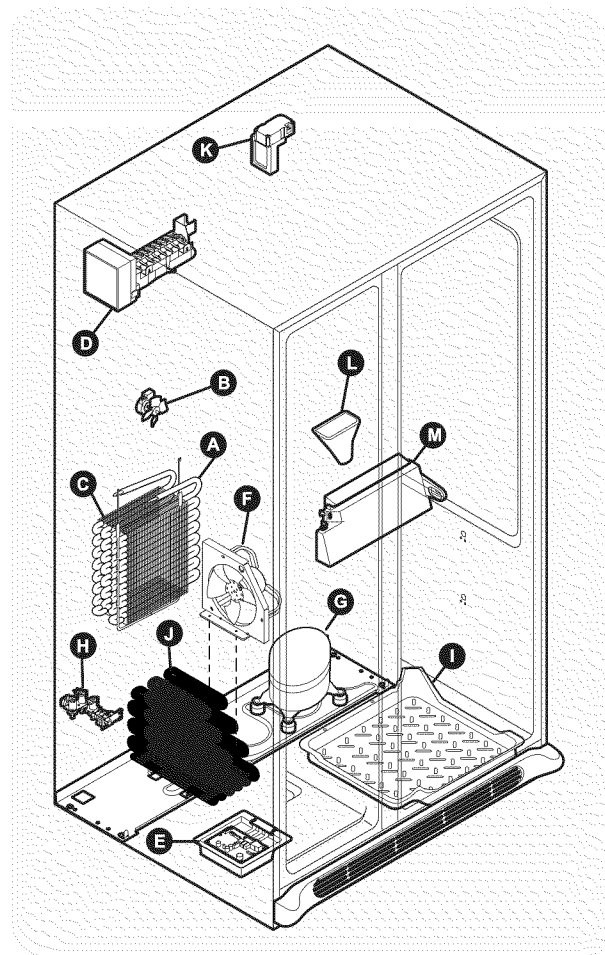

## Protecting your investment

Keeping your refrigerator clean maintains appearance and prevents odor build-up. Wipe up any spills immediately and clean the freezer and fresh food compartments at least twice a year. When cleaning, take the following precautions:

### NOTE

Do not use abrasive cleaners such as window sprays, scouring cleansers, flammable fluids, cleaning waxes, concentrated detergents, bleaches or cleansers containing petroleum products on plastic parts, interior doors, gaskets or cabinet liners. Do not use paper towels, scouring pads, or other abrasive cleaning materials.

- Never use metallic scouring pads, brushes, abrasive cleaners or strong alkaline solutions on any surface.
- Never use CHLORIDE or cleaners with bleach to clean stainless steel.
- Do not wash any removable parts in a dishwasher.
- Always unplug the electrical power cord from the wall outlet before cleaning.

### NOTE

If you set your temperature controls to turn off cooling, power to lights and other electrical components will continue until you unplug the power cord from the wall outlet.

- Remove adhesive labels by hand. Do not use razor blades or other sharp instruments which can scratch the appliance surface.
- Do not remove the serial plate.

### CAUTION

- **Pull the refrigerator straight out to move it. Shifting it from side to side may damage flooring. Be careful not to move the refrigerator beyond the plumbing connections.**
- **Damp objects stick to cold metal surfaces. Do not touch refrigerated surfaces with wet or damp hands.**

### IMPORTANT

If you store or move your refrigerator in freezing temperatures, be sure to completely drain the water supply system. Failure to do so could result in water leaks when the refrigerator is put back into service. Contact a service representative to perform this operation.

Refer to the guide on the next page for details on caring and cleaning specific areas of your refrigerator.

## Care & cleaning tips

Part	Cleaning Agents	Tips and Precautions
Interior & Door Liners	<ul style="list-style-type: none"> <li>• Soap and water</li> <li>• Baking soda and water</li> </ul>	<ul style="list-style-type: none"> <li>• Use 2 tablespoons of baking soda in 1 quart of warm water.</li> <li>• Be sure to wring excess water out of sponge or cloth before cleaning around controls, LED lights or any electrical part.</li> </ul>
Door Gaskets	<ul style="list-style-type: none"> <li>• Soap and water</li> </ul>	<ul style="list-style-type: none"> <li>• Wipe gaskets with a clean soft cloth.</li> </ul>
Drawers & Bins	<ul style="list-style-type: none"> <li>• Soap and water</li> </ul>	<ul style="list-style-type: none"> <li>• Use a soft cloth to clean drawer runners and tracks.</li> <li>• Do not wash any removable items (bins, drawers, etc.) in dishwasher.</li> </ul>
Glass Shelves	<ul style="list-style-type: none"> <li>• Soap and water</li> <li>• Glass cleaner</li> <li>• Mild liquid sprays</li> </ul>	<ul style="list-style-type: none"> <li>• Allow glass to warm to room temperature before immersing in warm water.</li> </ul>
Toe Grille	<ul style="list-style-type: none"> <li>• Soap and water</li> <li>• Mild liquid sprays</li> <li>• Vacuum attachment</li> </ul>	<ul style="list-style-type: none"> <li>• Vacuum dust from front of toe grille.</li> <li>• Remove toe grille (see Installation Instructions).</li> <li>• Vacuum backside and wipe with sudsy cloth or sponge. Rinse and dry.</li> </ul>
Exterior & Handles	<ul style="list-style-type: none"> <li>• Soap and water</li> <li>• Non abrasive glass cleaner</li> </ul>	<ul style="list-style-type: none"> <li>• Do not use commercial household cleaners containing ammonia, bleach or alcohol to clean handles.</li> <li>• Use a soft cloth to clean smooth handles.</li> <li>• Do not use a dry cloth to clean smooth doors.</li> </ul>
Exterior & Handles (Stainless Steel Models Only)	<ul style="list-style-type: none"> <li>• Soap and water</li> <li>• Stainless steel cleaners</li> </ul>	<ul style="list-style-type: none"> <li>• <b>Never use CHLORIDE or cleaners with bleach to clean stainless steel.</b></li> <li>• Clean stainless steel front and handles with non-abrasive soapy water and a dishcloth. Rinse with clean water and a soft cloth.</li> <li>• Use a non-abrasive stainless steel cleaner. These cleaners can be purchased at most home improvement or major department stores. Always follow manufacturer's instruction. Do not use household cleaners containing ammonia or bleach.</li> <li>• NOTE: Always clean, wipe and dry with grain to prevent scratching.</li> <li>• Wash the rest of the cabinet with warm water and mild liquid detergent. Rinse well and wipe dry with a clean soft cloth.</li> </ul>
User Interface Panel	<ul style="list-style-type: none"> <li>• Soap and water</li> </ul>	<ul style="list-style-type: none"> <li>• Do not use commercial household cleaners containing ammonia, bleach or alcohol to clean user interface panel.</li> <li>• Use a soft cloth to clean user interface panel.</li> <li>• Do not use a dry cloth to clean user interface panel.</li> </ul>

## Vacation & moving tips

Occasion	Tips
Short Vacations	<ul style="list-style-type: none"> <li>• Leave refrigerator operating during vacations of 3 weeks or less.</li> <li>• Use all perishable items from refrigerator compartment.</li> <li>• Turn automatic ice maker off and empty ice bucket, even if you will only be gone for a few days.</li> </ul>
Long Vacations	<ul style="list-style-type: none"> <li>• Remove all food and ice if you will be gone one month or more.</li> <li>• Turn the cooling system off (see "Controls" section for location of On/Off button) and disconnect power cord.</li> <li>• Turn off automatic ice maker and turn water supply valve to closed position.</li> <li>• Clean interior thoroughly.</li> <li>• Leave both doors open to prevent odors and mold build-up. Block doors open if necessary.</li> </ul>
Moving	<ul style="list-style-type: none"> <li>• Remove all food and ice.</li> <li>• If using handcart, load from side.</li> <li>• Adjust rollers all the way up to protect them during sliding or moving.</li> <li>• Pad cabinet to avoid scratching surface.</li> </ul>

## Replacing LED Lights

Both the freezer and fresh food compartments of your refrigerator include LED lights. Always use Electrolux parts for replacement.

### To replace LED Lights:

- 1 Unplug your refrigerator's power cord.
- 2 Remove light cover by pushing up and out.
- 3 Hold the LED cover with one hand and pull the connector with the other hand while pressing the connector latch.
- 4 Replace LED light and snap in place assuring the light is facing in toward the unit (inside fresh food and freezer) or facing outward on bottom of fresh food doors.

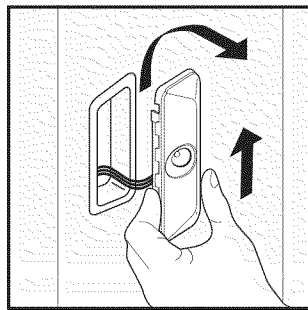

LED Light Removal

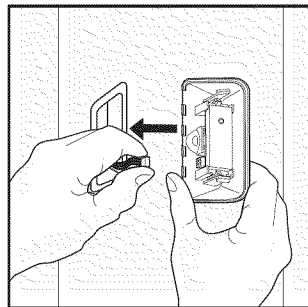

LED Light Harness Removal



### NOTE

LED lights are in series so if one is bad or unplugged, several lights may not light up.

### Ordering Replacement LED Lights

Order new LEDs by calling 877-808-4195, online at [www.electroluxicon.com](http://www.electroluxicon.com), or through the dealer where you bought the refrigerator.

### Major Appliance Warranty Information

Your appliance is covered by a one year limited warranty. For one year from your original date of purchase, Electrolux will repair or replace any parts of this appliance that prove to be defective in materials or workmanship when such appliance is installed, used, and maintained in accordance with the provided instructions. In addition, the cabinet liner and sealed refrigeration system (compressor, condenser, evaporator, dryer or tubing) of your appliance is covered by a two through five year limited warranty. During the 2nd through 5th years from your original date of purchase, Electrolux will repair or replace any parts in the cabinet liner and sealed refrigeration system which prove to be defective in materials or workmanship when such appliance is installed, used, and maintained in accordance with the provided instructions.

#### Exclusions

This warranty does not cover the following:

1. Products with original serial numbers that have been removed, altered or cannot be readily determined.
2. Product that has been transferred from its original owner to another party or removed outside the USA or Canada.
3. Rust on the interior or exterior of the unit.
4. Products purchased "as-is" are not covered by this warranty.
5. Food loss due to any refrigerator or freezer failures.
6. Products used in a commercial setting.
7. Service calls which do not involve malfunction or defects in materials or workmanship, or for appliances not in ordinary household use or used other than in accordance with the provided instructions.
8. Service calls to correct the installation of your appliance or to instruct you how to use your appliance.
9. Expenses for making the appliance accessible for servicing, such as removal of trim, cupboards, shelves, etc., which are not a part of the appliance when it is shipped from the factory.
10. Service calls to repair or replace appliance light bulbs, air filters, water filters, other consumables, or knobs, handles, or other cosmetic parts.
11. Pickup and delivery costs; your appliance is designed to be repaired in the home.
12. Surcharges including, but not limited to, any after hour, weekend, or holiday service calls, tolls, ferry trip charges, or mileage expense for service calls to remote areas, including the state of Alaska.
13. Damages to the finish of appliance or home incurred during transportation or installation, including but not limited to floors, cabinets, walls, etc.
14. Damages caused by: services performed by unauthorized service companies; use of parts other than genuine Electrolux parts or parts obtained from persons other than authorized service companies; or external causes such as abuse, misuse, inadequate power supply, accidents, fires, or acts of God.

#### DISCLAIMER OF IMPLIED WARRANTIES; LIMITATION OF REMEDIES

CUSTOMER'S SOLE AND EXCLUSIVE REMEDY UNDER THIS LIMITED WARRANTY SHALL BE REPAIR OR REPLACEMENT AS PROVIDED HEREIN. **CLAIMS BASED ON IMPLIED WARRANTIES, INCLUDING WARRANTIES OF MERCHANTABILITY OR FITNESS FOR A PARTICULAR PURPOSE, ARE LIMITED TO ONE YEAR OR THE SHORTEST PERIOD ALLOWED BY LAW, BUT NOT LESS THAN ONE YEAR.** ELECTROLUX SHALL NOT BE LIABLE FOR CONSEQUENTIAL OR INCIDENTAL DAMAGES SUCH AS PROPERTY DAMAGE AND INCIDENTAL EXPENSES RESULTING FROM ANY BREACH OF THIS WRITTEN LIMITED WARRANTY OR ANY IMPLIED WARRANTY. SOME STATES AND PROVINCES DO NOT ALLOW THE EXCLUSION OR LIMITATION OF INCIDENTAL OR CONSEQUENTIAL DAMAGES, OR LIMITATIONS ON THE DURATION OF IMPLIED WARRANTIES, SO THESE LIMITATIONS OR EXCLUSIONS MAY NOT APPLY TO YOU. THIS WRITTEN WARRANTY GIVES YOU SPECIFIC LEGAL RIGHTS. YOU MAY ALSO HAVE OTHER RIGHTS THAT VARY FROM STATE TO STATE.

#### If You Need Service

Keep your receipt, delivery slip, or some other appropriate payment record to establish the warranty period should service be required. If service is performed, it is in your best interest to obtain and keep all receipts. Service under this warranty must be obtained by contacting Electrolux at the addresses or phone numbers below.

This warranty only applies in the USA, Puerto Rico and Canada. In the USA and Puerto Rico, your appliance is warranted by Electrolux Major Appliances North America, a division of Electrolux Home Products, Inc. In Canada, your appliance is warranted by Electrolux Canada Corp. Electrolux authorizes no person to change or add to any obligations under this warranty. Obligations for service and parts under this warranty must be performed by Electrolux or an authorized service company. Product features or specifications as described or illustrated are subject to change without notice.

#### USA

1-877-435-3287

Electrolux Major Appliances North America  
10200 David Taylor Drive  
Charlotte, NC 28262

#### Canada

1-800-265-8352

Electrolux Canada Corp.  
5855 Terry Fox Way  
Mississauga, Ontario, Canada L5V 3E4

## Before you call...

If you experience a problem with your refrigerator or notice a product behavior or condition you do not understand, you can usually avoid a call to your service representative by referring to this section for an answer. Beginning with the following table, this information includes common problems, causes, and suggested solutions.

### Running Your Refrigerator

Concern	Cause	Solution
Compressor does not run.	<ul style="list-style-type: none"> <li>• Cooling system is turned Off.</li> <li>• Refrigerator is in defrost cycle.</li> <li>• Plug at wall outlet is disconnected.</li> <li>• House fuse blown or tripped circuit breaker.</li> <li>• Power outage.</li> </ul>	<ul style="list-style-type: none"> <li>• Turn cooling system On. See <b>Controls</b> Section for location of cooling system On/Off button.</li> <li>• This is normal for a fully automatic defrost refrigerator. The defrost cycle occurs periodically, lasting about 30 minutes.</li> <li>• Ensure plug is tightly pushed into outlet.</li> <li>• Check/replace fuse with a 15 amp time-delay fuse. Reset circuit breaker.</li> <li>• Check house lights. Call local Electric Company.</li> </ul>
Refrigerator runs too much or too long.	<ul style="list-style-type: none"> <li>• Room or outside weather is hot.</li> <li>• Refrigerator has recently been disconnected for a period of time.</li> <li>• Automatic ice maker is operating.</li> <li>• Doors are opened too frequently or too long.</li> <li>• Refrigerator/freezer door may be slightly open.</li> <li>• Freezer control is set too cold (control found in fresh food section).</li> <li>• Fresh food/freezer gasket is dirty, worn, cracked, or poorly fitted.</li> </ul>	<ul style="list-style-type: none"> <li>• It's normal for the refrigerator to work longer under these conditions.</li> <li>• It takes 8-12 hours for the refrigerator to cool down completely.</li> <li>• Ice maker operation causes refrigerator to run slightly more.</li> <li>• Warm air entering the refrigerator causes it to run more. Open doors less often.</li> <li>• Ensure refrigerator is level. Keep food and containers from blocking door. See <b>Problem</b> section, <i>Opening/Closing of Doors/ Drawers</i>.</li> <li>• Set freezer control to warmer setting until refrigerator temperature is satisfactory. Allow 24 hours for temperature to stabilize.</li> <li>• Clean or change gasket. Leaks in door seal will cause refrigerator to run longer in order to maintain desired temperatures.</li> </ul>
Compressor does not run.	<ul style="list-style-type: none"> <li>• Electronic control system keeps the refrigerator at a constant temperature.</li> </ul>	<ul style="list-style-type: none"> <li>• This is normal. Refrigerator goes on and off to keep temperature constant.</li> </ul>
Digital temperature displays are flashing.	<ul style="list-style-type: none"> <li>• Electronic control system has detected a performance problem.</li> </ul>	<ul style="list-style-type: none"> <li>• Call your Electrolux service representative, who can interpret any messages or number codes flashing on the digital displays.</li> </ul>

### Temperatures Are Too Cold

Concern	Cause	Solution
Freezer temperature too cold. Refrigerator temperature is satisfactory.	<ul style="list-style-type: none"> <li>• Freezer control is set too cold.</li> </ul>	<ul style="list-style-type: none"> <li>• Set freezer control to a warmer setting. Allow 24 hours for temperature to stabilize.</li> </ul>
Refrigerator temperature too cold. Freezer temperature is satisfactory.	<ul style="list-style-type: none"> <li>• Refrigerator control is set too cold.</li> </ul>	<ul style="list-style-type: none"> <li>• Set refrigerator control to a warmer setting. Allow 24 hours for temperature to stabilize.</li> </ul>
Food stored in drawers freezes.	<ul style="list-style-type: none"> <li>• Refrigerator control is set too cold.</li> </ul>	<ul style="list-style-type: none"> <li>• See solution above.</li> </ul>
Food stored in Meat Keeper freezes (some models).	<ul style="list-style-type: none"> <li>• Meat Keeper temperature control is set too cold.</li> </ul>	<ul style="list-style-type: none"> <li>• Adjust Meat Keeper temperature control to a lower setting. Meat should be stored at a temperature just below the freezing point for maximum fresh storage time. It is normal for ice crystals to form due to the moisture content of meat.</li> </ul>

## Temperatures Are Too Warm

Concern	Cause	Solution
Freezer/Refrigerator temperature is too warm.	<ul style="list-style-type: none"> <li>Doors are opened too frequently or too long.</li> <li>Door is slightly open.</li> </ul>	<ul style="list-style-type: none"> <li>Warm air enters the refrigerator whenever the door is opened. Open the door less often.</li> <li>See <b>Problem</b> section, <i>Opening/Closing of Doors/Drawers</i>.</li> </ul>
Freezer temperature is too warm. Refrigerator temperature is satisfactory.	<ul style="list-style-type: none"> <li>Freezer control is set too warm.</li> </ul>	<ul style="list-style-type: none"> <li>Set freezer control to a colder setting. Allow 24 hours for temperature to stabilize.</li> </ul>
Refrigerator temperature is too warm. Freezer temperature is satisfactory.	<ul style="list-style-type: none"> <li>Refrigerator control is set too warm.</li> </ul>	<ul style="list-style-type: none"> <li>Set refrigerator control to a colder setting. Allow 24 hours for temperature to stabilize.</li> </ul>
Temperature in the Meat Keeper is too warm (some models).	<ul style="list-style-type: none"> <li>Meat Keeper temperature control is set too warm.</li> </ul>	<ul style="list-style-type: none"> <li>Adjust Meat Keeper temperature control to a colder setting.</li> </ul>

## Water/Moisture/Frost Inside Refrigerator

Concern	Cause	Solution
Moisture collects on inside of refrigerator walls.	<ul style="list-style-type: none"> <li>Weather is hot and humid.</li> <li>Door is slightly open.</li> <li>Door is opened too often or too long.</li> <li>Open containers.</li> </ul>	<ul style="list-style-type: none"> <li>The rate of frost buildup and internal sweating increases.</li> <li>See <b>Problem</b> section, <i>Opening/Closing of Doors/Drawers</i>.</li> <li>Open door less often to allow internal temperature to stabilize.</li> <li>Keep containers covered.</li> </ul>
Water collects on bottom side of drawer cover.	<ul style="list-style-type: none"> <li>Vegetables contain and give off moisture.</li> </ul>	<ul style="list-style-type: none"> <li>Moisture on the bottom side of the cover is not unusual.</li> <li>Move humidity control (some models) to lower setting.</li> </ul>
Moisture collects in bottom of drawer.	<ul style="list-style-type: none"> <li>Washed vegetables and fruit drain while in the drawer.</li> <li>Fruits and vegetables are kept past their prime</li> </ul>	<ul style="list-style-type: none"> <li>Dry items before putting them in the drawer. Water collecting in bottom of drawer is normal.</li> <li>Routinely clean out old fruits and vegetables especially if they begin to break down.</li> </ul>
Moisture collects on outside of refrigerator or between doors.	<ul style="list-style-type: none"> <li>Weather is humid.</li> <li>Door is slightly open, causing cold air from inside refrigerator to meet warm air from outside.</li> </ul>	<ul style="list-style-type: none"> <li>This is normal in humid weather. When humidity is lower, the moisture should disappear.</li> <li>See <b>Problem</b> section, <i>Opening/Closing of Doors/Drawers</i>.</li> </ul>

## Perfect Temp Drawer (some models)

Concern	Cause	Solution
Display does not illuminate or shows "CE".	<ul style="list-style-type: none"> <li>Connector not connected or loose.</li> </ul>	<ul style="list-style-type: none"> <li>Remove pan and insure connector is fully engaged. (See <b>Storage Features</b> section)</li> </ul>
Display shows "LOC" when buttons are pressed.	<ul style="list-style-type: none"> <li>Drawer in control lock mode.</li> </ul>	<ul style="list-style-type: none"> <li>Press and hold control lock button for three seconds to take drawer out of control lock mode. (See <b>Storage Features</b> section)</li> </ul>

**Automatic Ice Maker**

<b>Concern</b>	<b>Cause</b>	<b>Solution</b>
Ice maker is not making any ice.	<ul style="list-style-type: none"> <li>• Ice maker power switch is Off.</li> <li>• Water supply is not connected to refrigerator.</li> <li>• Household water line valve is not open.</li> <li>• Freezer is not cold enough.</li> <li>• Household water line to the refrigerator is kinked.</li> <li>• Valve on cold water pipe is clogged or restricted by foreign material. If valve is of the self-piercing type, it may not have created a sufficiently sized hole in tube for water to pass through.</li> <li>• Check to see if the water dispenser is dispensing water.</li> <li>• Water filter is not completely seated.</li> </ul>	<ul style="list-style-type: none"> <li>• Turn on power switch.</li> <li>• Connect water supply (see <b>Installation Instructions</b>).</li> <li>• Turn on household water line valve.</li> <li>• See <b>Problem</b> section, <i>Temperatures Are Too Warm</i>.</li> <li>• Unkink the water line. If it is a copper line, it should be replaced because of possible leaks at the kink. A copper line should be coiled behind the unit to avoid kinking.</li> <li>• Turn off household water line valve. Remove valve. Ensure that valve is not a self-piercing valve. Clean valve. Replace valve if necessary.</li> <li>• If not, the ice &amp; water filter cartridge is clogged or restricted, and must be replaced.</li> <li>• Push firmly until the water filter snaps into place (you should hear two clicks).</li> </ul>
Ice maker is not making enough ice.	<ul style="list-style-type: none"> <li>• Ice maker is producing less ice than you expect.</li> <li>• Freezer is not cold enough.</li> <li>• Household water line valve is not completely open.</li> <li>• Check to see if water dispenser is dispensing slower than normal.</li> </ul>	<ul style="list-style-type: none"> <li>• Ice maker should produce approximately 4-5 pounds of ice every 24 hours. Fast Ice should produce up to 6 pounds of ice every 24 hours.</li> <li>• See <b>Problem</b> section, <i>Temperatures Are Too Warm</i>.</li> <li>• Turn on household water line valve.</li> <li>• If it is, replace the ice &amp; water filter cartridge.</li> </ul>
Ice maker will not stop making ice.	<ul style="list-style-type: none"> <li>• Ice maker wire signal arm is being held down by some item in the freezer.</li> </ul>	<ul style="list-style-type: none"> <li>• Move item and release wire signal arm. Remove any ice cubes frozen together over wire signal arm.</li> </ul>
Ice maker is not separating the ice cubes.	<ul style="list-style-type: none"> <li>• Ice cubes are not being used frequently enough.</li> <li>• Ice cubes are hollow or smaller than normal.</li> </ul>	<ul style="list-style-type: none"> <li>• Remove and shake ice bin to separate cubes.</li> <li>• The ice &amp; water filter cartridge may be clogged. Replace filter cartridge.</li> </ul>
Ice has bad odor and taste.	<ul style="list-style-type: none"> <li>• Ice has picked up odor or flavor from strong food stored in refrigerator or freezer.</li> <li>• Ice not used frequently enough.</li> </ul>	<ul style="list-style-type: none"> <li>• Cover foods tightly. Discard stale ice. Ice maker will produce fresh supply.</li> <li>• Discard stale ice.</li> </ul>



## Ice Dispenser

Concern	Cause	Solution
Dispenser will not dispense ice.	<ul style="list-style-type: none"> <li>• Water supply is not connected.</li> <li>• Household water line to the refrigerator is kinked.</li> <li>• Ice storage container is empty.</li> <li>• Freezer temperature is set too warm.</li> <li>• Household water line valve is not open.</li> <li>• Freezer door is not closed.</li> <li>• Ice dispensing arm has been held in for more than 4-5 minutes.</li> </ul>	<ul style="list-style-type: none"> <li>• Connect water supply (see <b>Connecting The Water Supply</b> section).</li> <li>• Unkink the water line. If it is a copper line, it should be replaced because of possible leaks at the kink. A copper line should be coiled behind the unit to avoid kinking.</li> <li>• Ensure ice maker is turned on. When the first supply of ice is dropped into the container, the dispenser should operate.</li> <li>• Turn freezer control to a higher setting so that ice cubes will be made. When first supply of ice is made, dispenser should operate.</li> <li>• Open household water line valve. Allow sufficient time for the ice to be made. When ice is made, the dispenser should operate.</li> <li>• Ensure freezer door is closed. (See <b>Problem</b> Section, <i>Opening/Closing of Doors/Drawers</i>)</li> <li>• Motor is overloaded. Motor overload protector will reset in approximately 3 minutes. Ice can then be dispensed.</li> </ul>
Ice dispenser is jammed.	<ul style="list-style-type: none"> <li>• Ice has melted and frozen around auger due to infrequent use, temperature fluctuations, and/or power outages.</li> <li>• Ice cubes are jammed between ice maker and back of ice container.</li> <li>• Ice cubes are frozen together.</li> <li>• Ice cubes are hollow or smaller than normal.</li> </ul>	<ul style="list-style-type: none"> <li>• Remove ice container, thaw, and empty the contents. Clean container, wipe dry, and replace in proper position. When new ice is made, dispenser should operate.</li> <li>• Remove ice cubes that are jamming the dispenser.</li> <li>• Use the dispenser often so that cubes do not freeze together.</li> <li>• The ice &amp; water filter cartridge could be clogged. Replace the filter cartridge. Dispensing system operates best at 30-100 psi water pressure. Well water pressures should fall within this range.</li> </ul>

**Water Dispenser**

<b>Concern</b>	<b>Cause</b>	<b>Solution</b>
Dispenser will not dispense water.	<ul style="list-style-type: none"> <li>• Water supply is not connected.</li> <li>• Household water line to the refrigerator is kinked.</li> <li>• Household water line valve is not open.</li> <li>• Freezer door is not closed.</li> <li>• Ice &amp; water filter cartridge is clogged.</li> <li>• Front filter not fully installed, if equipped</li> </ul>	<ul style="list-style-type: none"> <li>• Connect water supply (see <b>Connecting The Water Supply</b> section).</li> <li>• Unkink the water line. If it is a copper line, it should be replaced because of possible leaks at the kink. A copper line should be coiled behind the unit to avoid kinking.</li> <li>• Open household water line valve. See <b>Problem</b> section <i>Ice Maker Is Not Making Ice</i>.</li> <li>• Ensure that freezer door is closed. (See <b>Problem</b> Section, <i>Opening/Closing of Doors/Drawers</i>)</li> <li>• Replace filter cartridge.</li> <li>• Push filter in until you hear two “clicks”. Filter should be flush with the plastic housing.</li> </ul>
Water has an odd taste and/or odor.	<ul style="list-style-type: none"> <li>• Water has been in the tank for a period of time.</li> <li>• Unit not properly connected to cold water line.</li> <li>• Tubing used in the household water supply and installation may affect water taste and odor.</li> <li>• Water has a high mineral content.</li> </ul>	<ul style="list-style-type: none"> <li>• Draw and discard 10-12 glasses of water to freshen the supply and completely rinse out the tank.</li> <li>• Connect unit to cold water line that supplies water to the kitchen faucet.</li> <li>• For best results, use copper tubing for water connections.</li> <li>• Contact water treatment plant for help in checking water supply source.</li> </ul>
Water dispenses slowly.	<ul style="list-style-type: none"> <li>• Cut-off and cut-on pressures are too low (well systems only).</li> <li>• Reverse osmosis system is in regenerative phase.</li> <li>• The Ice &amp; Water filter is clogged.</li> </ul>	<ul style="list-style-type: none"> <li>• Have someone turn up the cut-off and cut-on pressure on the water pump system (well systems only).</li> <li>• It is normal for a reverse osmosis system to be below 20 psi during the regenerative phase.</li> <li>• Replace filter cartridge.</li> </ul>

**Odors In Refrigerator**

<b>Concern</b>	<b>Cause</b>	<b>Solution</b>
Interior is dirty.	<ul style="list-style-type: none"> <li>• Interior needs to be cleaned.</li> <li>• Food with strong odors is stored in refrigerator.</li> </ul>	<ul style="list-style-type: none"> <li>• See <b>Care &amp; Cleaning Tips</b>.</li> <li>• Cover food tightly. Turn on air filtration system. Air filter may need to be changed more frequently if foods with strong odors are routinely stored in refrigerator.</li> </ul>

**Opening/Closing Of Doors/Drawers**

<b>Concern</b>	<b>Cause</b>	<b>Solution</b>
Door(s) will not close.	<ul style="list-style-type: none"> <li>• Door was closed too hard, causing other door to open slightly.</li> <li>• Refrigerator is not level. It rocks on the floor when moved slightly.</li> <li>• Refrigerator is touching a wall or cabinet.</li> </ul>	<ul style="list-style-type: none"> <li>• Close both doors gently.</li> <li>• Ensure floor is level and solid, and can adequately support the refrigerator. Contact a carpenter to correct a sagging or sloping floor.</li> <li>• Ensure floor is level and solid, and can adequately support the refrigerator. Contact a carpenter to correct a sagging or sloping floor.</li> </ul>
Drawers are difficult to move.	<ul style="list-style-type: none"> <li>• Food is touching shelf on top of drawer.</li> <li>• Track that drawers slide on is dirty.</li> </ul>	<ul style="list-style-type: none"> <li>• Keep less food in drawer.</li> <li>• Clean drawer, runners, and tracks. See <b>Care &amp; Cleaning Tips</b>.</li> </ul>

---

## ***LED Light Is Not On***

---

<b>Concern</b>	<b>Cause</b>	<b>Solution</b>
LED light is not on.	<ul style="list-style-type: none"><li>• LED light is burned out.</li><li>• No electric current is reaching refrigerator.</li><li>• Control system has disabled lights because one or both doors were left open too long.</li></ul>	<ul style="list-style-type: none"><li>• See <i>Replacing LED Lights</i> in <b>Care and Cleaning</b> section.</li><li>• See <b>Problem</b> section, <i>Running Your Refrigerator</i>.</li><li>• Close and reopen door(s) to enable lights.</li></ul>

 **Electrolux**

