

Installation Instructions

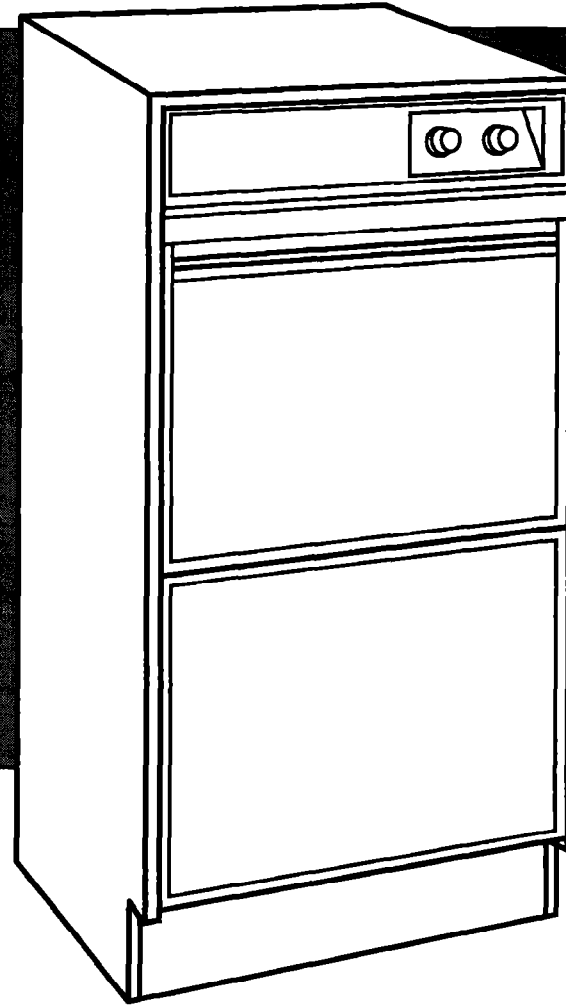

Part No. 2180911

IMPORTANT:
Read and save
these instructions.

IMPORTANT:

Installer: Leave Installation Instructions with the homeowner.

Homeowner: Keep Installation Instructions for future reference.

Save Installation Instructions for local electrical inspector's use.

**Automatic
Ice Maker**

Before you start...

⚠ WARNING



Electrical Shock Hazard

Contact a qualified electrical installer.

Assure that the electrical connection is adequate and in conformance with the National Electrical Code ANSI/NFPA 70 — latest edition* and all local codes and ordinances.

Check that electrical wiring and components Do Not contact any plumbing material or drain hose.

Check that electrical wiring, water supply line and drain line Do Not contact any exposed terminals of the ice maker wiring.

Check that electrical wiring is not routed through drain area.

Check that plumbing and electrical wiring Do Not cross in front of the ice maker motor.

Install the ice maker in a cabinet that completely encloses the sides, top and rear of the ice maker.

Failure to follow these instructions could result in death or serious injury.

It is the customer's responsibility to:

Observe all governing codes and ordinances.

- Comply with the installation specifications and dimensions provided.
- Properly install the ice maker.
- Make sure you have everything necessary for correct installation.
- Contact a qualified installer to assure that the plumbing and electrical installations are adequate and meet all national and local codes and ordinances.
- Provide a properly grounded outlet (See "Electrical requirements.")
- Provide proper water supply line and floor drain or drain pump, as specified. (See "Water requirements" and "Drain requirements.")

Plumbing and electrical wiring should not cross in front of the motor. Electrical wiring should not be routed through the drain area.

Read and follow the "Electrical requirements," "Water requirements," and "Drain requirements," before installing the ice maker.

The ice maker may be enclosed around the sides, top and rear. (See "Built-in opening dimensions.") **Do Not block or close in the front of the ice maker.** The ice maker cannot work properly if the airflow to the front of the ice maker is blocked.

Drain system requires either a gravity floor-drain system or a drain pump (see "Drain requirements") to lift the water to an existing drain. A 1-1/4" minimum diameter standpipe or 5/8" I.D. minimum drain tube to an open drain is required.

Commercial installation sanitation codes: National Sanitation Foundation (NSF) installation procedures require sealing the ice maker to the floor with approved caulking compound. We recommend using a silicone-type sealer.

Shipboard installations require a water deflector (available from your local dealer or parts distributor). Install deflector according to the instructions provided with the deflector kit. The deflector keeps the water that flows over the evaporator from spilling into the storage bin area.

Custom wood panels: The bin door and lower panel can be customized to match your wood cabinets. See "Changing the bin door and lower panel", Panel C.

When moving ice maker, slide ice maker onto cardboard or hardboard to prevent damaging floor covering.

Copies of the standard listed may be obtained from:

* National Fire Protection Association
Batterymarch Park
Quincy, Massachusetts 02269

Tools & materials needed

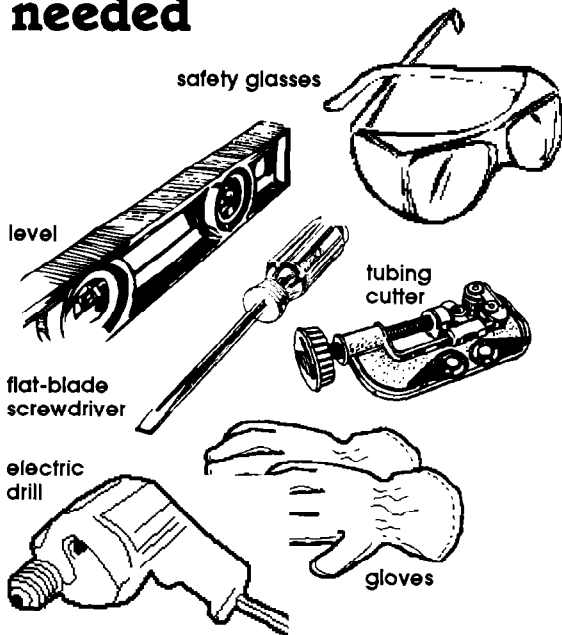

Not shown:

bucket, sponge, baking soda

1-1/4" min. diameter standpipe or 5/8" I.D. minimum drain tube

1/4" O.D. soft copper tubing

Product dimensions

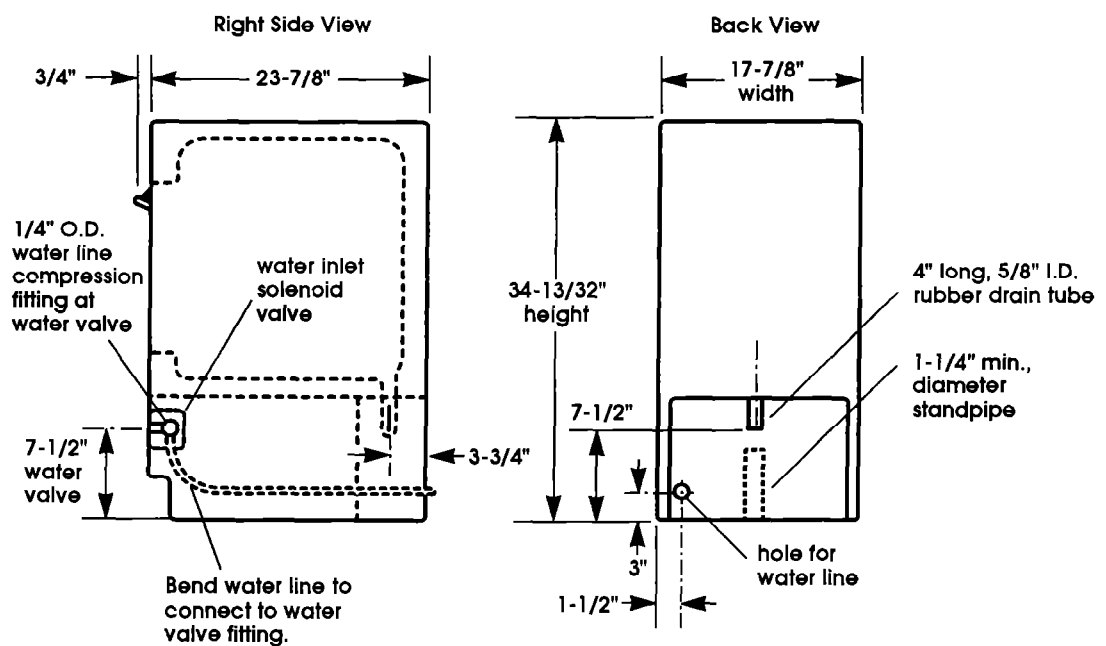

Built-in opening dimensions

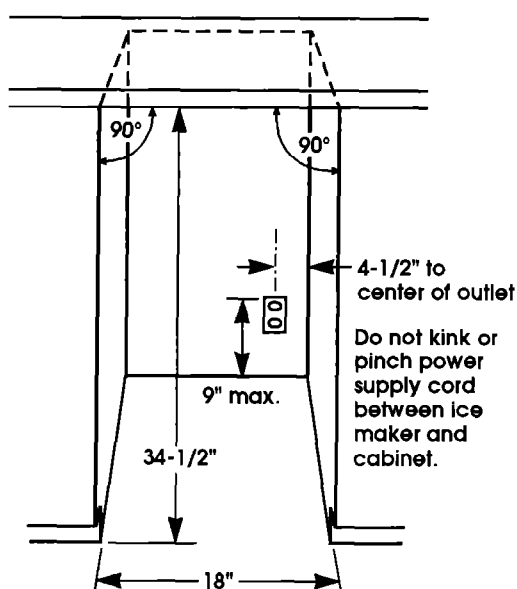

Check the location where the ice maker will be installed. The location must provide:

- Easy access to water, electricity and drain lines.
- Protection from wind, weather, dripping or spraying water and other harmful elements. **Do Not store or operate the ice maker below 55°F or above 100°F.** For best results, operate the ice maker at temperatures between 70°F to 90°F.
- Protection so the water inlet and drain lines cannot freeze.
- Good ventilation and unobstructed air flow to the front of the ice maker. **Do Not close in the front of the ice maker.** The ice maker cannot work properly if the airflow to the front of the ice maker is blocked.
- Room to fully open the ice maker door.
- Room to move the cabinet forward for servicing, if necessary.

Electrical requirements

⚠ WARNING



Electrical Shock Hazard

Electrical ground is required.
Do Not ground to a gas supply pipe.
Do Not change the power supply cord plug. If it does not fit the outlet, have a proper outlet installed by a qualified electrician.
Do Not have a fuse in the neutral or grounding circuit.
Check with a qualified electrician if you are not sure the ice maker is properly grounded.
Electrical wiring, water supply line and drain line must not contact any exposed terminals of the ice maker wiring.
Failure to follow these instructions could result in death or serious injury.

If codes permit and a separate grounding wire is used, it is recommended that a qualified electrician determine that the grounding path is adequate.

A 120-volt, 60-Hz, AC-only, 15- or 20-ampere, fused, electrical supply is required. Time-delay fuse or circuit breaker is recommended. It is recommended that a separate circuit serving only this ice maker be provided.

Recommended grounded method

For your personal safety, this appliance must be grounded. This appliance is equipped with a power supply cord having a 3-prong grounding plug. To minimize possible shock hazard, the cord must be plugged into a mating 3-prong grounding-type wall receptacle, grounded in accordance with National Electrical Code, ANSI/NFPA 70-latest edition (* see Panel A) and all local codes and ordinances. If a mating wall receptacle is not available, it is the personal responsibility and obligation of the customer to have a properly grounded, three-prong wall receptacle installed by a qualified electrician.

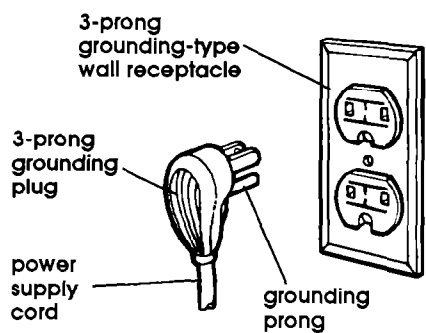

Water requirements

The cold water line to the ice maker must be 1/4" O.D. soft copper tubing. Use the threaded compression fitting to connect the water line to the ice maker inlet valve. Install a shutoff valve in the water line where it can be easy to access.

Preparation steps:

1. Put on safety glasses and gloves.
2. Cut a 1/2" minimum hole in cabinet wall or floor for water line. Right side of wall is easiest location.
3. Rough water supply tubing from the cold water supply line to cabinet opening.
4. Place water supply tubing in center of the opening and allow enough tubing so that it extends beyond the cabinet front.
5. Install a manual shutoff valve in the water line where it can be easily used.
6. Flush the water line into a bucket to get rid of any particles that may clog the inlet valve. Check that there are no sharp bends or kinks in water line that could restrict water flow. Turn the shutoff valve to the "OFF" position.

Drain requirements

This appliance is equipped with a gravity drain and a 4" long, 5/8" I.D. rubber drain tube. Determine which type of drain method you need and follow preparation instructions for that method.

Recommended drain method

Install a 1-1/4" minimum diameter standpipe directly below the drain tube outlet. (See Panel A for dimensions.)

Insulate the drain line up to the drain inlet to minimize condensation on the drain tube.

Alternate drain method

If a drain connection directly below the drain tube outlet is not available, install a drain pump in the rear compartment of the ice maker. The drain pump must meet these specifications:

- It must be U.L.-listed and have a U.L.-listed, 120 VAC, 3-wire, grounded power supply cord.
- Overall maximum outside dimensions: 15" wide x 6" deep x 9-1/2" high.
- Minimum pump flow rate: 24 gallons per hour (0.4 gallons per minute) at 12 feet lift.
- Operating temperature range of 55°F to 110°F.

Now start...

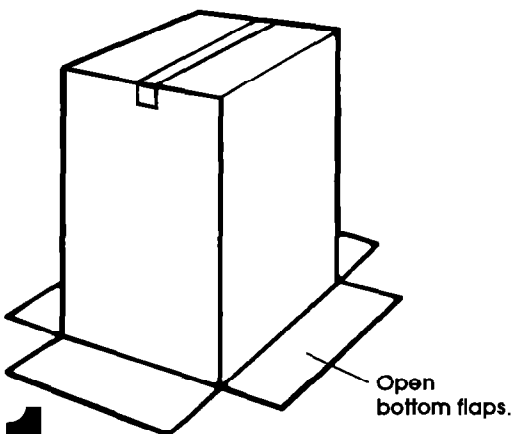

1. Carefully place carton on its side. Open bottom flaps. Set carton upright with bottom flaps folded outward. Remove carton from ice maker.

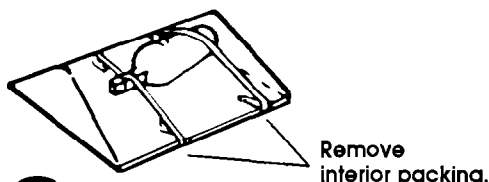

2. Remove all tape and packing material from outside and inside the ice maker. Remove parts package from inside the ice maker bin.

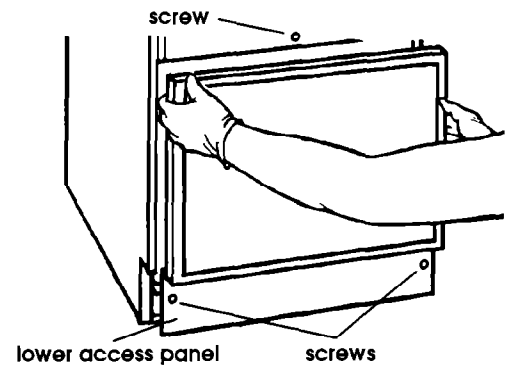

3. Remove the two screws in the lower grille area and the one screw from the center of the front panel support. Pull forward and down to remove the lower access panel.

4. Turn the fan by hand to check that it moves freely.

5. Slightly loosen, **Do Not remove**, the thumb screws holding the cutter grid and water pan in place.

Slide ice maker onto cardboard/hardboard before moving across the floor to prevent damage to the floor covering.

6. Move ice maker close to its final position. Remove the cardboard/hardboard from underneath ice maker.

⚠ WARNING



Electrical Shock Hazard

Disconnect power supply at circuit breaker or fuse box.
Failure to follow this instruction could result in death or serious injury.

7. Plug power supply cord into grounded outlet.

8. Insert the cold water supply tubing through the hole in the rear of the ice maker. Slide the ice maker into final position. Center the ice maker in the opening.

9. Bend the cold water supply tubing up toward the fitting. Attach the water supply tubing to the cold water inlet valve using the threaded compression fitting. Check for good fit.

10. Check that ice maker is level from the front to back and side to side. The ice maker must be level for proper operation.

If necessary, shim the ice maker with masonite or any hard, permanent material so that it is level and held tightly in place. If local codes require, seal ice maker cabinet to floor with an approved caulking compound.

11. If the ice maker is installed above 2,000 feet altitude, you must adjust the bin and evaporator thermostats. Remove the thermostats and follow the directions on each thermostat label for adjusting the thermostats. Reinstall the thermostats.

12. If installing decorative wood panels on the door and lower panel, follow the "Changing the bin door and lower panel" instructions.

13. Turn on the water supply and check for leaks. Then turn on the electrical supply.

14. Reattach the lower access panel and air grille assembly.

15. Check that all parts have been installed and that no steps were skipped. Check that you have all the tools you started with.

16. Take a few minutes to read the "How your ice maker works" and "Things to remember" sections, Panel C, and the Use and Care Guide to fully understand your new ice maker.

Preparing the ice maker for use:

17. Open the ice maker door. Wash out the interior bin with a solution of two tablespoons baking soda and one quart water. Rinse the bin thoroughly with water.

18. Turn the ice maker control knob to the "CLEAN" position. Check that the pump motor is operating correctly.
Note: **Only** the pump motor operates in the "CLEAN" setting.

Check the operation:

Before running your ice maker for the first time, note the following:

- Water enters only during the harvest cycle so the first harvest cycle will be completed **without** water in the system.
- Water will not enter the pump pan until the freezing plate gets cold and the ice maker begins a harvest cycle.
- Once the ice maker has been operating for a while, a normal harvest cycle takes between 1 to 2 minutes to complete. However, **the initial run takes approximately three hours to produce ice.**
- The evaporator thermostat opens when the evaporator reaches the preset temperature (+10°F to -3°F, depending on the thickness of the ice). The hot gas solenoid and the water valve solenoid are energized at this time and the pump motor and fan motor will shut down. The motors will remain off and the solenoids will remain charged until the evaporator reaches 38°F (± 2°F) again.
- **Ice maker must run at least 24 hours before adjusting the thickness setting.**

19. Turn the control knob to "ON" position. Check that the condenser fan is revolving.

Ice maker must run for three hours before ice will form.

20. Let the ice maker run for three hours. When water flows over the freezing plate, check that it is flowing evenly. If it is not, the ice maker is not level and Step 10 should be repeated.

21. Continue to let the ice maker run for 24 hours. Then check to see if the cubes are the desired thickness. If necessary, adjust the thickness control.

Changing the bin door and lower panel

The bin door and lower panel can be customized to match wood cabinets. Check your type of ice maker (Model A or B) to determine the height needed for the bin door. Only those models with a solid lower panel and toe space grille can be fitted with a lower wood panel.

- Cut panels using the specified dimensions.
- Make sure wood grain matches the direction of cabinet wood grain.
- The ice maker is subject to some humidity. Cover both sides and edges of wood panels with moisture-resistant sealer.

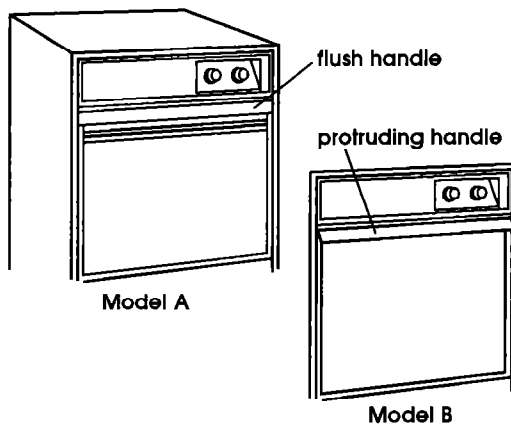

Wood panel dimensions

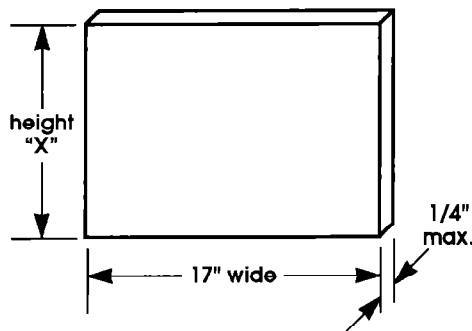

"X" Dimension	Bin Door	Lower Panel
Model A	11-1/4"	11-15/16"
Model B	13-3/16"	11-15/16"

! WARNING

Injury Hazard

Wear gloves and handle metal panels carefully.
Cut metal panel edges are sharp and may cause injury.

To change bin door panel:

1. Open bin door and remove two screws attaching handle to top of door. Remove handle.
2. Slide metal panel out of bin door.
3. Break off the ribs on the door insulation.

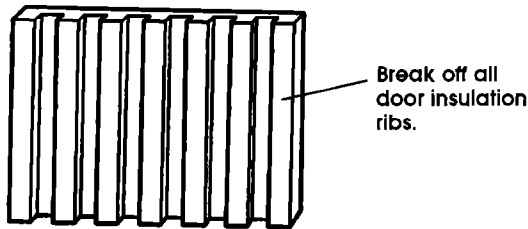

4. Slide the wood door panel into the bin door frame.
5. Reattach the handle with the two screws.

To change lower panel:

1. Remove three screws attaching lower panel assembly to ice maker. Remove two screws at top of lower panel assembly.
2. Slide metal panel and spacer panels out of lower panel assembly. Set spacer panels aside.
3. Slide metal panel back into the lower panel assembly. Slide wood panel in front of the metal panel.
4. Reinstall the two screws at the top of the lower panel assembly. Reattach the lower panel assembly to the ice maker.

How your ice maker works

When the ice maker is turned to "ON":

- Compressor and condenser fan both run.
- Water pump circulates water.
- Cutter grid becomes warm to touch.

When the ice slab reaches the desired thickness:

- Harvest cycle begins (normal harvest takes 1 to 2 minutes).
- Evaporator thermostat is satisfied.
- Compressor keeps running but the condenser fan will stop turning or turns very slowly.
- Water pump stops.
- Hot gas solenoid and water inlet valve open.
- Excess water is flushed out of the drain pan.
- Cutter grid remains warm to touch.

After the ice slab is released:

- Cycle begins again.
- Cutting process begins.

When the storage bin is filled:

- Bin thermostat opens.
- Cutter grid remains on.

Things to remember

- The ice maker will automatically continue to harvest ice until the storage bin is full.
- The ice maker will shut down when the ice in the storage bin touches the bin thermostat well. It will begin harvesting ice again when ice is removed from the bin.
- The storage bin is not refrigerated, so there will be some melting. This will vary with the temperature of the room where the ice maker is located.
- The ice maker must have good ventilation to work properly. **Do Not block the front of the ice maker.** Keep the front air grille and condenser clean.
- The water system, including the filter screen in the water solenoid valve, needs to be cleaned periodically for good circulation. Instructions for cleaning the water system are located on the inner door panel.
- As the temperature of the room and water varies, so will the amount of ice produced. Higher operating temperatures will result in less ice made. To make the most ice, set the thickness control to produce 1/2" to 5/8" thick cubes.

If the ice maker does not operate:

- √ Check that the circuit breaker is not tripped or the house fuse is intact and tight.
- √ Check that the power supply cord is plugged into the wall receptacle.
- √ Check that the water line is turned on.
- √ See the Use and Care Guide troubleshooting list.

If you need assistance:

If you have questions about operating, cleaning or maintaining your ice maker:

- √ Refer to the Use and Care Guide.
- √ Call the dealer from whom you purchased this ice maker. The dealer is listed in the Yellow Pages of your telephone directory under "Appliances — Household — Major — Service and Repair."

If you need service:

Maintain the quality built into your ice maker by calling an authorized service company.

To obtain the name and telephone number of an authorized service company:

- √ Contact the dealer from whom you purchased your ice maker; or
- √ Look in the Yellow Pages of your telephone directory under "Appliances — Household — Major — Service and Repair."

When you call, you will need:

- √ The ice maker model number.
- √ The ice maker serial number.

Both numbers can be found on the model/serial rating plate located behind the bin door on the frame.

Wiring diagram

! WARNING



Electrical Shock Hazard

Disconnect ice maker from electrical supply before servicing ice maker. Failure to follow this instruction could result in death or serious injury.

This appliance operates at 115 volts; except for the cutter grid circuit, which operates at 8.5 volts at 1 amp.

The compressor will remain running until the bin thermostat becomes satisfied and opens up. This de-energizes all the system except for the transformer and cutter grid.

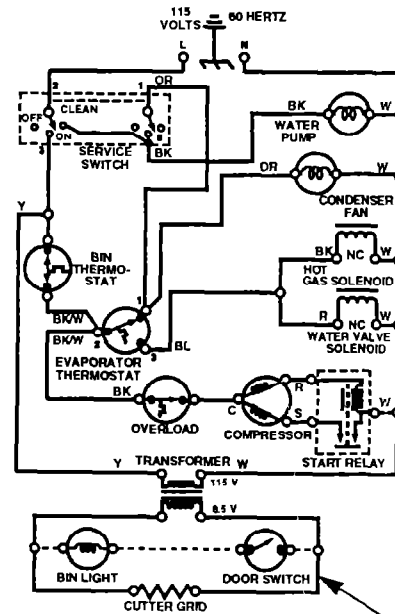

A 15- or 20-ampere time-delay fuse or circuit breaker is recommended.

NOTE: Contacts are shown in freezing cycle.

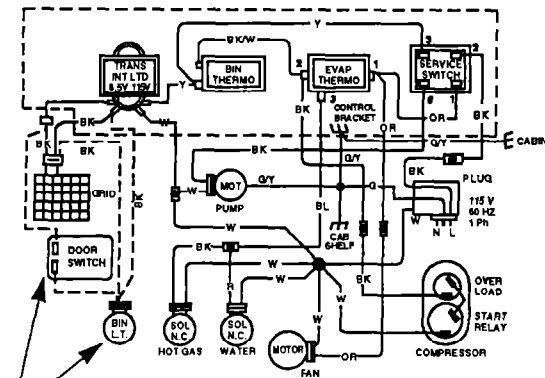

COLOR CHART	
R	RED
BK	BLACK
W	WHITE
Y	YELLOW
OR	ORANGE
BK/W	BLACK/WHITE TRACER
G/Y	GREEN/YELLOW TRACER

Note: Door switch and bin light not used on all models.