

---

# Contents

## Owner's Guide

<b>2</b>	Your Owner's Guide
<b>2</b>	Energy Saving Ideas
<b>3</b>	Important Safety Instructions
<b>4</b>	First Steps
<b>5</b>	Setting the Temperature Control
<b>5-6</b>	Freezer Optional Features
<b>6-7</b>	Care and Cleaning
<b>7</b>	Power Failure/Freezer Failure
<b>8-9</b>	Avoid Service Checklist
<b>10</b>	Warranty

## Freezer Tips

<b>11</b>	Introduction
<b>12-13</b>	Packaging
<b>14-17</b>	Baked Goods
<b>18-19</b>	Dairy Products
<b>20-23</b>	Fruits
<b>24-31</b>	Meats
<b>32-35</b>	Prepared and Cooked Foods
<b>36-37</b>	Soups, Salads, Sandwiches
<b>38-41</b>	Vegetables
<b>42</b>	More Foods to Freeze
<b>42</b>	Foods Not Recommended for Freezing
<b>43</b>	Retail Cuts of Beef
<b>44</b>	Retail Cuts of Pork

---

## Your Owner's Guide

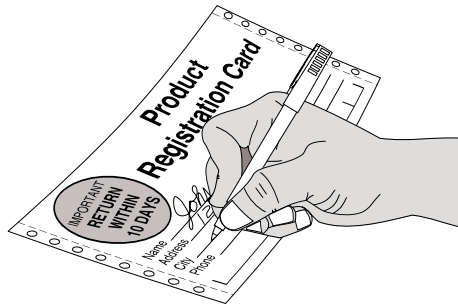

The information in this Owner's Guide will instruct you on how to properly operate and care for your product. The Freezer Tips Section will help you produce favorable results when freezing food. Please read through the information contained in your literature pack, to learn more about your new appliance.

### Record Your Model and Serial Numbers

Record the Model No. and Serial No. of this freezer in the spaces provided below.

Model No. \_\_\_\_\_

Serial No. \_\_\_\_\_

### Register Your Product

The self-addressed PRODUCT REGISTRATION CARD (shown left) should be filled in completely, signed, and returned to Electrolux Home Products.

---

## Energy Saving Ideas



- The freezer should be located in the coolest area of the room, away from heat producing appliances or heating ducts, and out of direct sunlight.
- Let hot foods cool to room temperature before placing in freezer. Overloading the freezer forces compressor to run longer. Foods that freeze too slowly may lose quality, or spoil.
- Be sure to wrap foods properly, and wipe containers dry before placing them in the freezer. This cuts down on frost build-up inside freezer.
- Freezer shelves should not be lined with aluminum foil, wax paper, or paper toweling. Liners interfere with cold air circulation, making the freezer less efficient.
- Organize and label food to reduce door openings and extended searches. Remove as many items needed at one time, and close door as soon as possible.

# Important Safety Instructions

## **⚠️ WARNING** Proper Freezer Disposal

**IMPORTANT:** Child entrapment and suffocation are not problems of the past. Junked or abandoned freezers are still dangerous— even if they will sit for “just a few days.” If you are getting rid of your old freezer, please follow the instructions below to help prevent accidents.

### **BEFORE YOU THROW AWAY YOUR OLD FREEZER:**

- \*Remove doors.
- \*Leave shelves in place so children may not easily climb inside.

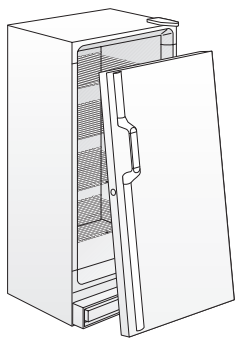

**⚠️ WARNING** Avoid fire hazard or electric shock. Do not use an extension cord or an adapter plug. Do not remove any prong from the power cord.

Grounding type wall receptacle

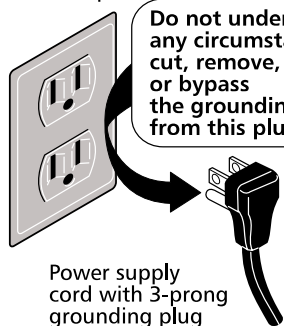

**Do not under any circumstances cut, remove, or bypass the grounding prong from this plug.**

Power supply cord with 3-prong grounding plug

Read all instructions before using this freezer.

## **⚠️ WARNING** For Your Safety

Do not store or use gasoline or other flammable vapors and liquids in the vicinity of this or any other appliance. Read product labels for flammability and other warnings.

## **⚠️ WARNING** Child Safety

- Destroy carton, plastic bags, and any exterior wrapping material immediately after freezer is unpacked. Children should never use these items for play. Cartons covered with rugs, bedspreads, plastic sheets or stretch wrap may become airtight chambers, and can quickly cause suffocation.
- A child might suffocate if he crawls into a freezer to hide or play. Remove the freezer door when not in use, even if you plan to discard the freezer. Many communities have laws requiring you to take this safety precaution.
- Remove and discard any spacers used to secure the shelves during shipping. Small objects are a choke hazard to children.

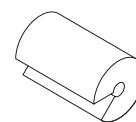

## **⚠️ WARNING** Electrical Information

*These guidelines must be followed to ensure that safety mechanisms in the design of this freezer will operate properly.*

- **Refer to serial plate for correct electrical rating.** The power cord of the appliance is equipped with a three-prong grounding plug for protection against shock hazards. It must be plugged directly into its own properly grounded three-prong receptacle, protected with a 15 amp time delay fuse or circuit breaker. The receptacle must be installed in accordance with the National Electrical Code, and local codes and ordinances. Consult a qualified electrician. Receptacles protected by Ground Fault Circuit Interrupters (GFCI) are NOT RECOMMENDED. **DO NOT use an extension cord, or an adapter plug.**
- If voltage varies by 10 percent or more, freezer performance may be affected. Operating freezer with insufficient power can damage the motor. Such damage is not covered under the warranty. If you suspect your household voltage is high or low, consult your power company for testing.
- To prevent freezer from being turned off accidentally, do not plug the unit into an outlet controlled by a wall switch, or the pull cord.
- Do not pinch, knot, or bend power cord in any manner.

## **⚠️ WARNING** Other Precautions

- Never unplug freezer by pulling on the power cord. Always grip the plug firmly, and pull straight out from receptacle.
- Turning the control to OFF turns off the compressor, but does not disconnect power to other electrical components.

## First Steps

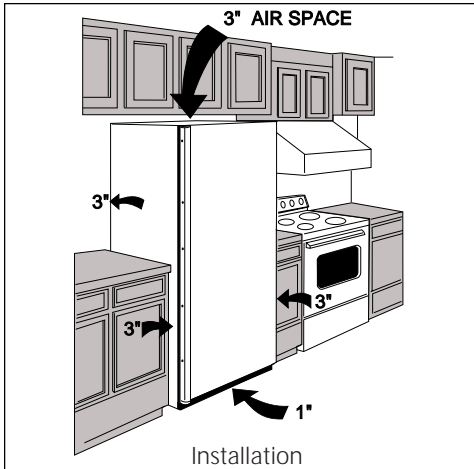

Before starting the freezer, follow these important first steps:

### Installation

- Choose a place that is near a grounded electrical outlet.
- For the most efficient operation, freezer should be located where surrounding temperatures will not exceed 110°F (43°C). Temperatures of 32°F (0°C) and below will NOT affect freezer operation. Additional compressor heaters are not recommended.
- *Allow space around the unit for good air circulation.* Leave a 3 inch (75 mm) space on all sides of freezer, for adequate circulation.

### Leveling

Freezer must have all bottom corners resting firmly on a solid floor. The floor must be strong enough to support a fully loaded freezer. Check the cabinet with a level from side to side. After discarding crating screws and wood base, level the freezer cabinet.

Once leveled, slightly raise adjustment of front feet, so door closes easily when opened about halfway.

### Cleaning

- Wash any removable parts, and the interior and exterior with mild detergent and warm water. Wipe dry. **Do not use harsh cleaners on these surfaces.**
- Do not use razor blades or other sharp instruments, which can scratch the appliance surface when removing adhesive labels. Any glue left from tape or energy label can be removed with a mixture of warm water and mild detergent, or touch the residue with the sticky side of tape already removed. **Do not remove serial plate.**

### Upright Freezer Door Removal:

*If door must be removed:*

1. Lift up plastic hinge cover, and fold back.
2. Use a Phillips® screwdriver to loosen and retighten screws on the top hinge, to ensure a secure assembly, and prevent hinge slippage.
3. Remove top hinge from cabinet, and lift door off the lower hinge pin.
4. After door is removed, remove the two screws from bottom hinge.
5. To replace door, reverse above order.

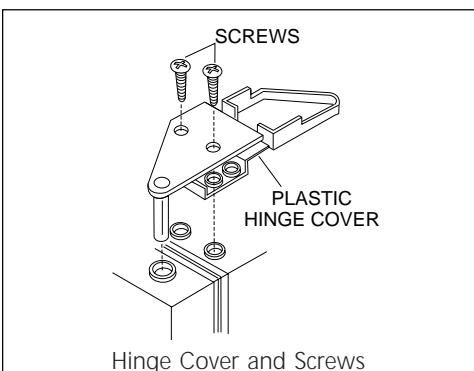
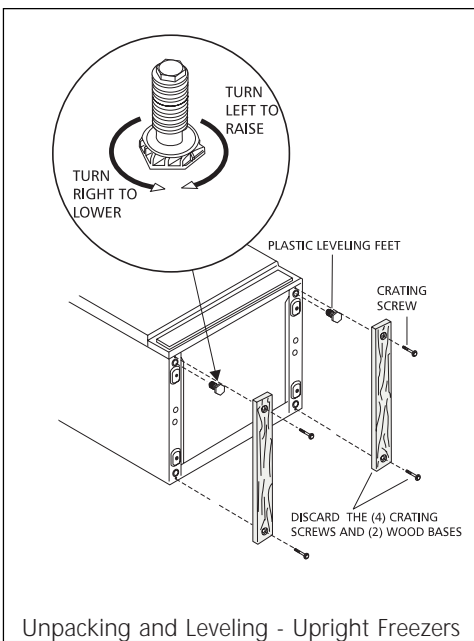

## Setting the Temperature Control

### Cool Down Period

- For safe food storage, allow 4 hours for freezer to cool down completely. Freezer will run continuously for the first several hours. Foods that are already frozen may be placed in freezer after the first few hours of operation. Unfrozen foods should NOT be loaded into freezer until freezer has operated for 4 hours.
- When loading freezer, freeze only 3 pounds of fresh food per cubic foot of freezer space at one time. Evenly distribute packages to be frozen throughout freezer. It is not necessary to turn control knob to a colder setting while freezing food.

### Temperature Control

The temperature control is located inside the freezer compartment. The temperature is factory preset to provide satisfactory food storage temperatures. However, the temperature control is adjustable to provide a range of temperatures for your personal satisfaction. If a colder temperature is desired, turn the temperature control knob toward COLDEST and allow several hours for temperatures to stabilize between adjustments.

## Freezer Optional Features

Your freezer may have some, or all of the features listed below. Become familiar with these features, and their use and care.

### Power On Light

The Power On Light indicates that the freezer is properly connected to electrical power. The light glows even when the temperature control is turned to OFF. If the light goes out, refer to "Freezer does not run" section in the Avoid Service Checklist.

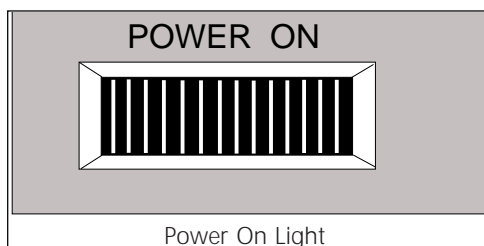

### Temp Alarm

This feature is designed to provide warning of a possible malfunction. The Temp Alarm Switch is located in the base panel. This feature operates on household electricity. If power fails, the alarm will not perform. The ON/OFF Switch allows you to turn off Temp Alarm when not wanted.

The freezer is shipped with Temp Alarm in the OFF position. After freezer has run long enough to lower the temperature, activate Temp Alarm by pressing eraser end of a pencil into the hole marked ON, moving the rocker switch. To turn off alarm, depress the OFF Switch. The Temp Alarm should be turned to the OFF position when defrosting freezer.

If alarm sounds, be sure freezer is properly leveled, and the door closes freely and seals properly. If a technical problem is suspected, call an authorized servicer immediately.

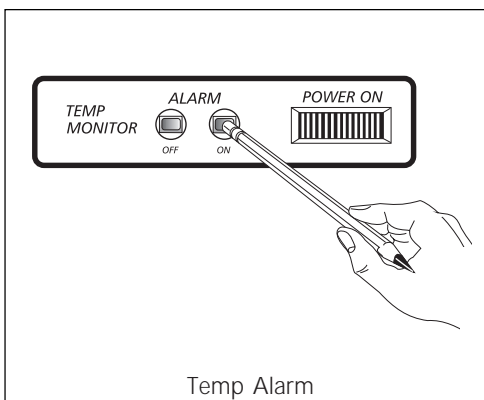

### Super Freeze

When the Super Freeze Switch is ON, freezer will run continuously to reach the coldest possible temperatures. Use this feature prior to adding large quantities of unfrozen foods. (Not to exceed 3 pounds per cubic foot of freezer space.) This switch must be manually returned to the OFF position when not needed.

### Super Defrost

Note: The Temp Alarm should be turned off when freezer is being defrosted. Freezer will defrost in a fraction of the time usually needed when using Super Defrost feature. To defrost, **remove all food**, and follow these steps:

1. Pull out Super Defrost Switch, located behind lower part of door. Leave door open while defrosting. Freezer will not defrost with door closed.
2. After defrosting is completed, push in Super Defrost button to restart compressor,
3. Turn on Temp Alarm after freezer has reached freezing temperatures.

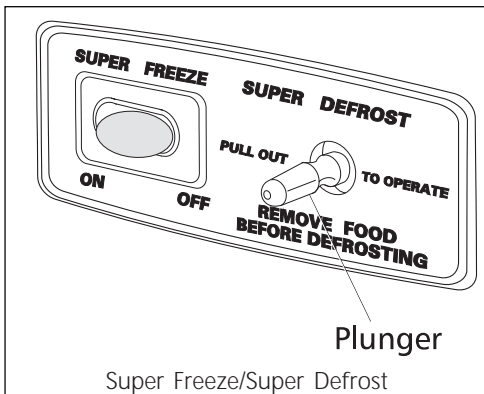

## Freezer Optional Features (continued)

### Slide-Out Basket

The Slide-Out Basket, located at the bottom of the freezer provides separate storage space for items that are difficult to store on freezer shelves. To remove basket, pull out and lift up.

### Juice Can Rack

The Juice Can Rack on the freezer door is specially ridged to store juice cans, and prevent them from rolling out of the shelf.

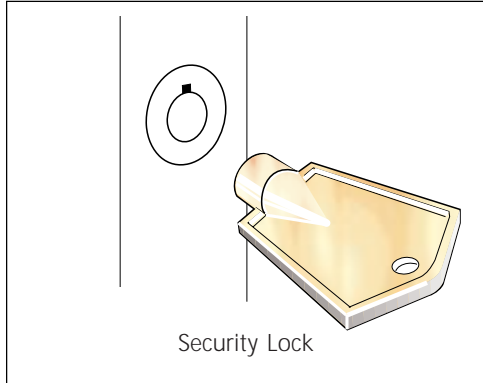

### Security Lock with Pop-Out Key

This security lock fastens the door snugly, ensuring stored food is secure. To lock or unlock freezer, push key into the lock, and turn. The key pops out of the lock after it has been turned.

### Interior Light

The light comes on automatically when the door is opened. To replace light bulb, turn temperature control to OFF, and unplug electrical cord. Replace old bulb with a bulb of the same wattage.

### Power Cord Clamp

This clamp prevents the power cord from being accidentally unplugged. Remember when removing or replacing electrical cord, to also remove or replace power cord clamp.

### Adjustable Shelf

This shelf can be moved to one of two positions. Lift shelf up and out to move to desired position.

### Defrost Drain

The Defrost Drain provides a method of draining the water during defrosting and cleaning. See "Defrosting" in the Care and Cleaning section.

### Fast Freezing Shelves

These shelves contain cooling coils to freeze foods quickly, and allow cold air to constantly circulate throughout freezer. Do not use sharp metal objects such as ice picks or scrapers to clean these shelves. This could damage shelves and reduce their cooling ability. These shelves are not adjustable.

## Care and Cleaning

### CAUTION

Damp objects stick to cold metal surfaces. Do not touch metal surfaces with wet or damp hands.

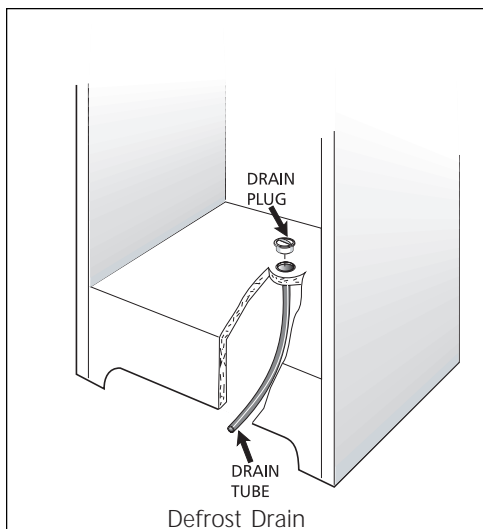

NEVER use metallic scouring pads, brushes, abrasive cleaners, or alkaline solutions on any surface.

### Between Defrostings

To avoid frequent defrosting, occasionally use a plastic scraper to remove frost. Scrape with a pulling motion. Never use a metal instrument to remove frost.

### Defrosting

It is important to defrost and clean freezer when 1/4 to 1/2 inch of frost has accumulated. Frost may tend to accumulate faster on upper part of freezer due to warm, moist air entering freezer when door is opened. Remove food and leave door open when defrosting freezer. For Super Defrost, see "Freezer Optional Features."

- **On models with a defrost drain**, remove drain plug on inside floor of freezer by pulling straight out. To access external drain tube on models with a base panel, first remove the two screws from base panel.

Locate drain tube near left center under freezer. Place a shallow pan under drain tube. Defrost water will drain out. Check pan occasionally, so water does not overflow. Replace drain plug when defrosting and cleaning are completed. Remember, if drain is left open, warm air may enter freezer.

---

## Care and Cleaning (continued)

If frost is soft, remove using a plastic scraper. If frost is glazed and hard, fill deep pans with hot water, and place them on freezer bottom. Close freezer door. Frost should soften in about 15 minutes. Repeat this procedure if necessary.

### Cleaning the Inside

Wash inside surfaces of freezer with a solution of two tablespoons of baking soda in one quart (1.136 litres) warm water. Rinse and dry. Be sure to wring excess water out of sponge or cloth when cleaning in the area of the controls, or any electrical parts.

Wash removable parts and door gasket with the baking soda solution mentioned above, or mild detergent and warm water. Rinse and dry. Do not wash removable parts in a dishwasher.

### Cleaning the Outside

Wash cabinet with warm water and mild liquid detergent. Rinse well and wipe dry with a clean soft cloth. Replace freezer parts and food.

**⚠️ WARNING** If leaving freezer door open while on vacation, make certain that children cannot get into freezer and become entrapped.

### Vacation and Moving Tips

**Short Vacations:** Leave freezer operating during vacations of one to three weeks.

**Long Vacations:** If freezer will not be used for several months, remove all food, turn temperature control to OFF, and unplug power cord. Clean and dry interior thoroughly. Leave freezer door open slightly, blocking it open if necessary, to prevent odor and mold growth.

**Moving:** Disconnect power cord plug from wall outlet. Remove foods, then defrost and clean freezer. Secure all loose items such as base panel, baskets, and shelves by taping them securely in place to prevent damage. Keep freezer door closed. In the moving vehicle, secure freezer in an upright position, and secure to prevent movement. Also protect outside of freezer with a blanket, or similar item.

---

## Power Failure/ Freezer Failure

**NOTE:** Do not open freezer door unnecessarily if power is cut off due to electrical failure.

**If a power failure occurs,** frozen foods will stay frozen for at least 24 hours if freezer is kept closed. If the power failure continues, pack seven or eight pounds of dry ice into freezer every 24 hours. Look in the Yellow Pages under "Dry Ice," "Dairies," or "Ice Cream Manufacturers" for local dry ice suppliers. Always wear gloves, and use caution when handling dry ice.

**If freezer has stopped operating,** see "Freezer does not run" in the Avoid Service Checklist of this manual. If you cannot solve the problem, call an authorized servicer immediately.

Do not open freezer door unnecessarily. If freezer remains off for several hours, follow directions above for the use of dry ice during a power failure. If necessary, take food to a local locker plant until freezer is ready to operate. Look in the Yellow Pages under "Frozen Food Locker Plants."



# Avoid Service Checklist

Before calling for service, review this list. It may save you time and expense. This list includes common occurrences that are not the result of defective workmanship or materials in this appliance.

## OCCURRENCE

## SOLUTION

### **FREEZER DOES NOT RUN**

Temperature control is in the OFF position. See *Setting the Temperature Control*.

Check to be sure freezer is NOT plugged into a circuit that has ground fault interrupt. If you are unsure about the outlet, have it checked by a certified technician.

Freezer may not be plugged in, or plug may be loose. Make sure plug is tightly pushed into electrical outlet.

House fuse has blown, or circuit breaker has tripped. Check/reset circuit breaker, or replace fuse with 15 amp. time delay fuse.

Power outage. Check house lights. Call local electric company.

### **Freezer runs too much, or too long.**

Room or outside weather is hot. It is normal for freezer to work harder under these conditions.

Freezer had recently been disconnected for a period of time. Freezer requires 4 hours to cool down completely.

Large amounts of warm or hot food have been stored recently. Warm food will cause freezer to run more, until desired temperature is reached.

Door is kept open too long, or too frequently. Warm air enters the freezer every time door is opened. Open door less often.

Freezer door may be slightly open. See Occurrence section "Door Problems."

Temperature control is set too cold. Turn control knob to a warmer setting. Allow several hours for temperature to stabilize.

Freezer gasket is dirty, worn, cracked, or poorly fitted. Clean or change gasket. Leaks in door seal will cause freezer to run longer in order to maintain desired temperature.

### **Temperatures inside freezer are too cold.**

Temperature control is set too cold. Turn control to a warmer setting. Allow several hours for the temperature to stabilize.

### **Temperatures inside freezer are too warm.**

Temperature control is set too warm. Turn control to a colder setting. Allow several hours for temperature to stabilize.

Door is kept open too long or is opened too frequently. Warm air enters freezer every time door is opened. Open door less often.

Door may be open slightly. See Occurrence section "Door Problems."

Large amounts of warm or hot food may have been stored recently. Wait until freezer has had a chance to reach its selected temperature.

Freezer has recently been disconnected for a period of time. Freezer requires 4 hours to cool down completely.

### **Temperature of external freezer surface is warm.**

Exterior freezer walls can be as much as 30°F warmer than room temperature. This is normal while compressor works to remove warm air from the inside freezer cabinet.



## OCCURRENCE

## SOLUTION

### SOUND AND NOISE

---

**Louder sound levels when freezer is on.** Modern freezers have increased storage capacity and more even temperatures. They require a high speed compressor. When surrounding noise level is low, you might hear the compressor running while it cools the interior.

---

**Louder sound levels when compressor comes on.** Freezer operates at higher pressures during the start of the ON cycle. This is normal. Sound will level off, or disappear as freezer continues to run.

---

**Popping or cracking sound when compressor comes on.** Metal parts expand and contract, as do hot water pipes. This is normal. Sound will level off or disappear as freezer continues to run.

---

**Bubbling or gurgling sound, like water boiling.** Refrigerant (used to cool freezer) is circulating throughout the system. This is normal.

---

**Vibrating or rattling noise.** Freezer is not level. It rocks on the floor when it is moved slightly. Re-level freezer, or move freezer slightly. Refer to "Leveling" in *First Steps*.

---

Freezer is touching the wall. Re-level freezer, or move freezer slightly. Refer to "Leveling" in *First Steps*.

### WATER/MOISTURE/FROST INSIDE FREEZER

---

**Moisture forms on inside freezer walls.** Door is slightly open. See Occurrence section "Door Problems."

---

Door is kept open too long, or is opened too frequently. Open door less often.

---

Weather is hot and humid, which increases internal rate of frost build-up. This is normal.

### WATER/MOISTURE/FROST OUTSIDE FREEZER

---

**Moisture forms on outside of freezer.** Door is slightly open, causing cold air from inside the freezer to meet warm moist air from outside. See Occurrence section "Door Problems."

### ODOR IN FREEZER

---

Interior needs to be cleaned. Clean interior with sponge, warm water, and baking soda.

---

Foods with strong odors are in freezer. Cover food tightly.

### DOOR PROBLEMS

---

**Door will not close.** Freezer is not level. It rocks on the floor when it is moved slightly. This condition can force the cabinet out of square, and misalign door.

### LIGHT BULB IS NOT ON

---

Light bulb is burned out. Follow directions under "Interior Light" in Freezer Features.

---

No electric current is reaching the freezer. See "Freezer Does Not Run."

# BROICH FREEZER WARRANTY

Your product is protected by this warranty

	WARRANTY PERIOD	BROICH, THROUGH ITS AUTHORIZED SERVICERS, WILL:	THE CONSUMER WILL BE RESPONSIBLE FOR:								
<b>FULL ONE-YEAR WARRANTY</b>	For one year from original purchase date.	Pay all costs for repairing or replacing any parts of this appliance which prove to be defective in workmanship or material.	Costs of service calls that are listed under <b>NORMAL RESPONSIBILITIES OF THE CONSUMER.*</b>								
<b>LIMITED 2ND -5TH YEAR WARRANTY (Sealed System)</b>	During the second through fifth years from original purchase date.	Repair or replace any parts in the Sealed Refrigeration System (compressor, condenser, evaporator, dryer and tubing) which prove to be defective in workmanship or material, and provide the labor to install such part.	Diagnostic costs and any removal, transportation and reinstallation costs which are required because of service. All costs for labor, parts and transportation other than with respect to the Sealed Refrigeration System.								
<b>LIMITED WARRANTY (Applicable to the State of Alaska)</b>	Time periods listed above.	All of the provisions of the full and limited warranties above and the exclusions listed below apply.	Costs of the technician's travel to the home and any costs for pick up and delivery of the appliance required because of service.								
<b>THREE-YEAR LIMITED FOOD SPOILAGE PLAN</b>	During the first three years from original purchase date.	<p>Broich Enterprises Inc. will reimburse the owner for actual food spoilage loss in excess of \$5.00 per occurrence, but not to exceed the maximum for three years in the schedule below, due to failures under normal personal, family, or household use, in the U.S.A., of this freezer to maintain food preserving temperature provided that the food losses:</p> <p>A) Are reported and the food shown to any Broich authorized servicer within 24 hours of the discovery of the loss.</p> <p>B) Are not occasioned by either the manual disconnection of the electrical power within the premises of the owner or a general power failure or interruption of power due to a blown fuse or circuit breaker.</p> <table style="margin-left: auto; margin-right: auto;"> <thead> <tr> <th style="text-align: center;">Size - Cubic Foot</th> <th style="text-align: center;">Cumulative Maximum</th> </tr> </thead> <tbody> <tr> <td style="text-align: center;">5-9.9</td> <td style="text-align: center;">\$100</td> </tr> <tr> <td style="text-align: center;">10.0-16.5</td> <td style="text-align: center;">\$150</td> </tr> <tr> <td style="text-align: center;">16.6+</td> <td style="text-align: center;">\$200</td> </tr> </tbody> </table>	Size - Cubic Foot	Cumulative Maximum	5-9.9	\$100	10.0-16.5	\$150	16.6+	\$200	
Size - Cubic Foot	Cumulative Maximum										
5-9.9	\$100										
10.0-16.5	\$150										
16.6+	\$200										

We authorize no person to change or add to any of our obligations under this warranty. Our obligations for service and parts under this warranty must be performed by Broich Enterprises or an authorized Broich servicer.

## NORMAL RESPONSIBILITIES OF THE CONSUMER

**This warranty applies only to products in ordinary household use, and the consumer is responsible for the items listed below:**

- Proper use of the appliance in accordance with instructions provided with the product.
- Proper installation by an authorized servicer in accordance with instructions provided with the appliance and in accordance with all local plumbing, electrical and/or gas codes.
- Proper connection to a grounded power supply of sufficient voltage, replacement of blown fuses, repair of loose connections or defects in house wiring.
- Expenses for making the appliance accessible for servicing, such as removal of trim, cupboards, shelves, etc., which are not a part of the appliance when it was shipped from the factory.
- Damages to finish after installation.
- Replacement of light bulbs and/or fluorescent tubes (on models with these features).

## EXCLUSIONS

**This warranty does not cover the following:**

- CONSEQUENTIAL OR INCIDENTAL DAMAGES SUCH AS PROPERTY DAMAGE AND INCIDENTAL EXPENSES RESULTING FROM ANY BREACH OF THIS WRITTEN OR ANY IMPLIED WARRANTY.  
*Note: Some states do not allow the exclusion or limitation of incidental or consequential damages, so this limitation or exclusion may not apply to you.*
- Service calls which do not involve malfunction or defects in workmanship or material, or for appliances not in ordinary household use. The consumer shall pay for such service calls.
- Damages caused by services performed by persons other than authorized Broich servicers; use of parts other than genuine renewal parts; obtained from persons other than such servicers; or external causes such as abuse, misuse, inadequate power supply or acts of God.
- Products with original serial numbers that have been removed or altered and cannot be readily determined.

## SERVICE

Since it is the responsibility of the consumer to establish the warranty period by verifying the original purchase date, keep your bill of sale, delivery slip, or some other appropriate payment record. This written warranty gives you specific legal rights. You may also have other rights that vary from state to state. Service under this warranty must be obtained by following these steps, in order:

- Contact the dealer where you purchased your appliance or an authorized Broich servicer.

DEALER/SERVICER: \_\_\_\_\_

INSTALLATION DATE: \_\_\_\_\_

MODEL NUMBER: \_\_\_\_\_

SERIAL NUMBER: \_\_\_\_\_

- If there is a question as to where to obtain service, write our consumer relations department at the address following:

### **BROICH ENTERPRISES**

6440 City West Parkway  
Eden Prairie, MN 55344

Product features or specifications as described or illustrated are subject to change without notice. All warranties are made by Broich Enterprises. This warranty applies only in the 50 states of the U.S.A. and Puerto Rico.