



Washer

PRODUCT MODEL NUMBERS

TAWB600E	TAWX500L
TAWB600J	TAWX700J
TAWS700E	
TAWS800J	

Electrical: 120-volt, 60-Hz, AC-only, 15- or 20-amp. electrical supply. A time-delay fuse or circuit breaker and separate circuit is recommended.

REQUIREMENTS

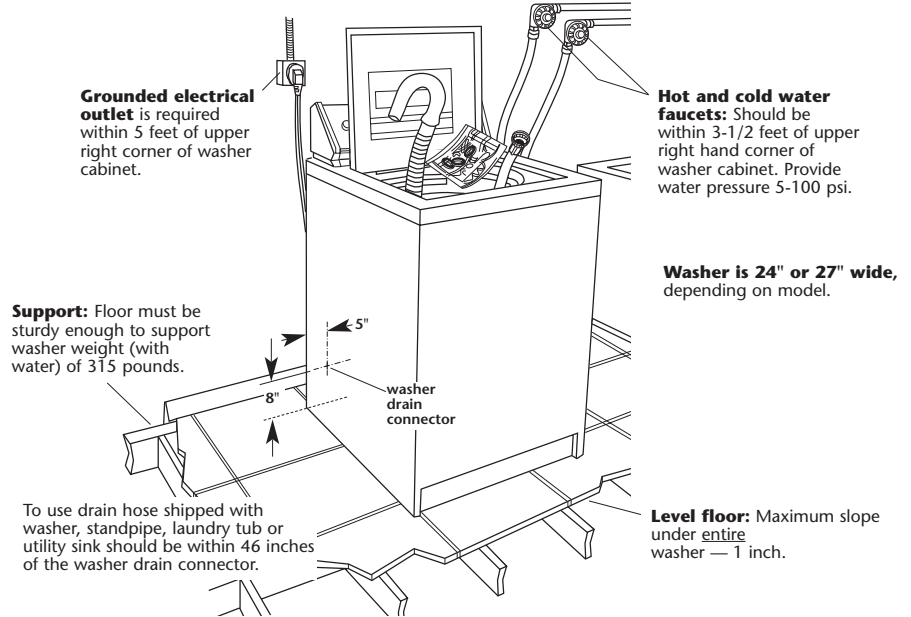

RECESSED AREA AND CLOSET INSTALLATION

Closet confined area

If a closet door is installed: The minimum unobstructed air openings are required. Louvered doors with equivalent air openings are acceptable.

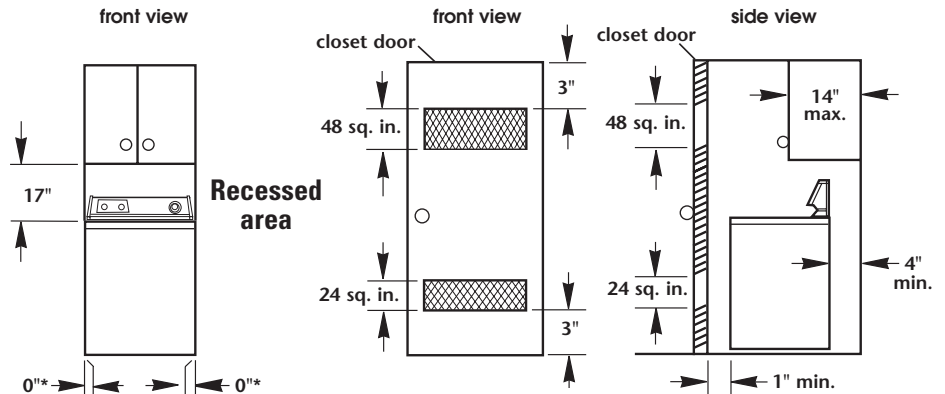

* Additional clearances for wall, door and floor moldings may be required.

DRAIN SYSTEM OPTIONS

1. Laundry tub or utility sink drain system:

Needs a 20-gallon laundry tub.

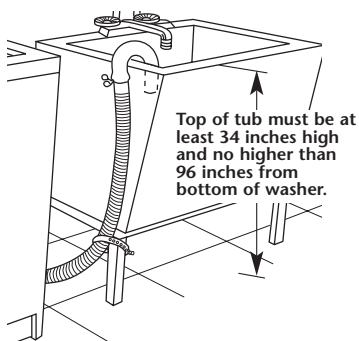

2. Floor drain system:

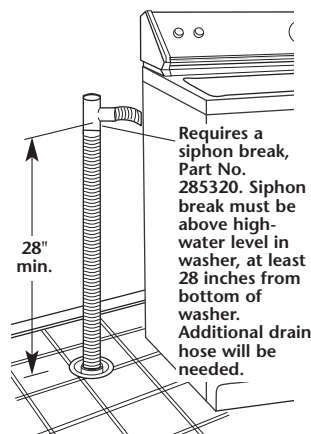

3. Standpipe drain system:

Needs a two-inch minimum diameter standpipe with minimum carry-away capacity of 17 gallons per minute. A 2" dia. to 1" dia. standpipe adapter, Part No. 3363920, must be used with 1" dia. drain systems.

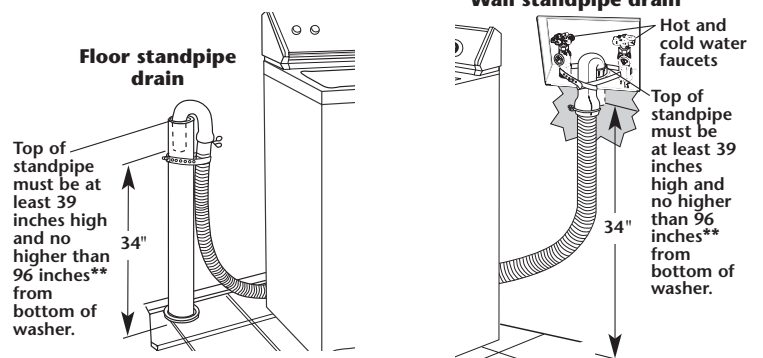

**If the drain height is greater than 96 inches, a sump pump system must be used.