

HOOVER® SteamVac™

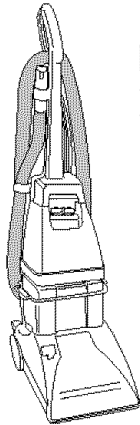

with Attached Tools



The Easy to Use
Deep Cleaner

ENGLISH → pp. 1 - 14
ESPAÑOL → pág. 15 - 28
FRANÇAIS → p. 29 - 42



Owner's Manual

Review this manual before operating deep cleaner.

Record and Retain

This HOOVER deep cleaner is designed for deep cleaning of carpet, and rugs. Some models can also be used to clean carpeted stairs and upholstery.

The model and serial numbers are located on the data label on the back of the deep cleaner handle.

For your personal records, please enter the **COMPLETE** model and serial numbers in the spaces provided and retain this information.

Your deep cleaner is model _____

and has serial number _____

It is suggested that you attach your sales receipt to this owner's manual. Verification of date of purchase may be required for warranty service of your Hoover product.

Index

Important safeguards	2
Unpacking deep cleaner.....	2
Assembling deep cleaner.....	2-5
Deep cleaner description	5
General operation	6
Filling the clean solution tank	6-7
Emptying the recovery tank.....	7-8
How to use	
Before you begin.....	8
After cleaning	9
Cleaning carpet	9
Picking up spills.....	9
Cleaning bare floors	10
Using the stair/upholstery nozzle.....	11
Cleaning carpeted stairs.....	12
Cleaning upholstery	13
If you have a problem	14
Lubrication.....	13
Service	14
Storage	13

Thank you for selecting a HOOVER product.

This cleaner was inspected and packaged carefully before being shipped from the factory. If you should happen to need assistance during assembly or operation, call

1-800-944-9200 for an automated referral of authorized service outlet locations (U.S. only) or 1-330-499-9499 (U.S.) and 1-800-263-6376 (Canada) to speak with a Hoover representative or check the Service section of The Hoover Company on-line at www.hoover.com.

PLEASE DO NOT RETURN THIS PRODUCT TO THE STORE.

Grounding Instructions

This appliance must be grounded. If it should malfunction or breakdown, grounding provides a path of least resistance for electrical current to reduce the risk of electric shock. This appliance is equipped with a cord having an equipment-grounding conductor and grounding plug (A). The plug must be plugged into an appropriate outlet (B) that is properly installed and grounded in accordance with all local codes and ordinances.

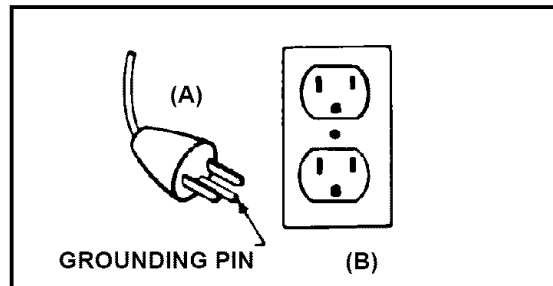

DANGER-

Improper connection of the equipment-grounding conductor can result in the risk of electric shock. Check with a qualified electrician or service person if you are in doubt as to whether the outlet is properly grounded. Do not modify the plug provided with the appliance - if it will not fit the outlet, have a proper outlet installed by a qualified electrician. This appliance is for use on a nominal 120 volt circuit and has a grounding plug that looks like the plug illustrated in sketch (A).

A temporary adapter (C) may be used to connect this plug to a 2-pole receptacle (D) if a properly grounded outlet is not available. The temporary adapter should be used only until a properly grounded outlet (B) can be installed by a qualified electrician. The green colored rigid ear, lug, or the like extending from the adapter must be connected to a permanent ground such as a properly grounded outlet box cover. Whenever the adapter is used, it must be held in place by a metal screw.

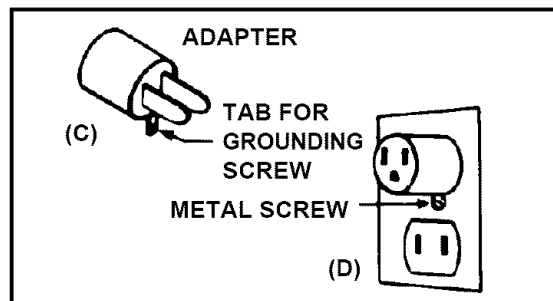

NOTE: In Canada, the use of a temporary adapter is not permitted by the Canadian Electrical Code.

© 1993, 1996 The Hoover Company
www.hoover.com

Important Safeguards!

When using an electrical appliance, always follow basic precaution, including the following:

READ ALL INSTRUCTIONS BEFORE USING THIS APPLIANCE

WARNING: To reduce the risk of fire, electric shock, or injury:

- Use indoors only.
- Use only on surfaces moistened by the cleaning process or small spills. Do not immerse product.
- Connect to a properly grounded outlet only. See "Grounding Instructions".
- Do not clean over floor electrical outlets.
- Do not use without tanks in place.
- Use extra care when cleaning on stairs. Do not place carpet cleaning machine on stairs.
- Use deep cleaner only for its intended use as described in the instructions. Use only attachments recommended by The Hoover Company; others may cause hazards.
- The use of an extension cord is not recommended. If an extension cord is absolutely necessary, use at least a 16 gauge 3-wire cord which has a 3-prong grounding type plug and a 3-pole receptacle that accepts the machine plug.
- Unplug deep cleaner when not in use. Turn off all controls before unplugging.
- Always disconnect cord from electrical outlet before servicing the deep cleaner.
- Do not unplug by pulling on cord. To unplug, grasp the plug, not the cord. Never handle plug or appliance with wet hands.
- Do not pull or carry by cord, use cord as a handle, close door on cord or pull cord around sharp edges or corners. Do not run appliance over cord. Keep cord away from heated surfaces.
- Do not use with damaged cord or plug. If appliance is not working as it should, has been dropped, damaged, left outdoors, or dropped into water, take it to a Hoover Factory Service Center or Authorized Hoover Warranty Service Dealer.
- Close supervision is necessary when any appliance is used by or near children. Do not allow deep cleaner to be used as a toy or to run unattended at any time.
- Do not point stair/upholstery tool toward people or pets.
- To assist in reducing drying time, be certain the area is well ventilated when using detergents and other cleaners with this machine.
- Keep detergents and other cleaners out of children's reach.
- Do not use to pick up flammable or combustible liquids such as gasoline or use in areas where they may be present.
- Do not pick up chlorine bleach, drain cleaner, gasoline or any other toxic material with this appliance.
- Do not pick up anything that is burning or smoking, such as cigarettes, matches, or hot ashes.
- Avoid picking up hard, sharp objects with the deep cleaner. They may damage the machine.
- Keep hair, loose clothing, fingers, feet and all parts of body away from openings and moving parts.
- Do not put any object into openings. Do not use with any opening blocked; keep free of dust, lint, hair, and anything that may reduce air flow.
- To help prevent matting and resoiling, avoid contact with carpets until they are dry. Keep children and pets away from carpets until they are completely dry.
- Store in a dry place. Do not expose machine to freezing temperatures.

Questions or Concerns?

The Hoover Company wants to quickly resolve any concerns about your cleaner or questions regarding its use. Look on the list provided with the product for your local **Hoover Factory Service Center** or in the Yellow Pages under "Vacuum Cleaners - Household" for the nearest **Authorized Hoover Warranty Service Dealer (Depot)** or call: **1-800-944-9200** for an automated referral of authorized service outlet locations (U.S. only) or 1-330-499-9499 (U.S.) or 1-800-263-6376 (Canada) to speak with a Hoover representative.

PLEASE DO NOT RETURN THIS PRODUCT TO THE STORE OR SEND IT TO NORTH CANTON FOR SERVICE.

Unpacking

Unpack deep cleaner from the carton and identify the parts shown. Remove and dispose of the packing.

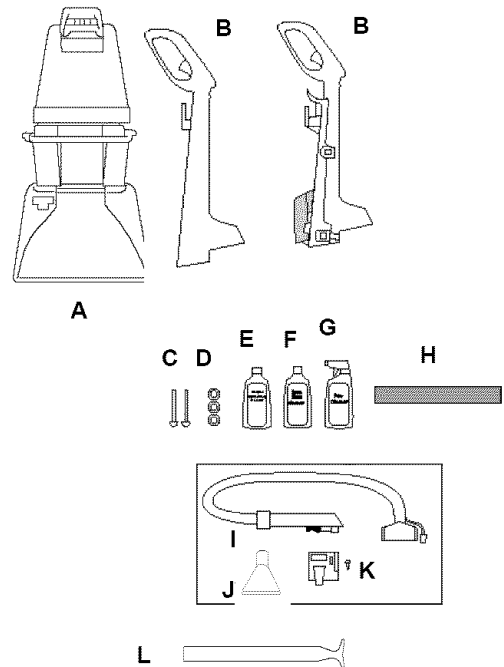

- A. Deep cleaner
- B. Upper handle OR Upper handle with hose/nozzle rack*
- C. Bolts (2)
- D. Nuts (3 - one extra included)
- E. Carpet/Upholstery Detergent
- F. Bare Floor Cleaner*
- G. PreCleaner*
- H. Bare floor attachment*
- I. Hose*
- J. Stair/upholstery nozzle*
- K. Lower hose hook and screw*
- L. Nozzle clean-out tool*

*Included with some models.

Save these instructions!

SteamVac™ Deep Cleaner cleans carpet fibers by applying hot tap water and cleaning solution.

Assembling deep cleaner

Assembled models without attached tools will look like this drawing.

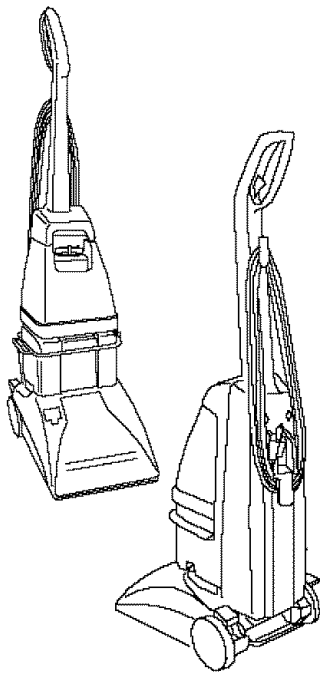

Assembled models with attached tools will look like this drawing.

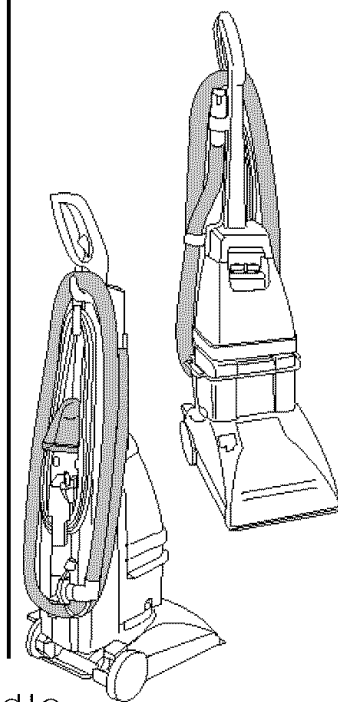

Attach upper handle

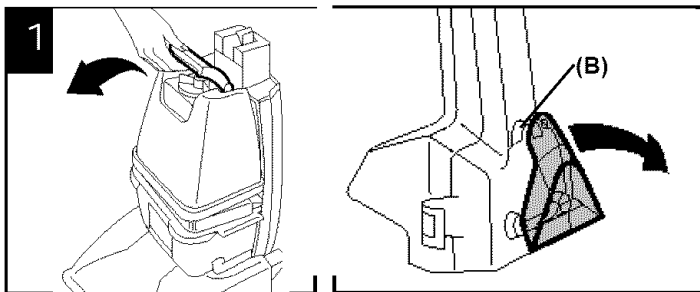

Remove clean solution tank (upper tank) (Fig. 1).

Remove nozzle stored on upper handle by gently pushing nozzle downward while pivoting it away from the handle at (B).

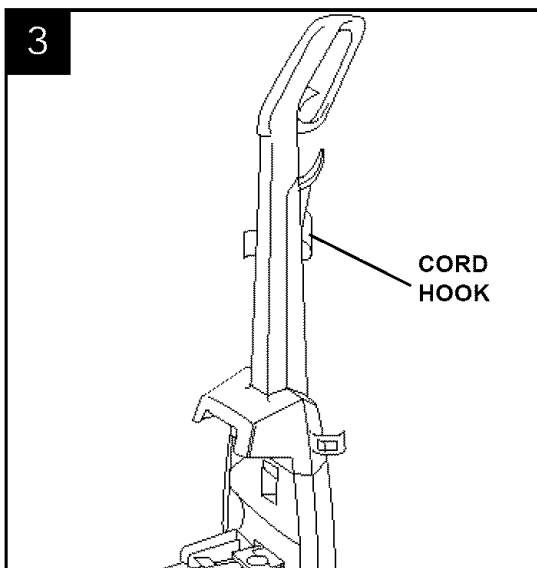

With cord hook to back of deep cleaner, push upper handle down onto lower handle. (Fig.3).

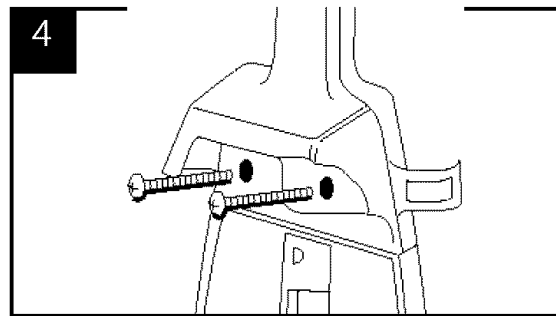

Push **bolts** into holes on **front of handle** (Fig. 4).
If bolts will not go through hole easily handle is not pushed completely down.

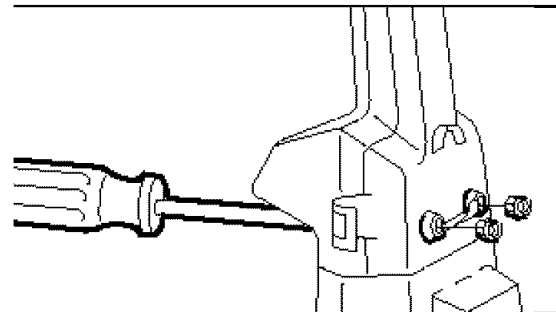

Place **nuts** in recessed areas on **back of handle**. Hold each nut in place while tightening each bolt securely with a Phillips screw driver (Fig. 5).

Only two nuts are needed on this model. The extra nut is not required but has been provided for your convenience.

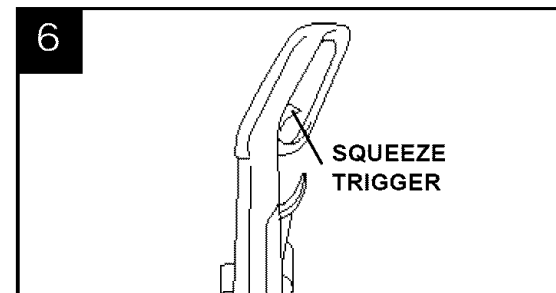

When handle sections are completely together, squeeze trigger on upper handle to snap trigger rod in place (Fig. 6).

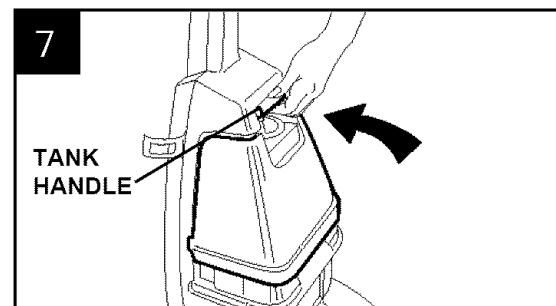

Replace clean solution tank (upper tank) by positioning bottom first. Press on tank handle to snap top of tank into place (Fig. 7).

Continued →

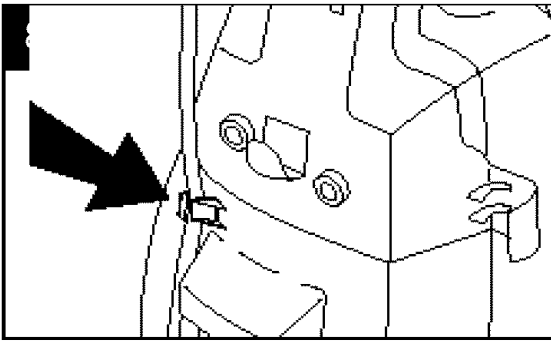

Press cord into cord clip on back of handle.
Pull cord tight (Fig. 8).

Attach lower hose holder (some models only)

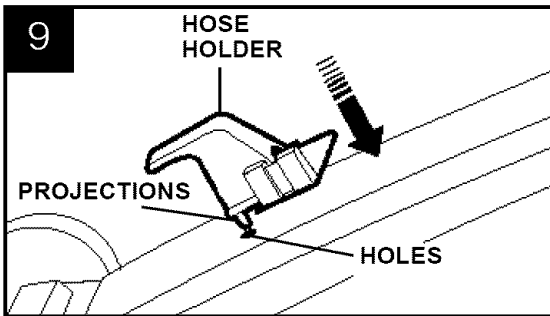

With front of deep cleaner resting on floor, place 2 projections on lower hose holder into 2 holes on back of cleaner (Fig 9).

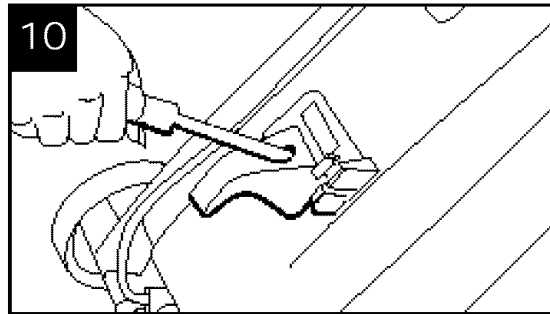

Push screw into hole and tighten securely with a Phillips screw driver (Fig 10).

Storing hose and nozzle on rack (some models only)

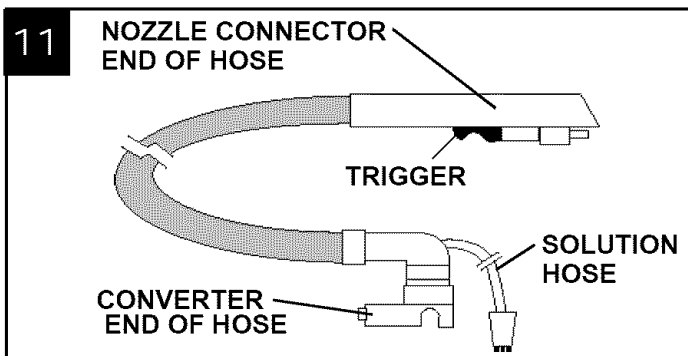

Stretch hose out and identify ends.

Note: You may find it helpful when storing the hose and nozzle to refer to the **information on the back of the deep cleaner and on the converter end of the hose** (Fig. 11).

4 Assembly

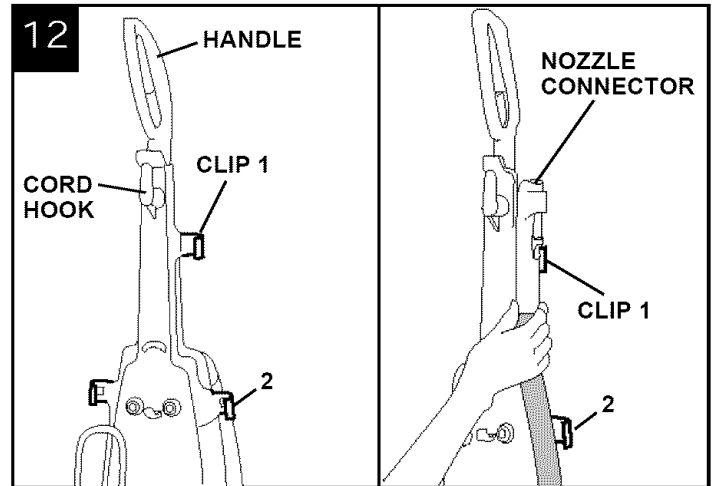

To store hose on rack, begin by placing **nozzle connector end of hose (straight end)** into clip 1 on rack (Fig. 12).

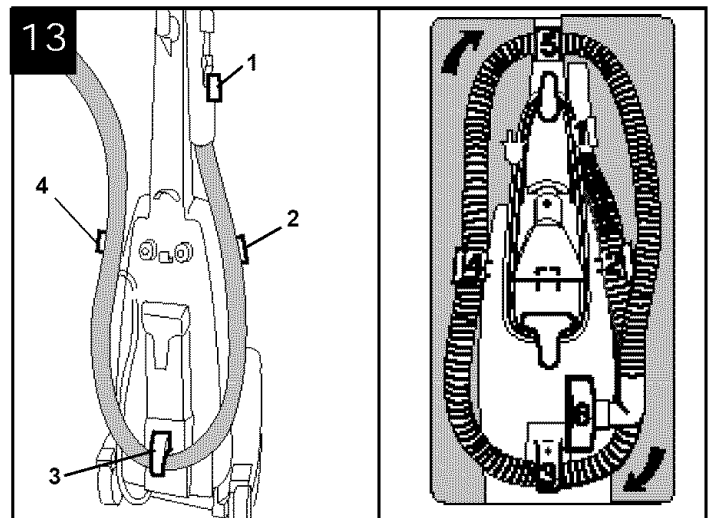

Secure hose to rack at numbered locations as shown. (Fig. 13)

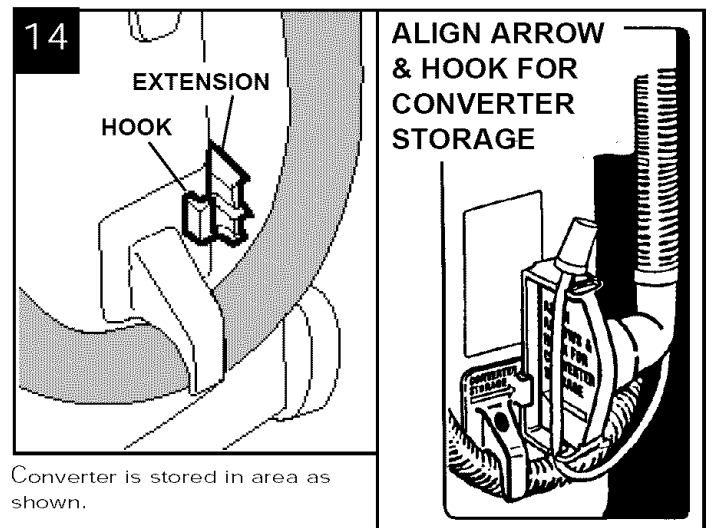

Converter is stored in area as shown.

While aligning arrows (Fig. 14), place extension into bottom of converter opening; then push converter firmly against deep cleaner until it snaps into place.

To remove, first pull top of converter off extension then pull off bottom.

Secure solution hose to converter as shown.

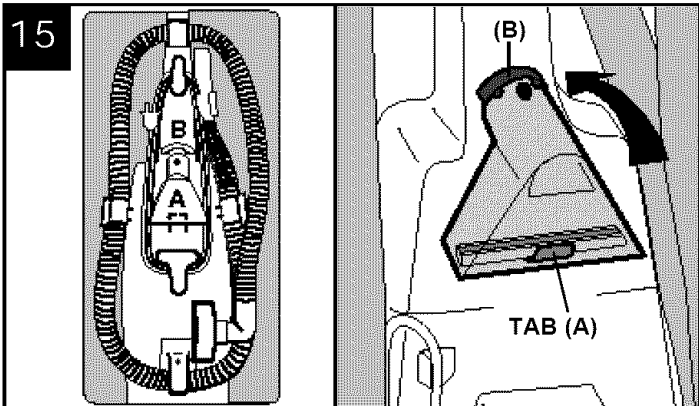

The nozzle is stored in the area between the cord hooks (Fig. 15).

Place **brushes** of nozzle on top of **Tab (A)** as shown. Gently push the nozzle downward while pivoting it into the nozzle holder **(B)**.

Deep cleaner description

The assembled deep cleaner will look like the drawing .

Models without hose rack

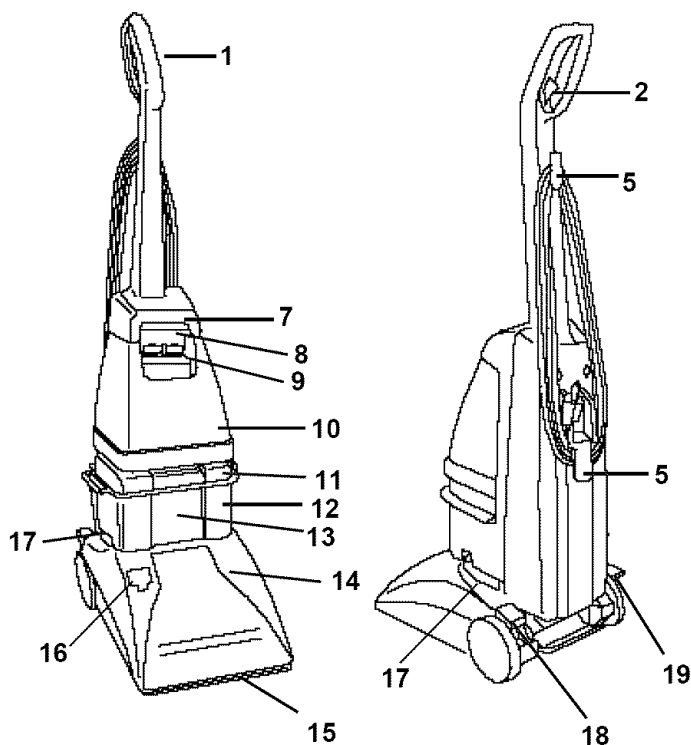

Models with hose rack

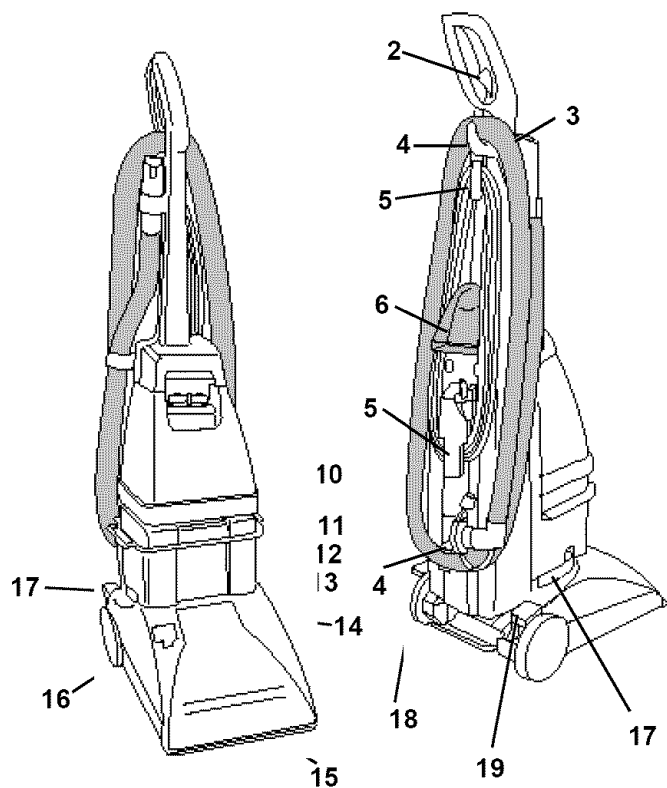

1. **Hand grip**
2. **Solution trigger:** press to release clean solution.
3. **Hose***
4. **Hose holders*:** wrap hose around holders for storage.
5. **Cord hooks:** wrap cord around hooks for storage.
The top hook can be rotated right or left for quick and easy cord release.
6. **Stair/upholstery nozzle***
7. **Carrying handle**
8. **Clean solution tank handle**
9. **Clean solution tank cap/ measuring cup**
10. **Clean solution tank:** holds cleaning solution.
11. **Recovery tank lid**
12. **Recovery tank:** holds dirty solution.
13. **Recovery tank "front panel"**
14. **Hood**
15. **Nozzle**
16. **Upholstery and stair cleaning connection*:** push door open to connect stair/upholstery nozzle "solution tube".
17. **Recovery tank latches:** one on each side of tank.
18. **ON/OFF pedal**
19. **Handle release pedal:** step on pedal to lower handle to operating position.

*Some models only

This deep cleaner is intended for household use.

General operation

Operate deep cleaner only at voltage specified on data plate on back of cleaner.

ON/OFF pedal

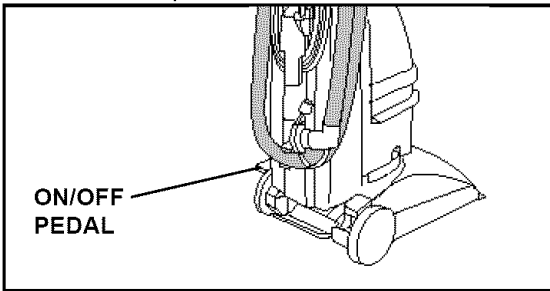

Plug deep cleaner into a properly grounded outlet.

Step on pedal to turn deep cleaner on. Step on pedal again to turn deep cleaner off.

Handle release pedal

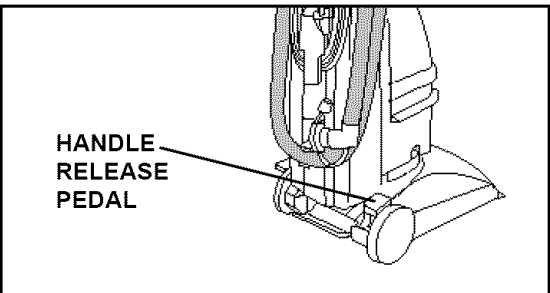

Step on pedal to lower handle to operating position. Handle does not lock into a single position but "floats" to allow convenient operation.

Automatic "shut-off"

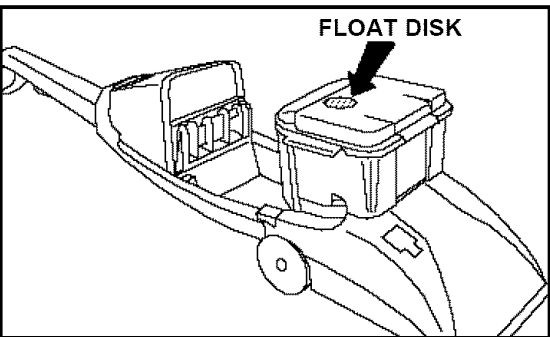

When the recovery tank (lower tank) is full, the automatic "shut-off" mechanism will shut off the deep cleaner suction.

At that time, the red float disk will rise to the top of the recovery tank lid (see illustration). The deep cleaner will no longer pick up dirty solution and the motor sound will become noticeably higher in pitch.

When this happens, turn deep cleaner off and empty recovery tank before continuing use.

Check clean solution tank also; it may need to be refilled.

To transport

Turn deep cleaner off before transporting

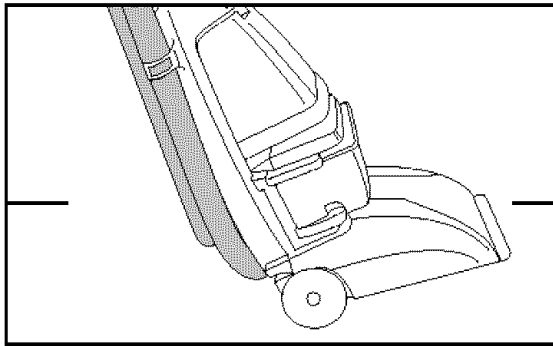

To move your deep cleaner from room to room, put handle in upright and locked position, tilt deep cleaner back on wheels, and push forward.

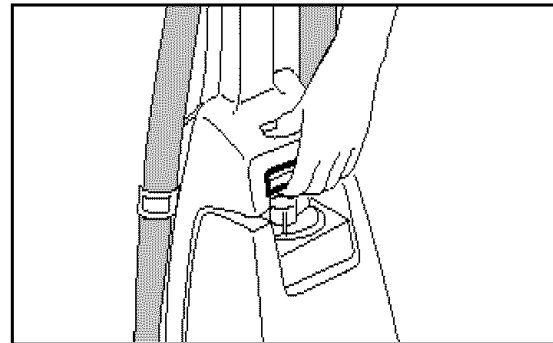

The deep cleaner may also be lifted by placing a hand under the upper clean solution tank handle as shown.

The tanks

Clean solution tank (upper tank)

The clean solution tank holds the cleaning solution that is to be dispersed onto the surface to be cleaned.

How to fill

Disconnect deep cleaner from electrical outlet.

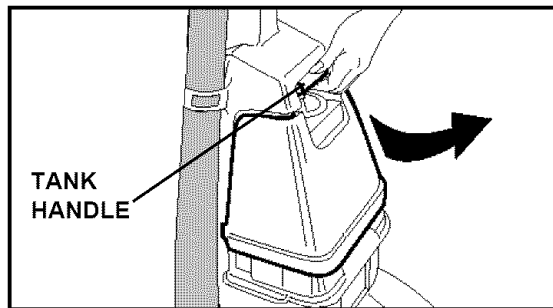

Place handle in the upright, locked position.

To remove tank, press down on handle and pull forward.

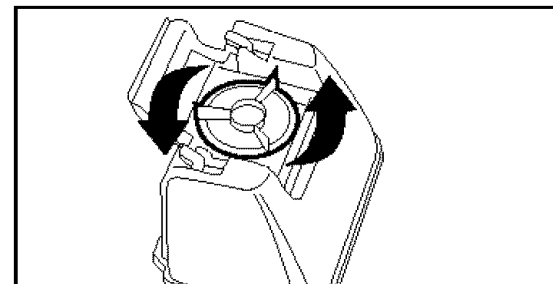

Carry tank to a sink.

Rotate tank cap counterclockwise and lift up to remove cap.

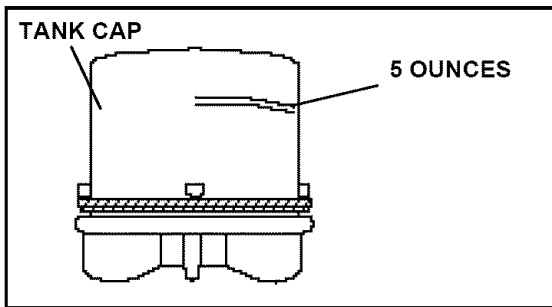

Turn cap upside down to serve as a measuring cup.

Using cap, measure detergent following the chart below.

For carpet, carpeted stairs and upholstery:

Fill cap to **fill line** (5 ounces) with HOOVER Carpet/Upholstery Detergent.

For bare floors:

Fill cap to **fill line** (5 ounces) with HOOVER Bare Floor Cleaner (available at additional cost if not included with your model.)

Do not use Bare Floor Cleaner on carpet or upholstery.

NOTE: Use only HOOVER detergents. They are specially formulated for use with your 'SteamVac' deep cleaner.

For heavy traffic areas:

Pre-treat with HOOVER PreCleaner Spray. If you do not have access to the PreCleaner Spray, double the amount of HOOVER Detergent (use 2 capfuls or 10 ounces per 1 gallon tank).

CAUTION: Detergents contain Anionic and Nonionic Surfactants. Avoid contact with eyes and skin. In case of contact with eyes, flush with cold water for 15 minutes. In case of contact with skin, wash with water. If irritation persists, call a physician. For Medical Information (U.S.) call 1-800-752-7869.

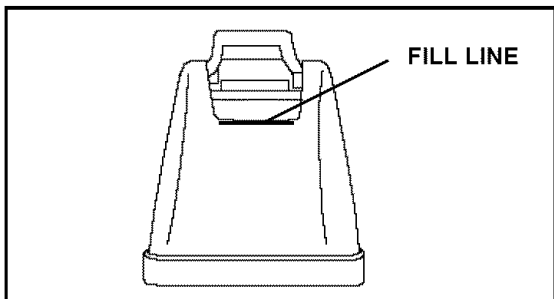

Pour detergent into tank.

Fill tank to fill line (1 gallon) with hot tap water.

To assure proper performance, use only 'Hoover' cleaning detergent.

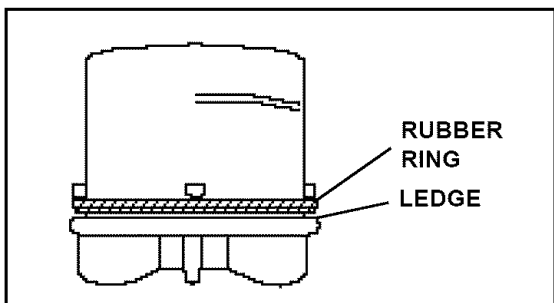

If rubber ring on cap has displaced, replace it with uneven side against cap ledge as shown.

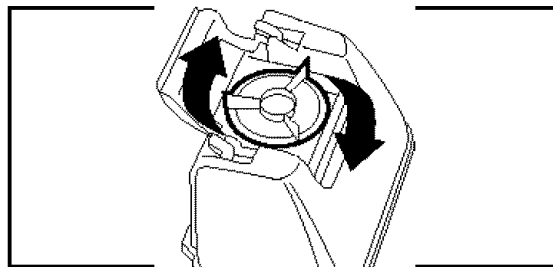

Replace cap. Rotate cap clockwise until it locks in place. Cap must be locked in place for proper performance and to prevent leaking.

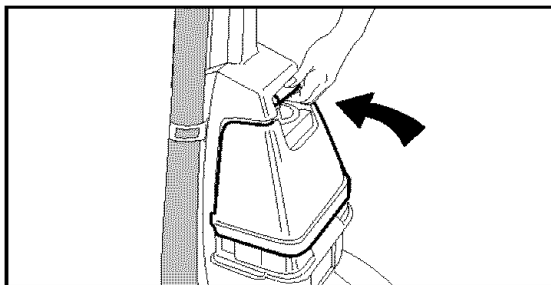

Position bottom of tank into unit and press on tank handle to snap tank into place.

Recovery tank (lower tank)

The recovery tank holds the dirty solution that is picked up from the carpet.

When the recovery tank is full, the automatic "shut-off" will engage (see page 6) and the tank must be emptied.

How to empty

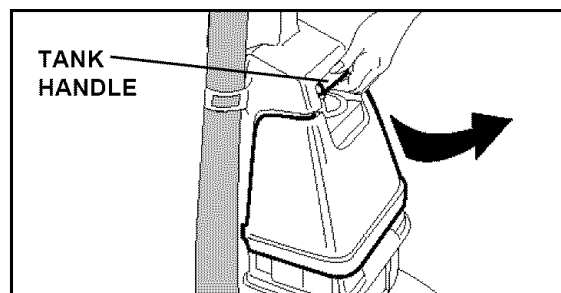

Turn deep cleaner off and disconnect from electrical outlet.

To prevent possible leaking, remove clean solution tank by pressing down on tank handle and pulling forward; set tank aside (do not set tank on furniture).

Continued →

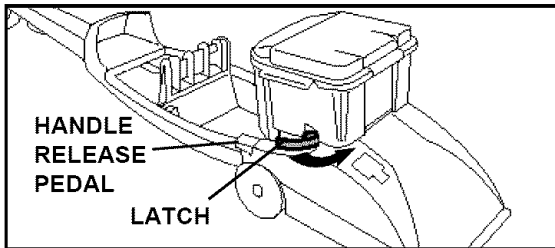

Step on handle release pedal and lower handle until it rests on the floor.

If cleaning stairs or upholstery, remove hose by reversing procedure as shown on page 11.

Rotate recovery tank latches outward (one on each side of tank).

Lift tank off of deep cleaner and carry it to a sink or drain.

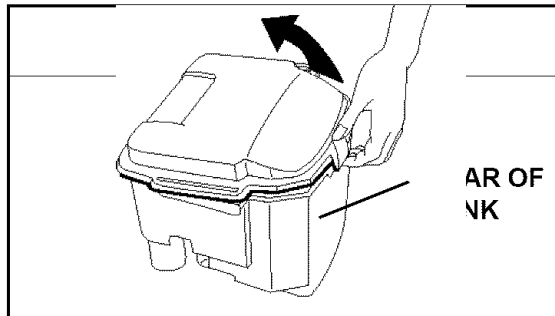

Unlatch back part of tank lid and remove lid.

Empty tank. Pour dirty water out from the rear of the tank.

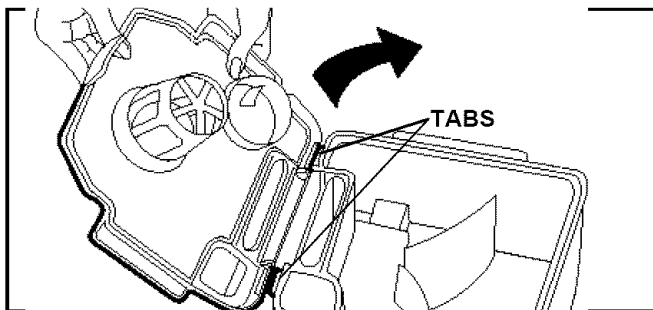

The lid replaces in a hinge-like manner. Position the front of lid under tabs on front of tank. Rotate lid down onto tank. **Make sure that the lid is secure on all sides before placing tank on cleaner.**

For full suction, it is important that the recovery tank lid is properly secured before cleaning.

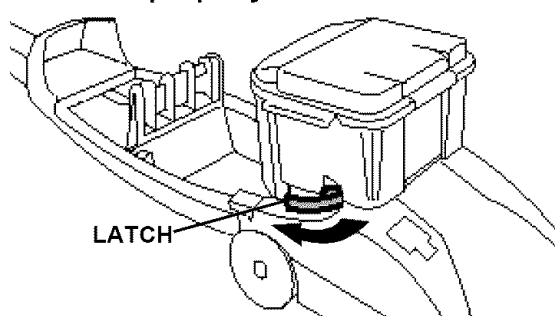

Replace tank and press down to ensure that it is properly seated in place.

Rotate latches (one on each side of tank) inward to lock tank in place.

To continue cleaning stairs or upholstery, replace hose as shown on page 11.

Raise handle to upright position and replace upper clean solution tank.

8 Emptying recovery tank - Before you begin

How to use

Before you begin cleaning

a. Vacuum thoroughly - For carpet, use a vacuum cleaner with an agitator for best results. Vacuum upholstery with a vacuum cleaner with cleaning tool attachments. Use a crevice tool to reach into tufts and folds. **Do not use the 'SteamVac' deep cleaner as a dry vacuum cleaner.**

b. For upholstery, check cleaning code - Use your HOOVER 'SteamVac' cleaning machine only if the upholstery fabric is marked with a "W" (for "wet" clean) or "S/W" (for "solvent/dry" or "wet" clean). **Do not clean fabric marked "S" ("solvent/dry" clean only).** If your upholstery does not have a code, seek professional assistance.

c. Test for colorfastness - Mix detergent and water according to the instructions under "Fill clean solution tank" on pages 6 and 7. Wet a white absorbant cloth with the solution. In a small, hidden area, gently rub the surface with the dampened cloth. Wait ten minutes and check for color removal or bleed with white paper towel or cloth. If surface has more than one color, check all colors.

d. When cleaning entire floor, move furniture out of area to be cleaned (may not be necessary if only high traffic areas are to be cleaned). For furniture too heavy to move, place aluminum foil or wax paper under legs. This will prevent wood finishes from staining carpet. Pin up furniture skirts and draperies.

e. Pretreat spots and heavy traffic areas with HOOVER® PreCleaner* - Test PreCleaner for colorfastness by first spraying it on a hidden area; wait ten minutes and blot with white paper towels or cloth.

If no color change is visible, spray PreCleaner onto spots and traffic areas. Wait at least ten minutes. Use your 'SteamVac' deep cleaner to pick up PreCleaner and spot. Repeat until spot is removed; carefully scrub with a household scrub brush if necessary. **Do not saturate carpet or upholstery with PreCleaner.**

No cleaning solution removes all stains from all carpets. Stain removal varies with the type of spill, time elapsed before removal, carpet material, and carpet type.

If you do not have access to the PreCleaner Spray, double the amount of HOOVER Detergent (use 2 capfuls or 10 oz. per 1 gallon) in the clean solution tank.

*Available at additional cost if not included with your model.

f. To prevent staining, use plastic or aluminum foil to protect wood or metal surfaces from possible water spray.

g. To avoid wetting and possible damage to wood floors underneath area rugs/carpet, either move area rugs/carpet to a non-wood bare floor surface or place waterproof material (e.g. plastic) underneath them before cleaning.

See pages 9-13 for instructions on various cleaning tasks.

After cleaning

a. Allow carpet or upholstery to dry. To help prevent matting and resoiling the carpet, keep children and pets away from surface until it is **completely dry**.

If it is necessary to walk on damp carpet, place towels or white cloths on the traffic areas.

If furniture must be replaced before the carpet is dry, use plastic or aluminum foil pads under legs of furniture so metal slides or wood finishes will not stain the carpet.

b. If desired, the carpet may be rinsed. **Rinsing is not necessary for cleaning**, but it may improve the surface's appearance after it is dry.

If rinsing is desired, be careful not to over-wet the carpet or upholstery. **Allow time for carpet or upholstery to dry completely between cleaning and rinsing.**

To rinse, follow the same procedure for cleaning only using hot tap water with no detergent in the upper clean solution tank.

c. Empty tanks, rinse with clear water and let air dry. Rinse the solution tank cap and recovery tank lid and let air dry.

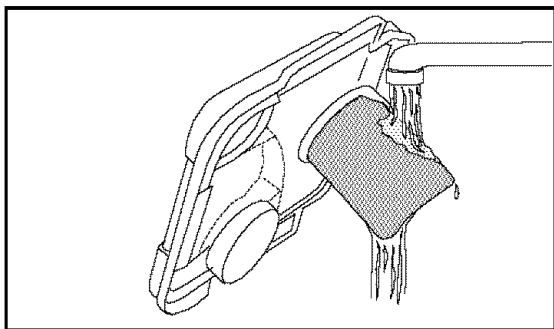

d. Remove debris from recovery tank filter and rinse with clean water.

Note: If the filter must be removed for cleaning, it is easier to replace if the filter is wet.

e. If desired, vacuum thoroughly after carpet has completely dried.

To clean nozzle

If lint or other debris becomes lodged in nozzle, **do not attempt to remove nozzle cover.**

Pour one to two cups of clear water on a non-carpeted floor.

Do not pour water onto a wood floor.

Pick up water with your 'SteamVac' deep cleaner. Repeat as necessary until debris is flushed out of nozzle.

Some models have a nozzle clean-out tool, as shown below, for removing debris or if a non-carpeted floor is not available.

Disconnect deep cleaner from electrical outlet.

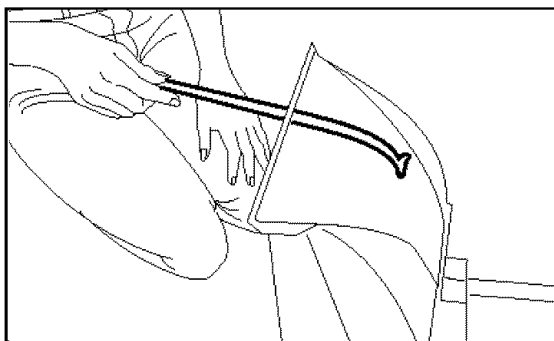

Slide tool into nozzle and remove debris.

To clean the outside of the machine wipe off dirt with a cloth dampened in warm water and a mild detergent. **Do not use solvent or petroleum based products to clean the machine.**

Cleaning carpet

Read "Before you begin cleaning" instructions on page 8.

Fill clean solution tank (upper tank) according to instructions on pages 6 and 7. Use 5 ounces of HOOVER Carpet/Upholstery Detergent.

Dry hands and plug cord into a **properly grounded outlet. Do not clean over floor electrical outlets.**

To avoid walking on damp carpet, start at the end of the room farthest from the door or path to sink where tanks will be emptied and filled.

Step on handle release pedal and lower handle to operating position; turn deep cleaner ON.

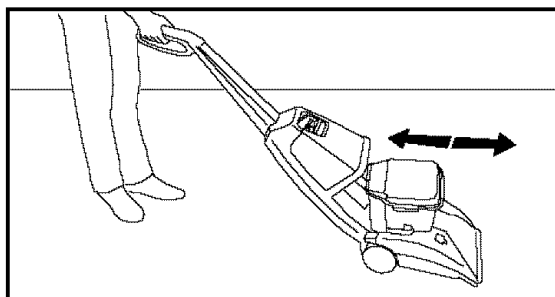

Squeeze trigger to release cleaning solution and **slowly** push deep cleaner forward (equals one wet stroke). Continue to squeeze trigger and **slowly** pull deep cleaner back toward you (second wet stroke).

Release trigger and **slowly** push deep cleaner forward over area just sprayed with solution (dry stroke). Then **slowly** pull deep cleaner back toward you without squeezing trigger (dry stroke).

Overlap strokes by one inch to help prevent streaking.

Keep nozzle flat on floor for both forward and reverse strokes.

For heavily soiled areas, repeat. **To avoid saturating carpet, do not use more than 4 wet strokes over one area. Always end with dry strokes.**

It is best to alternate wet and dry strokes as described above.

For best cleaning results and to aid in faster drying of carpet, end with more dry strokes. (Continue using dry strokes until little water is visible passing through the recovery tank lid.)

When finished cleaning, follow "After cleaning" instructions on page 9.

Picking up spills

Your HOOVER 'SteamVac' deep cleaner may also be used to pick up **small liquid spills (1 gallon or less, never to exceed 1/4 inch in depth)** on carpet, upholstery, or bare floors.

For best results, pick up spills immediately by placing the stair/upholstery nozzle just above the spill and suction up any residue on top of the carpet. If the spill remains, place either the stair/upholstery nozzle **or** floor nozzle in front of the spill, pull the nozzle very slowly over the spill initially with suction only. Repeat with spray and suction. **When picking up spills on bare floors, use only the floor nozzle with the bare floor attachment in place.**

If a spot is left, the stair/upholstery nozzle is generally more effective for removing it. Although no cleaning solution can completely remove all spots, they can be treated by following the instructions provided by the manufacturer of the carpet, upholstery, or bare floor surface being cleaned.

Do not use the 'SteamVac' deep cleaner to pick up flammable or combustible liquids or chemicals.

When finished, follow "After cleaning" instructions on page 9.

Cleaning bare floors

Some models come with the bare floor attachment. For others, the tool is available at additional cost from your Authorized Hoover Dealer (Depot) or a Hoover Factory Service Center.

How to attach bare floor attachment Disconnect deep cleaner from electrical outlet.

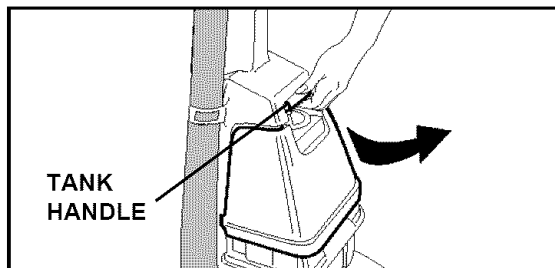

To prevent possible leaking, remove clean solution tank by pressing down on tank handle and pulling forward; set tank aside (do not set tank on furniture.)

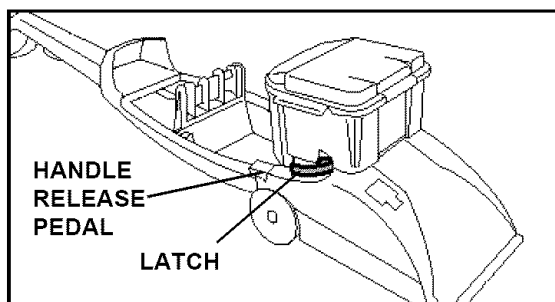

Step on handle release pedal and lower handle until it rests on the floor.

Rotate recovery tank latches (one on each side of tank) outward; lift tank off machine.

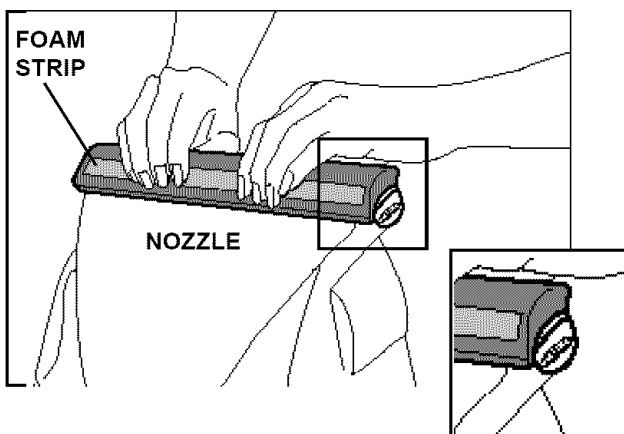

With handle in upright position, tilt deep cleaner back so that handle rests on floor.

Place attachment on front of nozzle with foam strip (under netting) in position as shown.

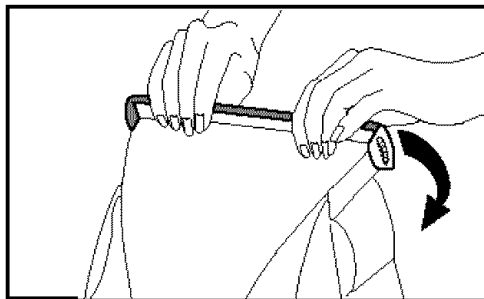

Push attachment against nozzle while rotating attachment downward until both ends "snap" into place.

(Note: Some force may be required to rotate and snap attachment into place.)

Return deep cleaner to upright position.

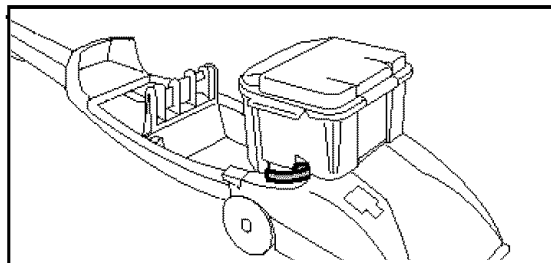

Lower handle and replace recovery tank. Press down to ensure that it is properly seated in place.

Rotate latches (one on each side of tank) inward to lock tank in place. Raise handle to upright position.

To clean floor

Read "Before you begin cleaning" instructions on page 8.

Do not use the 'SteamVac' deep cleaner on hardwood floors.

Fill clean solution tank according to instructions on pages 6 and 7. Use 5 ounces of HOOVER Bare Floor Cleaner.

Do not use any type of wax with your 'Steamvac' deep cleaner.

Dry hands and plug deep cleaner into a **properly grounded outlet.**

Step on handle release pedal and lower handle to operating position; turn deep cleaner ON.

To release solution, press trigger. Slowly move deep cleaner forward and backward over area to be cleaned.

To pick up dirty solution, release trigger and slowly move deep cleaner over area where solution has just been dispersed. Use both forward and reverse strokes.

When finished cleaning, follow "After cleaning" instructions on page 9.

Remove attachment from nozzle and rinse in clear water. **Do not remove plastic screen or foam from attachment.**

Using the stair/upholstery nozzle

Some models come with a hose and stair/upholstery nozzle.

How to attach hose

Disconnect deep cleaner from electrical outlet.

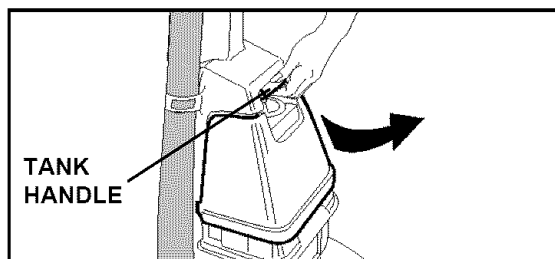

To prevent possible leaking, remove clean solution tank by pressing down on tank handle and pulling forward; set tank aside (do not set tank on furniture).

Remove hose from storage rack.

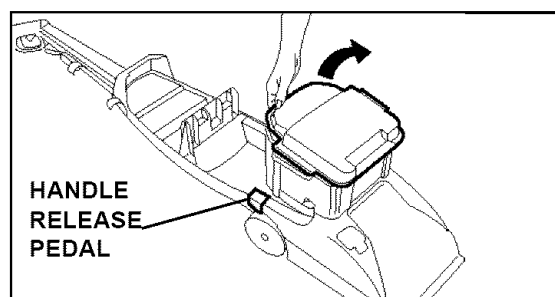

Step on handle release pedal and lower deep cleaner handle until it rests on the floor.

Unlatch back part of recovery tank lid and remove lid.

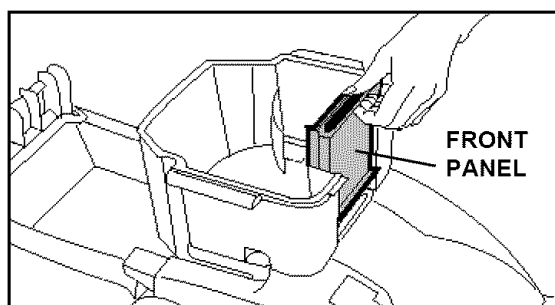

Remove recovery tank front panel by sliding it straight up.

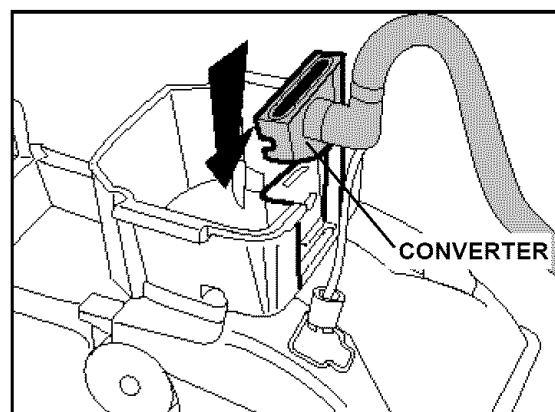

Replace panel with converter. Slide converter halfway down opening until it is firmly in place.

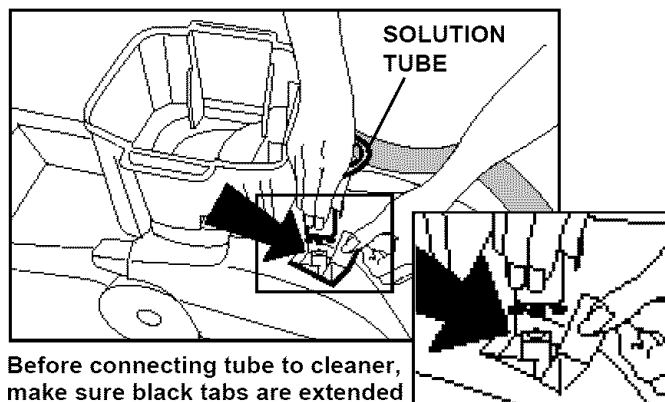

Before connecting tube to cleaner, make sure black tabs are extended by pulling tan collar toward tube.

Open door on hood labeled "Stair/Upholstery Cleaning Connection". Press round solution tube connector onto round projection inside door.

Press connector collar down firmly to ensure that it is fully connected.

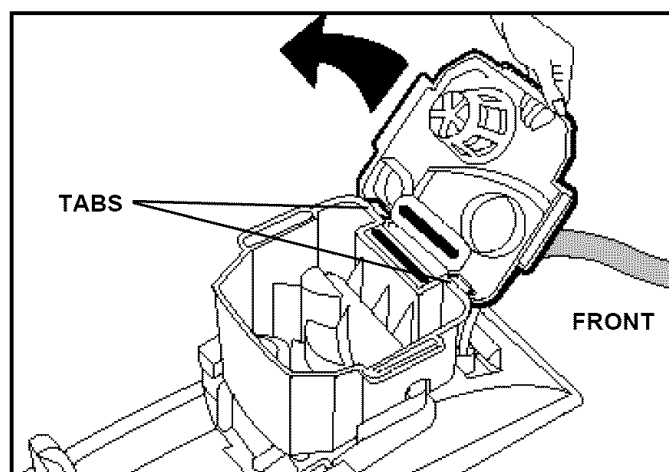

The tank lid replaces in a hinge-like manner. Position front of lid under tabs on front of tank. Rotate lid down onto tank. Make sure lid is secure on all sides before cleaning.

For full suction, it is important that the recovery tank lid is properly secured before cleaning.

Reverse procedure to remove hose and solution tube.

Raise deep cleaner handle to upright position.

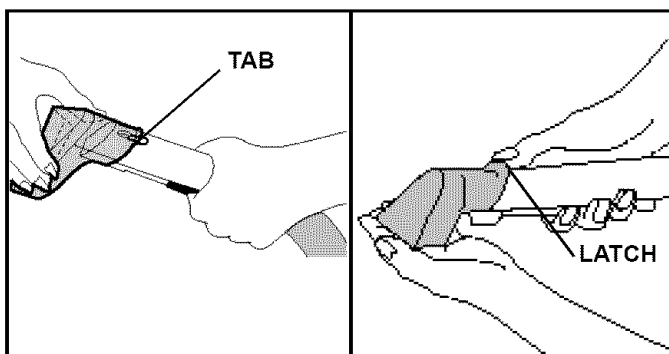

Attach nozzle to connector end of hose by sliding it onto connector until the tab locks it securely.

Using your thumb, **push forward and up** on the **latch** to remove nozzle.

Follow the instructions on pages 12 and 13 for the appropriate cleaning task.

After using stair/upholstery nozzle
Disconnect deep cleaner from electrical outlet.

Follow the instructions for "After cleaning" on page 9.

Drain suction hose by turning deep cleaner on and holding nozzle up for several minutes. **Do not press trigger. Disconnect cleaner from electrical outlet.**

Disconnect hose and solution tube from deep cleaner.

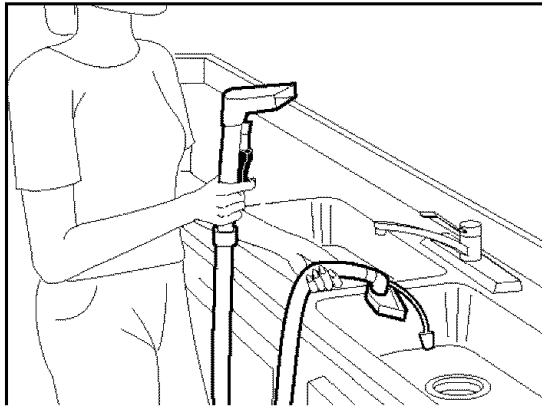

Drain solution tube by placing round end in sink, and raising nozzle above your head. Press the trigger.

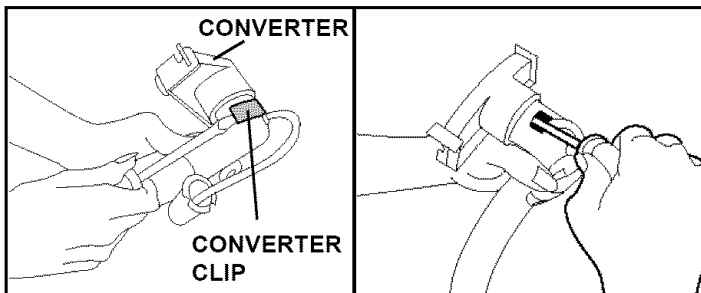

Occasionally, debris may become lodged inside of the hose at the converter end.

To clean-out the hose, lift bottom of converter clip with a screw driver and remove clip. Remove debris as shown.

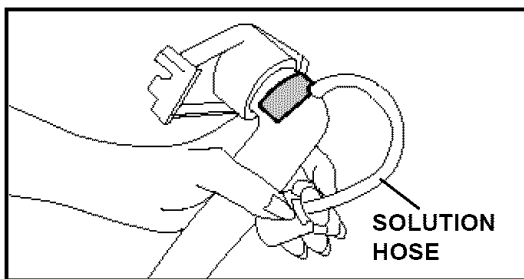

Snap clip back into position making sure solution hose is not pinched and moves freely.

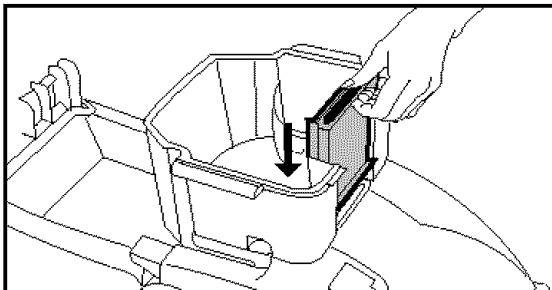

Replace recovery tank front panel. **Slide panel down until it snaps firmly in place.**

Cleaning carpeted stairs

Read "Before you begin cleaning" instructions on page 8.

Attach hose and solution tube as instructed on page 11.

Fill clean solution tank according to instructions on pages 6 and 7. Use 5 ounces of HOOVER Carpet/Upolstery Detergent.

Hose length may require that machine be placed at the top of the stairs to clean upper half of stairway and at bottom of stairs to clean lower half.

To prevent machine from falling, use extra caution when cleaning on stairs. Do not place deep cleaner on stairs.

Do not point stair/upholstery nozzle at people or pets.

Dry hands and plug deep cleaner into a **properly grounded outlet.**

Turn deep cleaner ON.

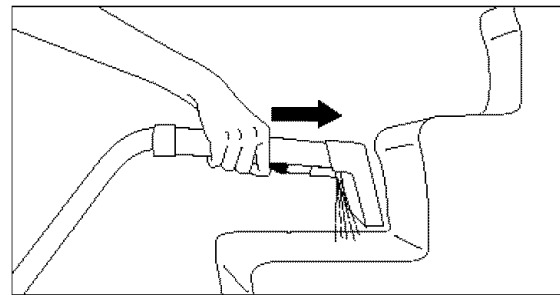

Pre-spray the carpeted stair by holding the nozzle about one inch above the carpet and push the wand forward while pressing the solution trigger (equals one wet stroke).

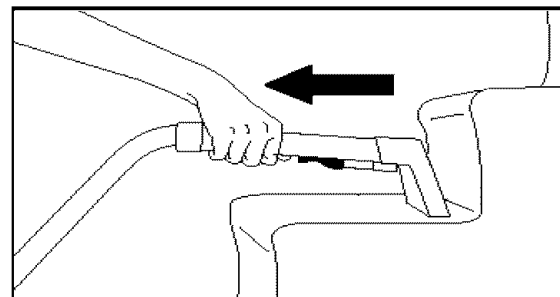

Position nozzle against the riser and slightly press nozzle into carpet pile. Press the solution trigger and pull the nozzle **slowly** over the carpet (second wet stroke).

Release the trigger, lift nozzle, and position it against riser. Pull nozzle **slowly** over carpet without pressing trigger (dry stroke).

It is best to alternate wet and dry strokes as described above. End with more dry strokes to aid in faster drying of carpet.

Overlap strokes by one-half inch to help prevent streaking.

To avoid saturating carpet, do not use more than 4 wet strokes over any one area. Always end with dry strokes.

If additional cleaning is necessary, wait until the carpet is completely dry before using the nozzle again.

When finished cleaning, follow "After cleaning" instructions on page 9 and "After using stair/upholstery nozzle" instructions on page 12.

Cleaning upholstery and automobile interiors

Read "Before you begin cleaning" instructions on page 8. Be sure to check the cleaning code on your upholstery. **Use your HOOVER 'SteamVac' deep cleaner only on upholstery marked "W" or "W/S".**

Attach hose and solution tube as instructed on page 11. Fill clean solution tank according to instructions on pages 6 and 7. Use **5 ounces** of HOOVER Carpet/Upholstery Detergent.

Dry hands and plug deep cleaner into a **properly grounded outlet.**

Turn deep cleaner ON.

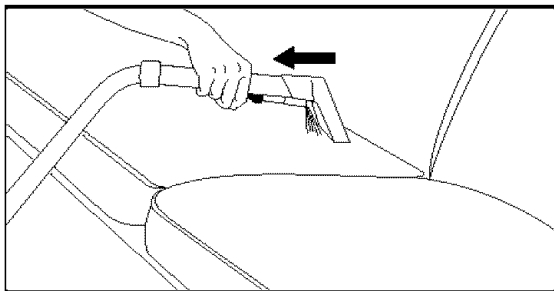

Gently press the nozzle onto the fabric. Press the solution trigger and slowly pull the nozzle over the fabric.

Overlap strokes by one-half inch to help prevent streaking.

Make additional strokes without pressing the trigger to remove more moisture.

To clean in corners or creases, lift the nozzle one-half inch from the fabric and press the solution trigger. Vacuum up the solution with the nozzle without pressing the trigger.

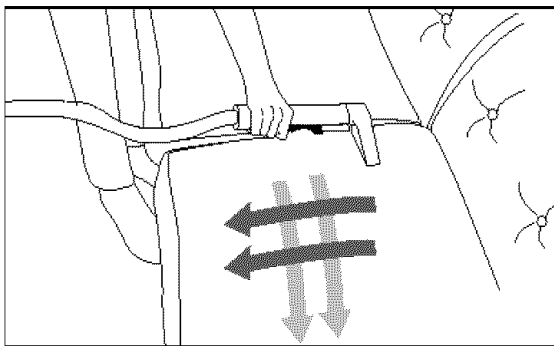

For heavily soiled areas, it may be necessary to repeat the cleaning process. Make crisscrossing strokes to the original pattern; overlap each pass.

Make no more than 2 passes with the solution over any one area to prevent overwetting and damage to fabric.

If additional cleaning is necessary, wait until the upholstery is completely dry before using the nozzle again.

When finished cleaning, follow "After cleaning" instructions on page 9 and "After using stair/upholstery nozzle" instructions on page 12.

Storage

Before storing:

- Empty solution tank and rinse thoroughly with clean water.
- Replace **empty** solution tank and turn deep cleaner ON. Squeeze trigger and push deep cleaner forward and back several times to expel any solution remaining in the deep cleaner's system. (Do not use deep cleaner on wood floors.)
- Empty recovery tank and rinse thoroughly with clean water.

Allow underside of deep cleaner to air dry thoroughly before storing deep cleaner on a carpeted or wood surface.

Do not store deep cleaner with a full solution tank in place.

Lubrication

The motor is equipped with bearings which contain sufficient lubrication for the life of the motor. The addition of lubricant could cause damage. **Do not add lubricant to motor bearings.**

Continued →

If you have a problem

If a minor problem occurs, it usually can be solved quite easily when the cause is found by using the check list below.

Problem: Machine won't run

Possible cause

Possible solution

- **Not firmly plugged in**
 - Plug unit in firmly
- **No voltage in wall plug**
 - Check fuse or breaker
- **Blown fuse/tripped breaker**
 - Replace fuse/reset breaker

Problem: Low suction

Possible cause

Possible solution

- **Recovery tank lid not on correctly**
 - Make sure lid is on securely (page 8)
- **Recovery tank full/automatic shut off engaged**
 - Remove and empty recovery tank
- **Obstruction in hose on stair/upholstery nozzle**
 - Remove hose; clear obstruction
- **Recovery tank front panel not replaced after stair or upholstery cleaning**
 - Replace recovery tank front panel (page 12)

Problem: Clean solution won't dispense

Possible cause

Possible solution

- **Solution tank not firmly in place**
 - Make sure tank is securely locked in position
- **Solution tank empty**
 - Refill tank according to instructions for surface being cleaned (pages 6 & 7)
- **Recovery tank lid not on correctly**
 - Make sure lid is firmly in place (page 8)
- **Stair/upholstery solution tube not securely fastened**
 - Make sure tube is securely fastened at connection of hood

Problem: Solution tube on stair/upholstery nozzle won't connect

Possible cause

Possible solution

- **Connector collar pushed forward**
 - Extend black tabs on connector by pulling collar towards tube

Service

To obtain approved HOOVER service and genuine HOOVER parts, locate the nearest **Hoover Factory Service Center or Authorized Hoover Warranty Service Dealer (Depot)** by:

- checking the Yellow Pages under "Vacuum Cleaners- Household" OR -
- checking the list of Factory Service Centers provided with this cleaner OR -
- calling **1-800-944-9200** for an automated referral of authorized service outlet locations (U.S. only) OR -
- checking the Service section of The Hoover Company on-line at www.hoover.com

Do not send your cleaner to The Hoover Company in North Canton for service, this will only result in delay.

If further assistance is needed, contact The Hoover Company Consumer Response Center, North Canton, Ohio 44720 Phone: 1-330-499-9499.

In Canada, contact Hoover Canada, Burlington, Ontario L7R 4A8, Phone: 1-800-263-6376.

Always identify your cleaner by the **complete** model number when requesting information or ordering parts. (The model number appears on the back of the cleaner handle.)