

# ELECTRIC GLASS SURFACE BUILT-IN COOKTOPS

36" MODEL: KECT-3645

## INSTALLATION INSTRUCTIONS

### INSTALLER: FINAL CHECKLIST

#### IMPORTANT:

**LEAVE THESE INSTRUCTIONS FOR USE BY  
THE LOCAL ELECTRICAL INSPECTOR**

#### PLACEMENT OF COOKTOP

- 1. Specified clearances maintained to adjacent surfaces.
- 2. Unit secure to countertop.

#### ELECTRICAL

- 1. Unit properly grounded.
- 2. Check that unit is connected to proper volt, amp and breaker ratings per Electrical Specifications given in this booklet.
- 3. All connections made in accordance with local and/or National Electrical Code.

#### OPERATIONAL

- 1. Knobs installed on switches.
- 2. Individual element indicator light comes on when the element is turned on.

Unless instructed to leave for owner, remove all tags, labels, and internal packing material.

### THANK YOU INSTALLER:

1. Complete Installation Checklist.
2. Leave all literature for customer.
3. Notify dealer that installation is completed.

---

**FOR DETAILED INSTRUCTIONS, FOLLOW METHODS DESCRIBED IN THIS FOLDER.**

**IMPORTANT: Read completely before installing to save time, work, assure proper performance, and owner's warranty protection.**

**ELECTRICAL SPECIFICATIONS**  
KECT-3645

Voltage and Frequency	240 volts 60 Hertz
Maximum Watts	8100 watts
Operating Load	33.75 amperes
Maximum Protective Device Size	40 amperes
Minimum Circuit Size	40 amperes

**WARNING: ELECTRICAL AND GROUNDING CONNECTIONS MUST COMPLY WITH APPLICABLE PORTIONS OF THE NATIONAL ELECTRICAL CODE AND/OR OTHER LOCAL ELECTRICAL CODES.**

The bare copper wire in factory installed conduit is the unit ground wire, not a neutral conductor.

## INSTALLATION INSTRUCTIONS

All work should be done by a qualified electrician who is familiar with the National Electrical Code and/or Local Codes.

**WARNING: DISCONNECT ELECTRICAL POWER SUPPLY AND PLACE A TAG AT THE DISCONNECT SWITCH INDICATING THAT YOU ARE WORKING ON THE CIRCUIT.**

Before installing unit be sure that the electrical supply meets the electrical specifications given in this booklet.

### SECTION A — ELECTRICAL SUPPLY

A junction box, not provided, below the countertop is necessary for the connection of the 4-foot length of 1/2" flexible conduit supplied with the cooktop. Figure A shows the location of the conduit.

All units are 3 inches deep. An additional 1-1/2 inches at the rear of the unit is needed for the electrical connections. See side view of Figure A.

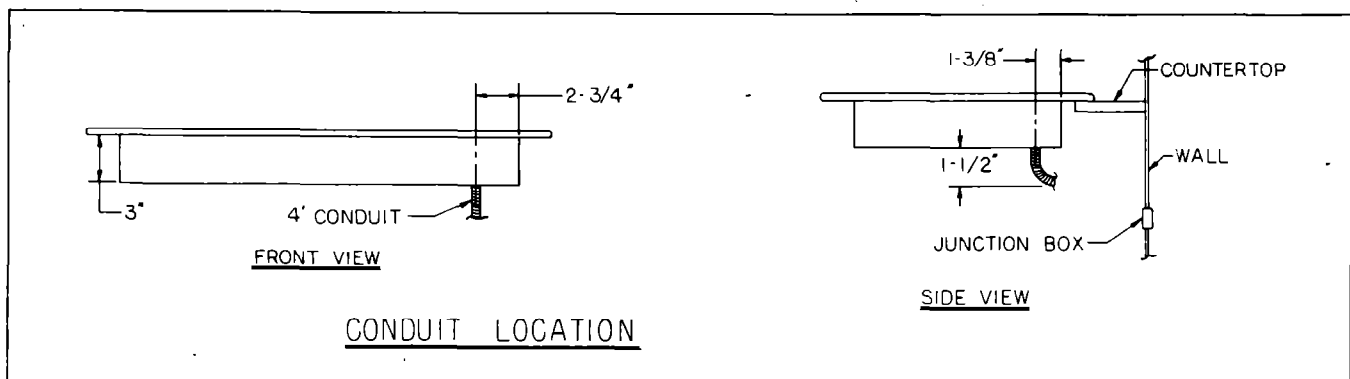

Fig. A

### SECTION B — UNPACK UNIT

Remove all packing material from unit. Do not dispose of inner packaging - it is needed during installation.

**FOR REPLACEMENT COOKTOP INSTALLATION INSTRUCTIONS GO TO SECTION D**

**SECTION C — CABINET CONSTRUCTION — NEW INSTALLATION**

THE FOLLOWING INSTRUCTIONS ARE FOR NEW INSTALLATIONS ONLY.

All cooktops are designed for installation in a base cabinet with a countertop depth of 24". For information on top cabinet location see notes below.

Countertop cutout dimensions are given in Figure 1. When the illustration is followed the required clearances from the front edge of countertop and the nearest vertical and rear walls will be obtained.

**NOTE:** To eliminate the risk of burns or fire by reaching over the heated surface elements, cabinet storage space located above the cooktop should be avoided. If cabinet storage is to be provided, the risk can be reduced by installing a range hood that projects horizontally a minimum of 5 inches beyond the bottom of the cabinets.

**NOTE:** "A" = 30" min. clearance between the top of the cooking surface and the bottom of an unprotected wood or metal cabinet.  
 "A" = 24" min. when bottom of wood or metal cabinet is protected by not less than 1/4" flame retardant millboard covered with not less than No. 28 MSG sheet steel, 0.024" aluminum, 0.015" stainless steel or 0.020" copper.

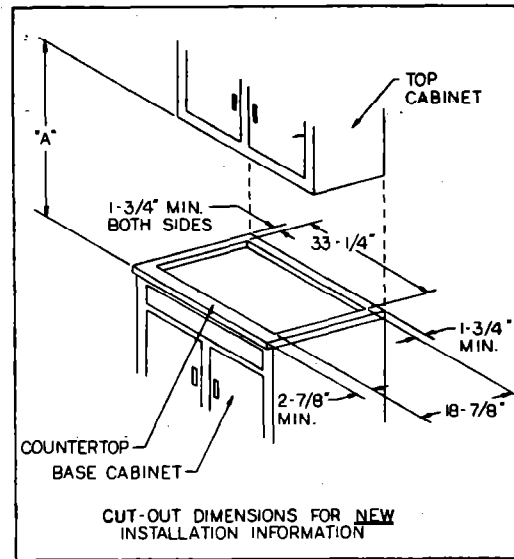

**Fig. 1**

CONTINUE INSTALLATION INSTRUCTIONS WITH SECTION E — INSTALLING UNIT

**SECTION D — CABINET CONSTRUCTION — REPLACEMENT INSTALLATIONS**

THE FOLLOWING INSTRUCTIONS ARE FOR REPLACEMENT INSTALLATIONS ONLY.

All cooktops are designed for installation in a base cabinet with a countertop depth of 24". For information on top cabinet location see notes below.

The minimum and maximum countertop cutout dimensions are given in Figure 2 and chart below. The side wall clearances in the diagram are recommended clearances.

**IMPORTANT NOTE:** In order to comply with UL safety standards the front edge of the cooktop must be a minimum of 1-1/2" from the front edge of the countertop. See Figure 3.

**NOTE:** To eliminate the risk of burns or fire by reaching over the heated surface elements, cabinet storage space located above the cooktop should be avoided. If cabinet storage is to be provided, the risk can be reduced by installing a range hood that projects horizontally a minimum of 5 inches beyond the bottom of the cabinets.

**NOTE:** "A" = 30" min. clearance between the top of the cooking surface and the bottom of an unprotected wood or metal cabinet.  
 "A" = 24" min. when bottom of wood or metal cabinet is protected by not less than 1/4" flame retardant millboard covered with not less than No. 28 MSG sheet steel, 0.024" aluminum, 0.015" stainless steel or 0.020" copper.

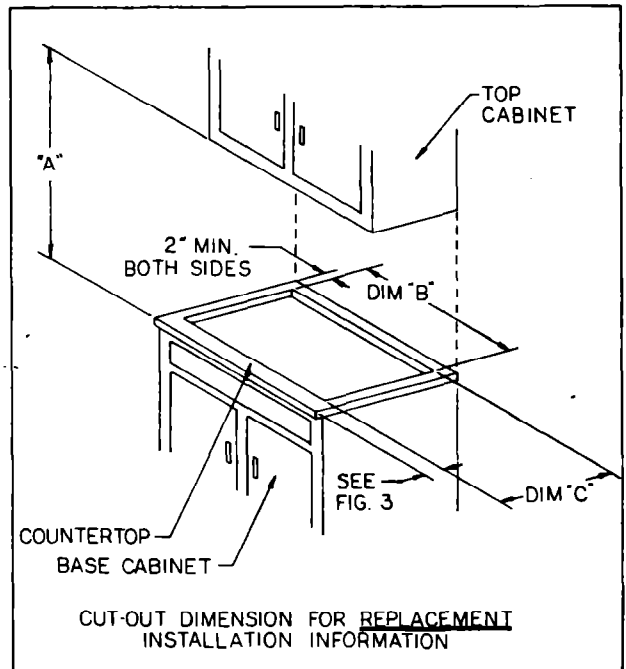

**Fig. 2**

	Minimum	Maximum
Dim. B	33"	34-7/8"
Dim. C	18-3/4"	20-5/8"

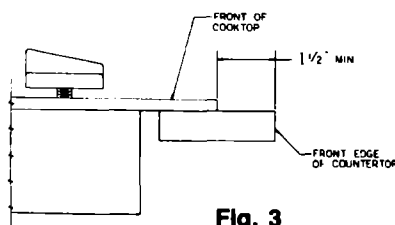

**Fig. 3**

## SECTION E — INSTALLING UNIT

**STEP 1:** Remove mounting hardware and foam seal strip from packaging.

**STEP 2:** Place cooktop in countertop cutout. Center and align cooktop making sure that required clearances are maintained. Draw an outline of the back edge of the cooktop onto the countertop using a pencil or any erasable/removable marker. Remove cooktop from opening and place upside down on inner packaging.

**STEP 3:** If your cutout is less than 19-1/2" front to back proceed with Step 4. If your cutout is greater than 19-1/2" front to back the cooktop must be centered to hold the cooktop/countertop alignment. To center screw the four 1-1/4" centering screws into the two front and two back mounting holes by hand. See Figure 4. Turning the screws adjusts their length to fill the space between the front or back of the cooktop and the countertop cutout. To adjust the back centering screws measure the distance - Dim. "D" - between the back of the cutout and the cooktop outline. See Figure 4. Adjust the length of the back centering screws until the distance between the screw head and the edge of the cooktop equals Dim. "D". Do not adjust front centering screws at this time.

**STEP 4:** While removing the backing paper place the foam seal strip 1/8" from the inside edge of the glass in one continuous piece (strip will overlap four support brackets). See Figure 5. Cut off any excess material.

**STEP 5:** Using the 5/16" screws, loosely screw the plain end of clamping brackets into each hole on the bottom of the cooktop. See Figure 6. Rotate the brackets inward. Return cooktop to countertop cutout using outline as a guide for lowering cooktop into cutout. If cooktop is not properly aligned, lift complete unit and lower again. This is to prevent any damage to the foam seal strip.

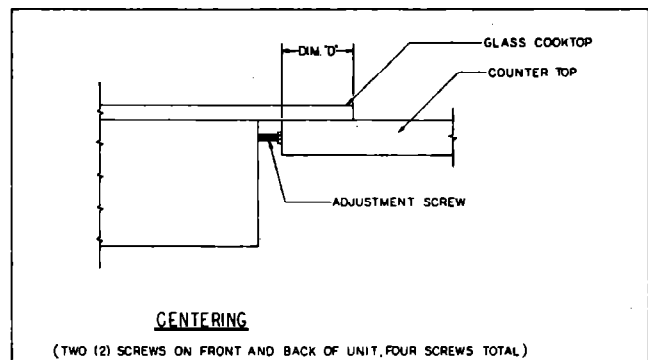
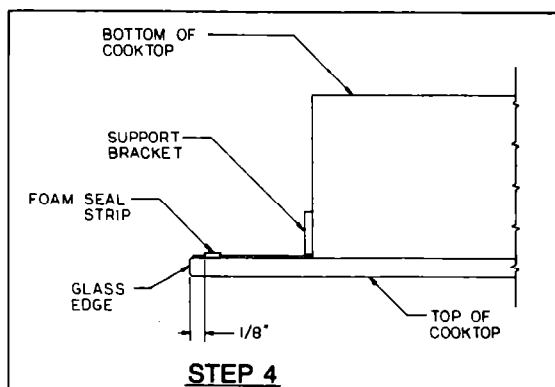

**Fig. 4**

If you centered your cooktop (Step 3) adjust the front screws until the cooktop is held firmly in place before proceeding.

Rotate clamping bracket out and tighten 5/16" screws. Thread 2-1/2" clamping screw through threaded inset in bracket. Tighten the clamping screws with a screwdriver until the screws are tight against the countertop.

Remove outline marking.



**Fig. 5**

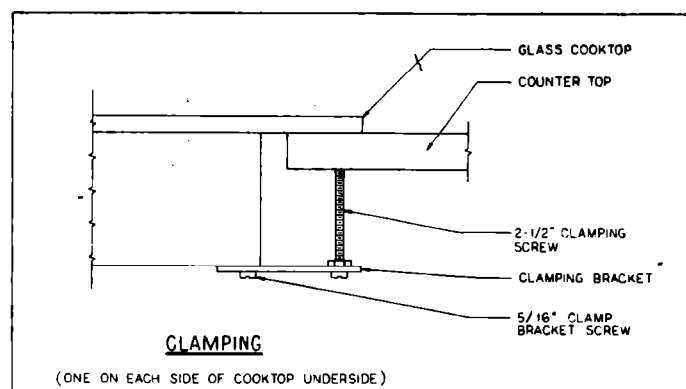

**Fig. 6**

Using entire length of conduit, properly connect power supply leads from the unit to the junction box. **DO NOT CUT CONDUIT.**

**WARNING:** IMPROPER CONNECTION OF WIRES MAY DAMAGE COOKTOP. IF JOINING TO ALUMINUM HOUSE WIRING PURCHASE CONNECTIONS FOR JOINING COPPER TO ALUMINUM AND FOLLOW THE MANUFACTURER'S DIRECTIONS CLOSELY.

Refer to Installation Checklist on front cover of this booklet.

Specifications Subject to Change Without Notice.

**HOBART**

TROY, OHIO 45374

4177290