

CAUTION: DISCONNECT ELECTRIC CURRENT BEFORE SERVICING

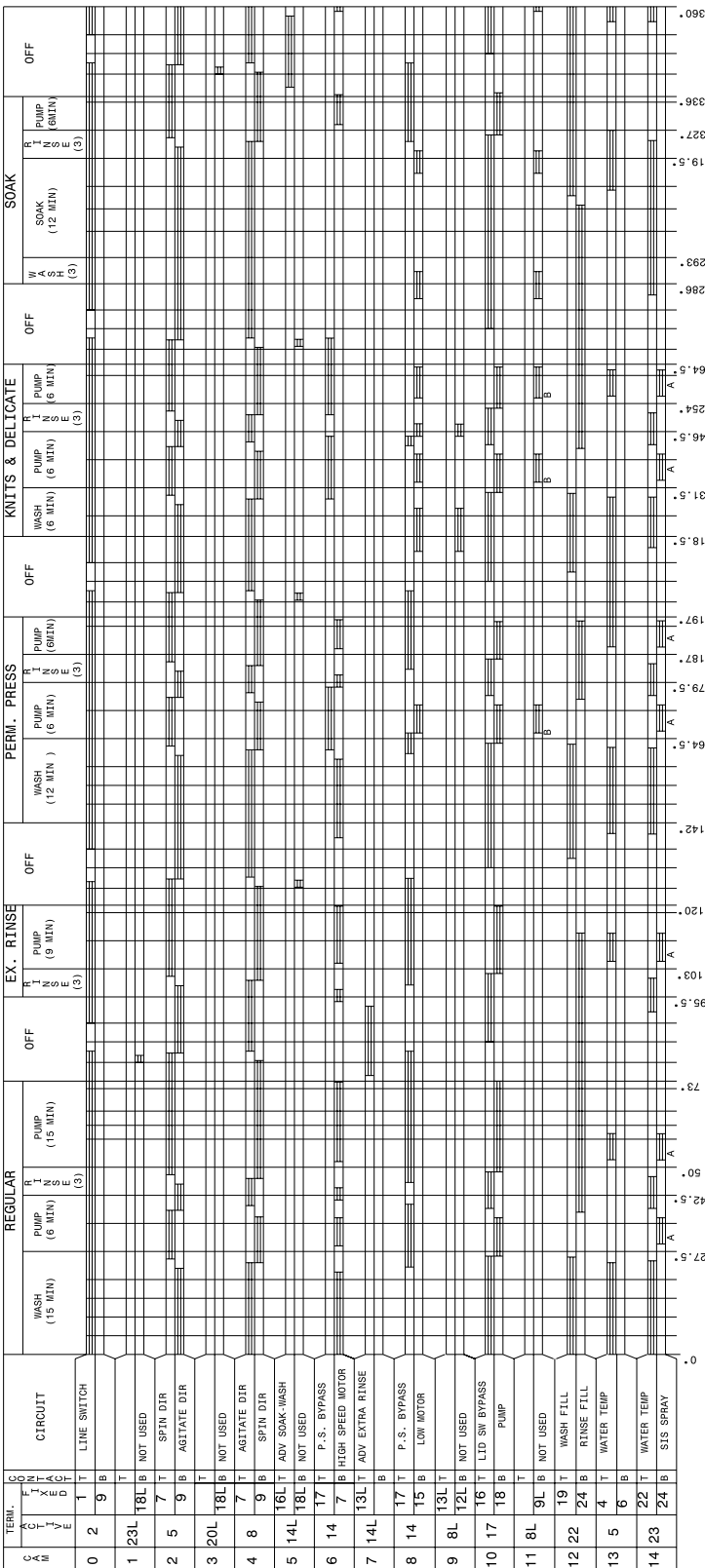

CAUTION: DISCONNECT ELECTRIC CURRENT BEFORE SERVICING

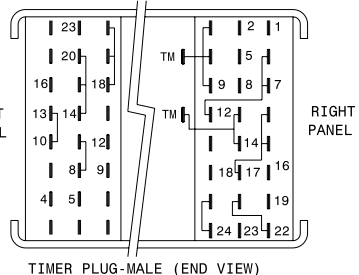
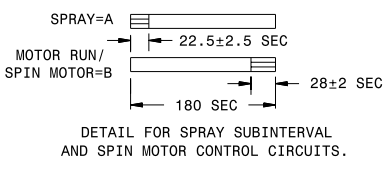
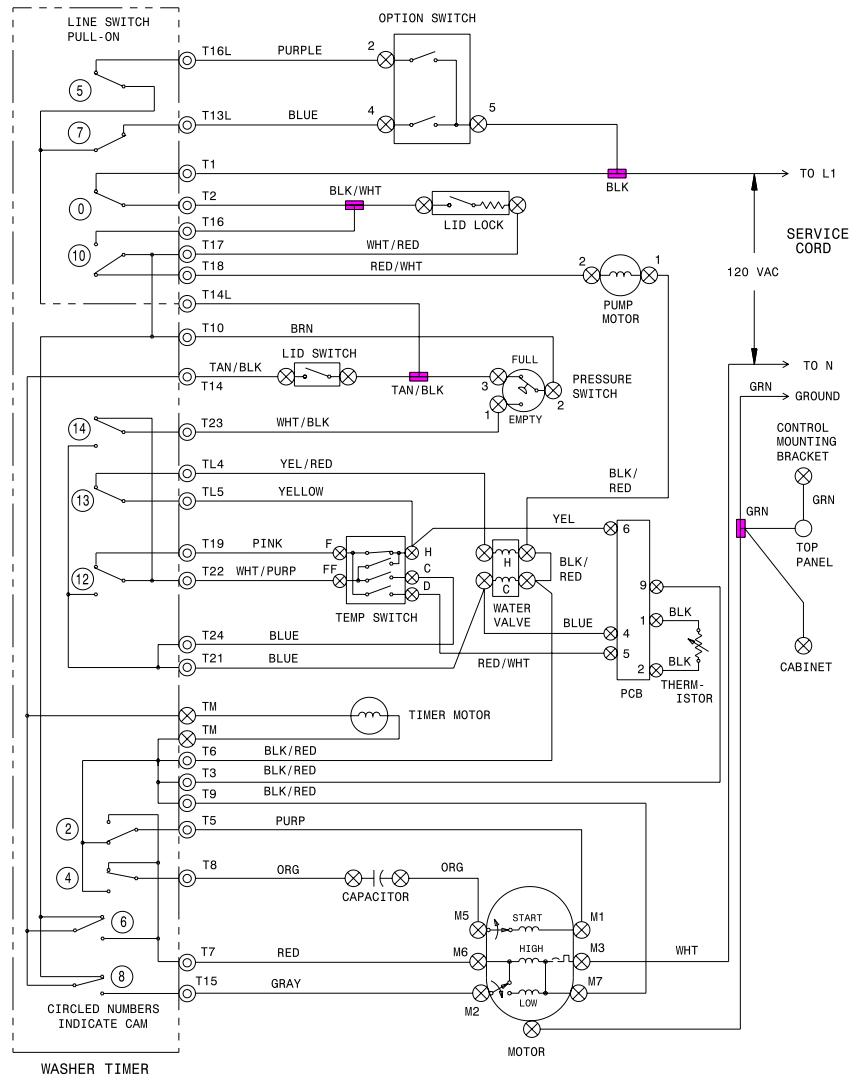

**WIRING CODES**

- ⊙ PLUG IN TIMER TERMINAL
- ⊗ QUICK DISCONNECT TERMINAL
- SCREW TERMINAL
- CONNECTION
- + NO CONNECTION
- ⚡ MOTOR SWITCH
- SPLICE
- ⚡ MOTOR PROTECTOR
- ⏏ CHASSIS (CABINET) GROUND

**\* OPTION SWITCH**

POS	OPTION	1-9	1-3	5-4	5-2
1	POWER SCRUB/ EXTRA RINSE			X	X
2	EXTRA RINSE	X		X	
3	POWER SCRUB		X		X
4	OFF	X	X		

**TEMPERATURE SWITCH CIRCUIT**

WASH/RINSE	F-H	FF-H	FF-C	F-D
H/C	X			
* W/C	X		X	
* C/C			X	
* W/W		X	X	
R C/C			X	X
R W/C	X			X
R W/W		X		X

H=HOT C=COLD W=WARM  
R=REGULATED  
\* NOT ON ALL MODELS.

X=CONTACTS CLOSED  
\* TERMINALS 1, 3, & 9 NOT USED ON ALL MODELS.

**WIRING DIAGRAM**  
**134381300**