

## Washer Tech Data Sheet

This information is intended for Qualified Technicians Only.

**CAUTION: DISCONNECT ELECTRICAL CURRENT BEFORE SERVICING**

Please Return This Sheet to its Envelope in the Product for Future Reference

Contents	Page
Error code explanation.....	1-2
Diagnostics .....	2
Error Code Chart.....	3
Tests.....	4-5
Wiring diagram.....	6-7

The electronic controls of the 3.0 Cu. Ft. horizontal axis washers have self diagnostics codes built in that cover most products failures.

### Model differences:

- Better models have a digital readout display
- Good models do not have a digital readout display

In the **Better Models** line, the failure codes will appear in the display as an E followed by two numbers, a number and a letter or two letters. The control will beep and the **Door Lock, Wash, Rinse, Final Spin and Control** indicator lights will flash. Example: **E14**. To stop the flashing and beeping, the customer may touch the **Pause Cancel** button. The error code remains stored in the control but once the problem is corrected, it does not effect the operation of the washer. If the failure is something that the customer can correct (such as the water faucets being turned off), the washer will operate normally the next time it is started.

In the **Good Models** line, the control signals the failure code by flashing the five indicator lights of **Door Lock, Wash, Rinse, Final Spin and Control** for the first number or letter after the E and the **Start** indicator light for the second number or letter after the E. When a failure occurs, the washer stops or pauses and the control beeps and flashes the five indicator lights to tell the customer that a failure has occurred. To stop the flashing and beeping, the customer may touch the **Pause Cancel** button. The error code remains stored in the control but once the problem is corrected, it does not effect the operation of the washer. If the failure is something that the customer can correct (such as the water faucets being turned off), the washer will operate normally the next time it is started.

To recall an error code,

- Wake the machine by pressing any button
- Wait 5 seconds
- Press and hold the **Start** and **Pause Cancel** buttons simultaneously
- All LEDs will go blank and after a few seconds the control will signal the stored code using audible beeps and blinking LEDs. The control will repeatedly signal the code, as long as the **Start and Pause Cancel** buttons are pressed.

A two-second pause between repeats affords you the ability to make accurate counts to identify the correct error codes.

Please Note the following..... on a small number of washers with serial number prefix XC4, if the previous procedure does not perform as specified, follow the option below:

- Follow all previous steps but instead of pressing **Start** and **Pause Cancel** buttons, press and hold **Options** and **Pause Cancel** buttons.

If the washer is a **Better Model**, the error code will appear in the display. Troubleshoot problem by using charts on the following pages.

If the washer is a **Good Model**, the five indicator lights of **Door Lock, Wash, Rinse, Final Spin and Control** will flash the number of times for the first digit of the code and the **Start** indicator light will flash the number of times for the second digit. Take separate counts of each indicator light, then repeat to confirm in order to be accurate in identifying the proper error code. The code is obtained by counting the number of times the lights flash. Example E24: The five indicator lights would flash twice indicating the 2 and the **START** indicator light will flash four times indicating the 4. The five indicator lights and the **START** indicator light start flashing at the same time.

The control will pause for 2 seconds, then repeat the code as long as the two buttons are pressed and held.

**Note: A letter appearing in the code stands for a number higher than nine:**

**A = 10 B = 11 C = 12 D = 13 E = 14 F = 15**

Example Code F1: the first digit would be 15 and the second digit would be 1. If this code would appear on a washer in the **Good** model line, the five indicator lights would blink fifteen times and the **START** indicator light would blink once. Troubleshoot problem by using charts on the following pages.

### Quick Check

If there is no error displayed and the washer momentarily starts then turns back off:

1. Listen for a relay closure inside the motor control shortly after the **START** key is pressed. If this happens, the motor control has power.
2. Check the 5 pin connector wiring between the console control and the motor control.

P/N 134542000

### Examples: Identifying Error Codes on non-digital display models:

The following LED Flashes and Beeps signal E41 (Error code 41) Door Open

	COUNT>>>>>>	1	2	3	4	5	6	7	8	9	A	B	C	D	E	F
1st Code Digit	5 Vertical LED Flashes	X	X	X	X											
2nd Code Digit	Start LED Flashes	X														

The following LED Flashes and Beeps signal E14 (Error code 14) Reed Switch

	COUNT>>>>>>	1	2	3	4	5	6	7	8	9	A	B	C	D	E	F
1st Code Digit	5 Vertical LED Flashes	X														
2nd Code Digit	Start LED Flashes	X	X	X	X											

The following LED Flashes and Beeps signal EF1 (Error code F1) Clogged Pump

		1	2	3	4	5	6	7	8	9	10	11	12	13	14	15
	COUNT>>>>>>	1	2	3	4	5	6	7	8	9	A	B	C	D	E	F
1st Code Digit	5 Vertical LED Flashes	X	X	X	X	X	X	X	X	X	X	X	X	X	X	X
2nd Code Digit	Start LED Flashes	X														

### Diagnostic Test:

The diagnostic test is performed by using the Program Knob. To START THE TEST:

- On non-digital display models, turn the **Program Knob** to start position, **Drain/Spin**.
- On digital display models, turn the **Program Knob** to start position, **Touch Up**. (**NOTE:** If the model has a timer dial that can be rotated 360°, turn the **Program Knob** to start position, **Drain/Spin**.)
- Press **Pause Cancel** to turn off LEDs.
- Within 5 seconds, press and hold the **Option** and **Pause Cancel** buttons until LEDs start sequentially chasing, then release buttons.

1. All the LEDs will sequentially light. Pressing a button below a light cluster will light all the LEDs in that cluster at one time to confirm functionality.
2. Turn the program knob (1) click clockwise from the start position. The hot water solenoid will activate and hot water should enter through the detergent compartment.
3. Turn the program knob (2) clicks from the start position. The bleach water solenoid will activate and cold water should enter through the bleach compartment.
4. Turn the program knob (3) clicks from the start position. The bleach and the wash water solenoids will activate and cold water should enter through the softener compartment.
5. Turn the program knob (4) clicks from the start position. The door lock solenoid will activate.
6. Turn the program knob (5) clicks from the start position. The door lock solenoid will deactivate and the loading door can be opened.
7. Turn the program knob (6) clicks from the start position. The washer will fill and tumble.
8. Turn the program knob (7) clicks from the start position. The washer will fill and spin (leakage test).
9. Turn the program knob (8) clicks from the start position. The drain pump and door lock solenoid will activate and the washer will operate in high spin. **SAFETY WARNING:** If power is removed during this test, the door can be opened. To prevent injury, DO NOT put your hands inside when the tub is rotating.
10. Turn the program knob (9) clicks from the start position. The control will signal the last error code.

### Exiting Diagnostic Mode

There are two options for exiting the Diagnostic Test mode and returning the washer to normal operation:

- a) Unplug the power cord, wait 5-8 seconds, then reconnect the power cord **OR**
- b) Turn the program knob clockwise 2 or 3 clicks after the Start Position. Press **Options** and **Pause Cancel** buttons together for a few seconds until wash cycle LEDs appear.

**If a situation arises where you cannot exit the Diagnostic mode as described above and the bank of 5 LED's on the right end remain ON regardless of Program Knob position, a combination of pushed buttons may have caused the control to enter a special factory test mode. Disconnect power to reset the control to return washer to normal operation is this occurs.**

### To clear latest stored error code:

Place the control into Diagnostic test Mode.

- Turn the program knob clockwise 9 clicks from the Start Position. The control will signal the last error code.
- Press and hold the **Options** and **Pause Cancel** buttons for 3 seconds. The code will be cleared.
- Exit Diagnostic Mode to return the washer to normal operation.

P/N 134542000

### Error code chart

Error code	Fault condition	Check
E11	Fill time too long.	Refer to test (1).
E13	Water leak in tub or air leak in air bell.	Refer to test (2).
E14	Reed switch.	Refer to test (3).
E21	Water not pumping out fast enough.	Refer to test (4).
E23	Drain pump relay on control board failed.	Replace control board.
E24	Drain pump relay on control board failed.	Replace control board.
E31	Better models. Pressure sensor not communicating with control board.	Refer to test (5).
E35	Better models. Pressure sensor indicates water overflow.	Refer to test (6).
E41	Control board thinks the door switch is open.	Refer to test (7).
E42	Door remains locked after cycle is completed.	Refer to test (8).
E43	Control board problem.	Replace the control board.
E44	Control board problem.	Replace the control board.
E45	Control board problem.	Replace the control board.
E46	Control board problem.	Replace the control board.
E47	Board thinks the door PTC circuit is open in spin.	Refer to test (9)
E48	Board thinks the door PTC circuit is closed.	Refer to test (9)
E52	Bad signal from tacho generator.	Refer to test (10)
E55	Motor overheating.	Refer to test (11)
E56	High motor current.	Refer to test (11)
E57	High current on inverter.	Refer to test (11)
E58	High current on motor phase.	Refer to test (11)
E59	No tacho signal for 3 seconds.	Refer to test (12)
E5A	High temperature on heat sink.	Replace the speed control board.
E5B	High temperature on heat sink.	Replace the speed control board.
E5C	High temperature on heat sink.	Replace the speed control board.
E5D	Communication problem.	Refer to test (13)
E5E	Communication problem.	Refer to test (13)
E5F	Communication problem.	Refer to test (13)
E67	Input voltage on microprocessor incorrect.	Replace the control board.
E75	Better models only. Water temperature sensor circuit.	Refer to test (14)
E76	Better model only. NTC temperature for the cold water valve over the limits.	Hot and cold water hoses switched.
E95	Communication error.	Replace the control board.
EB1	Incoming power frequency out of limits.	Refer to test (15)
EB2	Incoming line voltage above 130 VAC.	Check voltage at the outlet. If below 130 VAC, replace the control board.
EB3	Incoming line voltage below 90 VAC.	Check voltage at the outlet. If above 90 VAC, replace the control board.
EF1	Clogged drain pump.	Unclog the drain pump.
EF2	To much soap.	Advise customer to reduce the amount of soap they are using.

Test		
Test	Check	Correction
Test 1:	1. Is the incoming water flow normal?	Yes. Go to step (4). No. Go to step (2)
	2. Are the incoming water faucets turned	No. Turn water faucets on. Yes. Go to step (3).
	3. Is the incoming water pressure above (30) psi.	No. Have customer correct pressure problem. Yes. Check for kinked or blocked incoming water hoses, clean the incoming water screens. If problem still remains, replace the water inlet valve assembly.
	4. Does the fill water continue enter the washer?	Yes. Go to step (5). No. Go to step (6)
	5. Remove power from the washer. Did the water fill stop?	Yes. Go to step (6) No. Replace the inlet valve assembly.
	6. Good models, check the pressure switch.	Pressure switch checks good. Go to step (8). Pressure switch checks bad. Replace pressure switch.
	7. Better models, replace the pressure sensor.	If this did not correct the problem, go to step 8.
	8. Replace the control board.	
Test 2:	1. Is the washer leaking water?	Yes. Correct water leak. No. Go to step (2)
	2. Is there an air leak in the air bell system?	Yes. Correct the air leak problem. No. Go to step (3-4)
	3. Good models, check the pressure switch.	Defective. Replace the pressure switch. Good. Go to step (5)
	4. Better models, replace the pressure sensor.	If this did not correct the problem, go to step 5.
	5. Replace the control board.	
Test 3:	1. Is the dispenser drawer closed?	No. Close the drawer. Yes. Go to step (2).
	2. Remove the drawer and check the magnet.	Magnet missing or defective. Replace the magnet. Magnet good. Go to step (3).
	3. Open the console and check the reed switch.	Defective. Replace the reed switch. Good. Replace the control board.
Test 4:	1. Check the drain hose for restrictions.	Restriction. Correct problem. No restriction. Go to step (2).
	2. Start the washer and check for 120 VAC at the drain pump.	Zero. Replace the control board. 120 VAC. Remove the pump and check for blockage. If blocked, remove the restriction, if not, replace the pump.
Test 5:	Inspect the wiring between the pressure sensor and the control board.	Defective wiring. Correct wiring. Good wiring. Replace the pressure sensor. If this does not correct the problem, replace the control board.

Test		
Test	Check	Correction
Test 6:	1. Is the water level above 4.5 inches?	Yes. Go to step (2). No. Go to step (4).
	2. Does water enter the washer continuously.	Yes. Go to step (3). No. Replace the control board.
	3. Remove power from washer. Does the water stop coming in?	No. Replace water valve assembly. Yes. Check wiring to valve assembly for shorts. If wiring is good, replace the control board.
	4. Replace the pressure sensor switch. Did this correct the problem?	Yes. Problem solved. No. Replace the control board.
Test 7:	1. Is the loading door closed?	No. Close the door. Yes. Go the step (2).
	2. Disconnect the plug from J2 on the control board and check for continuity between the pins in the plug.	Open. Check the door strike. If good, replace the door switch assembly. Closed. Replace the control board.
Test 8:	1. Remove power from the washer. Wait one minute. Can you open the door?	Yes. Replace the control board. No. Replace the door switch assembly. Note: You may have to break the door strike to do this.
Test 9:	1. Remove the door lock assembly and measure the resistance of the PTC.	Shorted or open. Defective door lock assembly. Reads around 1500 Ohms. Defective control board.
Test 10:	1. Disconnect the plug from the drive motor and measure the resistance pins 4 & 5 in the motor.	If the reading is between 105 & 130 Ohms, replace the speed control board. If the meter reads other than between 105 & 130 Ohms, replace the motor.
Test 11:	1. Remove the belt from the motor and spin the motor pulley. Does the motor spin free?	No. Replace the motor. Yes. Go to step (3)
	2. Spin the tub pulley. Does the tub spin free?	No. Check the tub bearings. Yes. Go to step (3)
	3. Disconnect the plug from the motor and measure the resistance of the windings (pin 1 to pin 2, pin 1 to pin 3, pin 2 to pin 3). All readings should be between 4 and 6 Ohms.	If the readings are correct, replace the speed control board. If the readings are incorrect, replace the motor.
Test 12:	1. Remove the belt from the motor and spin the motor pulley. Does the motor spin free?	No. Replace the motor. Yes. Go to step (3)
	2. Spin the tub pulley. Does the tub spin free?	No. Check the tub bearings. Yes. Go to step (3)
	3. Disconnect the plug from the drive motor and measure the resistance between pins 4 & 5 in the motor.	If the meter reads other than between 105 & 130 Ohms, replace the motor. If the reading is between 105 & 130 Ohms, Go to step (4)
	4. Disconnect the plug from the motor and measure the resistance of the windings (pin 1 to pin 2, pin 1 to pin 3, pin 2 to pin 3). All readings should be between 4 and 6 Ohms.	If the readings are correct, replace the speed control board. If the readings are incorrect, replace the motor.
Test 13:	1. Communication problem. Check the wiring between the control board and the speed control board.	Wiring bad. Correct wiring problem. Wiring good. Replace the control board. If the problem is not corrected, replace the speed control board.
Test 14:	1. Check the resistance of the NTC. Is it around 50K ohms?	No. Replace the water inlet valve assembly Yes. Replace the control board.
Test 15:	1. Have the power company check the frequency of the incoming power. If correct, replace the control board.	

**⚠ WARNING** TO REDUCE THE RISK OF ELECTRICAL SHOCK DISCONNECT THIS APPLIANCE FROM THE POWER SUPPLY BEFORE ATTEMPTING ANY USER MAINTENANCE. TURNING THE CONTROLS TO THE OFF POSITION DOES NOT DISCONNECT THIS APPLIANCE FROM THE POWER SUPPLY.

**⚠ AVERTISSEMENT** POUR RÉDUIRE LE RISQUE DE CHOC ÉLECTRIQUE, DÉBRANCHER CET APPAREIL DE L'ALIMENTATION AVANT DE PROCÉDER À L'ENTRETIEN. EN TOURNANT LES COMMANDES À LA POSITION ARRÊT, L'ON NE COUPE PAS L'ALIMENTATION ÉLECTRIQUE DE L'APPAREIL.

**⚠ ADVERTENCIA** PARA REDUCIR EL RIESGO DE CHOQUE ELÉCTRICO, DESENCHUFE ESTE APARATO DE LA ALIMENTACIÓN ELÉCTRICA ANTES DE EFECTUAR EL MANTENIMIENTO. AL GIRAR LOS CONTROLES A LA POSICIÓN OFF (APAGADO) NO SE CORTA LA ALIMENTACIÓN ELÉCTRICA AL ARTEFACTO.

COMPONENT RESISTANCE TABLE		
ELECTRICAL COMPONENT	RESISTANCE Ω @ 77°F (25°C)	
DOOR LOCK SOLENOID	1325 ±10%	
PUMP MOTOR	12.0 ±7%	
DISPENSER VALVE SOLENOIDS	800 ±7%	
MOTOR	M1 TO M2	5.3 ±7%
	M2 TO M3	5.3 ±7%
	M1 TO M3	5.3 ±7%
	M5 TO M4	118 ±7%

TABLEAU DE RÉSIDENCE DES COMPOSANTS		
COMPOSANT ÉLECTRIQUE	RÉSISTANCE Ω @ 77°F (25°C)	
SOLENOÏDE DU LOQUET DE PORTE	1325 ±10%	
MOTEUR DE POMPE	12.0 ±7%	
SOLENOÏDE DU ROBINET DISTRIBUTEUR	800 ±7%	
MOTEUR	M1 VERS M2	5.3 ±7%
	M2 VERS M3	5.3 ±7%
	M1 VERS M3	5.3 ±7%
	M5 VERS M4	118 ±7%

TABLA DE RESISTENCIA DE LOS COMPONENTES		
COMPONENTE ELÉCTRICO	RESISTENCIA Ω @ 77°F (25°C)	
SOLENOÏDE DE CIERRE DE LA PUERTA	1325 ±10%	
BOMBA DE MOTOR	12.0 ±7%	
SOLENOÏDE DE LA VÁLVULA DEL DISTRIBUIDOR	800 ±7%	
MOTOR	M1 A M2	5.3 ±7%
	M2 A M3	5.3 ±7%
	M1 A M3	5.3 ±7%
	M5 A M4	118 ±7%

SELECT MODELS \ MODÈLS DE SELECTEUR \ MODELOS DE SELECTOR

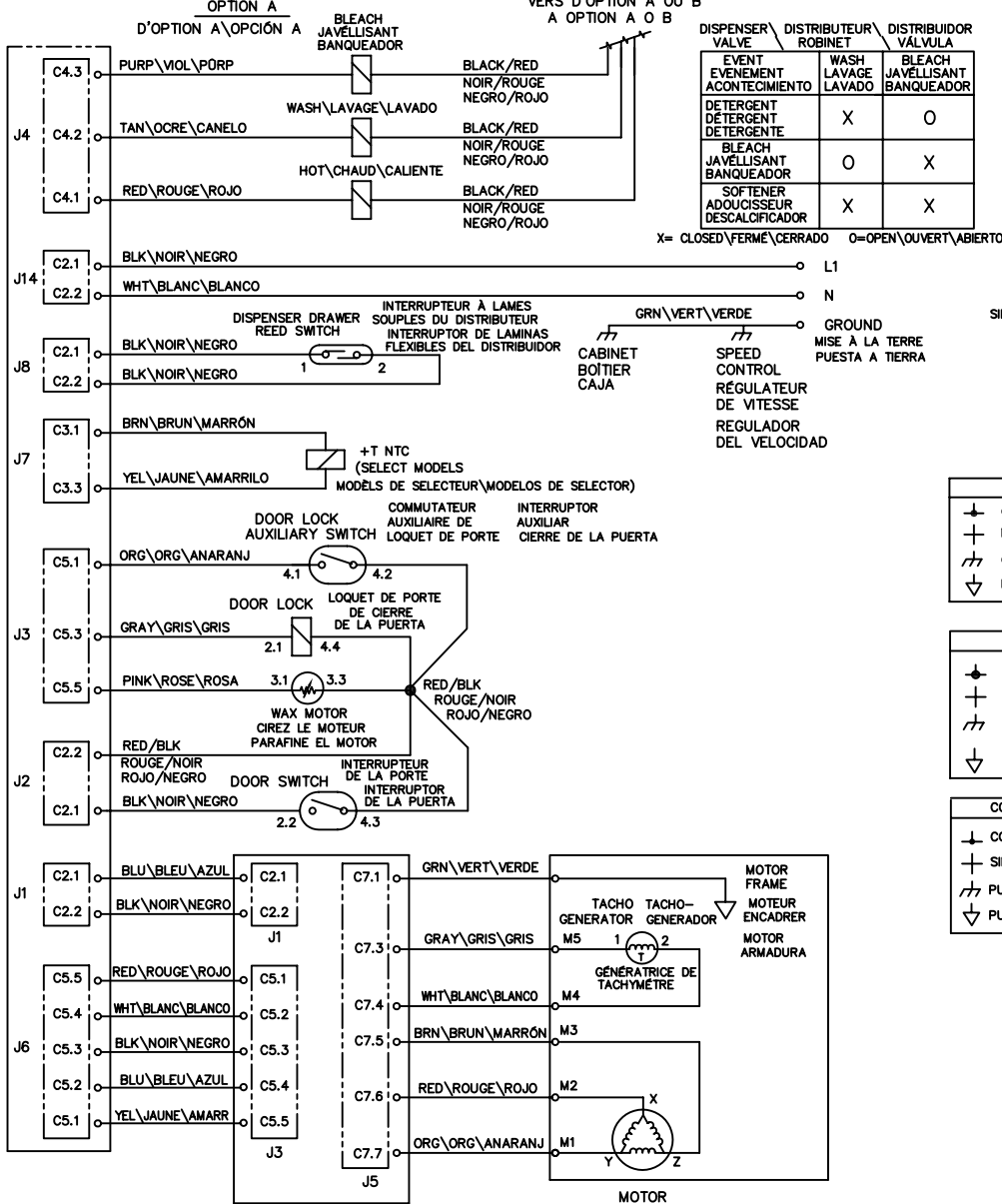
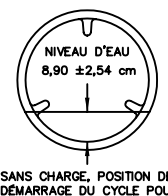
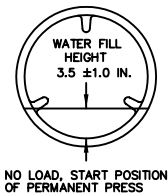
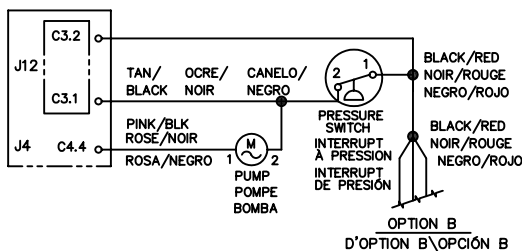
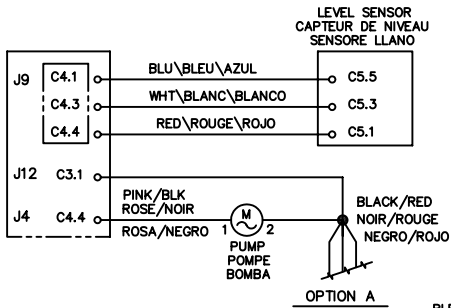

WIRING CODES	
⬇	CONNECTION
+	NO CONNECTION
⌋	CABINET GROUND
⌋	LOCAL GROUND

CODES DE CÂBLAGE	
⬇	CONNEXION
+	AUCUNE CONNEXION
⌋	MISE À LA TERRE DE CARROSSERIE
⌋	MISE À LA TERRE DE LOCAL

CODIGOS DEL CABLEADO	
⬇	CONEXIÓN
+	SIN CONEXIÓN
⌋	PUESTA A TIERRA DE CAJA
⌋	PUESTA A TIERRA DE LOCAL

MOTOR CONTROL BOARD  
PANNEAU DE COMMANDE MOTEUR  
PANEL DE CONTROL MOTOR

MOTOR  
MOTEUR

WIRING DIAGRAM PART NO.  
SCHEMA DE CÂBLAGE NO DE PIÈCE  
DIAGRAMA DE CONEXIONES NO DE PIEZA

134542000